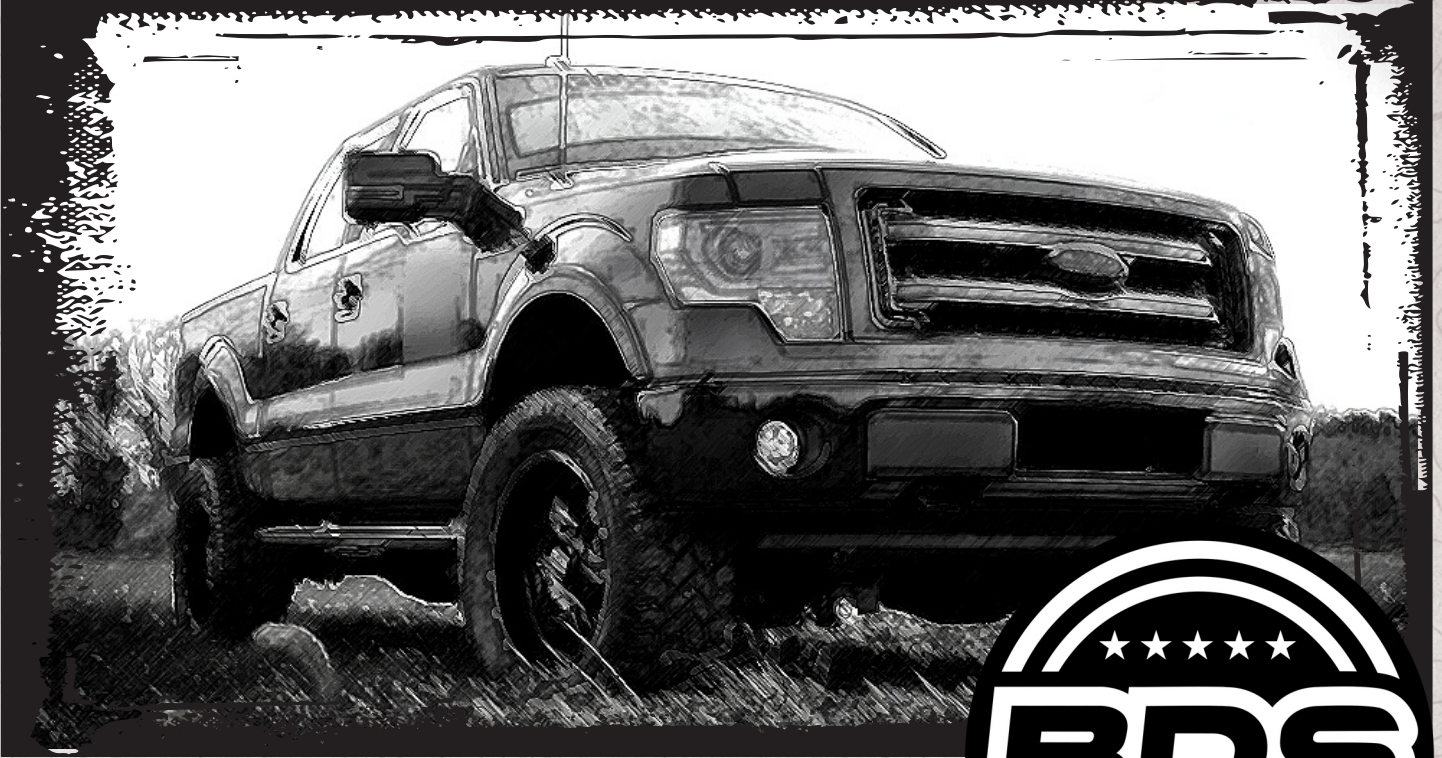


# INSTALLATION GUIDE



Part#: 023624



**HARDCORE LIMITED LIFETIME WARRANTY**

## 4" & 6" Suspension System

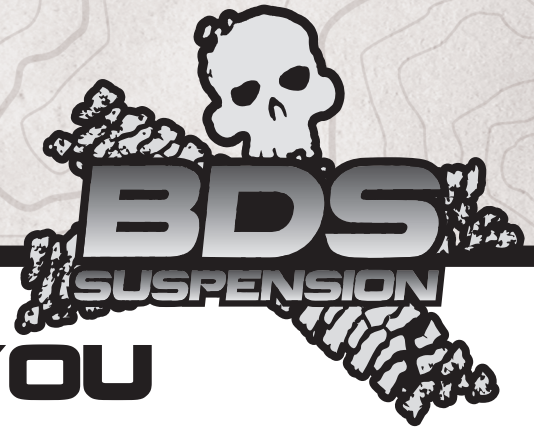
**Ford F150 2WD | 2009-2014**

Rev. 121725

491 W. Garfield Ave., Coldwater, MI 49036 • Phone: 517-279-2135

Web/live chat: [www.bds-suspension.com](http://www.bds-suspension.com) • E-mail: [tech@bds-suspension.com](mailto:tech@bds-suspension.com)

# Read And Understand All Instructions And Warnings Prior To Installation Of System And Operation Of Vehicle.



## THANK YOU

Your truck is about to be fitted with the best suspension system on the market today. That means you will be driving the baddest looking truck in the neighborhood, and you'll have the warranty to ensure that it stays that way for years to come. Thank you for choosing BDS Suspension!

### BEFORE YOU START

BDS Suspension Co. recommends this system be installed by a professional technician. In addition to these instructions, professional knowledge of disassembly/ reassembly procedures and post installation checks must be known.

### FOR YOUR SAFETY

Certain BDS Suspension products are intended to improve off-road performance. Modifying your vehicle for off-road use may result in the vehicle handling differently than a factory equipped vehicle. Extreme care must be used to prevent loss of control or vehicle rollover. Failure to drive your modified vehicle safely may result in serious injury or death. BDS Suspension Co. does not recommend the combined use of suspension lifts, body lifts, or other lifting devices. You should never operate your modified vehicle under the influence of alcohol or drugs. Always drive your modified vehicle at reduced speeds to ensure your ability to control your vehicle under all driving conditions. Always wear your seat belt.

### BEFORE INSTALLATION

Special literature required: OE Service Manual for model/year of vehicle. Refer to manual for proper disassembly/reassembly procedures of OE and related components.

Adhere to recommendations when replacement fasteners, retainers and keepers are called out in the OE manual.

Larger rim and tire combinations may increase leverage on suspension, steering, and related components. When selecting combinations larger than OE, consider the additional stress you could be inducing on the OE and related components.

Post suspension system vehicles may experience drive line vibrations. Angles may require tuning, slider on shaft may require replacement, shafts may need to be lengthened or trued, and U-joints may need to be replaced.

Secure and properly block vehicle prior to installation of BDS Suspension components. Always wear safety glasses when using power tools.

If installation is to be performed without a hoist, BDS Suspension Co. recommends rear alterations first.

Due to payload options and initial ride height variances, the amount of lift is a base figure. Final ride height dimensions may vary in accordance to original vehicle attitude. Always measure the attitude prior to beginning installation.

### BEFORE YOU DRIVE

Check all fasteners for proper torque. Check to ensure for adequate clearance between all rotating, mobile, fixed, and heated members. Verify clearance between exhaust and brake lines, fuel lines, fuel tank, floor boards and wiring harness. Check steering gear for clearance. Test and inspect brake system.



Visit [560plus.com](http://560plus.com) for more information.

### TRACTION CONTROL

In an effort to reduce the risk of rollover crashes the National Highway Traffic Safety Administration (NHTSA) established the Federal Motor Vehicle Safety Standard (FMVSS) No. 126 requiring all new passenger vehicles under 10,000 lbs GVWR include an electronic stability control (ESC) system as standard equipment. Effective August 2012 this law requires after-market products to be compliant with these same standards.



### TIRES AND WHEELS

#### FITMENT GUIDE

(Trimming may be required)

- 35 x 12.5 with 18 x 9 and 4.5 in. Backspace
- 37 x 12.5 with 18 x 9 and 5 in. Backspace
- 37 x 12.5 with 20 x 9 and 5.5 in. Backspace



Perform steering sweep to ensure front brake hoses have adequate slack and do not contact any rotating, mobile or heated members. Inspect rear brake hoses at full extension for adequate slack. Failure to perform hose check/ replacement may result in component failure. Longer replacement hoses, if needed can be purchased from a local parts supplier.

Perform head light check and adjustment.

Re-torque all fasteners after 500 miles. Always inspect fasteners and components during routine servicing.

# CONTENTS OF YOUR KIT

## 023405/023425 Box Kit (4" kit only)

Part #	Qty	Description
02429	1	Rear 4" Block- Drv
02430	1	Rear 4" Block- Pass
02079B	1	E-Brake Bracket
963181212QB	4	9/16x3-1/8x12-1/2 Square U-bolt
01716	1	Brake Line Bracket
W96S-B	8	9/16 SAE flat washer
N96FH-B	8	9/16 Fine High Nut
02427	1	Strut Spacer
02427	1	Strut SPacer (023425 only)
02428	1	Strut Spacer - Pass (023405 only)
400408-10	1	Vent Hose Ext (023425 only)
769	1	Bolt Pack - Strut Spacer
	6	7/16"-14 nylock nut
	6	3/8" USS flat washer
605	1	Bolt Pack E-brake bracket
	2	7/16"-14 x 1 1/4" bolt
	2	7/16"-14 prevailing torque nut
	4	7/16" SAE washer
768	1	Bolt Pack- Rear brake line bracket
	2	1/4"-20 x 3/4" bolt
	2	1/4"-20 nylock nut
	4	1/4" USS flat washer

## 013529 Rear Box kit (6" Only)

1716	1	Offset Brake Line Drop Bracket
2085	2	5" Offset Rear Block
02079B	1	E-Brake Bracket - black
2086	2	Lower Spring Plate
120400FCP	2	1/2 x 4 Pin w/Nut
02087B	2	Upper Spring Plate
774	1	Bolt Pack - Rear Block Kit
	2	1/2"-20 x 3-1/2" bolt flat SHCS
	2	1/2"-20 nut
	2	7/16"-14 x 1-1/4" bolt
	4	7/16" SAE washer
	2	7/16"-14 Prevailing torque nut
	1	1/4"-20 prevailing torque nut
	1	1/4" USS washer
963181212QB	4	9/16x3-1/8x12-1/2 Square U-bolt
W96S-B	8	9/16 SAE Washer
N96FH-B	8	9/16 Fine High Nut

## 023625 Box Kit

Part #	Qty	Description
02065	1	Steering Knuckle - Drv

## 023626

Part #	Qty	Description
02067	1	Steering Knuckle - Pass

## 023624 Box Kit

02318B	2	Crossmember Brace
02068B	1	Front Crossmember
02083B	1	Rear Crossmember
02070B	2	Sway Bar Drop - black
02002	2	Eccentric Cam Bolt
02074	2	M18 x 170 931-10.9 HCS Cam Bolt
02001	8	Eccentric Cam
N18MPT	4	M18 x 2.5 Prevailing Torque Nut
01715	2	Brake Line Relocation Bracket
773	1	Bolt Pack - Main
	2	18mm-2.50 x 150mm bolt
	4	3/4" SAE washer
	2	18mm-2.50 prevailing torque nut
	2	1/4"-20 prevailing torque nut
	4	1/4" USS flat washer
	2	6mm-1.00 x 18mm bolt
	4	1/2"-13 x 1-1/4" button head bolt
	4	1/2" SAE Washer
	4	3/8"-16 x 1-1/4" bolt
	8	3/8" SAE washer
	4	3/8"-16 prevailing torque nut
407	1	Bolt Pack - Sway Bar Drop
	8	3/8" USS washer
	4	7/16"-14 x 1-1/4" bolt
	4	7/16"-14 prevailing torque nut

## 98163 Box kit (2009-13 6" Only)

P01484	2	Strut Parts Pack
5398	2	6" Strut
N12MF	2	12mm Flanged Nut

## 023605 Box Kit (2014 6" kit only)

02725	2	Strut Spacer
400-408-10	1	Vent Hose Extension
769	1	Bolt Pack - Strut Spacer
	6	7/16"-14 nylock nut
	6	3/8" USS flat washer

## TECH TIPS

### TROUBLESHOOTING INFORMATION FOR YOUR VEHICLE

1. 18" or larger diameter wheels required. Stock 17" & 18" wheels cannot be reinstalled. Stock 20" wheels can be used with up to a 305/60-20 tires.
2. E-brake bracket required for factory powersteps (123018)
3. Will not fit HD models (7 lug).
4. For a level to tail low appearance use #023416 with Kit#1504H. Block kits replace factory 1-1/4" block.

## INSTALLATION INSTRUCTIONS

### SPECIAL TOOLS

1. Strut/Spring compressor
2. Metric/Standard Socket Wrench Set
3. Cut-off Tool

### INSTALLATION INSTRUCTIONS

#### FRONT INSTALLATION

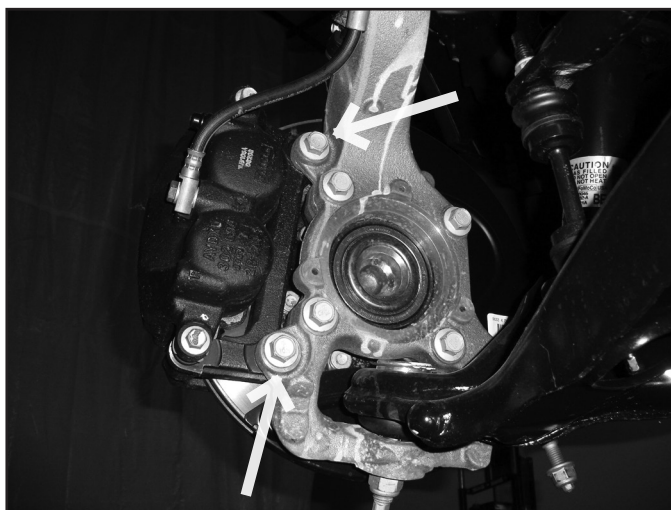
1. Park the vehicle on a clean, flat surface and block the rear wheels for safety.
2. Measure from the center of the wheel up to the bottom edge of the wheel opening and record below:

LF \_\_\_\_\_ RF \_\_\_\_\_

LR \_\_\_\_\_ RR \_\_\_\_\_

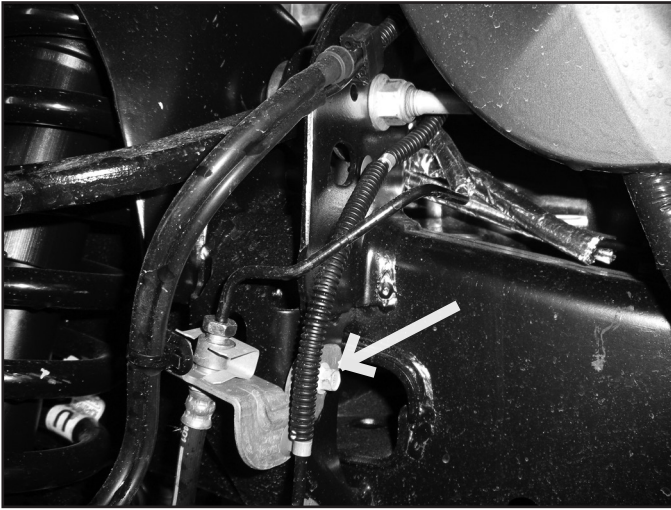
3. Raise the front of the vehicle and support with jack stands at each frame rail behind the lower control arms.
4. Remove the front wheels.
5. Remove the brake caliper anchor bracket bolts and remove the caliper from the knuckle (Fig 1). Hang the caliper out of the way. Do not let the caliper hang by the brake hoses.

**FIGURE 1**



6. Remove the brake rotor and set aside.
7. Disconnect the ABS and hub vacuum lines from the retaining clips. Disconnect the brakeline bracket from the frame rail. Disconnect the ABS line from the inner fenderwell, and disconnect the clip(Fig 2a / b).

**FIGURE 2A**



**FIGURE 2B**



8. Disconnect the tie rod ends from the steering knuckles (Fig 3).
9. Remove and retain the mounting nuts. Strike the steering knuckle near the tie rod end to dislodge the end. Take care not to strike the tie rod end.

**FIGURE 3**



10. Remove the upper and lower ball joint nuts and reinstall a few turns.
11. Strike the knuckle near the upper and lower ball joints to dislodge the joints from the knuckle.
12. Remove the upper ball joint and lower ball joint nuts and remove the knuckle from the vehicle. Save ball joint nuts.
13. Disconnect the sway bar links from the sway bar (Fig 4). Retain hardware. The sway bar links do not need to be removed from the lower control arms.

**FIGURE 4 - 2009-13 MODEL SHOWN**



14. Remove the four sway bar mounting nuts and remove the sway bar from the vehicle (Fig 5). Retain hardware
15. Remove the strut-to-lower control arm mounting bolt on 2009-13 models. 2014 models: remove the lower strut bar pin bolts. Save hardware

**FIGURE 5**



16. Remove the lower control arm mounting bolts (Fig 6) and remove the lower control arms from the vehicle. Save hardware.

**FIGURE 6**



17. Mark the struts to distinguish between driver's and passenger's. In addition, mark the relationship between the coil and the lower strut mounting hole and finally the top plate and the rubber coil seat.
18. Remove the three strut assembly mounting nuts at the frame (Fig 7) and remove the struts from the vehicle. Do not loosen the middle strut nut.

**FIGURE 7**



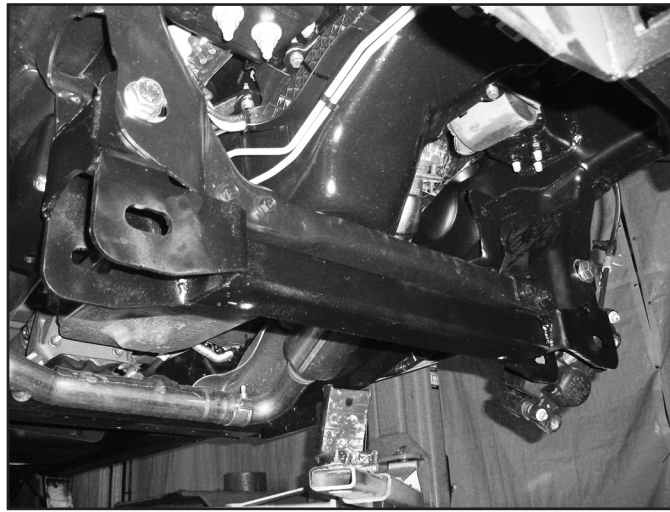
19. The factory rear control arm pockets must also be trimmed to clear the new rear crossmember. Measure down 1-3/4" from the center of the factory control arm slot and make a horizontal cut line. The cut will stop where the vertical offset in the factory mount begins. (Fig 8)

**FIGURE 8**



20. Install the new rear crossmember (02083) in the rear lower control arm frame pockets and fasten with new 18mm x 150mm bolts and washers (BP 773). Do not put nuts on at this time. Run bolts from front to rear. Leave hardware loose. (Fig 9). Note: The offset portion of the crossmember ends go toward the front of the vehicle and the factory rear crossmember remains in place.

**FIGURE 9**



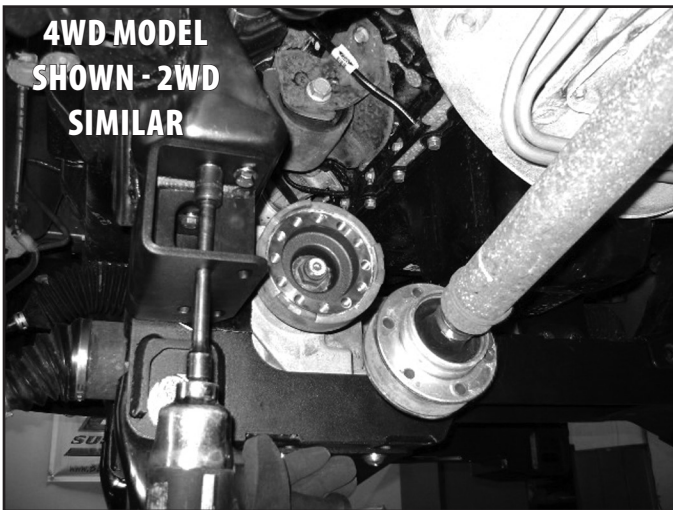
21. Install the front crossmember in the front lower control arm pockets and fasten with the original lower control arm hardware (Fig 10). Run bolts from front to rear. Leave hardware loose.

**FIGURE 10**

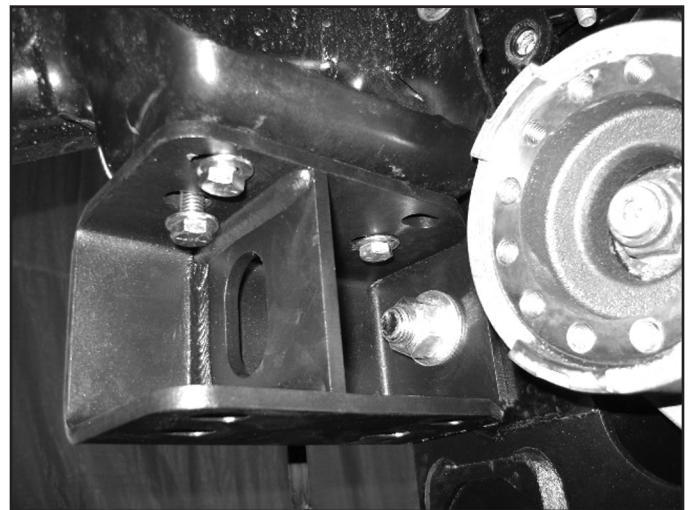


22. Install the lower control arms in the new crossmembers and fasten with the provided 18mm cam bolts, cam washers and 18mm nuts. Run the front bolts from front to rear and leave loose. Run the rear bolts from rear to front. The main body of the cam will be 'up' in the cam slot.
23. Install the provided crossmember supports to the front and rear crossmembers with  $\frac{1}{2}$ " x 1- $\frac{1}{4}$ " button head bolts and  $\frac{1}{2}$ " SAE washers (BP 773) into the threaded holes in the crossmembers. Leave hardware loose.
24. Install the sway bar drop brackets with new  $\frac{3}{8}$ " x 1- $\frac{1}{4}$ " bolts, washers and nuts. Run hardware from bottom - up, snug but do not tighten at this time. Attach the crossmember 18mm nut with  $\frac{3}{4}$ " USS washer (BP 773). Note: Use a ratchet extension through the lower slots to access the hardware (Fig 11a, 11b)

**FIG 11A**



**FIG 11B**



25. With the lower control arms installed, go back and torque the four crossmember mounting bolts to 222 ft-lbs. Ensure that the front crossmember is centered in the vehicle. Apply Loctite to the threads and torque the crossmember support bolts to 60 ft-lbs. Tighten sway bar drop hardware to 35 ft-lbs.

**4" & 6" STRUT SPACER KITS SKIP TO STEPS 32-33, 2009-13 6" REPLACEMENT STRUT KITS: USE STEPS 26-31**

26. (6" kit only 2009-13 models) Place the strut assembly into a high quality spring compressor. ⚠ Only use a high quality wall mounted spring compressor! (Fig 12)

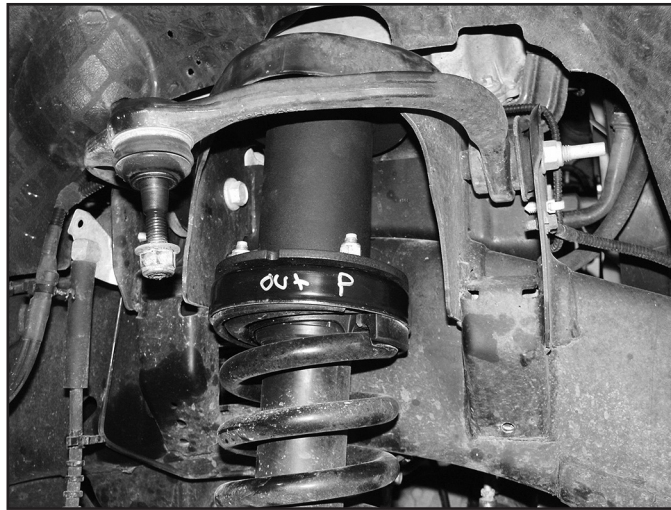
**FIGURE 12**



27. (6" kit only 2009-13 models) Compress the coil following spring compressor instructions and remove the strut nut.
28. (6" kit only 2009-13 models) Remove the top cap and upper spring isolator.
29. (6" kit only 2009-13 models) Turn the new strut rod counterclockwise to release the rod and allow it to extend. Install the new lower coil seat and bump stop onto the replacement strut.

30. (6" kit only 2009-13 models) Align marks on coil to the upper mount and also with the lower mounting hole. Install the new strut in the coil spring and factory top cap. Fasten the strut rod with the new provided 12mm flange nut. Torque strut rod nut to 40 ft-lbs.
31. (6" kit only 2009-13 models) Install the strut assemblies in the appropriate sides on the vehicle with OE hardware, leave hardware loose at this time. Skip ahead to step 36.
32. (6" strut spacer kits, 2014 models) The same strut spacer is used on both sides. Place the 02725 strut spacer on each strut and attach with the factory hardware. Tighten to 40 ft-lbs.
33. (4" strut spacer kits, 2014 models) The same strut spacer is used on both sides. Place the 02427 strut spacer on each strut and attach with the factory hardware. The strut spacers are located in the rear box kit. Tighten to 40 ft-lbs.
34. (4" & 6" strut spacer kits, 2009-13 models) Place the top spacer (02427 or 02725 = Driver side, 02428 or 02726 = Passenger side) on the correct side strut. Attach with the factory hardware and tighten to 40 ft-lbs.
35. (4" & 6" strut spacer kits, 2009-14 models) Install the strut and spacer assembly into the vehicle. Attach to upper mount with new 7/16" nuts and washers (bolt pack #769). Leave hardware loose at this time. (Fig 13).

**FIGURE 13**



#### **4" AND 6" KITS**

36. Remove the four hub bolts from the knuckle and remove the hub from the knuckle (Fig 14). Inspect mounting surface of the hub assembly and clean any dirt or corrosion off as necessary.

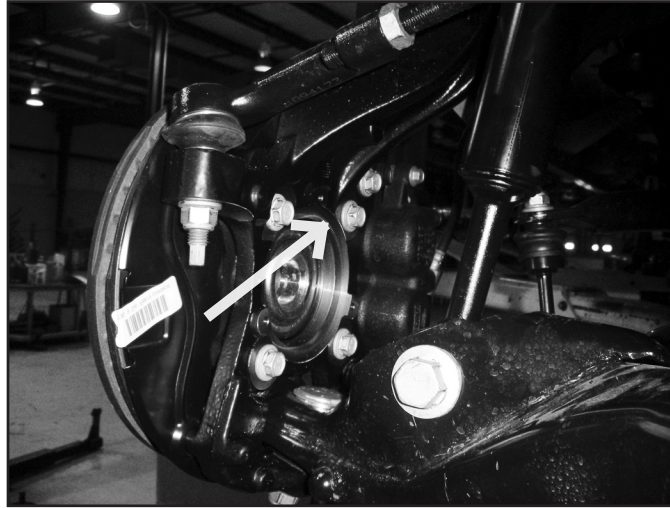
**FIGURE 14 - 4WD SHOWN, 2WD SIMILAR**



37. Install the hub into the corresponding new BDS knuckle (drv- 02065, pass- 02067) and fasten with the OE bolts. The ABS wire will be located at the 'top' of the hub. Use Loctite on the bolt threads and torque to 148 ft-lbs.
38. Remove the factory dust shields from the original knuckles and install them on the new knuckles with the factory 6mm bolts. Tighten bolts securely (about 5-7 ft-lbs). Route the ABS cable between the dust shield and the knuckle.

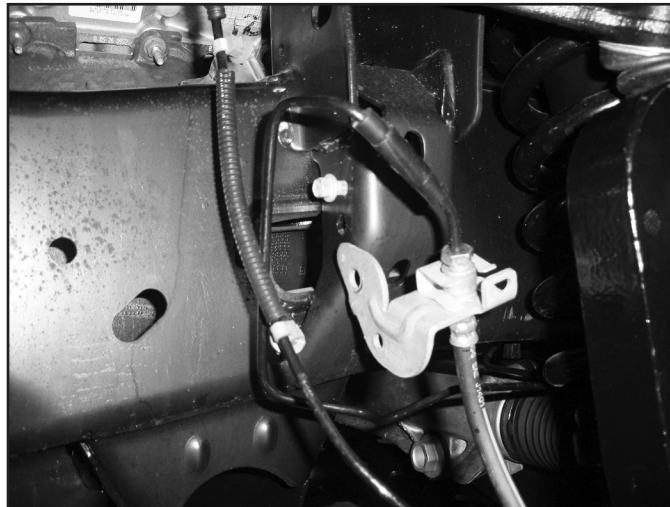
39. Install the new knuckle assembly on the lower control arm ball joint and loosely fasten with the original nut. Leave hardware loose.
40. Attach the upper control arm to the knuckle with the original nut. Torque the upper ball joint to 85 ft-lbs and the lower ball joint to 111 ft-lbs.
41. Torque the upper strut frame mount nuts to 35 ft-lbs. The lower bolt will be tightened later with the weight of the vehicle on the suspension.
42. Install the brake rotor and caliper to the knuckle with OE bolts. Torque to 148 ft-lbs. (Fig 15)

**FIGURE 15**



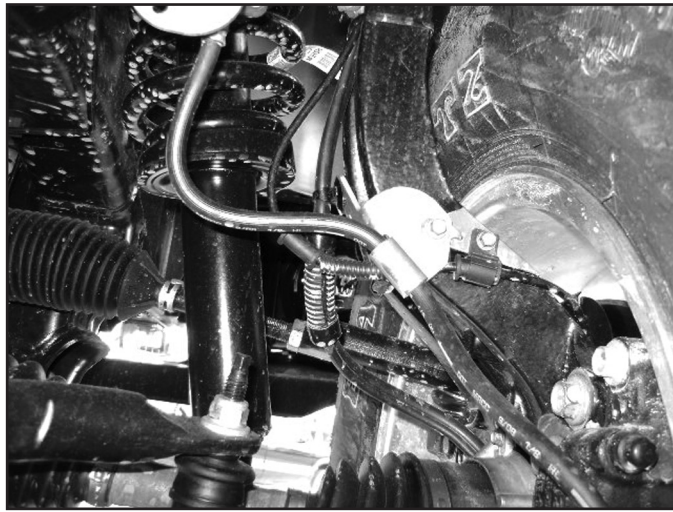
43. Install the brake line relocation brackets at the frame (Fig 16). Attach with OE hardware to frame, attach brakeline retaining clip with 1/4" nut and washer to the relocation bracket. Tighten to 15 ft-lbs.

**FIGURE 16**



44. Attach the ABS line to the connector at the inner fender and the vacuum line to the hub. Route the lines similar to the factory setup down to the side of the knuckle. Attach the ABS wire with the factory 6mm bolt to the side of the knuckle. Attach the brakeline with a new 6mm x 18mm bolt with 1/4" washer to the side of the knuckle (BP# 773), the brakeline locating tab will go into the unthreaded hole. (Fig 17).

**FIGURE 17**



45. Install the sway bar to the new sway bar drop brackets (Fig 18) with 7/16" x 1-1/4" bolts, nuts and 7/16" SAE washers (BP 407). Attach the sway bar to the sway bar end links with the original hardware. Torque the 7/16" hardware to 45 ft-lbs. Torque sway bar link nut to 45 ft-lbs.

**FIGURE 18**



46. Install tie rod ends to the knuckles from top-down. Torque to 111 ft-lbs.
47. Install the wheels and lower the vehicle to the ground.
48. Bounce the front of the vehicle to settle the suspension. Torque the lower strut mount bolt to 350 ft-lbs. Center the lower control arm cams and torque to 150 ft-lbs. Adjust the toe-in before driving it to an alignment shop.
49. Check all hardware for proper torque.

## **REAR INSTALLATION**

50. Block the front wheels and raise the rear of the vehicle. Place jack stands under the frame rails ahead of the spring hangers.
51. Remove the wheels.
52. The parking brake cable must be relocated. To disconnect the cable from the frame first pull down on the cable and clamp it off with vise grips near the middle of the frame (Fig 19). This will gain slack to disconnect the driver's side rear cable from the main (passenger's side) cable.
53. Remove the driver's side parking brake cable from the junction bracket (Fig 20).

**FIGURE 19**

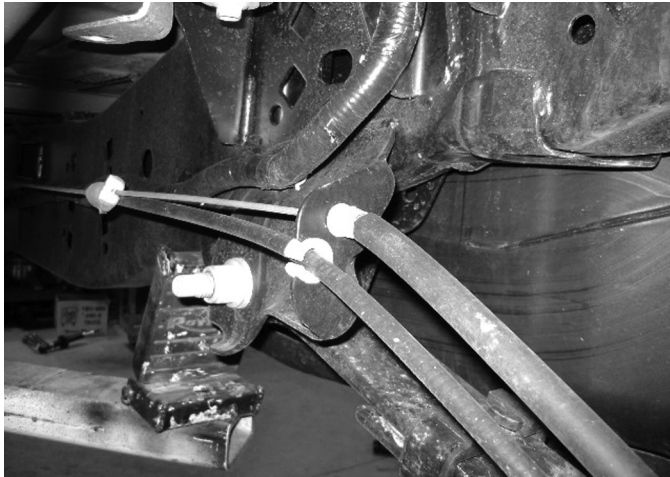


**FIGURE 20**

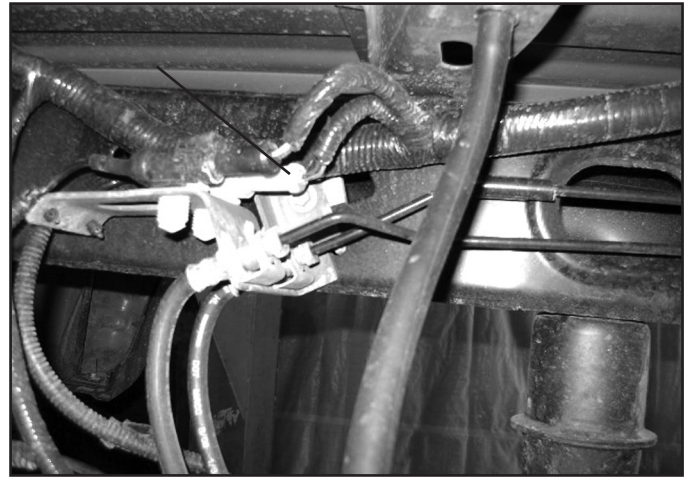


- 54. Compress the retaining tabs and remove the driver's side cable from the spring hanger (Fig 21). It will be relocated and reconnected later.
- 55. Disconnect the rear brake line from the frame. (Fig 22)

**FIGURE 21**



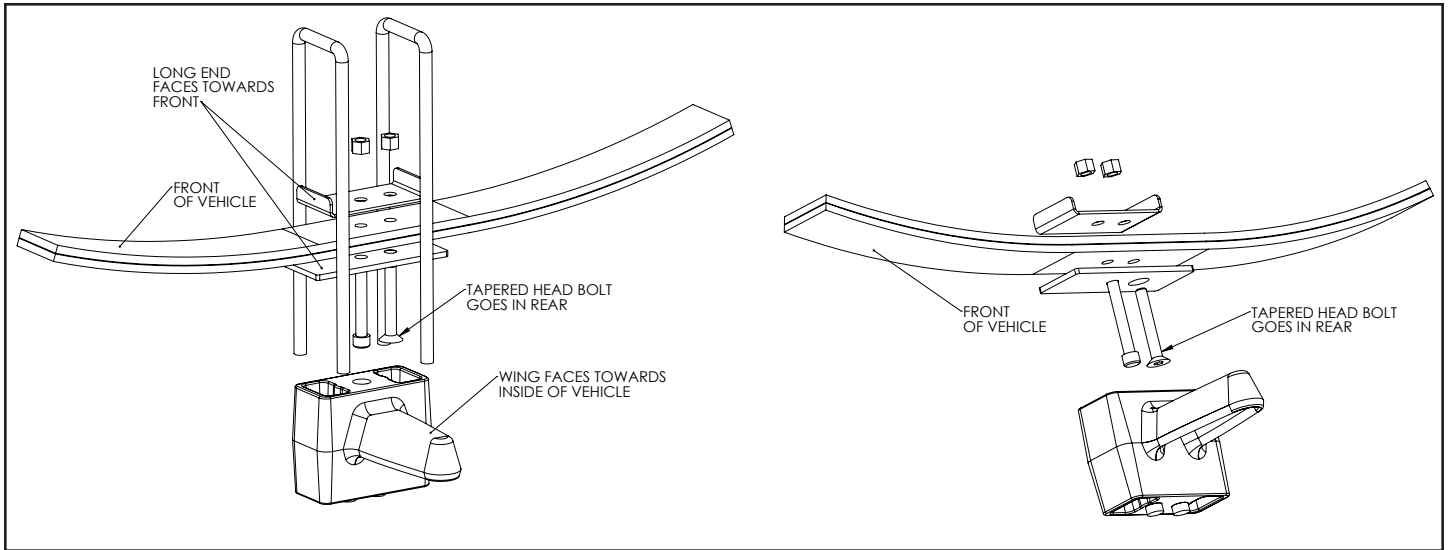
**FIGURE 22**



- 56. Support the rear axle with a hydraulic jack. Remove the OE shocks. Retain mounting hardware.
- 57. Note: Perform the rear installation on one side at a time.
- 58. Remove the passenger's side u-bolts.
- 59. Lower the axle and remove the OE lift block, it will not be reused.
- 60. 5" rear block kit use steps 61-65. 4" rear block kit use steps 66-67.
- 61. Using C-clamps, clamp the leaf spring pack together on each side of the center pins. Remove the center pins and discard.

62. Place the plate on the bottom of the leaf pack and secure with new center pin in the 'forward' hole and flat head allen bolt through the 'rear' hole. Install new u-bolt reatining plate on top, it will be offset 'forward'. Tighten to 35 ft-lbs. (Fig 23, 24, 25)

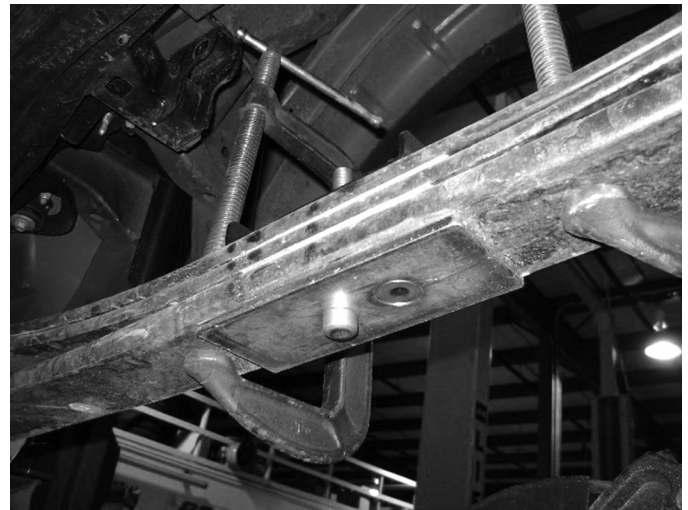
**FIGURE 23**



**FIG 24**

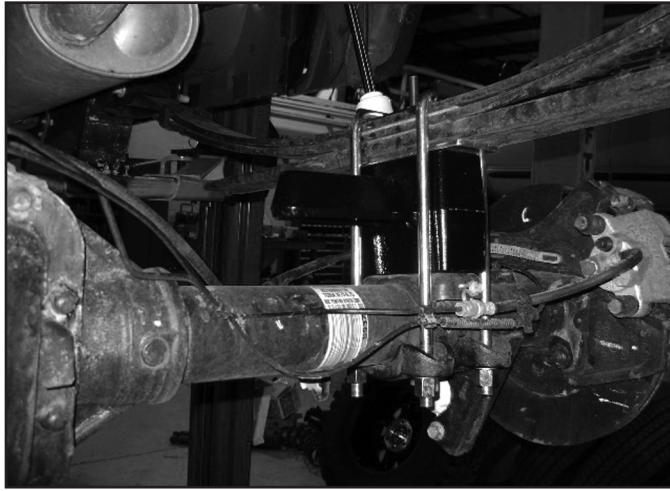


**FIG 25**



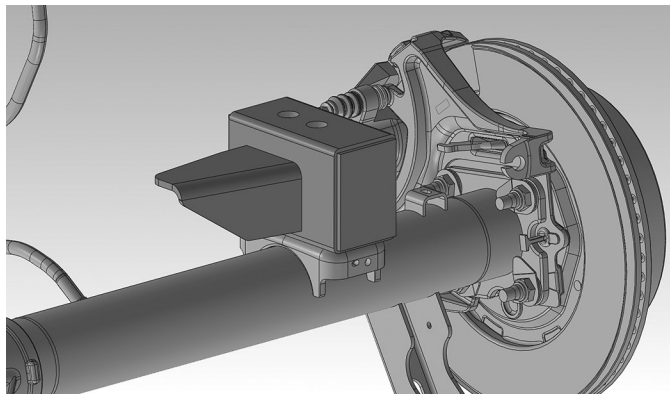
63. Install the new provided lift block so that the bump stop wing goes toward the inside of the vehicle. The block will use the both of the lower center pin holes. The upper only uses 1 hole which will shift the axle slightly forward.
64. Raise the axle/block to the spring while aligning the center pin. Fasten the spring/block assembly with the provided u-bolts, high nuts and washers. Snug u-bolts, they will be torque with the weight of the vehicle on the springs. (Fig 26)

**FIGURE 26**



65. Repeat installation procedure on the driver's side of the vehicle. Skip ahead to step # 68.
66. Install rear block (02429 - DRV side, 02430 - Pass side). The block is designed to offset the axle forward slightly. The bump stop wing will be centered under the bump stop on the frame with the vertical gusset facing towards the front of the vehicle. Align the center pins and raise axle. (Fig 27)

**FIGURE 27**



67. Attach u-bolts with the factory lower u-bolt plate. Snug u-bolts, they will be torqued to specification when the vehicle is on the ground.
68. Install the provided parking brake relocation bracket to the driver's side front spring hanger using 7/16" bolts, washers, and nuts. (Fig 29)
69. Reconnect the parking brake cable at the junction. When reconnected, remove the clamp to allow the cable to return to its normal tension. Attach the parking brake cable through the relocation bracket through the slot in the bottom (Fig 28)

**FIGURE 28**



70. Install the provided brake line relocation bracket to the driver's side frame rail with the OE brake line bracket bolt (Fig 29). Torque to 15 ft-lbs.

**FIGURE 29**



71. Attach the brake line to the relocation bracket with a 1/4" nut and 1/4" USS washer (BP #774). It may be necessary to rotate the OE brakeline clip bracket to have the lines face 'down' for adequate slack. Torque to 15 ft-lbs.
72. Install the provided new BDS shocks with the OE hardware. Torque to 60 ft-lbs.
73. Check all lines/wires for proper slack.
74. Install the wheels and lower the vehicle to the ground.
75. Bounce the rear of the vehicle to settle the suspension.
76. Torque the u-bolts to 100-120 ft-lbs.
77. Check all hardware for proper torque
78. Check hardware after 500 miles.
79. A complete front end alignment is necessary.
80. Adjust headlights.



## **WE WANT TO SEE YOUR RIDE!**

Grab photos of your BDS-equipped truck in action and send them in for a chance to be featured. Send it in to our Bad Ass Rides customer gallery at [bds-suspension.com/bar](http://bds-suspension.com/bar) and post them on the BDS Fan Page on Facebook at [facebook.com/BDSSuspensions](https://facebook.com/BDSSuspensions). Don't forget about your BDS swag! BDS offers t-shirts, hoodies, decals and more available on the BDS website or through your local BDS distributor.

---

## **TIME TO HAVE SOME FUN**

**Thank you for choosing BDS Suspension.**

For questions, technical support and warranty issues relating to this BDS Suspension product, please contact your distributor/installer before contacting BDS Suspension directly.