

INSTALLATION GUIDE



Part#: 123303



HARDCORE LIMITED LIFETIME WARRANTY

Ride Height Sensor Bracket Relocation Kit

Ford F250/350/450 - 4WD | 2023-2026

Rev. 010726

491 W. Garfield Ave., Coldwater, MI 49036 • Phone: 517-279-2135

Web: www.bds-suspension.com • E-mail: tech-bds@ridefox.com

Read And Understand All Instructions And Warnings Prior To Installation Of System And Operation Of Vehicle.



THANK YOU

Your truck is about to be fitted with the best suspension system on the market today. That means you will be driving the baddest looking truck in the neighborhood, and you'll have the warranty to ensure that it stays that way for years to come.

Thank you for choosing BDS Suspension!

BEFORE YOU START

BDS Suspension Co. recommends this system be installed by a professional technician. In addition to these instructions, professional knowledge of disassembly/ reassembly procedures and post installation checks must be known.

FOR YOUR SAFETY

Certain BDS Suspension products are intended to improve off-road performance. Modifying your vehicle for off-road use may result in the vehicle handling differently than a factory equipped vehicle. Extreme care must be used to prevent loss of control or vehicle rollover. Failure to drive your modified vehicle safely may result in serious injury or death. BDS Suspension Co. does not recommend the combined use of suspension lifts, body lifts, or other lifting devices. You should never operate your modified vehicle under the influence of alcohol or drugs. Always drive your modified vehicle at reduced speeds to ensure your ability to control your vehicle under all driving conditions. Always wear your seat belt.

BEFORE INSTALLATION

- Special literature required: OE Service Manual for model/year of vehicle. Refer to manual for proper disassembly/reassembly procedures of OE and related components.
- Adhere to recommendations when replacement fasteners, retainers and keepers are called out in the OE manual.
- Larger rim and tire combinations may increase leverage on suspension, steering, and related components. When selecting combinations larger than OE, consider the additional stress you could be inducing on the OE and related components.
- Post suspension system vehicles may experience drive line vibrations. Angles may require tuning, slider on shaft may require replacement, shafts may need to be lengthened or trued, and U-joints may need to be replaced.
- Secure and properly block vehicle prior to installation of BDS Suspension components. Always wear safety glasses when using power tools.
- If installation is to be performed without a hoist, BDS Suspension Co. recommends rear alterations first.
- Due to payload options and initial ride height variances, the amount of lift is a base figure. Final ride height dimensions may vary in accordance to original vehicle attitude. Always measure the attitude prior to beginning installation.



Visit 560plus.com for more information.

TIRES AND WHEELS

N/A



BEFORE YOU DRIVE

Check all fasteners for proper torque. Check to ensure for adequate clearance between all rotating, mobile, fixed, and heated members. Verify clearance between exhaust and brake lines, fuel lines, fuel tank, floor boards and wiring harness. Check steering gear for clearance. Test and inspect brake system.

Perform steering sweep to ensure front brake hoses have adequate slack and do not contact any rotating, mobile or heated members. Inspect rear brake hoses at full extension for adequate slack. Failure to perform hose check/ replacement may result in component failure. Longer replacement hoses, if needed can be purchased from a local parts supplier.

Perform head light check and adjustment.

Re-torque all fasteners after 500 miles. Always inspect fasteners and components during routine servicing.

CONTENTS OF YOUR KIT

Box Kit		
Part #	Qty	Description
05539	2	Sensor Lever Arm
05605	1	Sensor Mounting Bracket- Drv
05606	1	Sensor Mounting Bracket- Pass
05544	1	OE Radius Arm Linkage Mount- Drv
05545	1	OE Radius Arm Linkage Mount- Pass
05546	1	BDS Radius Arm & 4-Link Linkage Lower Mount- Driver
05547	1	BDS Radius Arm & 4-Link Linkage Lower Mount- Passenger
05548	2	BDS Radius Arm & 4-Link Linkage Upper Mount
BP1079	1	Bolt Pack
	2	5/16"-18 Nylock Hex Nut, Clear Zinc
	2	10mm Ball Stud, 5/16"-18, 0.54"
	2	1/4"-20 x 1/2" Bolt
	2	1/4"-20 Serrated Edge Nut
	2	1/4"-20 x 3/4" Bolt
	2	1/4"-20 Nylock Nut
	4	1/4" SAE Washer
	2	5/16"-18 x 3/4" Bolt
	2	5/16"-18 Nylock Nut
	4	5/16" SAE Washer
	4	1/4"-20 x 3/4" Button Head Bolt- Stainless Steel Black Oxide
	4	1/4"-20 Nylock Nut- Stainless Steel Black Oxide
099000	4	Zip Tie

INSTALLATION INSTRUCTIONS

SPECIAL TOOLS

T20 Torx Bit

INSTRUCTIONS

1. Working one side at a time, locate the frame mounted ride height sensor (**Fig. 1**)

FIGURE 1

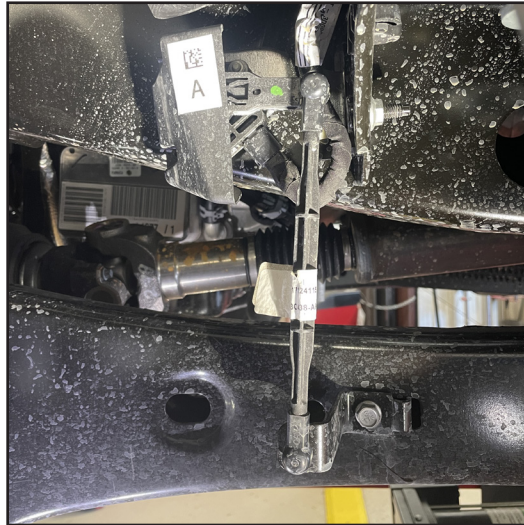

2. Unplug the wire harness from the sensor using a clip tool, remove the harness retention clip from the OE sensor bracket.
3. Disconnect the linkage rod from the radius arm mounting bracket using an 8mm wrench or socket.
4. Using a 13mm wrench, loosen and remove the nut holding the OE sensor bracket to the frame. The sensor assembly can now be removed from the vehicle.
5. Using a small pry tool, carefully remove the linkage rod from the sensor lever arm.
6. Using a T20 Torx bit, remove the plastic shield from the sensor bracket.
7. Using an 8mm wrench, remove the two bolts holding the sensor to the bracket.
8. Using a large flat blade screwdriver or spreading pliers, spread the two tabs and pull out on the pivot ball to remove the OE sensor lever arm. (**Fig. 2**)

FIGURE 2



9. Insert the new lever arm into the Sensor.
10. Attach the new ball stud to the lever arm and secure with 5/16" nylock nut.

11. Attach the linkage rod to the ball stud. A vise is helpful for this process, but not required.
12. Attach the sensor to the new sensor bracket using the oe hardware. The sensor brackets are side specific, so be sure to use the bracket with a similar profile to the oe bracket.

CALIBRATION INSTRUCTION

Refer to the below table to determine the correct points of alignment for the OE height sensor and the bolt stop. Note that the table displays the vehicle model type, Diesel, Diesel Tremor, Gas and Gas Tremor. Find the appropriate model for your application then the kit height and type, 1" Spacer, 2" Spacer, 3" Radius Arm, 4/5" Radius Arm, 6/7" Radius Arm, 4/5" 4-Link or 6/7" 4-Link.

EXAMPLE



	Diesel	Diesel Tremor	Gas	Gas Tremor
1" Spacer	1-D1	2-DT2	2-GT2	2-GT2
2" Spacer	1-D1	1-DT1	1-GT1	1-GT1
3" Radius Arm	1-D1	1-DT1	1-GT1	1-GT1
4/5" Radius Arm	1-D1	1-DT1	2-GT2	2-GT2
6/7" Radius Arm	1-D1	1-DT1	1-GT1	1-GT1
4/5" 4-Link	1-D1	1-DT1	N/A	N/A
6/7" 4-Link	1-D1	1-DT1	N/A	N/A





RIDE HEIGHT SENSOR CALIBRATION CHART

	Diesel	Diesel Tremor	Gas	Gas Tremor
1" Spacer	1-D1	2-DT2	2-GT2	2-GT2
2" Spacer	1-D1	1-DT1	1-GT1	1-GT1
3" Radius Arm	1-D1	1-DT1	1-GT1	1-GT1
4/5" Radius Arm	1-D1	1-DT1	2-GT2	2-GT2
6/7" Radius Arm	1-D1	1-DT1	1-GT1	1-GT1
4/5" 4-Link	1-D1	1-DT1	N/A	N/A
6/7" 4-Link	1-D1	1-DT1	N/A	N/A

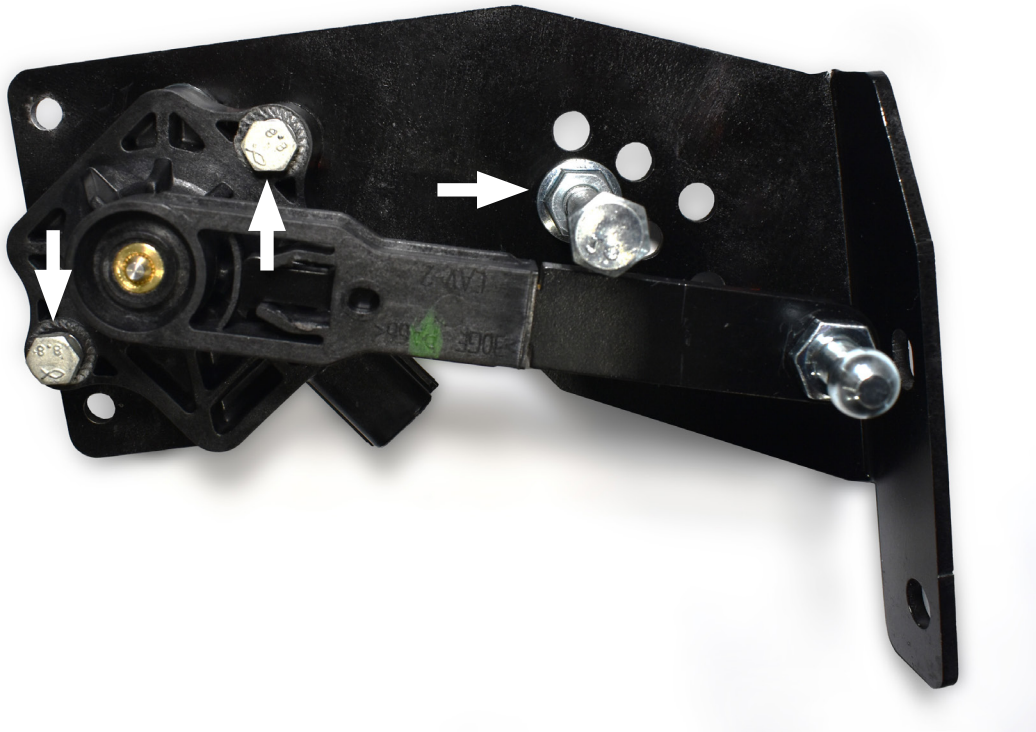

13. Determine from the chart the 2 correct mounting holes for the ride height sensor. Mount sensor. Use the calibration chart to determine the correct mounting hole for the calibration bolt. Install the ride height sensor calibration bolt according to the fitment chart. NOTE: Sensor arm should be below the calibration bolt. **Fig. 3**

FIGURE 3



14. Re-Install the OE sensor shield using the factory hardware.(Fig. 4)

FIGURE 4



15. To ensure proper clearance to the new linkage components, the wire harness on each side must be slightly relocated. On the passenger's side, unclip the plastic shielded wire harness from the frame and secure inboard using zip ties. **(Fig. 5)**
16. On the driver's side, clip the first zip tie securing the wire harness to the body mount bracket and remove the christmas tree clip securing the wire harness to the frame. Using zipties, secure the wire harness back. It may be most effective to secure a zip tie to the smaller harness near the ground screw. **(Fig. 6)**

FIGURE 5

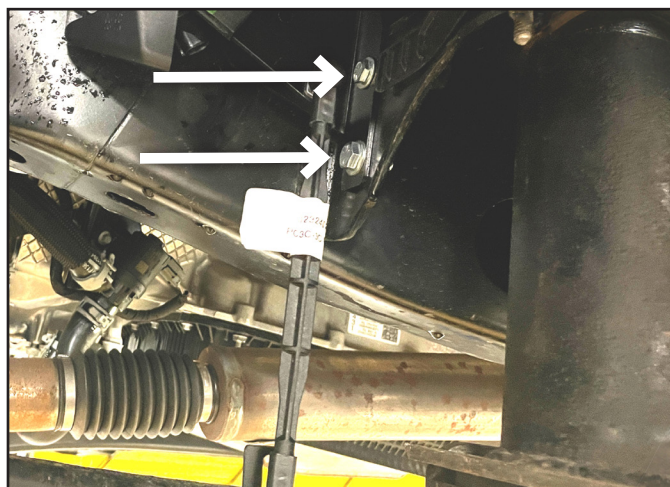

FIGURE 6



17. Install the sensor bracket assembly on the frame using the 5/16"-18x3/4" and 1/4"-20x3/4" bolts, nylock nuts and washers. **(Fig. 7)**

FIGURE 7



18. Check clearance to wire harness through full range of motion.

OE RADIUS ARM

19. Remove the OE radius arm linkage bracket by removing the bolt using a 13mm wrench. **(Fig. 8)**

FIGURE 8



20. A new radius arm side linkage bracket is included. Brackets are side specific. Attach the new bracket to the radius arm using oe hardware. (Fig. 9)

FIGURE 9



BDS RADIUS ARM

21. The brackets included to attach the ride height sensor to the linkage clamp to the top radius arm tube and are located by the vertical tube.
22. Install the two clamp halves as shown below and secure using the provided 1/4" black stainless hardware, driver's side radius arm shown. (Fig. 10)

FIGURE 10



4-LINK

23. Use the brackets included to attach the ride height sensor to the linkage clamp to the top 4-link tube and are located by the tab on the upper control arm. (Note the tab is pointing towards the rear with the slot vertical).

FIGURE 11 (DRIVER SIDE SHOWN)

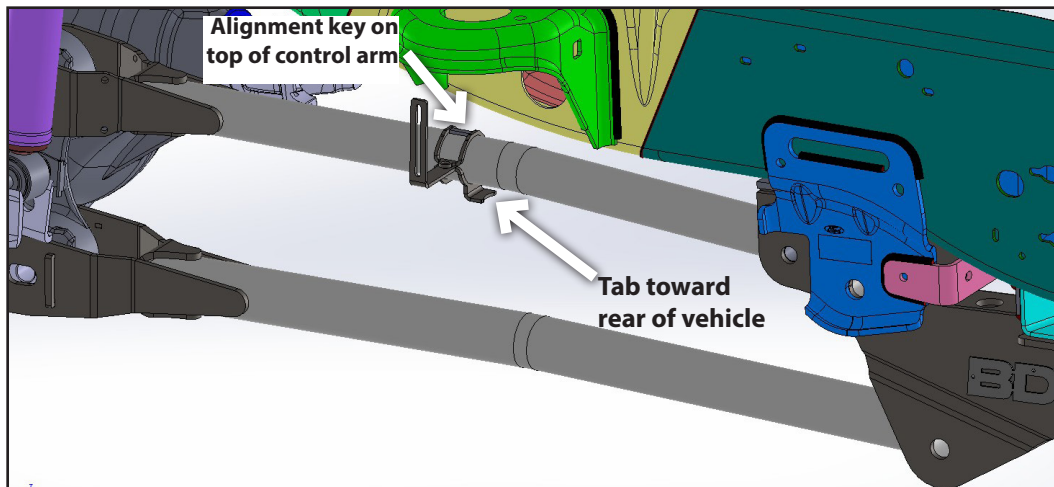

24. Install the two clamp halves as shown below and secure using the provided 1/4" black stainless hardware, driver's side radius arm shown. (Fig. 12). The slotted face on the sensor mount must be vertical (perpendicular to the ground).

FIGURE 12 (DRIVER SIDE SHOWN)

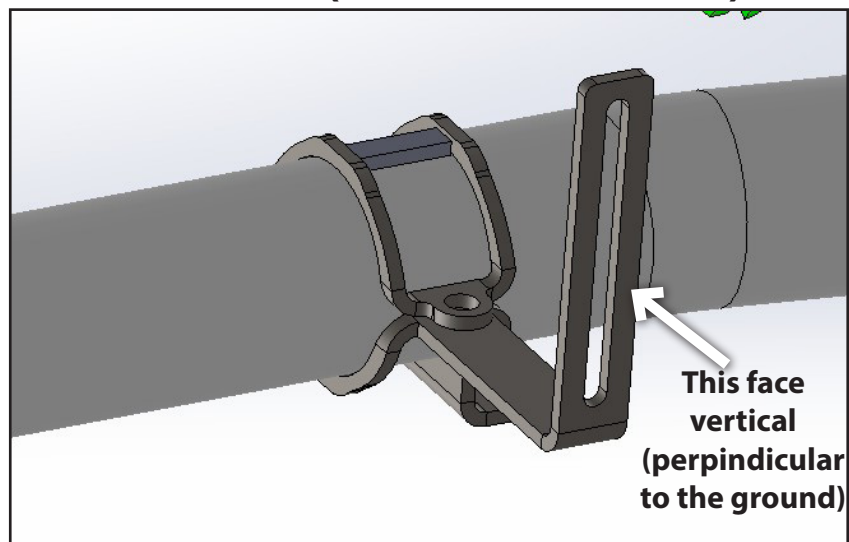

FINAL STEPS

25. When all other new suspension components are installed and the suspension is on the ground and settled, the linkage can be attached to the radius arm or 4-link mount.
26. Secure the lower end of the linkage rod using the OE nut. The lower mount is slotted to account for slight variations in ride height and various lift heights.
27. Remove the calibration bolt and flange lock nut.
28. Insert wire harness retention clip into slot on bracket.
29. Reinstall wire harness plug into sensor.
30. Fully cycle vehicle suspension to ensure sensor can handle full range or motion of Shock.

FIGURE 13



WE WANT TO SEE YOUR RIDE!

Grab photos of your BDS-equipped truck in action and send them in for a chance to be featured. Send it in to our Bad Ass Rides customer gallery at bds-suspension.com/bar and post them on the BDS Fan Page on Facebook at facebook.com/BDSSuspensions. Don't forget about your BDS swag! BDS offers t-shirts, hoodies, decals and more available on the BDS website or through your local BDS distributor.

TIME TO HAVE SOME FUN

Thank you for choosing BDS Suspension.

For questions, technical support and warranty issues relating to this BDS Suspension product, please contact your distributor/installer before contacting BDS Suspension directly.