

INSTALLATION GUIDE

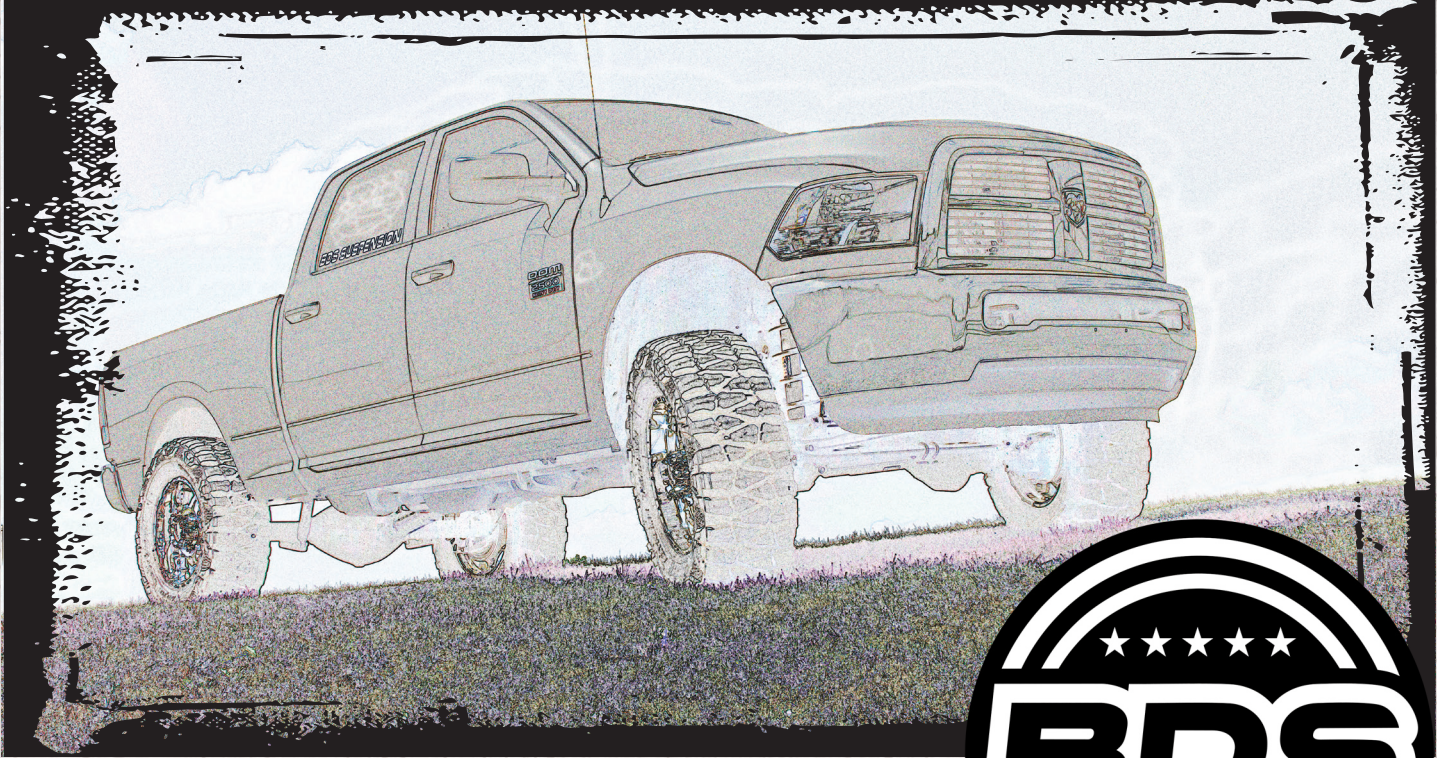

Part#: 122811

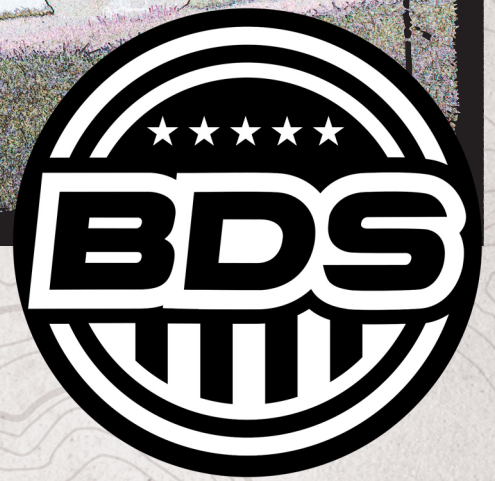

HARDCORE LIMITED LIFETIME WARRANTY

Transfer Case Indexing Kit

Dodge Ram 2500/3500 | 2009-2012

Rev. 090325

491 W. Garfield Ave., Coldwater, MI 49036 • Phone: 517-279-2135

Web/live chat: www.bds-suspension.com • E-mail: tech-bds@ridefox.com

Read And Understand All Instructions And Warnings Prior To Installation Of System And Operation Of Vehicle.



THANK YOU

Your truck is about to be fitted with the best suspension system on the market today. That means you will be driving the baddest looking truck in the neighborhood, and you'll have the warranty to ensure that it stays that way for years to come. Thank you for choosing BDS Suspension!

BEFORE YOU START

BDS Suspension Co. recommends this system be installed by a professional technician. In addition to these instructions, professional knowledge of disassembly/ reassembly procedures and post installation checks must be known.

FOR YOUR SAFETY

Certain BDS Suspension products are intended to improve off-road performance. Modifying your vehicle for off-road use may result in the vehicle handling differently than a factory equipped vehicle. Extreme care must be used to prevent loss of control or vehicle rollover. Failure to drive your modified vehicle safely may result in serious injury or death. BDS Suspension Co. does not recommend the combined use of suspension lifts, body lifts, or other lifting devices. You should never operate your modified vehicle under the influence of alcohol or drugs. Always drive your modified vehicle at reduced speeds to ensure your ability to control your vehicle under all driving conditions. Always wear your seat belt.

BEFORE INSTALLATION

- Special literature required: OE Service Manual for model/year of vehicle. Refer to manual for proper disassembly/reassembly procedures of OE and related components.
- Adhere to recommendations when replacement fasteners, retainers and keepers are called out in the OE manual.
- Larger rim and tire combinations may increase leverage on suspension, steering, and related components. When selecting combinations larger than OE, consider the additional stress you could be inducing on the OE and related components.
- Post suspension system vehicles may experience drive line vibrations. Angles may require tuning, slider on shaft may require replacement, shafts may need to be lengthened or trued, and U-joints may need to be replaced.
- Secure and properly block vehicle prior to installation of BDS Suspension components. Always wear safety glasses when using power tools.
- If installation is to be performed without a hoist, BDS Suspension Co. recommends rear alterations first.
- Due to payload options and initial ride height variances, the amount of lift is a base figure. Final ride height dimensions may vary in accordance to original vehicle attitude. Always measure the attitude prior to beginning installation.



Visit 560plus.com for more information.

BEFORE YOU DRIVE

Check all fasteners for proper torque. Check to ensure for adequate clearance between all rotating, mobile, fixed, and heated members. Verify clearance between exhaust and brake lines, fuel lines, fuel tank, floor boards and wiring harness. Check steering gear for clearance. Test and inspect brake system.

Perform steering sweep to ensure front brake hoses have adequate slack and do not contact any rotating, mobile or heated members. Inspect rear brake hoses at full extension for adequate slack. Failure to perform hose check/ replacement may result in component failure. Longer replacement hoses, if needed can be purchased from a local parts supplier.

Perform head light check and adjustment.

Re-torque all fasteners after 500 miles. Always inspect fasteners and components during routine servicing.

CONTENTS OF YOUR KIT

Transfer Case Indexing Ring

Part #	Qty	Description
02296	1	Front driveshaft spacer
932	1	Bolt pack - front driveshaft spacer
A238	1	T-case indexing ring w/ studs pressed in
932	1	Bolt pack - t case indexing ring
950	1	Bolt Pack - t case metrics

TECH TIPS

TROUBLESHOOTING INFORMATION FOR YOUR VEHICLE

1. BDS Suspension recommends upgrading the transmission output shaft on vehicles with larger tires that will see heavy loads from other upgrades such as gearing, or performance tunes especially in high payload, heavy towing, or competition pulling applications.
2. Kit is designed to be installed with lifts of 6-8 inches. If the kit is being installed with a kit other than a BDS Long Travel Kit, the front driveshaft spacer may or may not need to be installed. It is the installers responsibility to ensure there is adequate slip engagement in the driveshaft through wheel travel.
3. **DO NOT USE FILL PORT FOR FLUID LEVEL ON AN INDEXED TRANSFER CASE. THE FILL PORT WILL BE LOWER THAN OE FILL LEVEL HEIGHT:** If any maintenance requiring fluid change or refill has or is being done, before reinstalling transfer case check fluid levels on bench and fill transfer case with manufacturer recommended volume of fluid.
4. Due to variances in OE drivetrains, it may not be necessary to install the transfer case indexing ring. The indexing ring lowers the front output by approximately 2.5". Measure the clearance from the driveshaft flange down to the top of the crossmember. On most applications this will measure about 3" and can use the indexing ring. If the measurement is close to 2.5" some minor grinding may be necessary on the crossmember for driveshaft clearance once the indexing ring has been installed. If it is less than 2.5", do not install the transfer case indexing ring due to the interference with the crossmember in the indexed position.



INSTALLATION INSTRUCTIONS

INSTALLATION INSTRUCTIONS

1. Park vehicle on clean flat and level surface.
2. Block the wheels for safety.
3. Leave the transmission in neutral for the installation of the transfer case indexing ring.
4. Remove the rear driveshaft from the vehicle. Mark the driveshaft at the axle so that it can be reinstalled in the same manner it was removed. It will take 2 people to hold the weight of the driveshaft (it's heavy), remove carrier bearing hardware if equipped. (Fig 1a, 1b)

SPECIAL TOOLS

Transmission jack highly recommended

FIGURE 1A



FIGURE 1B

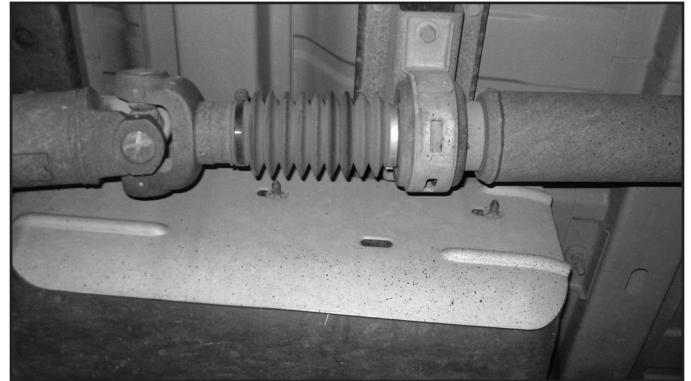

5. Support the transmission with an appropriate type of transmission jack. Take extra care not to damage the transmission pan or any lines around the pan.
6. Disconnect the transfer case shift linkage for manual transfer cases, disconnect the transfer case shift module for auto shift applications. (Fig 2a, 2b)

FIGURE 2A



FIGURE 2B



7. Disconnect the breather tube
8. Disconnect the transmission mount from the transmission crossmember (3 nuts). Retain nuts. (Fig 3)

FIGURE 3



9. Remove the mount from the transmission (4 bolts), retain bolts. (Fig 4a, 4b)

FIGURE 4A

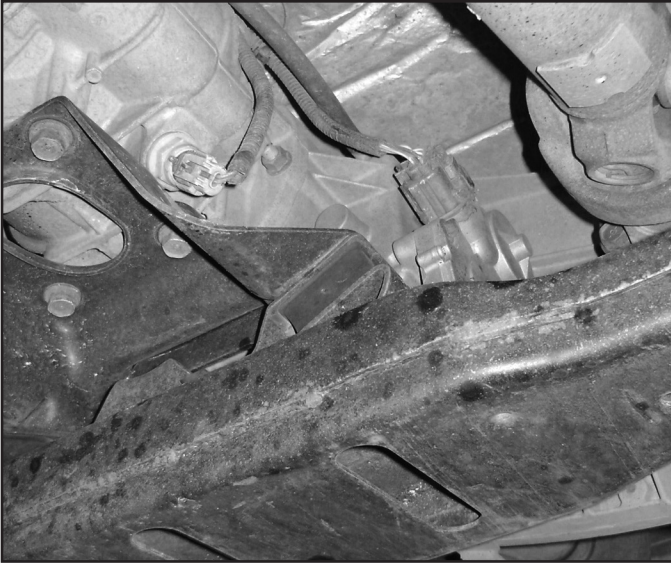

FIGURE 4B



10. Remove the 4 bolts that hold the transmission crossmember into position. Mark the front side of the crossmember and remove from vehicle. (Fig 5a, 5b)

FIGURE 5A



FIGURE 5B



11. Remove the 4 bolts that attach the front driveshaft to the transfer case. (Fig 6a, 6b)

FIGURE 6A



FIGURE 6B



12. Support the transfer case and remove the 6 nuts that attach the transfer case to the transmission. (Fig 7a, 7b)

FIGURE 7A

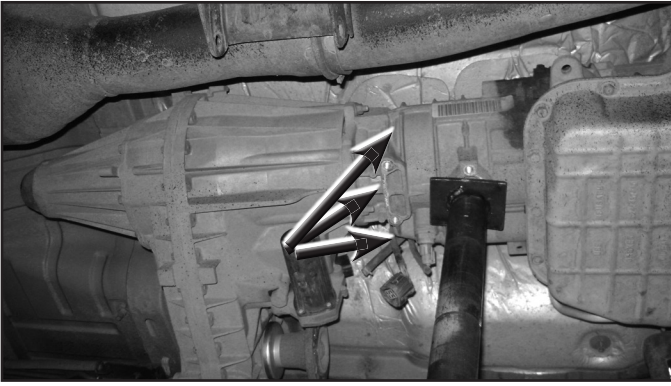

FIGURE 7B



13. Remove the transfer case from the vehicle.
14. Clean the mounting surfaces from any corrosion or oxidation that may be present.
15. Remove the studs from the transfer case. Thread on up to 3 nuts in order for there to be enough resistance to unthread the studs. (Fig 8)

FIGURE 8



16. Install the transfer case indexing ring onto the transfer case. Note: This will only go on one way, rotate until the holes line up, attach with counter sunk allen bolts with thread locker on threads. Ensure the ring goes on square and there are no gaps. Tighten to 35 ft-lbs. (Fig 9, 10).

FIGURE 9

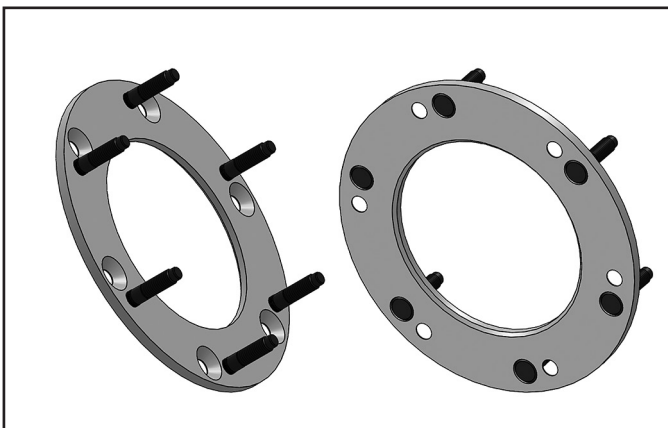
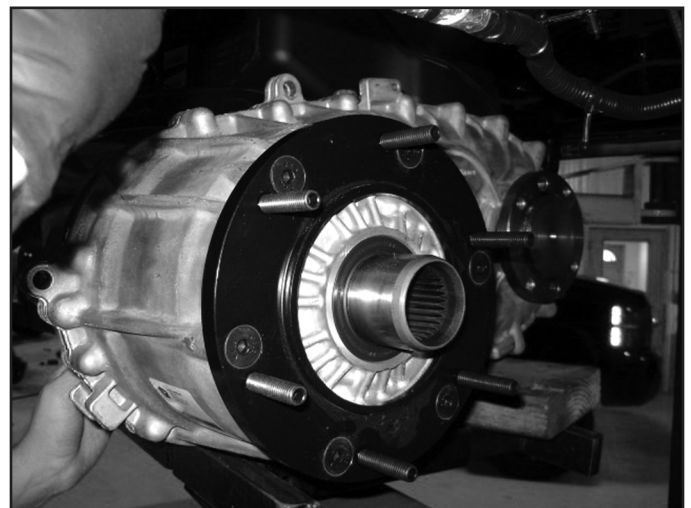

FIGURE 10



17. Reinstall the transfer case and tighten with 3/8" fine thread nuts with washers. Apply thread locker and tighten to 45 ft-lbs. Note: This torque applies with the thread locker still slightly damp and acting as a lubricant. The max recommended torque is 55 ft-lbs when rechecking hardware. (Fig 11)

FIGURE 11



18. Reattach the breather line and electric connection for auto shift 4x4 models. Attach the shift linkage for manual shift transfer case models.

 **Tip** Before hooking up the front driveshaft, now is a great time to grease the nearly impossible to access grease fitting on the front dual cardan joint. A needle adaptor on a grease gun is required. This fitting is required to be serviced at every oil change interval. Ensure that this maintenance is not skipped!

19. Reinstall front driveshaft with driveshaft spacer and new hardware if it is being installed with 6 inches or more of lift. If there is less than 6 inches of lift, do not use the driveshaft spacer and reuse the factory hardware. Use thread locker on threads and tighten to 75 ft-lbs. Bolt pack # 932. Note: Certain aftermarket kits may not require the driveshaft spacer. It is the installers responsibility to ensure that the drive-shaft has adequate engagement and install or skip the installation of the included spacer.
20. Reinstall the transmission mount with OE hardware, tighten to 35 ft-lbs.
21. Reinstall the transmission crossmember with factory bolts, and tighten to 95 ft-lbs..
22. Reinstall the rear driveshaft with factory hardware, use thread locker on threads, tighten to 75 ft-lbs. If the vehicle is equipped with a carrier bearing, install carrier bearing drop at this time (sold separately) if the kit is being installed with a lift 4" or taller.
23. Check the shift linkage for manual shift transfer cases. Adjust the linkage as necessary to allow all gear ranges to be selected.
24. Recheck all fasteners for proper torque, recheck again after 500 miles.



WE WANT TO SEE YOUR RIDE!

Grab photos of your BDS-equipped truck in action and send them in for a chance to be featured. Send it in to our Bad Ass Rides customer gallery at bds-suspension.com/bar and post them on the BDS Fan Page on Facebook at facebook.com/BDSSuspensions. Don't forget about your BDS swag! BDS offers t-shirts, hoodies, decals and more available on the BDS website or through your local BDS distributor.

TIME TO HAVE SOME FUN

Thank you for choosing BDS Suspension.

For questions, technical support and warranty issues relating to this BDS Suspension product, please contact your distributor/installer before contacting BDS Suspension directly.