

**DODGE RAM / 2500-3500 RAM  
FRONT & REAR MUD GUARDS - INSTALLATION INSTRUCTIONS**

*Install paint protection film before mud guard (see other side).  
Please read instructions thoroughly before installation.*

**Tools Required:**

- 1/8" & 1/4" drill bits / Drill
- Center punch / Hammer
- Short Phillips screwdriver or drill attachment
- Marking utensil (fine tip marker, grease pencil, etc.)

**Package Contents**

- Driver & passenger side mud guard
- #10 SEM screw (qty. 8)
- Plastic fastener (qty. 2)
- U-clip (for rear mud guard only) (qty. 4)
- Paint Protection Film (1 set)
- Instruction sheet (front & rear)

**FRONT MUD GUARD INSTALLATION**

**NOTE:** Turn the front wheels all the way to the left or right for mud guard installation. However, it may be necessary to remove the wheels depending on the tools being used for installation.

1. Clean and degrease the mud guard location area on the fender before installation.
2. Using the mud guard as a template, position and mark hole location B with a marking utensil. Make sure the mud guard fits flush against the front fender and is parallel to the ground (figure 1).
3. Center punch and drill 1/8" hole at location B.
4. Attach mud guard to front panel with #10 SEM screw, check fit and alignment. Adjust accordingly.
5. Center punch and drill 1/8" holes at locations A, C and D using the mud guard as a template.
6. Install #10 SEM screws at locations A, C and D, check fit and tighten.
7. Using mud guard as a template, drill a 1/4" hole at location E.
8. Install plastic fastener at location E attaching the mud guard to the fender liner.

**REAR MUD GUARD INSTALLATION**

**NOTE:** It may be necessary to remove the rear wheels depending on the tools being used for installation.

9. Clean and degrease the mud guard location area on the rear panel before installation.
10. Remove existing fasteners (either plastic rivets or factory sheet metal screws) from locations B and D (see figure 2). If vehicle has factory sheet metal screws in locations B and D, remove and save for reuse (SKIP STEP 11). If fasteners are plastic rivets, break to remove and discard.
11. Pull liner out and install U-clips over liner at locations B and D (see figure 3), return liner to original position.
12. Attach mud guard to rear panel with #10 SEM screws or existing factory sheet metal screws at locations B and D.
13. Center punch and drill 1/8" hole at locations A and C using the mud guard as a template.
14. Install #10 SEM screws at locations A and C, check fit and tighten.
15. Using mud guard as a template, drill 1/4" hole at location E.
16. Install plastic fastener at location E attaching the liner to the mud guard.



Figure 1

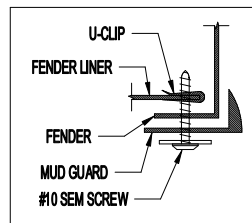

Figure 3

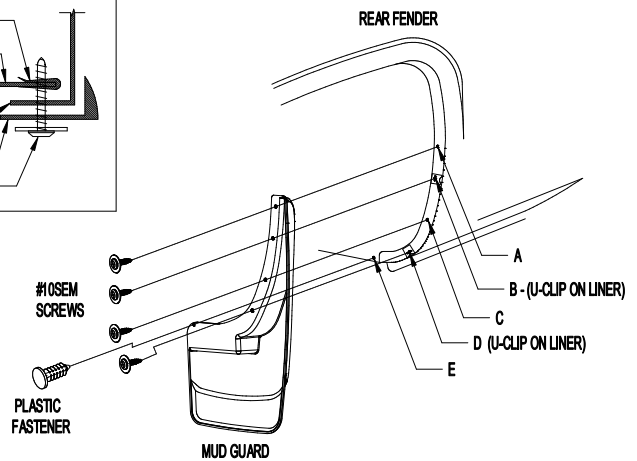

Figure 2

**PAINTING INSTRUCTIONS**

**Note:** *If painting mud guards, perform a mud guard test fit to ensure correct fit and application prior to painting.*

1. Clean mud guard with a soap and water solution to remove dirt and other contaminants.
2. Sand painting surface with 320 grit sand paper.



PART NO. **5600**

3. Apply a coating of flexible primer-adhesion promoter.
4. Apply a flexible paint as directed by the paint manufacturer.

#### **PAINT PROTECTION FILM INSTALLATION INSTRUCTIONS**

**NOTE:** *The Paint Protection Film is a precut template of film used to protect the mud guard mounting surfaces of your fenders against wear. The templates (left and right side) can be removed from the backing liner by folding the liner at the center cut of the template, separating the film sides and peeling the film templates from the backing liner.*

1. Position mud guard on fender to indicate placement location of paint protection film.
2. Clean the placement area of fender with a clean cotton cloth and a petroleum distillate based cleaner such as DuPonts Prep-Sol Brand Solvent Cleaner or 3M Brand Adhesive Cleaner and dry.
3. Mix a wetting solution of 1 pint of water with 4 drops of liquid dishwashing detergent.
4. Mark correct position of film by placing mud guard against fender. **Make sure film extends beyond edge of mud guard contour a minimum of an 1/8".**
5. Remove protection film from liner and flood adhesive side of film with wetting solution (use a spray bottle or sponge).
6. Thoroughly wet film placement location of fender with wetting solution.
7. Position the adhesive side of film on fender and flood with wetting solution.
8. Check location of film with mud guard and reposition as necessary.
9. Using a sponge, squeegee any air bubbles and wrinkles from film.
10. Allow film to dry before installing mud guard.

