



FITTING INSTRUCTIONS

Part Number: 4440140 / 4440150 / 4440160 / 4440170
Product 4440140 – S/STEP RANG/BT50 11ON LRG RAD
Description: 4440150 – F/RAIL RANG/BT50 11ON LRG RAD
4440160 – RETURN RANG/BT50 11ON LRG RAD
4440170 – SUMMIT F/RAIL BT50 11ON

Suited to vehicle/s: **SUMMIT SIDE STEPS / RAILS / RETURNS FORD RANGER (PX) AND MAZDA BT50 2011 ON (BOTH T6 PLATFORM) – DUAL CAB AND EXTRA CAB**

WARNING

REGARDING VEHICLES EQUIPPED WITH SIDE AIR CURTAINS & SIDE AIRBAGS:

When installed in accordance with these instructions, the Side Step and Side Rail does not affect operation of the Side Air Curtains and Side Airbags.

ALSO, NOTE THE FOLLOWING:

- ◆ This product must be installed exactly as per these instructions using only the hardware supplied.
- ◆ In the event of damage to any Side Step and Side Rail component, contact your nearest authorised ARB stockist. Repairs or modifications to the impact absorption system must not be attempted.
- ◆ Do not use this product for any vehicle make or model, other than those specified by ARB.
- ◆ This product or its fixing must not be modified in any way.
- ◆ The installation of this product may require the use of specialized tools and/or techniques
- ◆ It is recommended that this product is only installed by trained personnel
- ◆ These instructions are correct as at the publication date. ARB Corporation Ltd. cannot be held responsible for the impact of any changes subsequently made by the vehicle manufacturer
- ◆ During installation, it is the duty of the installer to check correct operation/clearances of all components
- ◆ Work safely at all times

Unless otherwise instructed, tighten fasteners to specified torque

ARB 4x4 ACCESSORIES

Corporate Head Office

42-44 Garden St
Kilsyth, Victoria.
AUSTRALIA. 3137.

Tel: +61 (3) 9761 6622
Fax: +61 (3) 9761 6807

Australian enquiries
North & South American enquiries
Other international enquiries

sales@arb.com.au
sales@arbusa.com
exports@arb.com.au

www.arb.com.au

GENERAL CARE AND MAINTENANCE

By choosing an ARB Side Step and Side Rail, you have bought a product that is one of the most sought after 4WD products in the world. Your step and rail is a properly engineered, reliable, quality accessory that represents excellent value. To keep your step and rail in original condition it is important to care and maintain it following these recommendations:

- Prior to exposure to the weather your step and rail should be treated to a Carnauba based polish on all exposed surfaces. It is recommended that this is performed on a six monthly basis or following exposure to salt, mud, sand or other contaminants.



As part of any Pre Trip Preparation, or on an annual basis, it is recommended that a thorough visual inspection of the step and rail and surrounding components is carried out, making sure that all bolts are torqued to the correct specification. Also check that nearby wiring and plumbing are free of damage. Replace any components as necessary. This service can be performed by your local authorized ARB Stockist.

FITTING REQUIREMENTS

REQUIRED TOOLS FOR FITMENT OF PRODUCT:

Basic tool kit	Silicon
Masking tape	Power drill – (Ø13mm Capacity)
Axle stands (optional)	Ø4, Ø8 & Ø12mm Drill Bits
Torque Wrench/Wrenches - (5Nm TO 100Nm)	Metric Stepped Drill (with Ø24mm Step)
Scissors or Stanley Knife	Centre Punch
Rust Preventing Paint - Black	½” Drive Allen Key Set - (8mm Allen Key Bit).

HAVE AVAILABLE THESE SAFETY ITEMS WHEN FITTING PRODUCT:

Protective eyewear		Hearing protection	
--------------------	---	--------------------	---

NOTE: 'WARNING' notes in the fitting procedure relate to OHS situations, where to avoid a potentially hazardous situation it is suggested that protective safety gear be worn or a safe work procedure be employed. If these notes and warnings are not heeded, injury may result.

FASTENER TORQUE SETTINGS:

SIZE	Torque Nm	Torque lb/ft
M6	9Nm	7lbft
M8	22Nm	16lbft
M10	44Nm	32lbft
M12 U-BOLTS	44Nm	32lbft
M12	77Nm	57lbft

PARTS LISTING

APPLICATION.	PART NO.	QTY	DESCRIPTION
SIDE STEPS TO VEHICLE 4440140 – S/STEP RANG/BT50 11ON LRG RAD	6562666R	1	RAIL ASSY S/STEP T6 LRG RAD RH
	6562666L	1	RAIL ASSY S/STEP T6 LRG RAD LH
	3194330	6	CAGE PLATE D40 SIDE RAIL (400mm)
	6151305	6	NUT CAGED M12 3.3-4.7
	6151377	2	BOLT 'U' M12 X 1.75 X 175 X 120
	6151360	6	BOLT M12 X 1.75 X 35 Gd 8.8 ZP
	4581007	10	WASHER FLAT 1/2" X 1 1/2" X 4MM ZP
	4581050	6	WASHER SPRING 1/2" X 3/16" X 1/8" ZP
	6151574	4	NUT NYLOC M12 X 1.75 TZP 480
	6500002	2	PLUG RUBBER 60.3 TUBE BLANKING PLUG
	215637	2	DECAL ARB SIDE RAILS
	3194745	2	PLATE S/STEP CLAMP REAR T6
	4584296	2	WASHER OD30 X ID11 X 5MM TZP
	4584377	4	WASHER FLAT M12 X 30 X 5 ZP
	6151374	4	BOLT M12 X 1.75 X 110 GR8.8 ZP
	6151509	2	BOLT M10X1.5X110 GR8 ZP TRIV
5811065	4	SLEEVE S/STEP MOUNT BRKT T6	
SIDE RAILS TO VEHICLE 4440150 – F/RAIL RANG/BT50 11ON LRG RAD	6562668R	1	RAIL ASSY F/RAIL T6 LRG RAD RH
	6562668L	1	RAIL ASSY F/RAIL T6 LRG RAD LH
	6151022	4	BOLT M8X1.25X25 HEX HD ZP GR 8
	4581044	8	WASHER FLAT M8X17X1.6 ZP
	6151032	4	NUT HEX LOCK NYLOC M8 X 1.25
	3194676L	1	PLATE STEP T6 LG RAD F/RAIL LH
	3194676R	1	PLATE STEP T6 LG RAD F/RAIL RH
	4581072	16	WASHER FLAT M6 X 1.6 X 20 TZP
	6151128	16	M6 X 1.0 FLANGE NUT ZP
	6151256	16	S/S M6 X 16 BHCS
	6582464	1	CLAMP KIT S/RAIL NG LG RAD
	6250024	6	SPACER S/STEP / RETURN LG RAD
SIDE RAILS TO VEHICLE 4440170 – SUMMIT F/RAIL BT50 11ON	6562723R	1	RAIL ASSY F/RAIL T6 LRG RAD RH
	6562723L	1	RAIL ASSY F/RAIL T6 LRG RAD LH
	6151022	4	BOLT M8X1.25X25 HEX HD ZP GR 8
	4581044	8	WASHER FLAT M8X17X1.6 ZP
	6151032	4	NUT HEX LOCK NYLOC M8 X 1.25
	3194676L	1	PLATE STEP T6 LG RAD F/RAIL LH
	3194676R	1	PLATE STEP T6 LG RAD F/RAIL RH
	4581072	16	WASHER FLAT M6 X 1.6 X 20 TZP
	6151128	16	M6 X 1.0 FLANGE NUT ZP
	6151256	16	S/S M6 X 16 BHCS
	6582464	1	CLAMP KIT S/RAIL NG LG RAD
	6250024	6	SPACER S/STEP / RETURN LG RAD

SIDE STEP RETURN SECTIONS TO VEHICLE 4440160 – RETURN RANG/BT50 110N LRG RAD	6562667R	1	RAIL S/STEP CAP T6 LRG RAD RH
	6562667L	1	RAIL S/STEP CAP T6 LRG RAD LH
	4581044	8	WASHER FLAT M8X17X1.6ZP
	6151022	4	BOLT M8X1.25X25 HEX HD ZP GR 8
	6151032	4	NUT HEX LOCK NYLOC M8 X 1.25
	6500002	2	PLUG RUBBER 60.3 TUBE BLANKING PLUG
	3194687R	1	PLATE STEP T6 LG RAD RETURN RH
	3194687L	1	PLATE STEP T6 LG RAD RETURN LH
	6151128	16	M6 X 1.0 FLANGE NUT ZP
	6151256	16	S/S M6 X 16 BHCS
	4581072	16	WASHER FLAT M6 X 1.6 X 20 TZP
	6250024	6	SPACER S/STEP / RETURN LG RAD

FITTING PROCEDURE – PREPARATION TO VEHICLE

IMPORTANT NOTE: These instructions apply to both Ranger and BT50. The pictures below may show either vehicle.

1. If fitted, remove the factory side steps retaining all fasteners.
2. Refit the fasteners into the captive nuts in the vehicles body to seal against water ingress.



SIDE STEP FITMENT TO VEHICLE

3. Fit the rubber plugs into the rear most ends of the side rails.

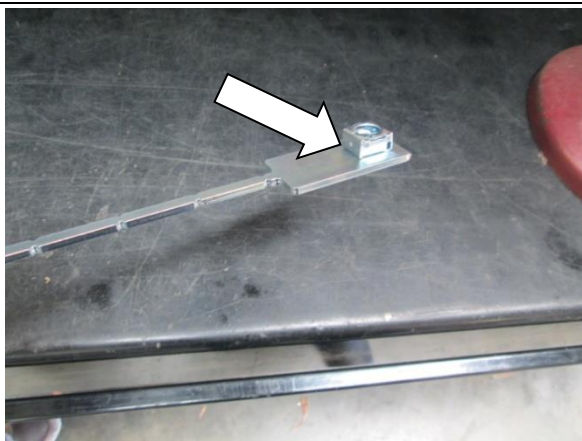

4. Place an M12 caged nut into each of the 6 nut plates.
5. Starting on the right hand (RH) side of the vehicle, locate the holes noted by arrows in the picture.

Note: The next steps are to prepare the nut plates so that they are aligned with the appropriate mount holes.

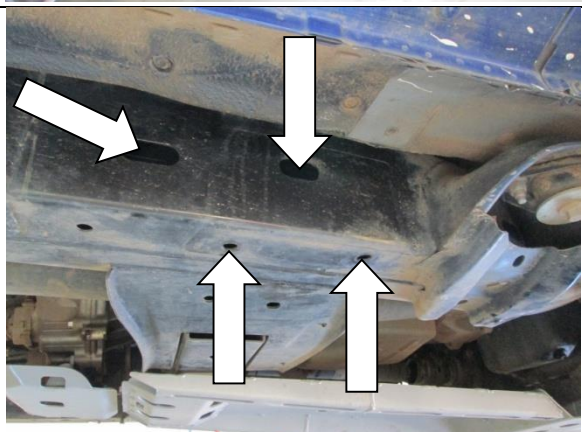

6. Use the large oval slot for access.

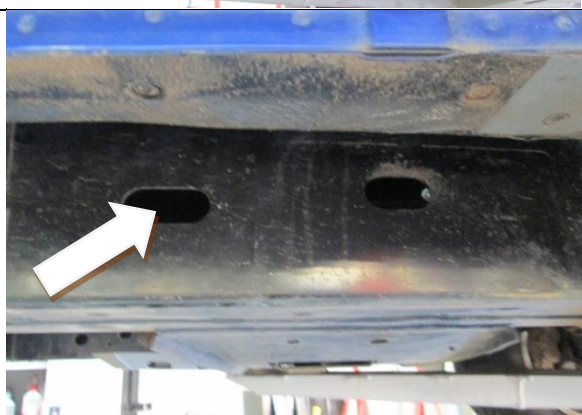

- 7.

SIDE STEP FITMENT TO VEHICLE - CONTINUED



Rearmost Underneath Chassis (above).



Slot on Chassis Side (above).



Frontmost Underneath Chassis (above).

8. Carefully bend the nut plate tails so that you are able to align the cage nuts with the holes in the chassis.

Note: Align the nuts in the following order:

1. Rearmost underneath chassis
2. Slot on the chassis side
3. Forward most underneath chassis

Warning: It is important to only make small adjustments of the nut plate at a time so as not to risk breaking the tail.

(Images at Left Show Nut Plates Bent for RH Step Installation).

9. Repeat for the left hand side (LH)

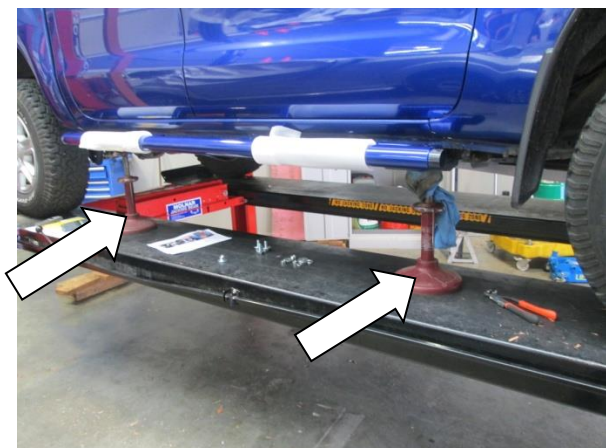

10. Place the RH side step against the chassis as shown. Use adjustable axle stands or a second person to hold the steps in place.

SIDE STEP FITMENT TO VEHICLE - CONTINUED



11. Attach the centre of the step to the chassis using a "U" bolt, M12 Flat Washers and M12 Nyloc Nuts. Leave loose at this stage.



Dual Cab (shown above).
Extra Cab (shown below).

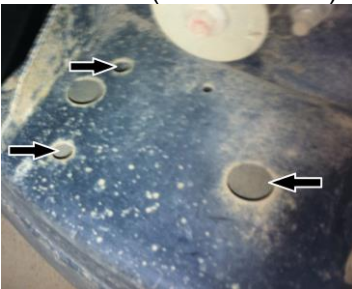

12. Align the rear of the step fastens to chassis using these holes.



13. Install Clamp Plate on inside of chassis rails aligning with holes as shown above.

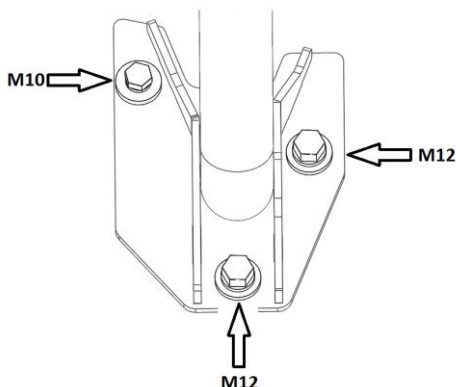

14. Attach the rear of the step to the chassis using the following fasteners but do not fully tighten:

- Bolt M10 x 110, Washer M10 x 30 x 5mm
- Bolt M12 x 110, Washer M12 x 30 x 5mm, and M12 Crush Sleeve.
- Clamp plate (installed Step 12).

Note: Use a liquid thread locking product such as Loctite when fitting both the M10 and M12 bolts.

SIDE STEP FITMENT TO VEHICLE - CONTINUED

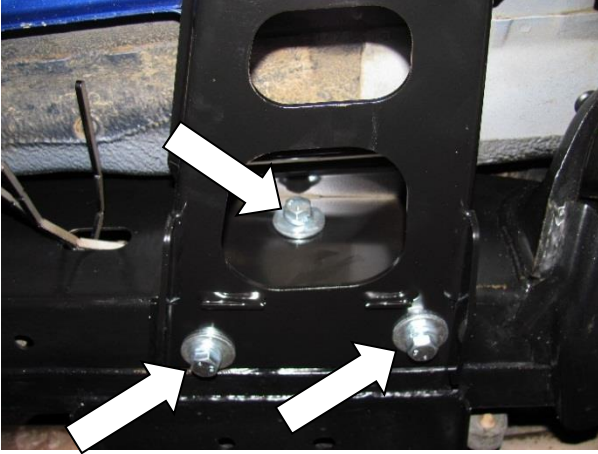

15. Attach the front of the rail to the chassis using M12 Bolts, M12 Spring Washers and M12 Flat Washers into the cage nut plates adjusted in the steps above.
16. Adjust the rail so that it is level with the vehicle and tighten all fasteners to specified torque settings.

Torque to specification.

 M10 44Nm (BOLTS)

 M12 77Nm (BOLTS)

 M12 44Nm ("U" BOLTS)



17. Repeat on the LH side.

NOTE: On LHS installation, use a screwdriver or similar to bend the brake line bracket tail out and away from the hole in the chassis rail that it locates in.

Note: Brake line bracket tail will be found on the inside of the chassis rail opposite the hole indicated in the images below.

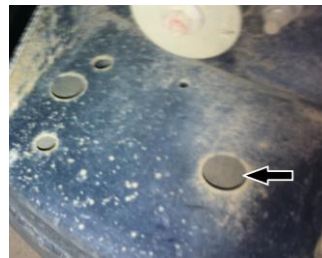

Extra Cab (Shown above).

Dual Cab (Shown below).



FRONT SIDE RAIL FITMENT TO VEHICLE

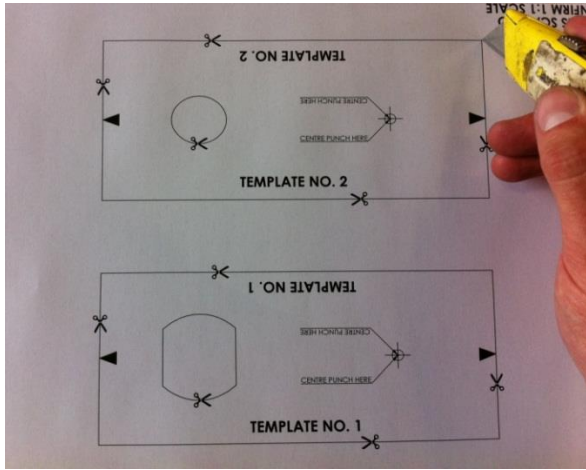

18. Using Scissors or a Stanley Knife carefully cut out Templates 1 and 2 including the 2 x pieces from the inside – (See image).



19. Use masking tape to wrap **1 x layer only** of tape around the Bull Bar Outer Frame to protect it from damage. Ensure masking tape is applied flat and without creases.

WARNING: If more than 1 x layer of masking tape is applied and/or creases are present it will affect the use of the drilling templates and could result in the Bull Bar being incorrectly drilled and not serviceable.

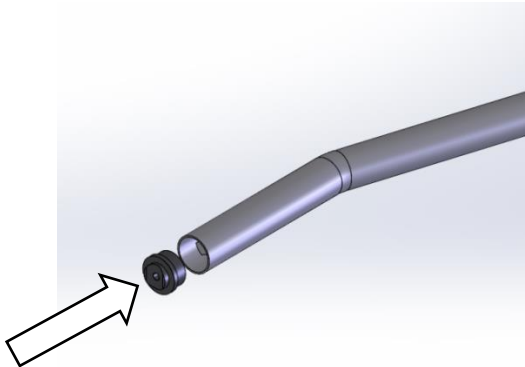

20. Install Tube Spigot into the front of the Side Rail – Install without spacers fitted.

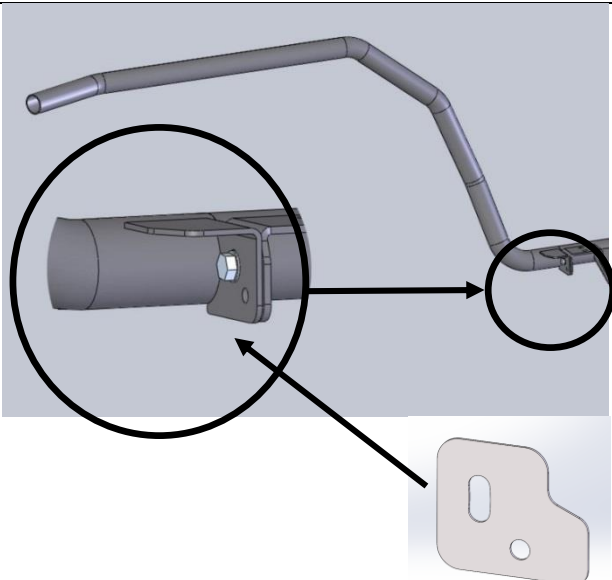

21. On the RH side, place the Front Side Rail assembly onto the end of the Side Step Rear section as shown and attach using an M8X20 Bolt, 2 x M8 Flat Washers and an M8 Nyloc Nut.

Note: Up to 3 x 6250024 - SPACER S/STEP / RETURN LG RAD may be installed between Side Step and Side Rail Brackets to obtain better fitment.

Note: Do not fully tighten at this stage.

FRONT SIDE RAIL FITMENT TO VEHICLE - CONTINUED



22. Hold Side Rail so that when viewed from the side of the vehicle the top tube is horizontal (**parallel to the ground**) and the Side Rail sits as desired against the side of the vehicle.
23. Offer Side Rail/Tube Spigot up to the back of the Bull Bar outer frame. – If a gap exists slide Tube Spigot forwards until it contacts the Bull Bar outer frame.



24. Set distance from top face of the bull bar wing to bottom of rail to 75mm +/- 2mm for correct set up.

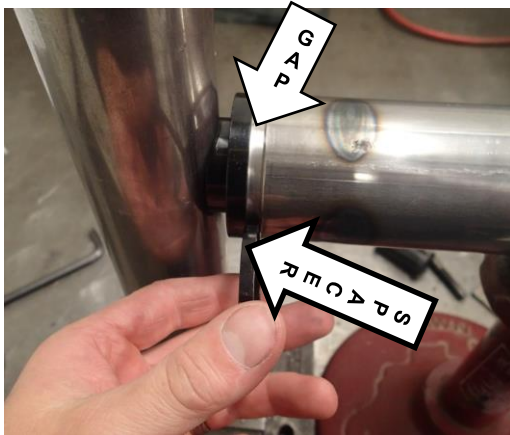

25. Assess the gap between the front end of the Side Rail and the Tube Spigot. Select the closest matching Spacer/Spacers to fill the gap. (Spacer options: Nil / 5mm / 10mm or 15mm (5mm + 10mm Spacers).
 - **Note: If the gap is too large for the Spacers to fill or too small (ie. the tube spigot cannot be fitted) adjustment of the Bull Bar and/or Side Step may be required.**



26. Swing the Side Rail outwards and away from the vehicle allowing installation of appropriate/selected spacer into gap between the front end of the Side Rail and the Tube Spigot. (5mm in this instance).



27. Swing the Side Rail inwards and install “TEMPLATE 1” between the end of the Tube Spigot and the Bull Bar outer frame

FRONT SIDE RAIL FITMENT TO VEHICLE - CONTINUED

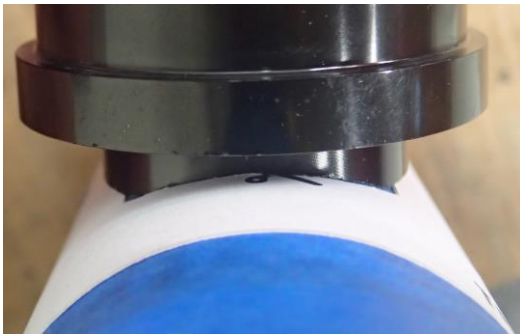

28. Carefully align and centre “TEMPLATE 1” with the end of the Tube Spigot and wrap around the Outer Frame Tube.

- **Note: Ensure the indicator arrows are aligned before taping into position with Masking Tape – (AS SHOWN).**

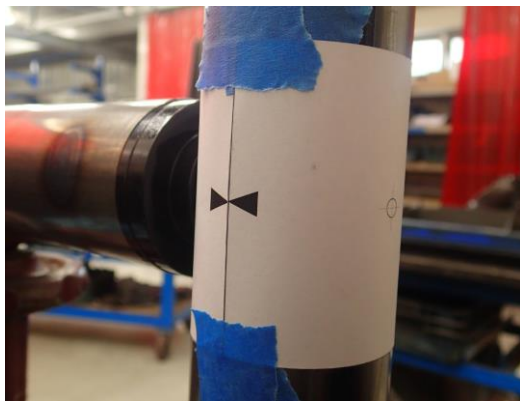

29. Using a Centre Punch, carefully Centre Punch the outer frame at the centre mark of “TEMPLATE 1”.
30. Remove Side Rail and set aside.
31. Remove “TEMPLATE 1”.

- Note: Do not discard.** Template will be re-used for the opposite side clamp installation.

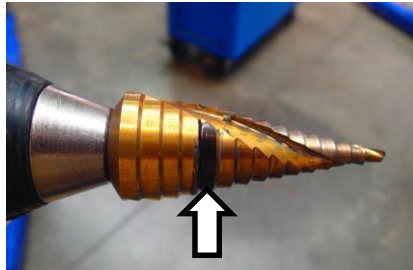
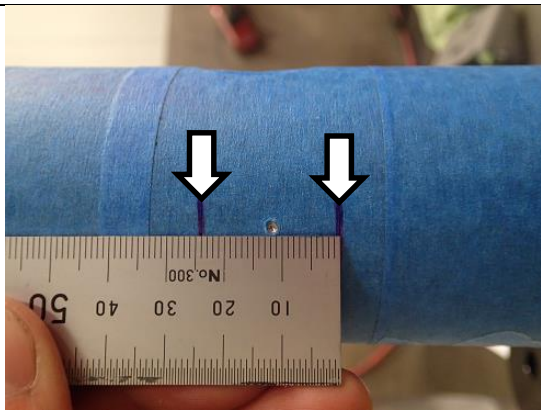

32. Using a marker pen, mark the outer frame 12mm above and below the Centre Punch mark (12mm + 12mm = 24mm).

- **Note: These marks on the outer frame give an indication of how far to drill with the Stepped Drill.**

33. Using a marker pen, mark the Ø24mm step on the Stepped Drill.

-**Note: These marks on the Stepped Drill give an indication of how far to drill to achieve the correct diameter hole in the outer frame.**

FRONT SIDE RAIL FITMENT TO VEHICLE - CONTINUED

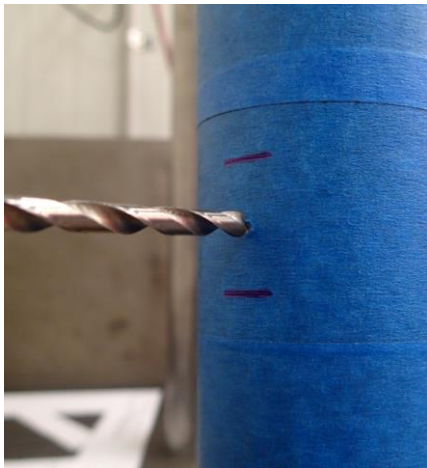

34. At the location of the Centre Punch mark, use an Ø4mm (or similarly sized) Drill Bit to drill a pilot hole through the front face of the Bull Bar outer frame.

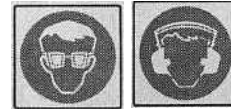

Warning: Drilling operations can result in flying metal debris, safety glasses should be worn.



35. Use a Stepped Drill Bit to drill the Ø4mm pilot hole out to Ø24mm.

WARNING - Do not drill past the 24mm marks on the outer frame or the Ø24mm mark on the Stepped Drill - Drilling too far will destroy the Bull Bar.



Warning: Drilling operations can result in flying metal debris, safety glasses should be worn.

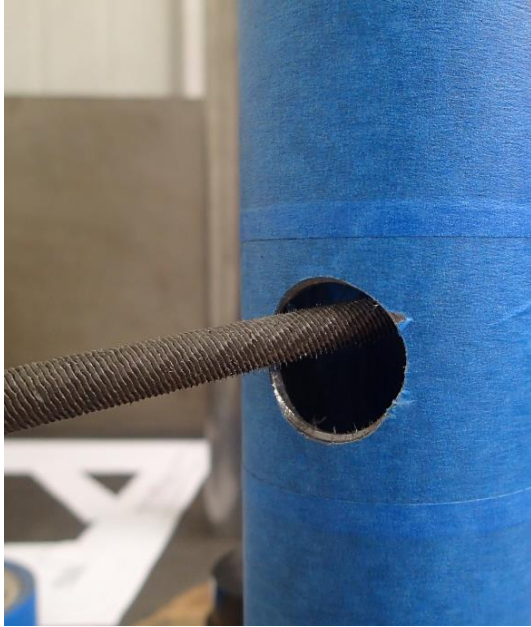

36. Using a small Round or Half-Round File carefully remove any burrs from the edge of the $\text{\O}24\text{mm}$ hole.

-Note: Care should be taken to avoid damaging the outer frame paintwork surrounding the $\text{\O}24\text{mm}$ hole.

FRONT SIDE RAIL FITMENT TO VEHICLE - CONTINUED



37. Carefully align "TEMPLATE 2" and centre over the $\text{\O}24\text{mm}$ hole. Wrap around the Outer Frame Tube.

- **Note: Ensure the indicator arrows are aligned before taping into position with Masking Tape – (AS SHOWN).**

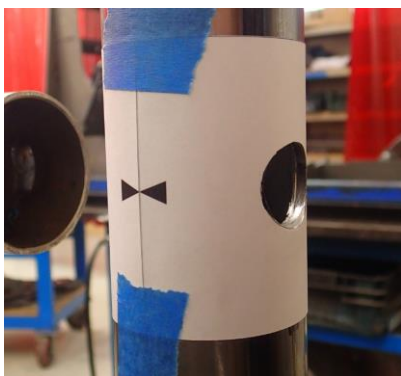

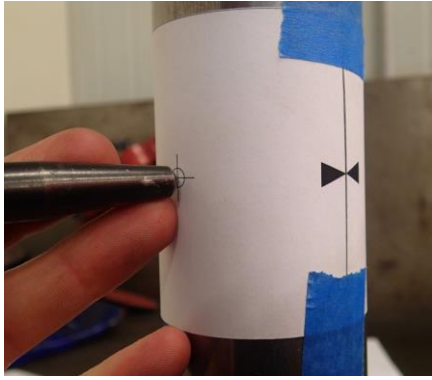

38. Using a Centre Punch, carefully Centre Punch the outer frame at the centre mark of "TEMPLATE 2".
 39. Remove "TEMPLATE 2".
- Note: Do not discard.** Template will be re-used for the opposite side clamp installation.



40. At the location of the Centre Punch mark, use an Ø4mm (or similarly sized) Drill Bit to drill a pilot hole through the front face of the Bull Bar outer frame.
41. Use an Ø12mm Drill Bit to drill the Ø4mm pilot hole out to Ø12mm.



Warning: Drilling operations can result in flying metal debris, safety glasses should be worn.

FRONT SIDE RAIL FITMENT TO VEHICLE - CONTINUED



42. Using a small Flat or Half-Round File carefully remove any burrs from the edge of the Ø12mm hole.
- **Note: Care should be taken to avoid damaging the outer frame paintwork surrounding the Ø12mm hole.**



43. Clean and paint with Rust Preventative Paint any exposed/bare metal surfaces left after drilling.
- **Note: Use tape/paper to mask surrounding areas to avoid getting paint overspray in undesired locations.**

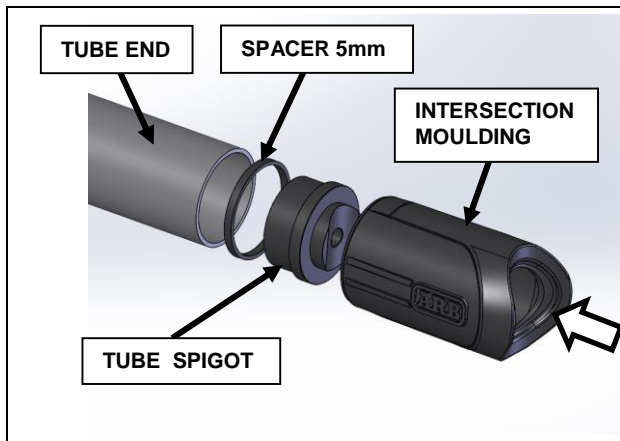

44. Install Tube Spigot, selected Spacer/Spacers and Intersection Moulding into place on the Side Rail.

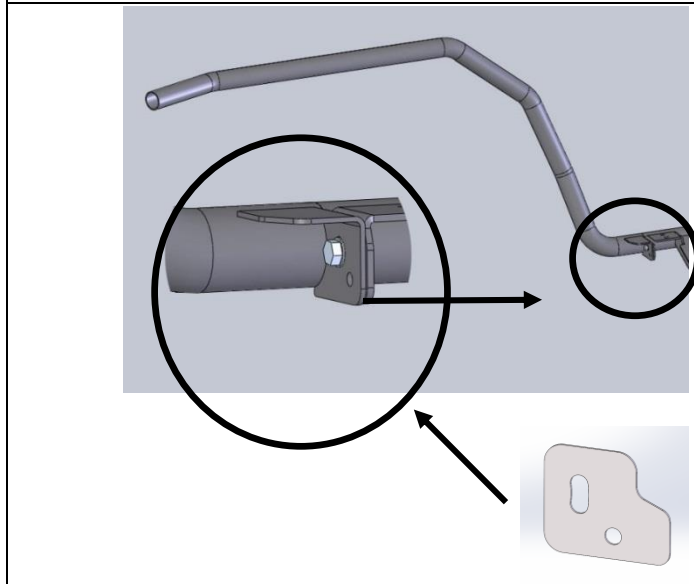

45. Install Side Rail (with clamp components fitted) onto Side Step spigot and attach using an M8X20 Bolt, 2 x M8 Flat Washers and an M8 Nyloc Nut.

Note: Up to 3 x 6250024 - SPACER S/STEP / RETURN LG RAD may be installed between Side Step and Side Rail Brackets to obtain better fitment.

Note: Do not fully tighten at this stage.

FRONT SIDE RAIL FITMENT TO VEHICLE - CONTINUED



46. Install Submerged Bush and M10 Bolt.

Torque to Specification.



M10 57Nm **(CRITICAL)**.



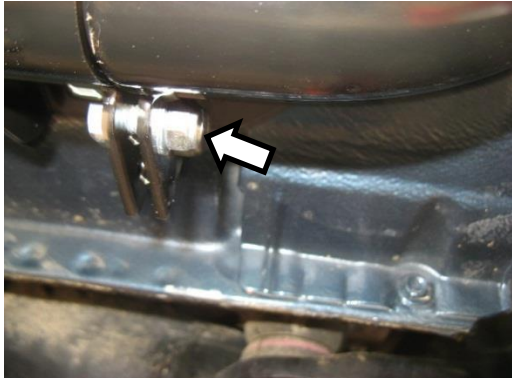

47. Tighten M8 Bolt ensure the slot and holes in the 6250024- SPACER S/STEP / RETURN LG RAD are aligned with the holes in the Step / Side Rail Brackets.

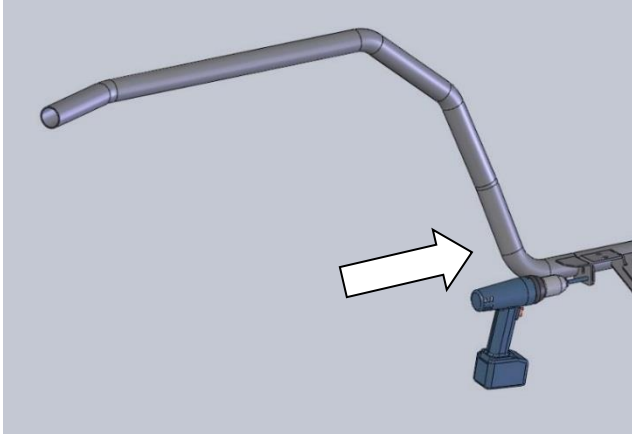

48. Using an electric drill with an Ø8mm drill bit and the pre-cut hole in the front side rail as a guide, drill through the rear section.

NOTE: IT MAY BE NECESSARY TO TEMPORARILY REMOVE THE MUD FLAPS TO GAIN ACCESS WITH THE DRILL.

49. Apply paint or a rust preventative to the bare metal.



Warning: Drilling operations can result in flying metal debris, safety glasses should be worn.

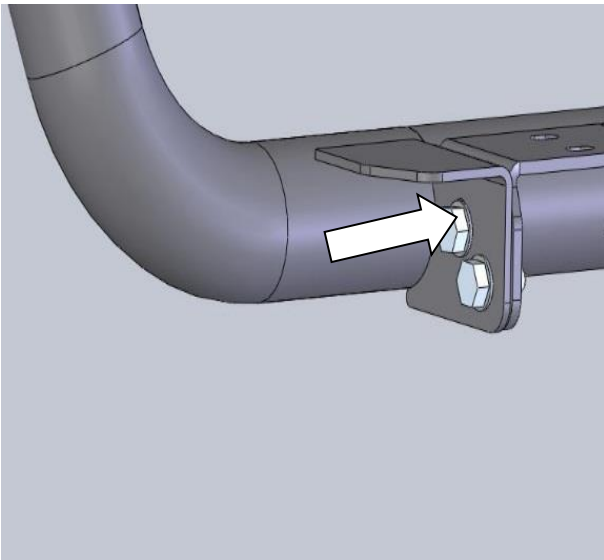

50. Pin the front side rail to the rear section using an M8X20 Bolt, 2 x M8 Flat Washers and an M8 Nyloc Nut.

Torque to Specification.



SIDE STEP RETURN FITMENT TO VEHICLE.

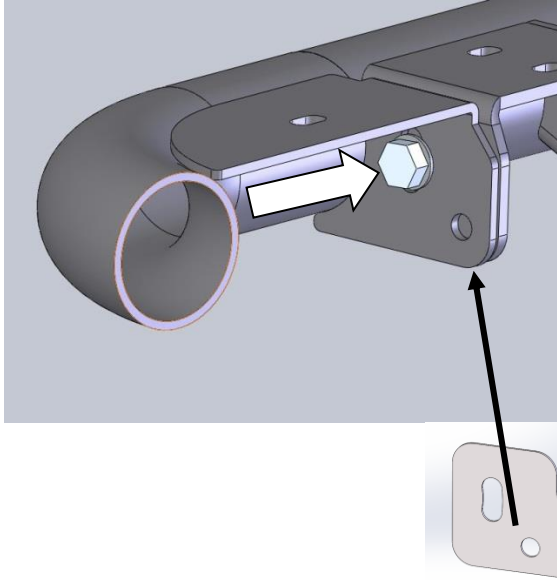

FITTING CURVED END SECTIONS

51. On the RH side fit the curved end section onto the side rail as shown and attach using an M8X20 Bolt, 2 x M8 Flat Washers and an M8 Nyloc Nut.

Note: Up to 3 x 6250024 - SPACER S/STEP / RETURN LG RAD may be installed between Side Step and Side Rail Brackets to obtain better fitment.

52. Ensure the top faces of the curved section and the side rail are parallel and tighten the fasteners.

Torque to Specification.



FRONT SIDE RAIL & SIDE STEP RETURN FITMENT TO VEHICLE

53. Using an electric drill with an Ø8mm drill bit and the pre-cut hole in the curved end section as a guide, drill through the rear section.

NOTE: IT MAY BE NECESSARY TO TEMPORARILY REMOVE THE MUD FLAPS TO GAIN ACCESS WITH THE DRILL.



Warning: Drilling operations can result in flying metal debris, safety glasses should be worn.

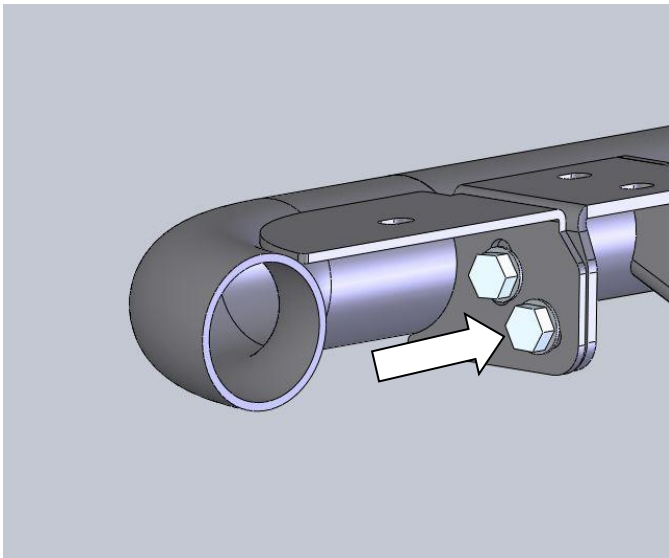

54. Apply paint or a rust preventative to the bare metal.
55. Pin the curved end section to the rear section using an M8X20 Bolt, 2 x M8 Flat Washers and an M8 Nyloc Nut.

Torque to Specification.



FRONT SIDE RAIL & SIDE STEP RETURN FITMENT TO VEHICLE

THE FOLLOWING STEPS APPLY TO BOTH SIDE RAIL AND FRONT SECTION FITMENT



56. Run a bead of silicon along the top of the rail where the Tread Plate will sit. (This will help prevent vibration).
57. Position the Tread Plate on the step, aligning the bolt holes with the corresponding holes in the side step. Starting at the front of the step, secure the checker top with S/Steel M6X16 Button Head Bolts, M6 Flat Washers and M6 Flange Nuts.

Note: Over tightening of bolts may result in damage to the Tread Plates.

Torque to Specification.



M6 5Nm – (CRITICAL)



58. If fitting front rails, apply the supplied ARB decals here on both the RH and LH sides of the vehicle.

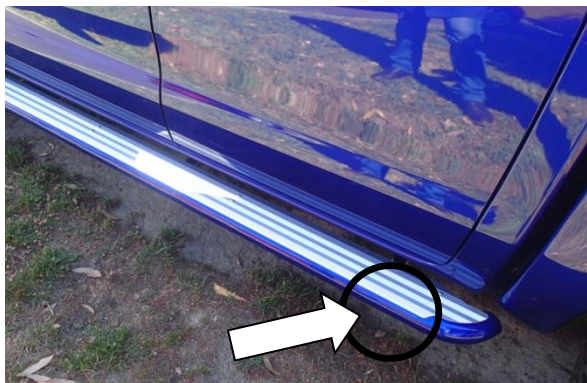

59. If fitting curved front sections, apply the supplied ARB decals here on both the RH and LH sides of the vehicle.

FITTED PRODUCT

