



# FITTING INSTRUCTIONS

Part Number: **3450540 & 3950240**  
Description: **JEEP WRANGLER JL WINCH BAR**  
Suits vehicles: **JEEP WRANGLER JL MY2018 ON**  
Optional Kits: **3550150 WINCH COVER PANEL KIT (3450540)**  
**3550120 WINCH COVER PANEL KIT (3950240)**  
**3550230 SUPPLEMENTARY F/KIT 3450440 TO RUBICON**

**\*NOT COMPATIBLE WITH WINCH ROLLER FAIR LEADS\***

## WARNING

### REGARDING VEHICLES EQUIPPED WITH SRS AIRBAG:

When installed in accordance with these instructions, the front protection bar does not affect operation of the SRS airbag.

### ALSO, NOTE THE FOLLOWING:

- ◆ This product must be installed exactly as per these instructions using only the hardware supplied.
- ◆ In the event of damage to any bull bar component, contact your nearest authorised ARB stockist. Repairs or modifications to the impact absorption system must not be attempted.
- ◆ Do not use this product for any vehicle make or model, other than those specified by ARB.
- ◆ Do not remove labels from this bull bar.
- ◆ This product or its fixing must not be modified in any way.
- ◆ The installation of this product may require the use of specialized tools and/or techniques
- ◆ It is recommended that this product is only installed by trained personnel
- ◆ These instructions are correct as at the publication date. ARB Corporation Ltd. cannot be held responsible for the impact of any changes subsequently made by the vehicle manufacturer
- ◆ During installation, it is the duty of the installer to check correct operation/clearances of all components
- ◆ Work safely at all times
- ◆ Unless otherwise instructed, tighten fasteners to specified torque

## ARB 4x4 ACCESSORIES

Corporate Head Office

42-44 Garden St  
Kilsyth, Victoria  
AUSTRALIA 3137

Tel: +61 (3) 9761 6622  
Fax: +61 (3) 9761 6807

Australian enquiries  
North & South American enquiries  
Other international enquiries

sales@arb.com.au  
sales@arbusa.com  
exports@arb.com.au

[www.arb.com.au](http://www.arb.com.au)

# GENERAL CARE AND MAINTENANCE

By choosing an ARB Bar, you have bought a product that is one of the most sought after 4WD products in the world. Your bar is a properly engineered, reliable, quality accessory that represents excellent value. To keep your bar in original condition it is important to care and maintain it following these recommendations:



Prior to exposure to the weather your bar should be treated to a Carnauba based polish on all exposed surfaces. It is recommended that this is performed on a six monthly basis or following exposure to salt, mud, sand or other contaminants.

As part of any Pre Trip Preparation, or on an annual basis, it is recommended that a thorough visual inspection of the bar is carried out, making sure that all bolts and other components are torqued to the correct specification. Also check that all wiring sheaths, connectors, and fittings are free of damage. Replace any components as necessary. This service can be performed by your local authorized ARB Stockist.

## REQUIRED TOOLS FOR FITMENT OF PRODUCT:

Metric socket and spanner sets 8-25mm range	External Circlip pliers
Screwdrivers, Philips and Flat blade	Paint black fast drying
Torque Wrench	Tape Measure
Half round file	Soft Hammer
Metric hex & torx key set	Loctite© 262 or equiv.
Wide masking tape (low tack)	Angle Grinder with Disc for metal cutting
Small Spirit Level	300mm rule
Black Silicon	

## HAVE AVAILABLE THESE SAFETY ITEMS WHEN FITTING PRODUCT:

Protective eyewear		Hearing protection	
--------------------	---	--------------------	---

**NOTE: 'WARNING' notes in the fitting procedure relate to OHS situations, where to avoid a potentially hazardous situation it is suggested that protective safety gear be worn or a safe work procedure be employed. If these notes and warnings are not heeded, injury may result.**

## FASTENER TORQUE SETTINGS:

	SIZE	Torque Nm	Torque lbft
	M4	2.5Nm	1.8lbft
	M6	9Nm	7lbft
For plastic buffers	M6 (trilobial)	6Nm	4.4lbft
	M8	22Nm	16lbft
	M10	44Nm	32lbft
	M12	77Nm	57lbft
	3/8"	44Nm	32lbft

## PARTS LISTING

APPLICATION.	PART NO.	QTY	DESCRIPTION
<b>WINCH FITMENT KIT</b>	6151357	2	BOLT SEMS M10 X 30 ZP GRADE 8.8
	180302	10	CABLE TIE 4.8 X 180MM BLACK
	6151073	4	BOLT HX HD 3/8" x 1.5 GR8.8 TZP480
	4581040	4	WASHER FLAT M10 X 25 X 3 ZP
	6151321	2	NUT FLANGE M10
<b>CHASSIS MOUNTING KIT</b>	6151357	8	BOLT SEMS M10 X 30 ZP GRADE 8.8
	6151768	2	BOLT M12 X 1.75 X 170MM
	5818167	2	CRUSH TUBE 17X12.5X82
	4581049	4	WASHER FLAT 1/2"
	5848346	2	PACKER JEEP
	6151574	2	NUT NYLOC M12X1.75 PC8
	4654945	2	IMPACT ABSORBER SUITS JL
<b>CONTROL BOX BRACKET KIT</b>	6151262	2	BOLT M8 X 20MM BLACK
	4581075	2	WASHER FLAT M8 BLACK
	3756262	1	CONTROL BOX BRACKET
	6151132	2	NUT FLANGE M8
<b>LIGHT BRACKET KIT</b>	3759320	2	BRACKET LIGHT BOLT ON
	4581075	8	WASHER FLAT M8 BLK ZN
	6151547	4	NUT HEX NYLOC M8 x 1.25 GR8.8 ZP
	6151234	4	BOLT M8 x 1.25 x 25 Gd 8.8 BP
<b>BUFFER KIT</b>	3163008	2	BUFFER JEEP WRANGLER
	6151372	8	SCREW PLASTITE, TRILOBIAL 14-10X1
<b>PARKING SENSORS</b>	3163222	6	PLUG SENSOR BLANKING
	3501060	1	SENSOR SURROUND KIT
<b>FOG LIGHT FITTING KIT</b>	6151262	4	BOLT M8 X 1.25 X 20 Gd 8.8 BZ
	4581075	4	WASHER FLAT, M8 BLK ZN
	4584294	8	WASHER FLAT M4X9X0.85 TZP 480
	6151132	4	FLANGE NUT M8
	3750394L	1	BRKT LED FOG MOUNT JL LH
	3750394R	1	BRKT LED FOG MOUNT JL RH
	6151404	8	NUT FLANGE M4
	6151254	8	SCREW PAN HD M4X20
<b>NON-WINCH PAN COVER KIT (ACCESSORY Part No 3550150/3550120)</b>	6151132	4	FLANGE NUT M8
	3314940/3314930	1	PAN COVER
	6151021	4	BOLT M10 X 1.5 X 20 HEX HD GR8.8 ZP
	4581307	4	WASHER FLAT, M8 X 20 X 2 BLK ZN
<b>NUMBER PLATE BRACKET ASSEMBLY</b>	3758963	1	BRACKET NUMBER PLATE PIVOT
	3758964	1	BRACKET NUMBER PLATE MOUNT
	5848302	2	PACKER RB NYLON
	6151561	6	NUT FLANGE M6 X 1.0 BTZP480
	6151223	2	NUT NYLOC M6 X 1.0 BZ
	6151256	4	SCREW BUTTON HD M6 X 16 SS
	4584327	6	WASHER F M6 X 16 X 1.2 BTZP 480
	6151213	4	BOLT M6 X 1.0 X 20 GD 8.8 ZP
4581304	4	WASHER FLAT M6 SS	

## FITTING PROCEDURE



1. Remove plastic splash panel from underneath bumper by removing 2 lower screws and prying apart 8 plastic grommets,



For Rubicon vehicles fitted with steel under panel, remove by unbolting from chassis brackets and lower edge of steel bumper.

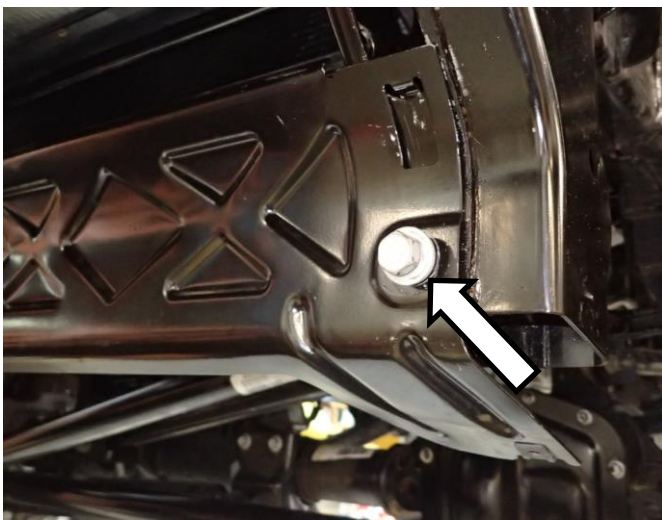

2. Remove front steel panel by removing both mounting bolts.



3. Disconnect fog light/parking sensor harness, located on the RHS chassis rail, access from wheel arch.





4. Remove 2 plastic grommets from top of bumper with flat bladed screw driver.

**INSIDE OF RHS CHASSIS RAIL SHOWN**

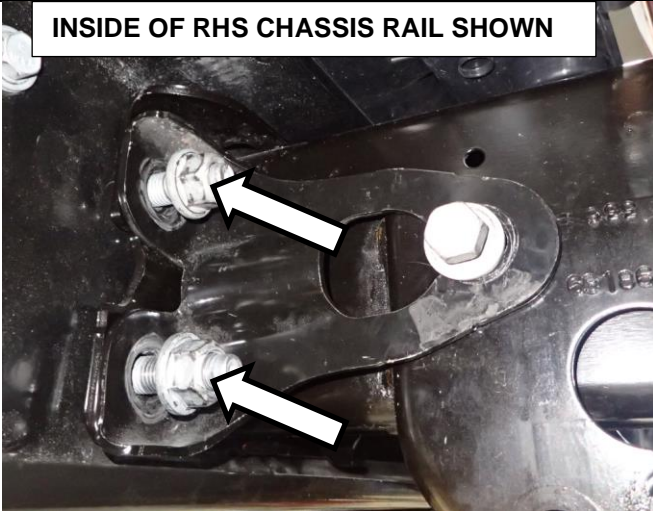

5. Undo 8 flange nuts from behind front bumper.



**OUTSIDE OF LHS CHASSIS RAIL SHOWN**



6. Remove OEM bumper from vehicle.



7. Remove screws and scrivets retaining wheel arch liners to front bumper. There are seven screws and one scrivet on each side.





8. Once the wheel arch liners have been removed and discarded, carefully remove the LED fog lights from both sides.



9. Remove all screws and scrivets retaining inner skin of bumper to outer.



10. Gently separate the inner skin from the outer, being careful not to damage parking sensor/fog light loom.



**Note: Take note of sensor orientation and position before removing, correct position and orientation needs to be maintained for relocation into ARB winch bar.**

11. Leaving parking sensors connected to loom, unclip sensors from bumper. Store loom and sensor assembly in a safe place for reuse later.



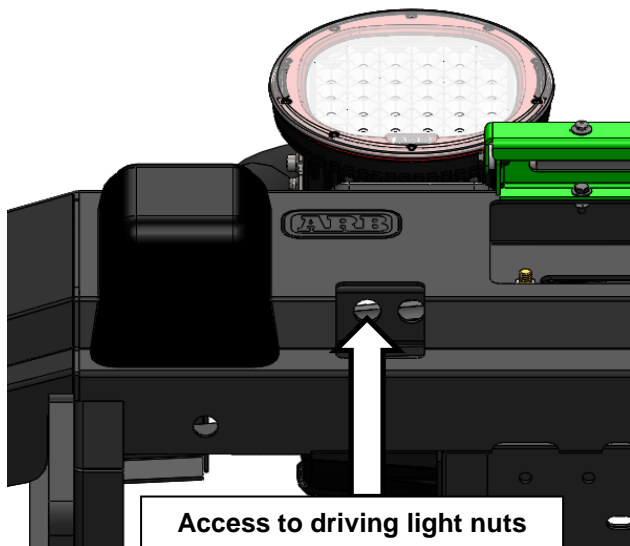

**If the vehicle is to be fitted with ARB LED driving lights, refer to step 12.**

- Position driving lights onto bull bar aligning holes in bracket with those on top surface of bull bar. Fasten driving light brackets using M8 fasteners supplied with light bracket kit. A socket extension will be required to fasten M8 nyloc nuts, accessing through the HiLift mount opening. Fasten anti-theft nut and M12 bolt using Intensity pinned socket supplied with ARB Intensity driving light kit.

 M8 - 22 Nm.

 M12 - 77 Nm.

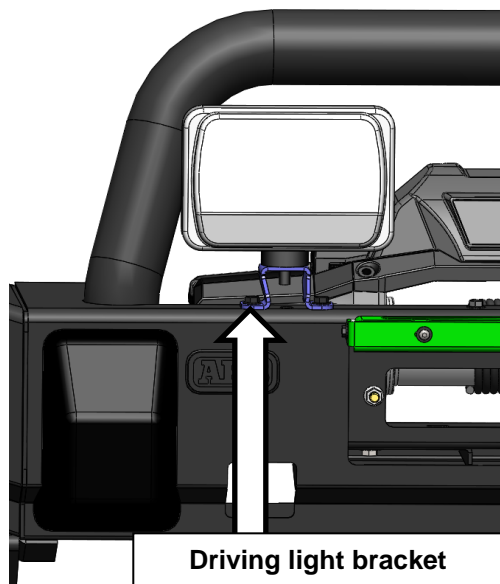

**If the vehicle is to be fitted with IPF driving lights, refer to step 13.**

- Fasten driving light brackets to bull bar using M8 fasteners supplied with light bracket kit. Fix driving lights to brackets using fasteners supplied with IPF driving light kit.

 M8 - 22 Nm.

**FOR VEHICLES NOT EQUIPPED WITH PARKING SENSORS SKIP TO STEP 17.**

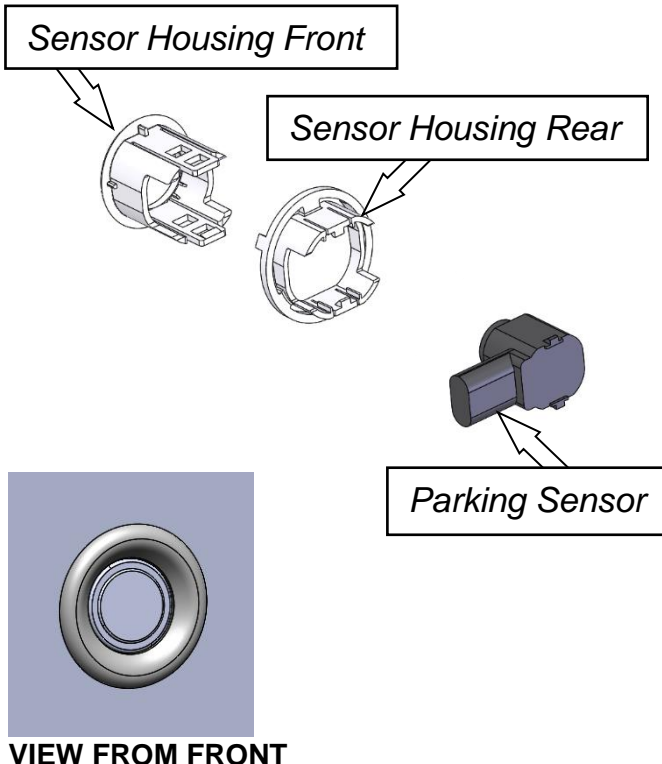

- Fit supplied ARB sensor housing front to the bull bar. Placing the housing through the bar from the front of the vehicle.
- From the rear of the bar clip the supplied ARB sensor housing rear to the front housing. Check that both clips are engaged properly. If clips don't engage apply pressure on the outer ring of the Rear Housing.
- Clip sensors into the housings. Check that both clips are engaged properly. Secure loom with cable ties supplied.

**IMPORTANT:**

**Ensure that the silicon sleeves remain on the sensors.**  
**Ensure that each sensor is central in the hole and not pressed to one side.**  
**Ensure that each sensor is installed in the correct orientation.**

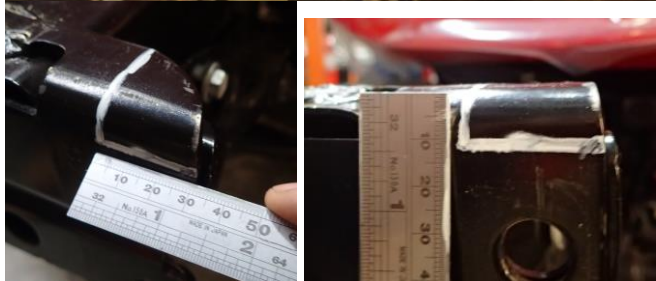
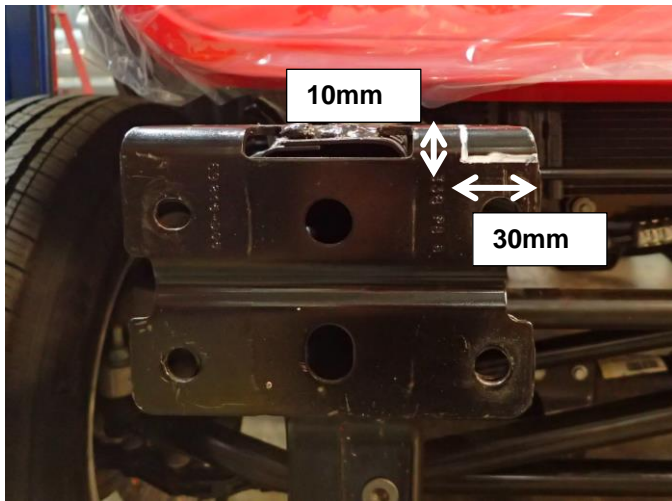

If fitting a Warn Zeon or 9.5XP winch continue to step 17, for all other winches skip to step 18 below.

17.

- A) Mark a section on the RHS chassis rail front mounting face 10mm from top edge and 30mm from inside edge. (winch motor side)
- B) Cut away marked section using an angle grinder and cutting disc
- C) Remove any sharp edges with a file.
- D) Apply black spray paint to cut edges to prevent corrosion.
- E) If fitting a Zeon winch, repeat for LHS chassis rail. (NOT REQUIRED FOR 9.5XP)



**Warning: Grinding operations can result in flying metal debris, safety glasses should be worn.**



(RHS LED)



18. Secure front of fog light to rear of mounting bracket using M4 fasteners supplied with fitting kit.

(RHS LED)

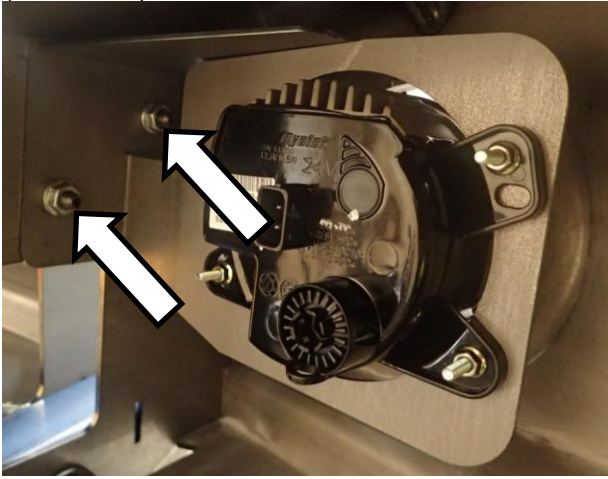

19. Secure fog light assembly to bull bar using M8 fasteners supplied with fog light fitting kit.



20. Adjust fog light so that it sits central to the fog light aperture in the bull bar. Tighten both bolts on each side of bar to torque specification.

 M8 - 22 Nm.

**Note: Final adjustment of the fog light can be carried out once the bull bar is fitted to the vehicle.**

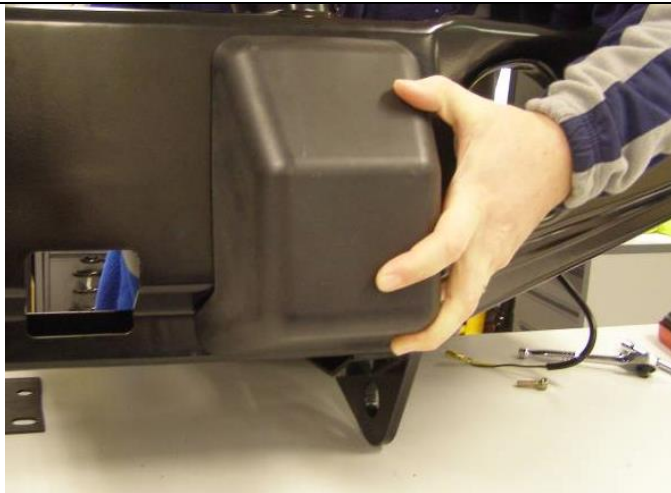

21. Position bar on a flat surface upside down so that you have access to both front and rear sections of the bull bar.

22. Fit buffers to the bar by holding each buffer against the front of the bull bar and securing from the rear using 8x 6mm trilobial screws supplied with buffer kit (4 per buffer).

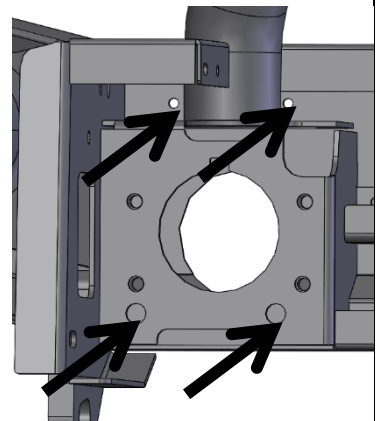

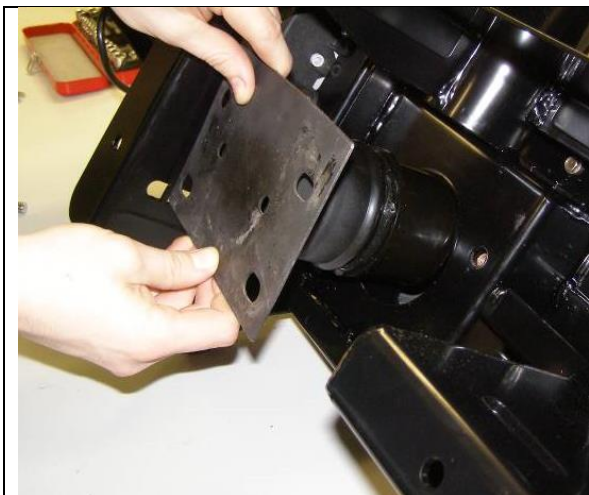

23. Position crush can impact absorbers into mounting bracket openings located at the rear of the bar.

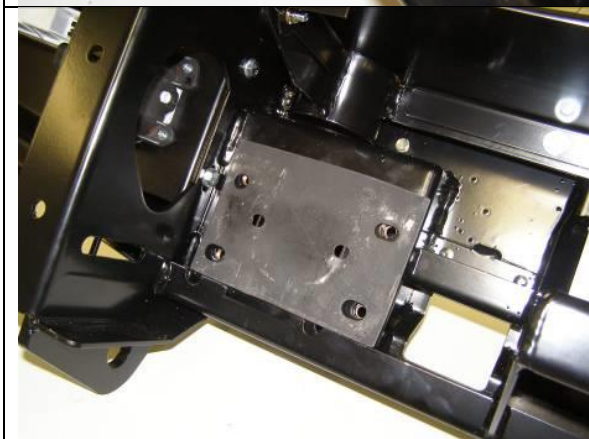

**Note:** To hold crush can / impact absorbers plate in position, smear a small amount of silicon onto mounting face.



24. With the assistance of a friend or lifting device, present the deluxe bar to the vehicle.



25. Loosely fasten bull bar to vehicle chassis using M10 sems fasteners supplied in chassis mounting kit.

**Note:** If your vehicle is not going to be fitted with a winch, install pan cover kit **ACCESSORY Part No 3550150** to bull bar before mounting bull bar to vehicle chassis.

**(Refer to Figure below)**



26. Assemble M12x82mm crush tube into lower section of chassis rail via the opening at the front.



27. Position spacer in between bull bar mounting bracket and chassis

Loosely fasten bull bar to chassis using M12 fastener sets supplied.

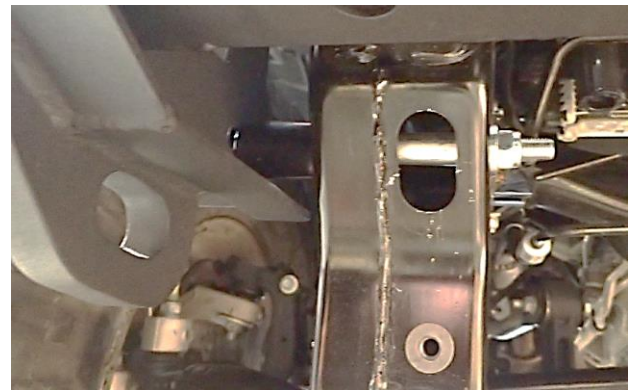
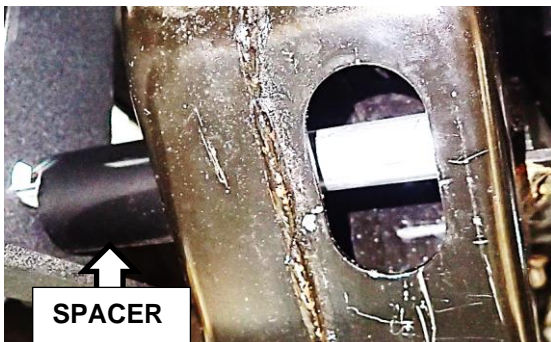

28. Tighten all chassis mounting fasteners to correct torque specification.

Tighten M10 fasteners first and then proceed to tighten M12 fasteners.

 M10 - 44 Nm.

 M12 - 77 Nm.

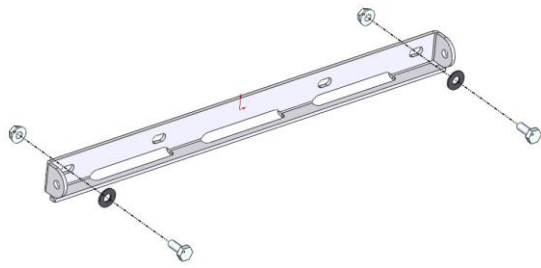

29. Fit the base bracket to the bar using 2 M6 bolts, 2 M6 flat washers and M6 flange nuts. Centralise the bracket, ensure it is level to the bar and tighten to the above specified torque.

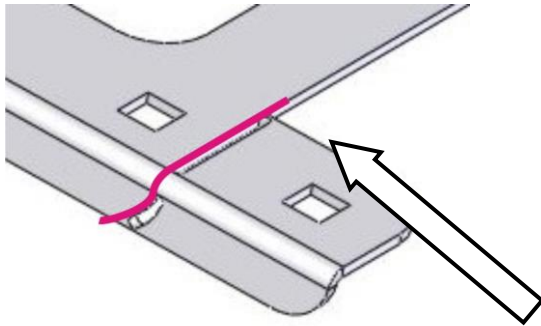

30. **For Slim line number plates**, mark cut lines on both sides of the pivot bracket as shown, using the laser cut grooves as a guide.

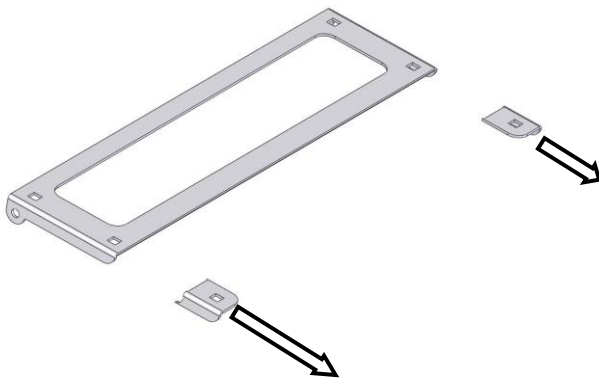

31. Use a hacksaw to carefully cut away the lower sections of the bracket and discard. Use a file to remove any sharp edges. Use matte black enamel paint to touch up the cut surfaces to prevent rust.

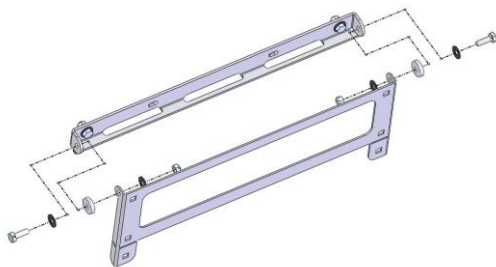

32. Fit the pivot bracket to the base bracket using 2 M6 bolts, 4 M6 flat washers, 2 M6 nyloc nuts with 2 plastic washers separating the 2 brackets as shown. Leave loose. Tighten each side evenly until the movement is firm.

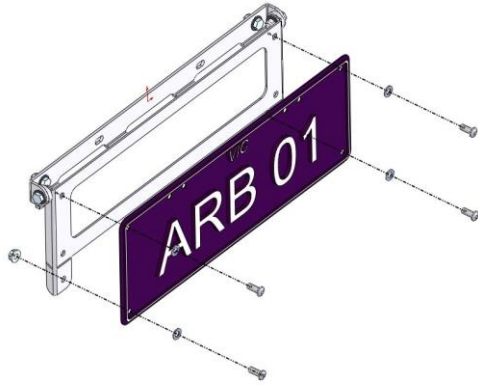

33. Using 4 SS M6 button head screws, SS M6 washers and M6 flange nuts attach the number plate to the pivot bracket.

## WINCH INSTALLATION – FITTING PROCEDURE

**\*NOT COMPATIBLE WITH WINCH ROLLER FAIR LEADS\***

34. Lower winch onto bull bar mounting platform carefully aligning with slots.  
Fit 3/8"/M10 nuts into winch retaining cavities if applicable.  
Loosely fasten winch into position from underneath the vehicle with 3/8"/M10 bolts.  
Check lateral alignment of winch relative to bull bar.

Tighten fasteners to torque specification.

 M10 - 44 Nm.

 3/8" UNC - 44 Nm.

**\*\*NOTE: DO NOT INSTALL HAWSE FAIR LEAD UNTIL AFTER DRIVING LIGHT FITMENT\*\***

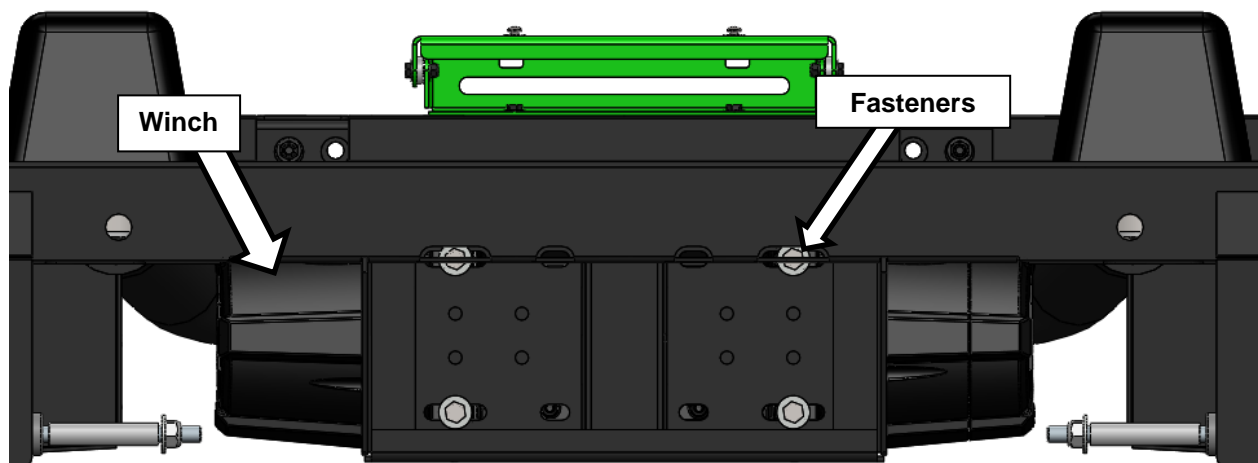

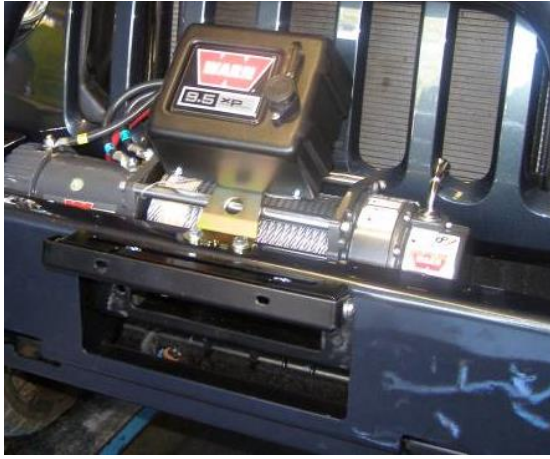

**For winch models that come with a control box to be mounted separately to the winch, complete step 35.**

35. Fit control box bracket to bar using M8 fasteners supplied with control box bracket kit. Fit control box to control box bracket using fasteners supplied with winch as per winch supplier fitting instructions.

 M8 - 22 Nm.

**Note: Use cable ties to keep power cables together and keep clear of all moving components and sharp edges.**



36. Fit the hawse fair lead to the bull bar using M10 or 3/8" fasteners supplied with winch fitment kit.

 M10 - 44 Nm.



37. Refit OEM front stone panel with original fasteners which were removed in step 2.

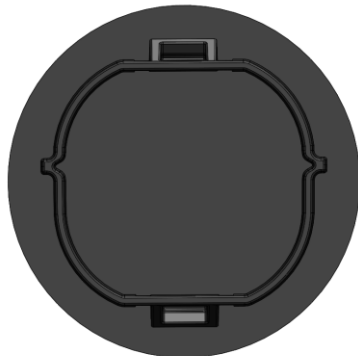

38. If vehicle is not equipped with parking sensors, install blanking plugs into sensor apertures in 6 places.

For Rubicon vehicles fitted with electronic Sway bar disconnect feature, supplementary fit kit 3550230 is required for fitment of sway bar guard. Refer to instruction number 3783611 supplied in kit.

## FITTED PRODUCT

