



# FITTING INSTRUCTIONS

Part Number: **3915200**  
Product: **SUMMIT S/BUMPER 200 SERIES (suitable for 12000lb winch)**  
Suited to vehicle/s: **TOYOTA LANDCRUISER 200 SERIES 10/2015 ON  
GX & GXL Models Only**

Optional Kits: **3500590** Fog Light Kit (LH&RH Lights)  
**3500530** AUX Fog Light Loom (non-factory fog lamp vehicles)  
**3500680** Fog Lamp Housing Clear Lens Kit  
**3500720** Winch Install Kit  
**5100300** Sahara Tube Kit LC200 MY16

## WARNING

### REGARDING VEHICLES EQUIPPED WITH SRS AIRBAG:

When installed in accordance with these instructions, the front protection bar does not affect operation of the SRS airbag.

### ALSO, NOTE THE FOLLOWING:

- This product must be installed exactly as per these instructions using only the hardware supplied.
- In the event of damage to any bull bar component, contact your nearest authorised ARB stockist. Repairs or modifications to the impact absorption system must not be attempted.
- Do not use this product for any vehicle make or model, other than those specified by ARB.
- Do not remove labels from this bull bar.
- This product or its fixing must not be modified in any way.
- The installation of this product may require the use of specialized tools and/or techniques
- It is recommended that this product is only installed by trained personnel
- These instructions are correct as at the publication date. ARB Corporation Ltd. cannot be held responsible for the impact of any changes subsequently made by the vehicle manufacturer
- During installation, it is the duty of the installer to check correct operation/clearances of all components
- Work safely at all times
- Unless otherwise instructed, tighten fasteners to specified torque

## **ARB 4x4 ACCESSORIES**

### Corporate Head Office

42-44 Garden St  
Kilsyth, Victoria  
AUSTRALIA 3137

Tel: +61 (3) 9761 6622  
Fax: +61 (3) 9761 6807

Australian enquiries  
North & South American enquiries  
Other international enquiries

sales@arb.com.au  
sales@arb.com.au  
exports@arb.com.au

**www.arb.com.au**

# GENERAL CARE AND MAINTENANCE

By choosing an ARB Bar, you have bought a product that is one of the most sought after 4WD products in the world. Your bar is a properly engineered, reliable, quality accessory that represents excellent value. To keep your bar in original condition it is important to care and maintain it following these recommendations:



- Prior to exposure to the weather your bar should be treated to a Carnauba based polish on all exposed surfaces. It is recommended that this is performed on a six monthly basis or following exposure to salt, mud, sand or other contaminants.
- As part of any Pre Trip Preparation, or on an annual basis, it is recommended that a thorough visual inspection of the bar is carried out, making sure that all bolts and other components are torqued to the correct specification. Also check that all wiring sheaths, connectors, and fittings are free of damage. Replace any components as necessary. This service can be performed by your local authorized ARB Stockist.

## FITTING REQUIREMENTS

### REQUIRED TOOLS FOR FITMENT OF PRODUCT:

Metric socket and spanner sets 8-25mm range	External Circlip pliers
Screwdrivers, Philips and Flat blade	Power Jigsaw with blade for plastic cutting
Short Body Power Drill 13mm (1/2") capacity	Dia 7.0mm (5/16") and 10.5mm (25/64") drill bits
Torque Wrench (9-102Nm)	Marking pen
Half round file	Soft Hammer
Metric hex&torx key set	Loctite© 262 or equiv.
Wide masking tape	Stanley knife and Multitool
Small Spirit Level	Tape Measure & 2 x 300mm rulers
Right-angled Drill	Paint black fast drying

### HAVE AVAILABLE THESE SAFETY ITEMS WHEN FITTING PRODUCT:

Protective eyewear 	Hearing protection 
--	--

**NOTE: 'WARNING' notes in the fitting procedure relate to OHS situations, where to avoid a potentially hazardous situation it is suggested that protective safety gear be worn or a safe work procedure be employed. If these notes and warnings are not heeded, injury may result.**

### FASTENER TORQUE SETTINGS:

SIZE	Torque Nm	Torque lbft
M6	9Nm	7lbft
M8	22Nm	16lbft
M10	44Nm	32lbft
M12	77Nm	57lbft

<b>PARTS LISTING</b>			
<b>APPLICATION.</b>	<b>PART NO.</b>	<b>QTY</b>	<b>DESCRIPTION</b>
<b>Mount Brackets To Chassis</b>	3759917R	1	Bracket Mount RHS
	3759917L	1	Bracket Mount LHS
	6151428	2	Flange Nut M12 x 1.75
	6151429	2	Chassis Stud M12 x 265 x 1.75
	6151435	2	Nut Clevis
	5846400	2	Packer M12 x 8mm
<b>Brace Assembly</b>	4681274	1	Brace
	6151357	15	SEMS Bolt M10 x 1.5 x 30mm
	6151321	15	Nut Flanged M10 x 1.5
	3759770R	1	Brkt Wing Brace RHS LC200 15ON
	3759770L	1	Brkt Wing Brace LHS LC200 15ON
<b>Bull Bar To Mount Bracket Assy</b>	6151357	4	SEMS Bolt M10 x 1.5 x 30mm
	6151321	4	Nut Flanged M10 x 1.5
	6151360	6	Bolt M12 x 1.75 x 35mm
	6151428	6	Flange Nut M12 x 1.75
	4581049	6	Washer Flat M12
	4581064	6	Washer Spring M12 tzp480
<b>Stone Tray to Bull Bar</b>	6522683	1	Stone Tray
	6151300	4	Nut Cage M6
	6151711	4	Screw BTN HD TX M6 x 25 BTZP480
	4581082	6	Washer Flat M6 x 16 x 3
	4581287	6	Washer Spring M6
	6151270	2	Bolt M6 x 40
	4721518	2	Spacer Tube 18mm
<b>Fit Lights and Mouldings</b>	3500880	1	Grille Split Pan Kit
	5100200	1	Buff Kit 2pce Front Section Kit
	6821287	1	Lamp Led Indicator Clearance Kit
	3163082	1	Surround ARB Foglight Kit
	6821116	4	Grommet Nylon Snap In Type
<b>Number Plate To Bull Bar</b>	6821189	2	Grommet round
	6151384	2	Screw self tapping pan head
	6151213	3	Bolt M6 x 1.0 x 20mm Gd 8.8 Bz
	3759488	1	Bracket Lic Plate Fixed Large Rad
	4581287	3	Washer Spring M6 x 2.5 x 1.6 Bz
	4584295	3	Washer Flat M6 x 12 x 1.3 Bz
	6151128	3	Nut Flange M6 x 1.0 ZP
<b>Wing Inner Panels</b>	6523075R	1	Panel Wing LC200 RH
	6523075L	1	Panel Wing LC200 LH
	6151315	10	Nut Caged M6
	6151711	10	Screw BTN HD TX M6 x 25 BTZP480
	4581082	10	Washer Flat M6 Blk
	4581287	10	Washer Spring M6 Blk
	3759754	2	Brkt Wing Panel LC200
	6151546	4	Bolt M8x1.25x20
	4581075	4	Washer Flat M8
	4581047	4	Washer Spring M8
	6151132	4	Nut M8 Flanged
<b>Fit Winch Cover Panel</b>	6522985	1	Panel Press Form Cover LC200
	6151213	4	Bolt M6 x 1.0 x 20 Gd8.8 BZ
	4581287	4	Washer Spring M6 x 2.5 x 1.6 BLK ZN
	4584295	4	Washer Flat M6 X 13 X 1.6 BLK ZN
	6151128	4	Nut Flange M6 x 1.0 ZP
<b>Miscellaneous</b>	6191030	2	Trim Pinch Weld 520mm
	6191029	2	Trim Pinch Weld 140mm
	3789459	1	Template Bumper Cutting
	180302	6	Cable ties

## REMOVAL OF BUMPER



1. Remove number plate



2. Remove inner guard bumper retaining screws three per side using T30 Torx key.



3. Remove lower trim panel sets each side which attach to bumper and engine protective plate area then set aside, they will not be reused.



4. When removing lower trim panels, a plastic nut located on each side will need to be prized open with a small flat blade screwdriver to assist removal.



5. Remove lower bumper retaining screws.



6. Remove plastic engine bay cover above grille area and set aside. Press down on centre of plastic plugs with small screwdriver or similar to release.



7. Remove retaining screws from top of grille
8. Lift upper RH and LH grill corners to release from upper clips

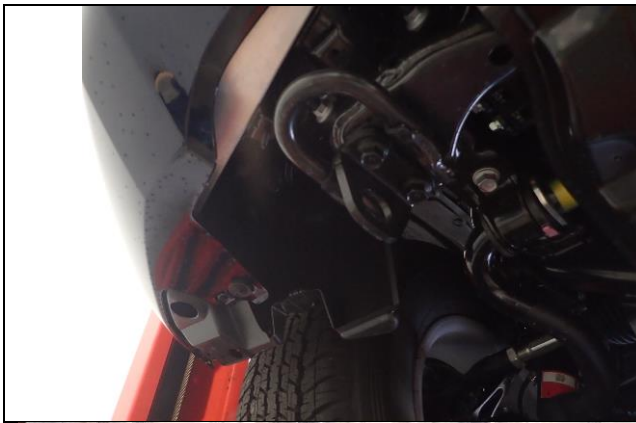

9. Remove right and left splash guards located at the recovery hooks.



10. Apply wide masking tape along bumper as shown, then having cut out template, apply to outer corner of RHS bumper as shown. Align with edge of quarter panel, wheel arch and underside of headlight.

**NOTE: There is a scale on the sheet to confirm that the template is 1:1 scale, this is critical.**

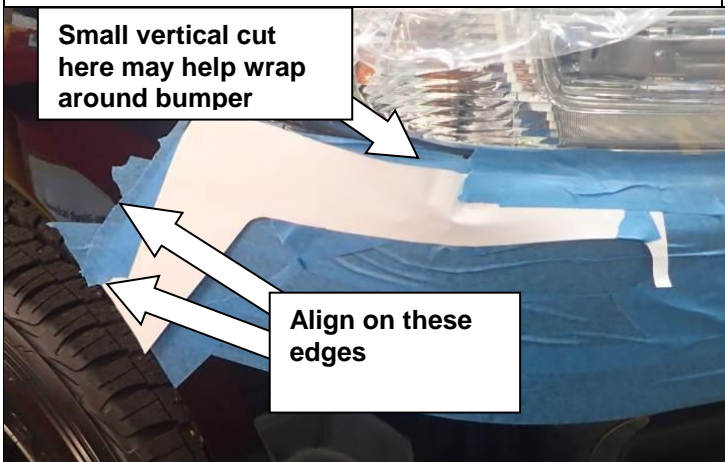

11. Ensure template is correctly positioned along the edge of the bumper both at the front quarter panel as well as along the wheel arch. Mark along cut edge with a marker.

**NOTE: Be careful not to damage template as it must be reused for LHS.**



12. Reverse Template and repeat for LHS.  
(RHS SHOWN)



13. From where the template finishes, mark a line diagonally down, running 40mm down and 50mm across towards the centre of the vehicle as shown in picture.
14. With a ruler mark a straight line along the bumper from the end of the diagonal line to the corner vertex.
15. Finally, continue the line around the bumper radius as shown.

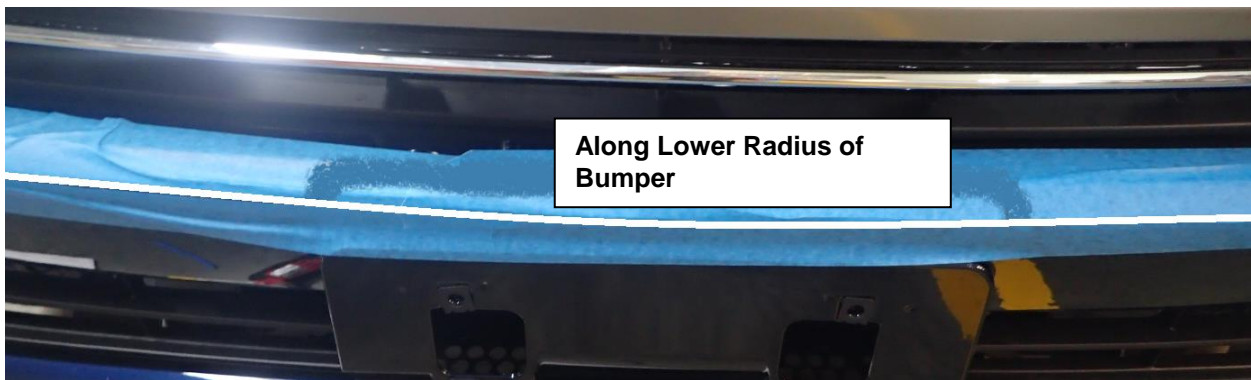

16. Repeat for LHS.
17. **If Fitting Warn Magnum Control box**, a further 25mm thick cut is required, mark out directly above the moulding for number plate; do not cut past upper radius.

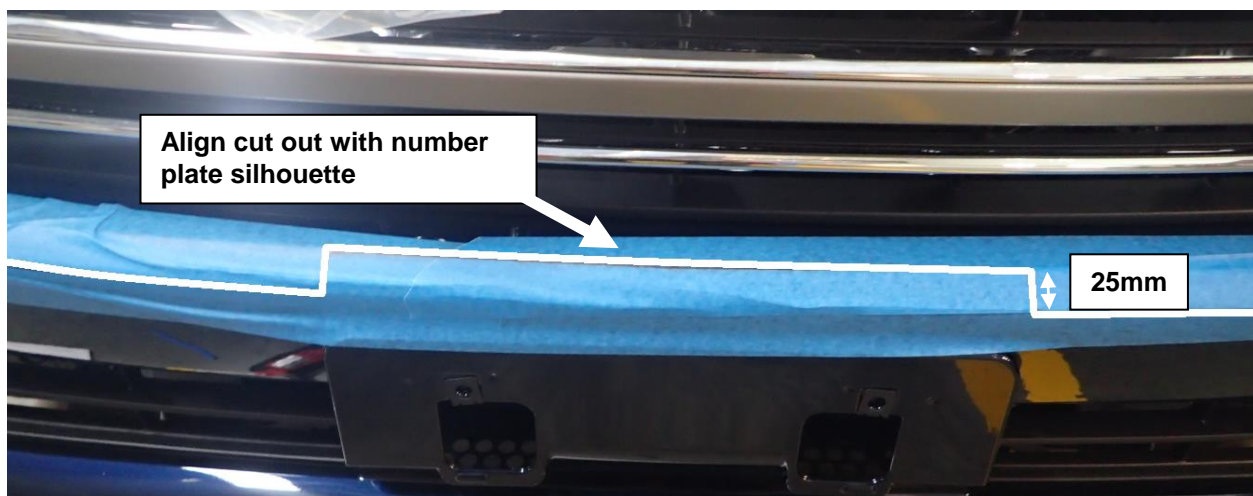



18. Gently remove chrome pieces below headlight by pulling off by hand. (Both Sides)

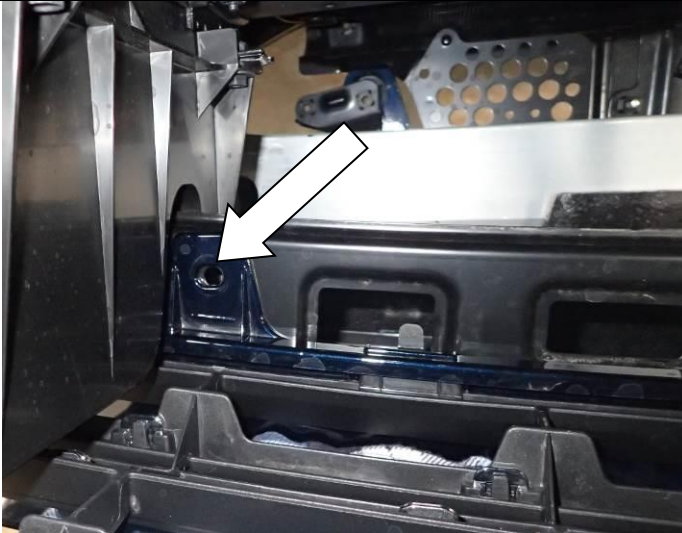

19. Remove plastic plugs securing upper bumper tabs to cross member.
20. **NOTE: As bumper is being removed, check that all wiring looms and washer lines are disconnected.**



21. You can now remove the bumper and grille and place on soft nonabrasive rug or similar, it is best to do this with the help of another person

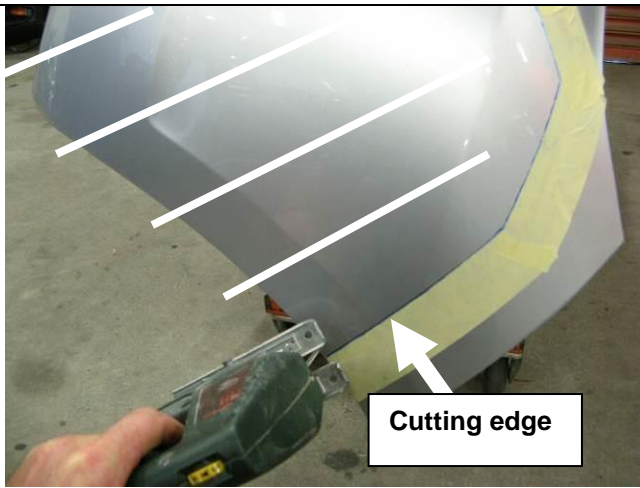

22. Place bumper face up on a bench or similar so there is sufficient access for the cutting operation
23. Using a jigsaw or multi-tool carefully cut along the marked edge of the masking tape.
24. Remove burrs from the cut edge of the bumper, and then set aside on a soft nonabrasive surface.

**Warning: Cutting operations can result in flying debris, safety glasses should be worn. Work safely; keep fingers clear of cutting blade.**

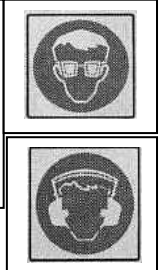

25. Remove foam absorber bar and set aside, this will not be reused
26. Remove crash beam with mount brackets and set aside, retain only M10 flange nuts for reuse.



27. Remove tow hooks and set aside, these will be reused.



28. Mark the lower section of the air scoop for the power steering radiator as shown. This is for trimming to clear the mount brackets.

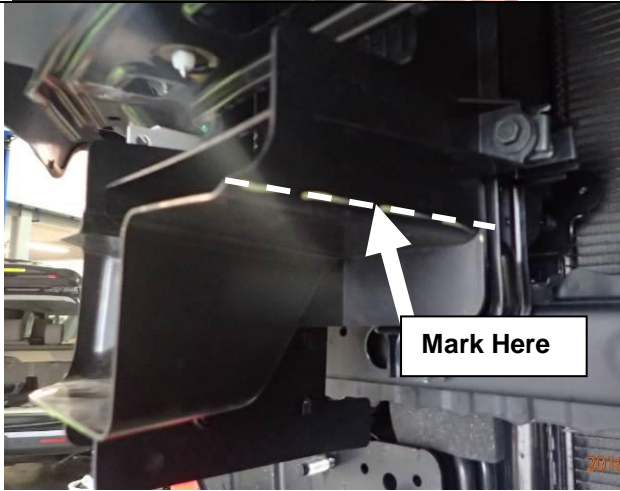

29. Now mark along the lower bend as shown, now cut the shroud along the marked edges as shown

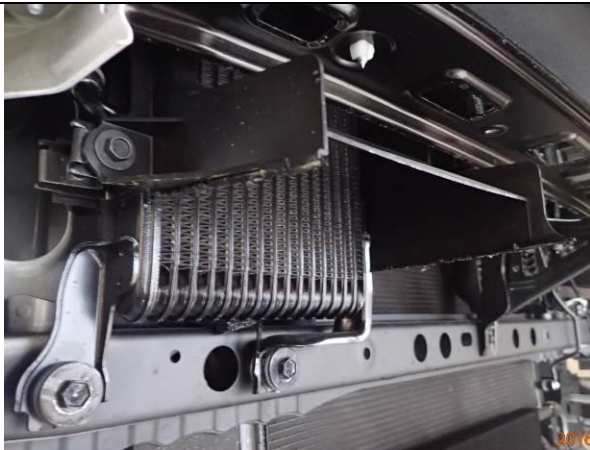

30. Once the cut is complete it should look as displayed.

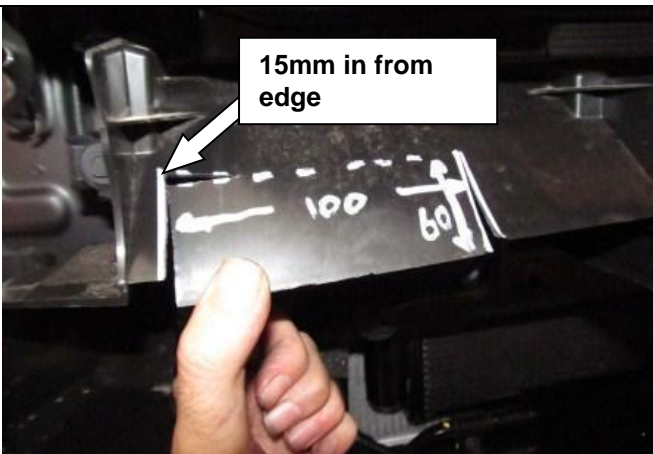

31. Now on the upper face of the power steering shroud mark and cut as shown

*Hint: You can do this on the vehicle as shown.*

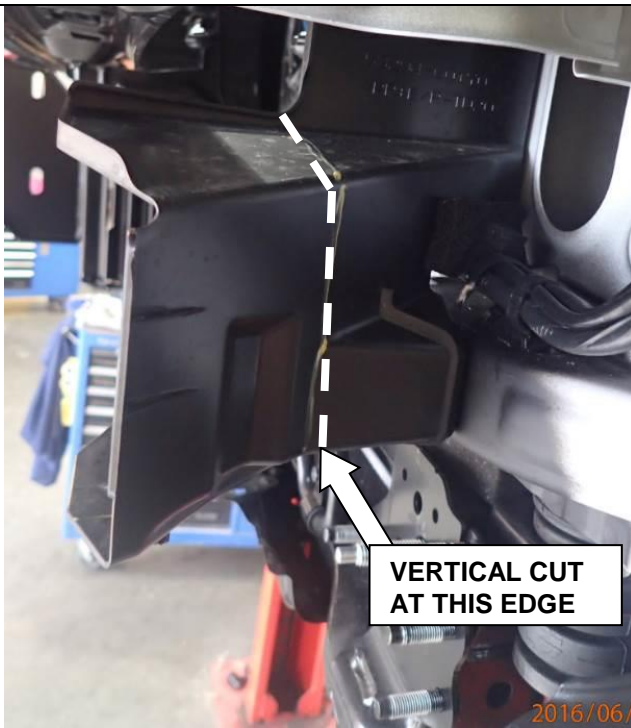

32. Mark out a vertical cut line on the LHS air deflector.

*Hint: You can do this on the vehicle as shown.*

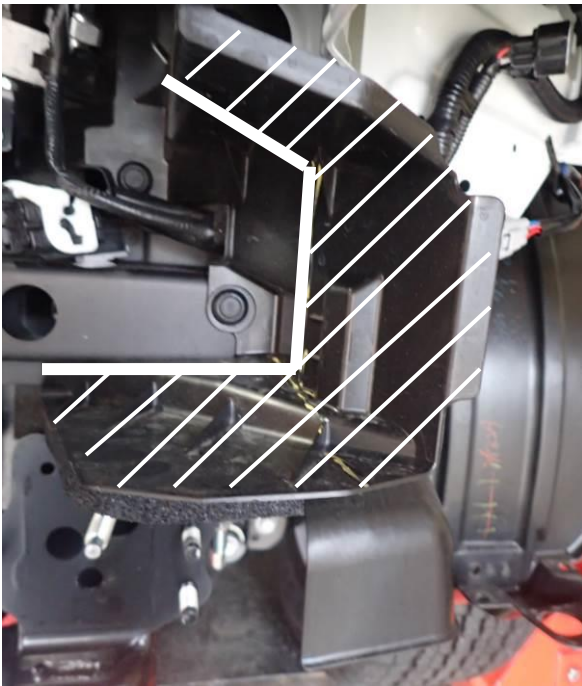

33. Mark out a second line to meet up with the line in the previous step. Cut the air deflector on the LHS of the vehicle using a multi tool or similar. Shaded area shown must be removed.

*Hint: You can do this on the vehicle as shown.*

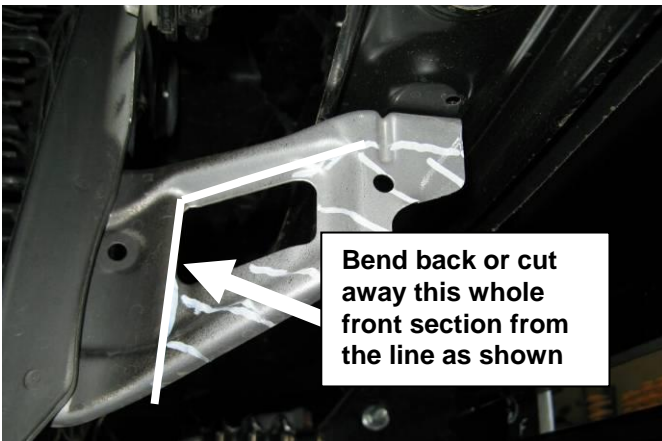

**IF fitting Bushranger DV-12TH 12000lb winch ONLY**

34. Undo bolt securing the brace attached to the centre of grille cross member. Relieve or bend back the forward section of the vehicle sheet metal member as shown to clear winch tie rod.



35. Fit the cut bumper and grille and secure. as shown
36. Secure the wing return in the wheel arch area with one of the original dome head screws each side.

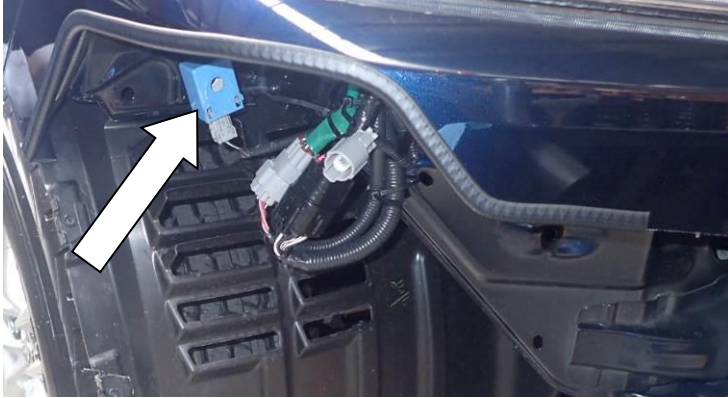

37. Fit pinch weld to each end of the bumper as shown.
38. By shielding surrounding areas first, spray paint the blue electrical module black.
39. Gently replace chrome pieces (removed in step 18) below headlight by pushing on by hand (both sides).

## FITTING PROCEDURE

**Note: If fitting a winch proceed from here using fitting instructions 3789337 supplied with 3500720 winch install kit. Once the winch is fitted please continue to step 43. If no winch is being fitted continue from here.**

40. Slide the winch cover panel from the bottom up until it is level with the top face of the bar.
41. Fit the winch cover panel to the bar using 4 x M6 x 20 hex bolts, spring washers, flat washers and flange nuts.

**Warning: Be careful not to scratch the finish of the winch cover panel.**

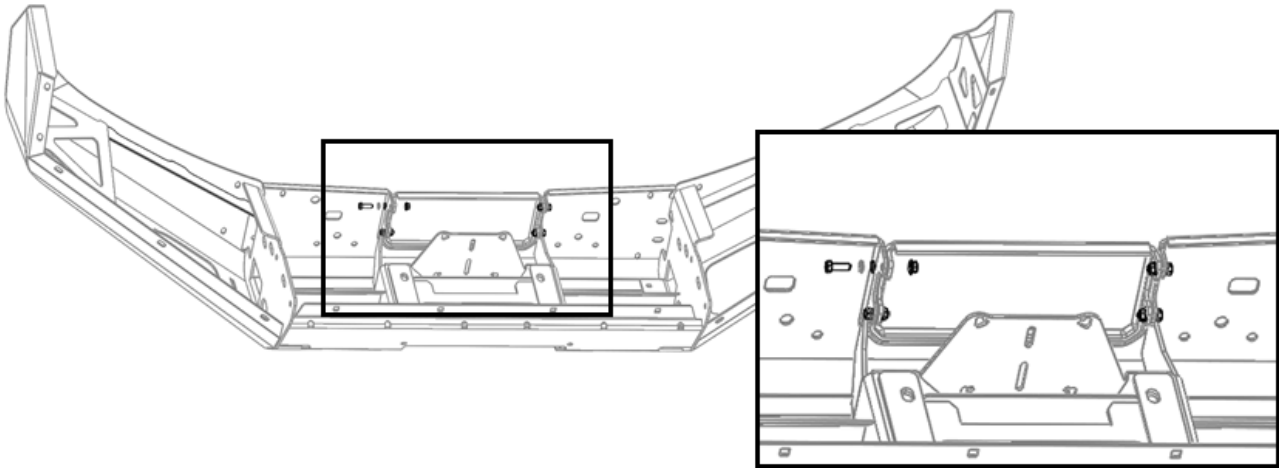

Generic image. Bull Bar shown may not be representative of actual product.

42. Fit the number plate bracket to the top face of the lower-centre pan on the bar using 3 x M6 x 20 hex bolts, spring washers, flat washers and flange nuts.

**Note: If you are fitting a winch, fit the folding number plate bracket supplied in winch install kit "3500720 WINCH INSTALL KIT" – See fitting instructions 3789337**

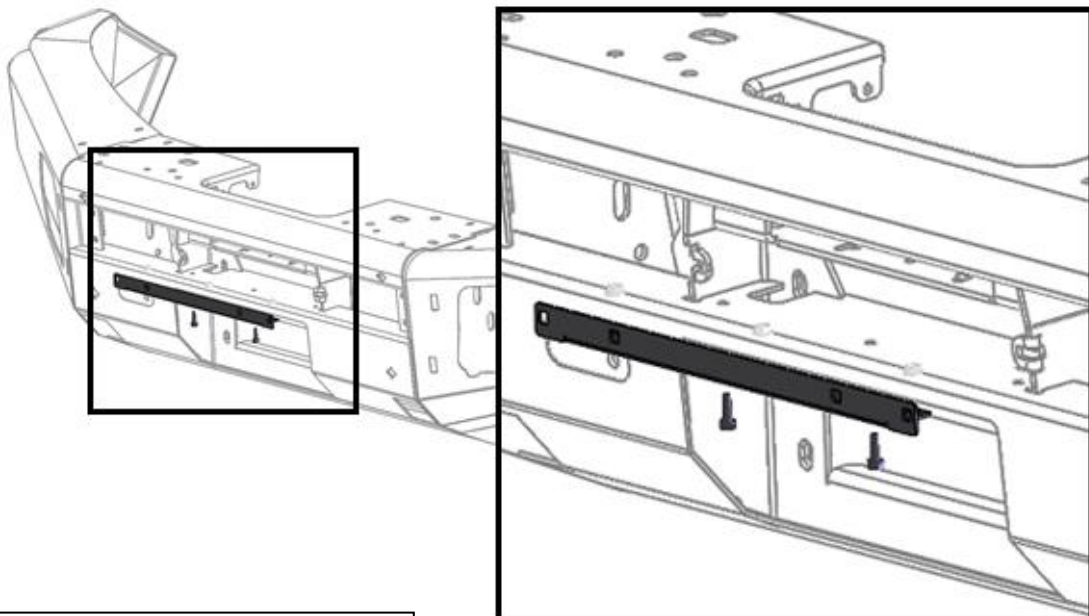

Generic image. Bull Bar shown may not be representative of actual product.

**Note: The following steps show the fitment of the plastic moulded parts. The mouldings are supplied in kits along with all fasteners required for fitment. It is important that the fasteners supplied with each kit are only used for the mouldings from the same kit.**

**The kits included in this bar kit are as follows:**

43. Layout the contents of each of the following kits ensuring the contents are kept separate from each other.

Kit No.	Description
5100200	BUFF KIT 2PCE FRONT SECTION
3500880	SPLIT PAN MESH KIT
3163082	FOG SURROUND KIT

Buffer Kit – (Installation Dependent)	
Kit No.	Description
5100220	BUFF KIT 2PCE REAR SAHARA TUBE
5100230	BUFF KIT 2PCE REAR SAHARA BMPR

44. Mark the grille panel to be cut at the 910mm marks at each end on the back face.

**Note: When marked, double check the measurement with a measuring tool.**

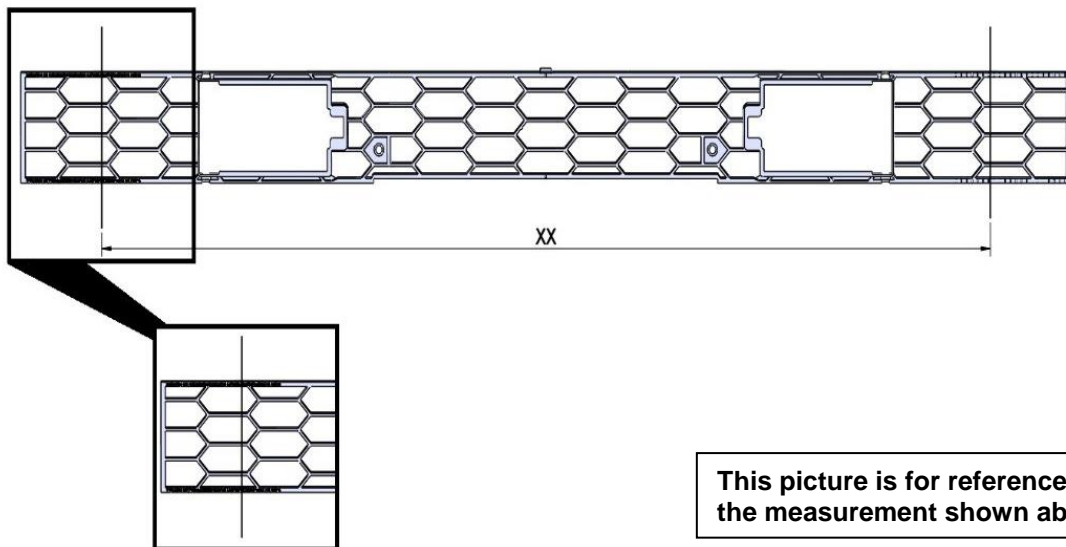

45. Use a hacksaw or similar cutting tool to carefully cut the grille panel at the positions marked in the step above.

46. Discard the off cuts and clean up the cut edges using a file or sandpaper.

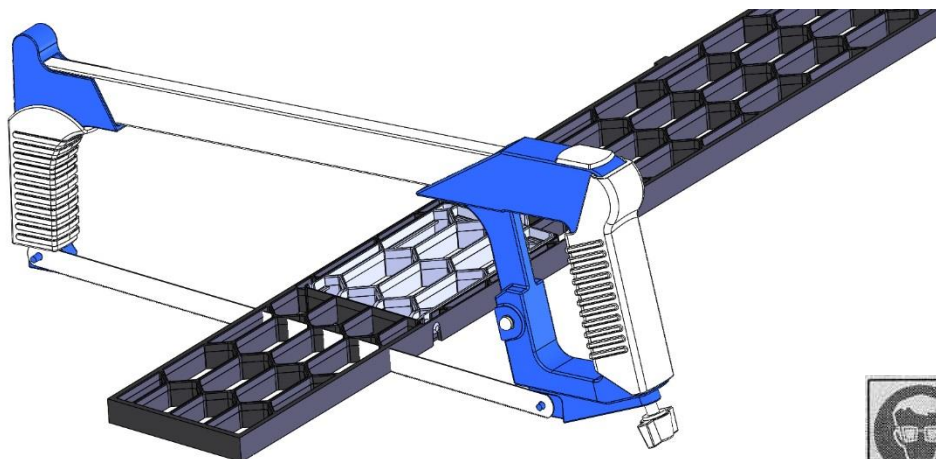

47. Insert the 6 x plastic grommets into the 6 square holes in the front face of the bar.
48. Insert the grille into the bar so that the hatches open outward (facing the front of the bar).
49. Attach the grille to the centre of the bar using the short screws into the grommets fitted above.
50. Attach the ends of the grille to the bar using the longer screws, through the clamp plates into the remaining grommets.

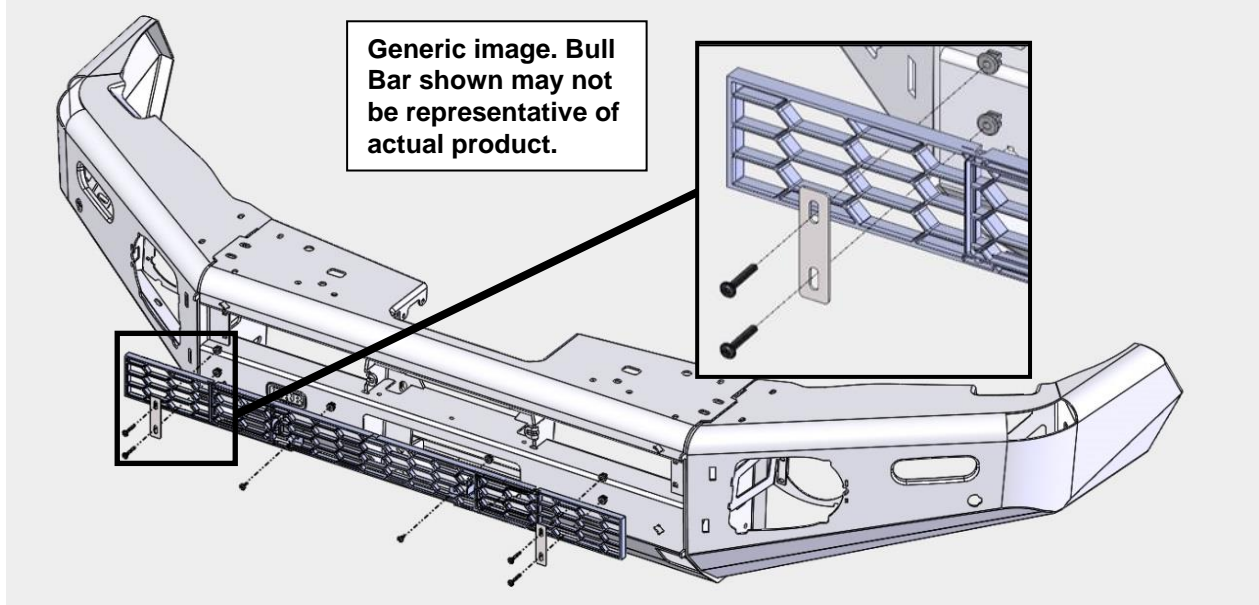

51. Place each of the front buffer sections onto the bar as shown. Ensure that the 2 lugs and 2 screw bosses pass through the holes in the bar.

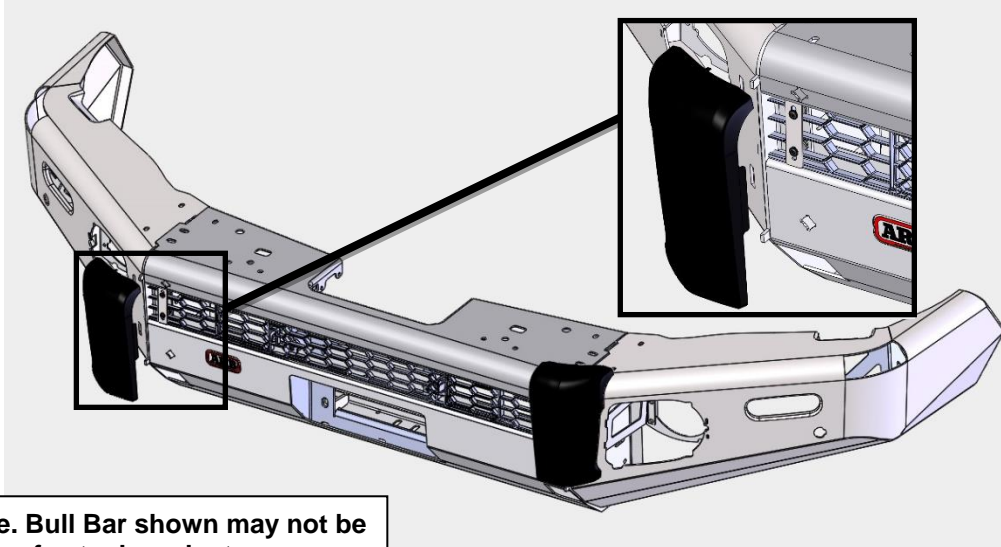

Generic image. Bull Bar shown may not be representative of actual product.

52. Ensure each buffer sits flat against the face of bar. Secure wing side using retaining clips. Secure inner side using the angled cup washers, flat washers and screws.

**The widest point of the cup washers goes to the top of the bar.**

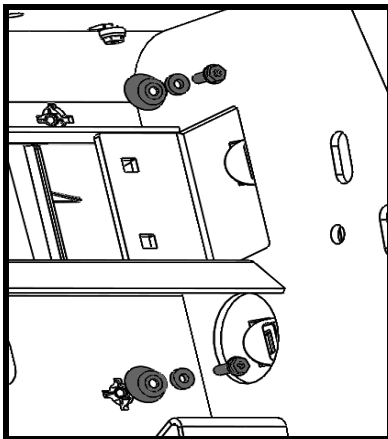

Fit washers under screw heads.

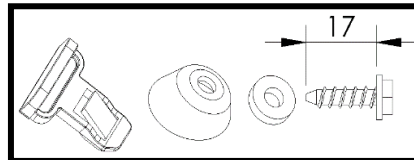

Generic image. Bull Bar shown may not be representative of actual product.

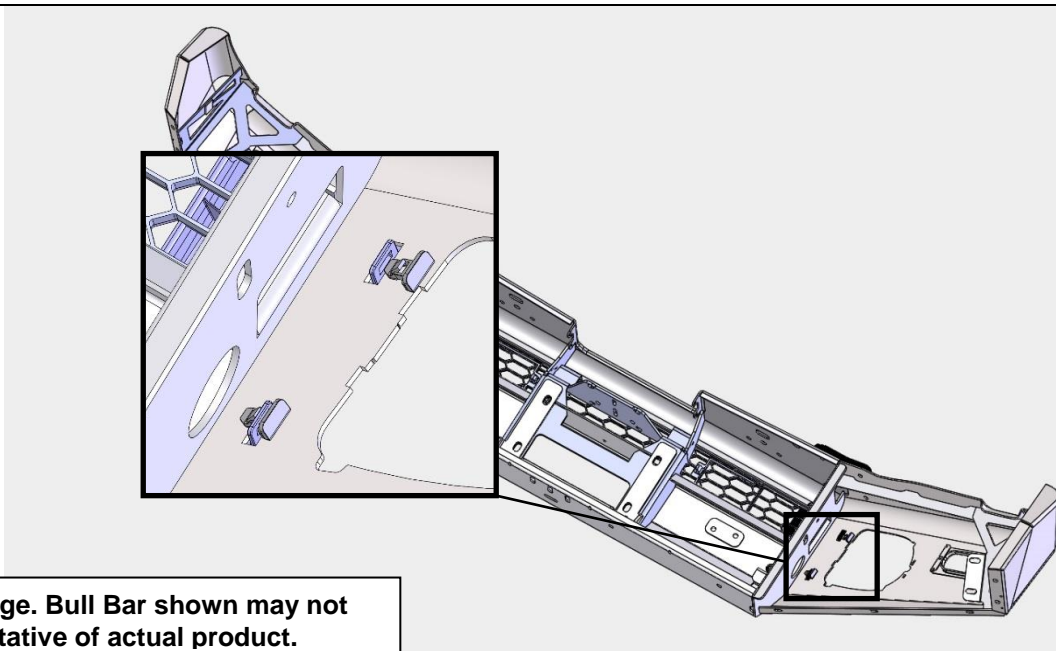

Generic image. Bull Bar shown may not be representative of actual product.

## FITTING PROCEDURE – SAHARA BUMPER

**Note: If installing in Sahara Bumper configuration proceed from here using Buffer Kit 5100230. If installing in Sahara Bar configuration (with top tube installed) please continue to step 54.**

53. From the rear of the bar, slide the rear buffer sections into the front sections as shown. Ensure the tongue section on both sides of each buffer engages into the slots of the front sections. Fit 4 x screws and washers. Tighten screws once correct fitment is achieved.

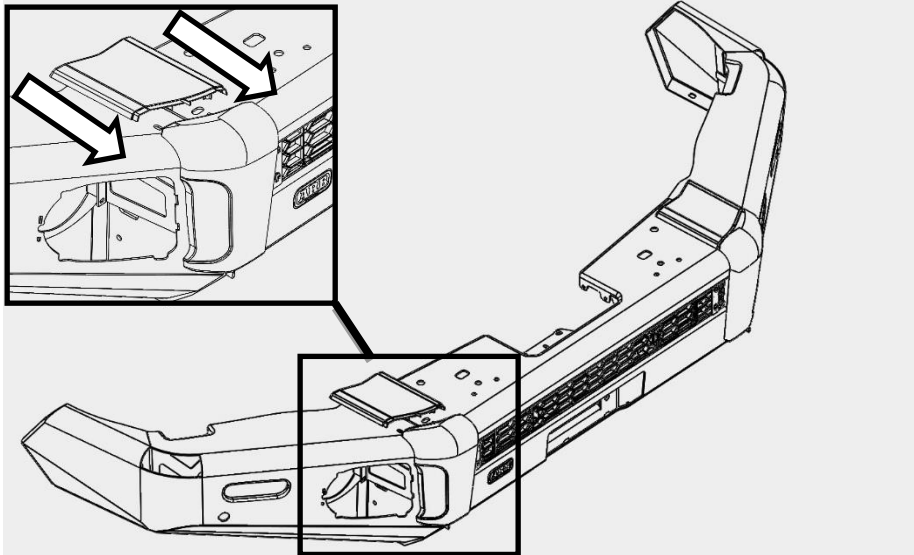

Fit washers under screw heads.

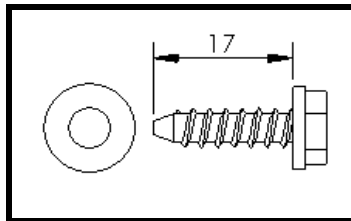

Generic image. Bull Bar shown may not be representative of actual product.

## FITTING PROCEDURE – SAHARA BAR

**Note: If installing in Sahara Bar configuration (with top tube installed) proceed from here using 5100300 - Sahara Tube Kit, (Buffer Kit 5100220).**

54. From the rear of the bar, slide the rear buffer sections into the front sections as shown. Ensure the tongue section on both sides of each buffer engages into the slots of the front sections. Fit 4 x screws and washers. Do Not Fully Tighten.

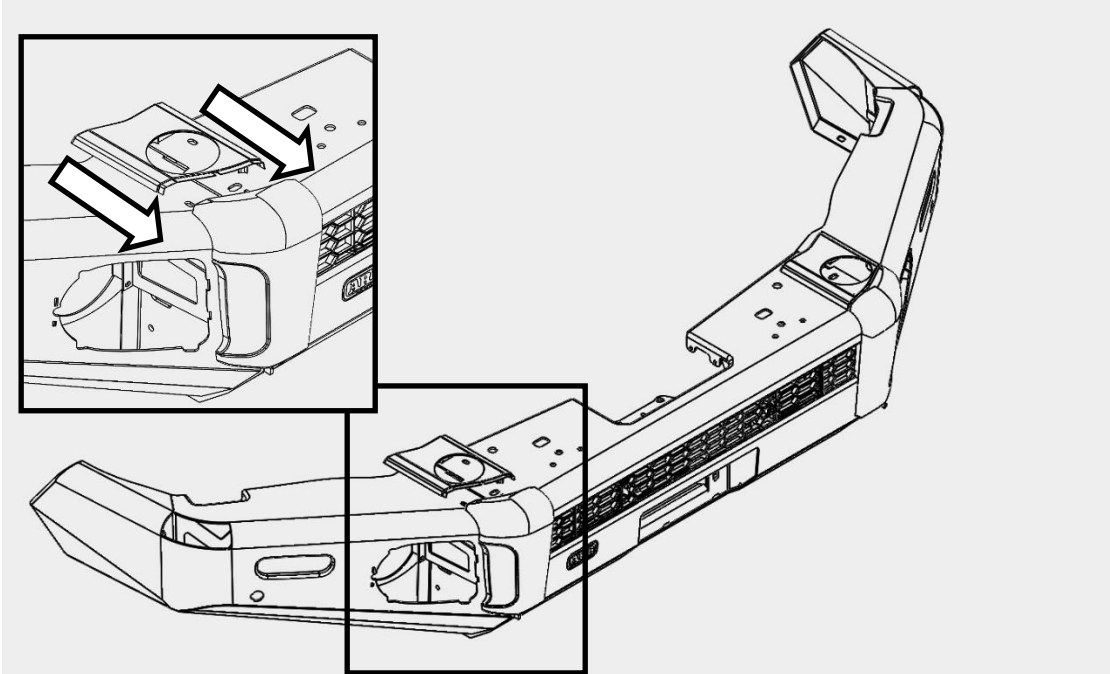

**Fit washers under screw heads.**

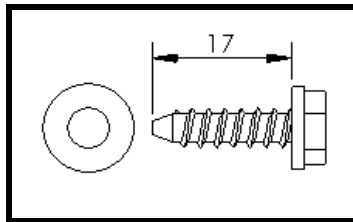

**Generic image. Bull Bar shown may not be representative of actual product.**

55. Insert Top Frame into the rear buffer holes.

Generic image. Bull Bar shown may not be representative of actual product.

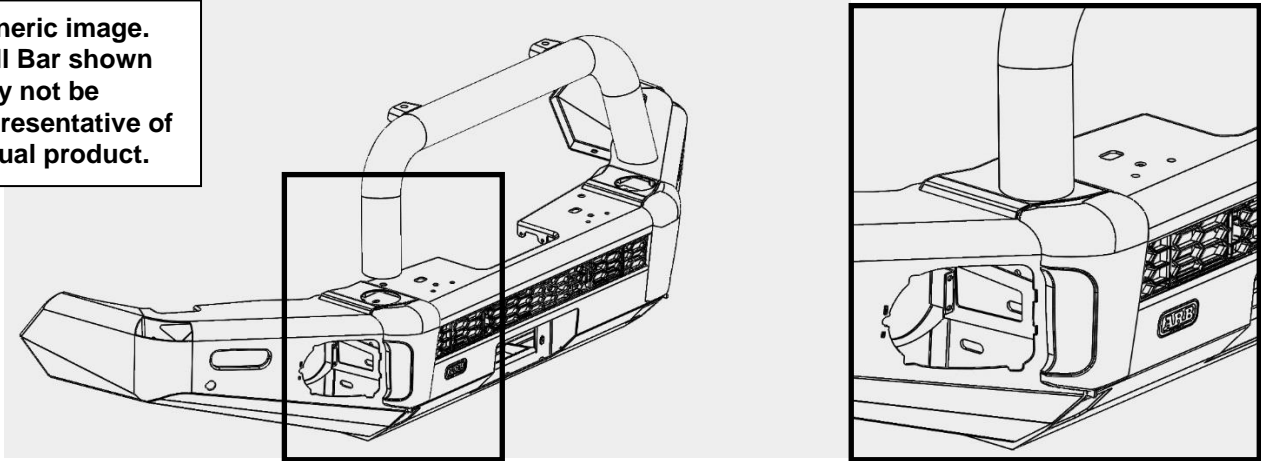

56. Fasten top tube to the bar using 4 x M10 SEMS Bolts. Adjust position of top tube left/right until it sits central on the bar and the rear buffers are positioned correctly. Tighten M10 SEMS Bolts to specification. Tighten Rear buffer screws.

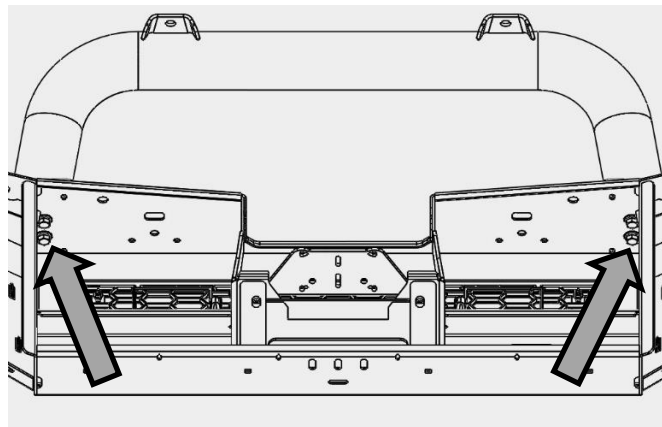

Generic image. Bull Bar shown may not be representative of actual product.



M10 SEMS - 22Nm - **Do not over tighten**

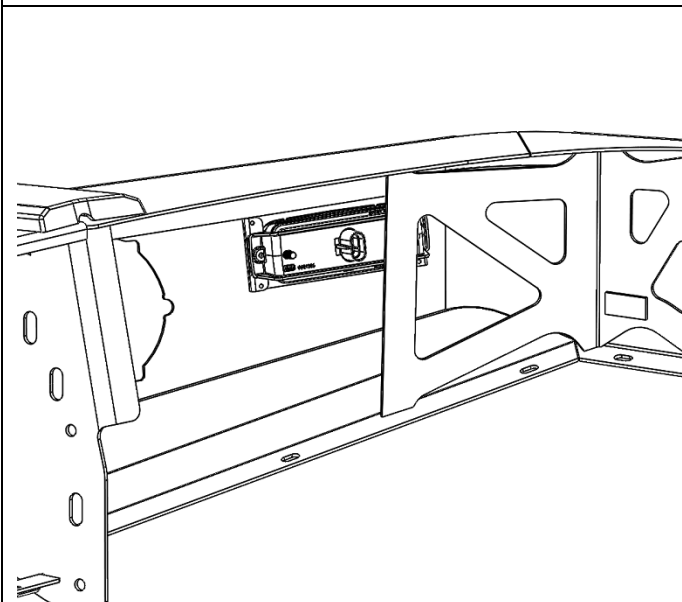

57. Fit the small plastic grommets to the bar and attach the combination LED lamps to the bar using the screws provided with the lamp kit.

**Caution: Correct orientation of indicator is achieved by ensuring the arrows on the lamp are pointing to the outside of the vehicle.**

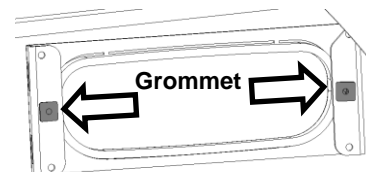



58. Insert clevis nut into rectangular hole in the inboard face of chassis, ensuring the threaded end is inserted first.

The nut when fitted correctly should fit square and locate into the chassis rail.

**NOTE: Take care not to drop clevis nut into the chassis.**



59. Install the chassis stud by fitting 2 nuts to the end of the stud and tightening until thread bottoms out.

60. Remove nuts and repeat for the LHS.



61. Loosely fit the mounting brackets to the chassis securing with the 8mm packers and flange nuts.

62. Secure using existing OE M10 flange nuts, **but do not do up tight.**

63. Refit Tow hooks below mounting brackets with OE fasteners removed in step 26, **but do not do up tight.**

**NOTE: DO NOT DO UP TIGHT**



64. Tap the outer flange of the mount brackets until they are hard up against the tow hook mount area. Nip up the lowest outboard nut on each bracket. Brackets should be less than 935mm apart.



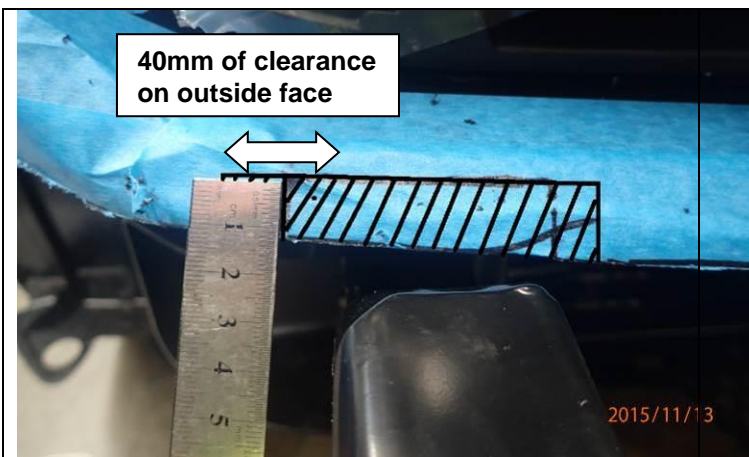

65. The Mounting brackets will contact the bumper, mark a rectangular cut on the bumper to ensure that there is a minimum of 25mm of clearance between the mounting bracket and the bumper. 40mm clearance is required on the outside face of the mount. Remove shaded area of bumper.



66. Fit pinch weld to the cut edge of the bumper as shown.

## CONNECTING LED INDICATOR/CLEARANCE LIGHTS (DRIVER'S SIDE)



### DRIVERS SIDE:

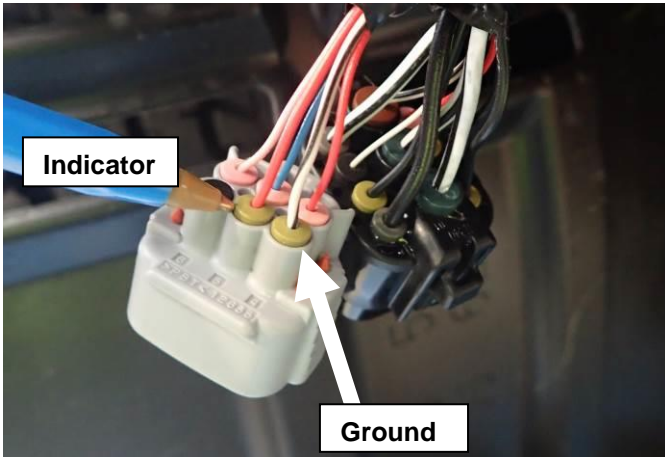

67. On the Driver's side Remove OE wiring loom bracket as shown with Phillips head screw driver. Detach plugs from bracket and discard bracket, it will not be reused.  
Unplug both the black and grey plugs from their sockets.

68. Using supplied scotch locks for the electrical connections connect the LED Indicator/clearance light looms as per table below:

LED INDICATOR/CLEARANCE LOOM	
Cable Colour	Function
RED	CLEARANCE (+)
GREEN	INDICATOR (+)
BLACK	GROUND (-)

69. On the Grey Socket, the red wire is the indicator signal; white wire with black stripe is the ground. On the Black Socket the black wire shown is the clearance signal.



## CONNECTING LED INDICATOR/CLEARANCE (PASSENGER SIDE)

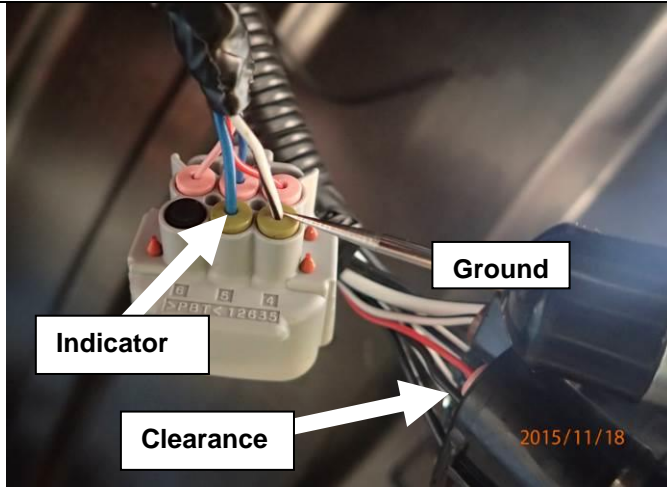

70. As done on Drivers Side, remove and discard OE loom bracket. Split grey plug and socket as shown adjacent.
71. Using supplied scotch locks, connect LED light loom as per table in step 67. Blue wire shown is the indicator signal; white wire with black stripe is the ground. On the black socket, the black wire shown is the clearance signal.

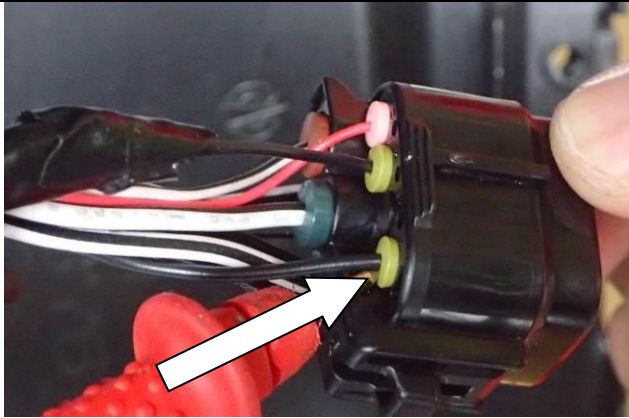

72. If installing driving lights, the high beam signal can be tapped into on the passenger side of the vehicle using the black wire on the black plug shown.

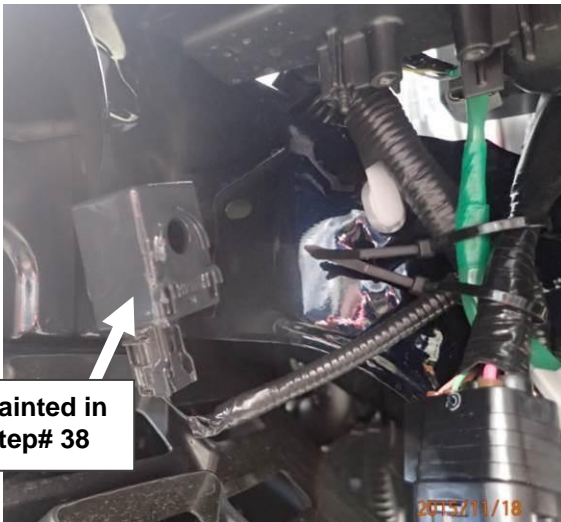

73. Once satisfied that sturdy electrical connections have been made on both sides, cable tie both harnesses back onto the sheet metal underneath the headlights as shown.

## FITTING BULL BAR TO VEHICLE



74. Ensure all other aftermarket accessories such as driving lights/winch/UHF aerial have been fitted to the bull bar.

**NOTE: Winch Roller Fairlead must be drilled to 25mm offset if not already done so.**

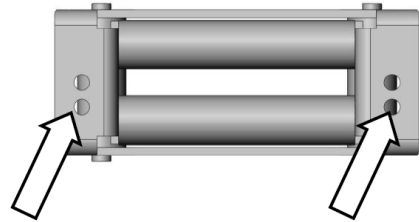

75. With the aid of a lift table or one or more assistants carefully and safely lift then position and loosely bolt the bull bar to the mounts using 6 x M12 bolts, large flat washers, spring washers and M12 flange nuts. Centralise the bar to the front of the vehicle.

**NOTE: DO NOT DO UP TIGHT**



76. Loosely fit the cross brace to underside of lower pan and on top of gussets of mount brackets. Use M10 x 30mm SEMS bolt and flange nuts.

**NOTE: DO NOT DO UP TIGHT**



77. Loosely fit both left and right wing braces to inside of wings and mount brackets. Use M10 x 30mm SEMS bolt and flange nuts.



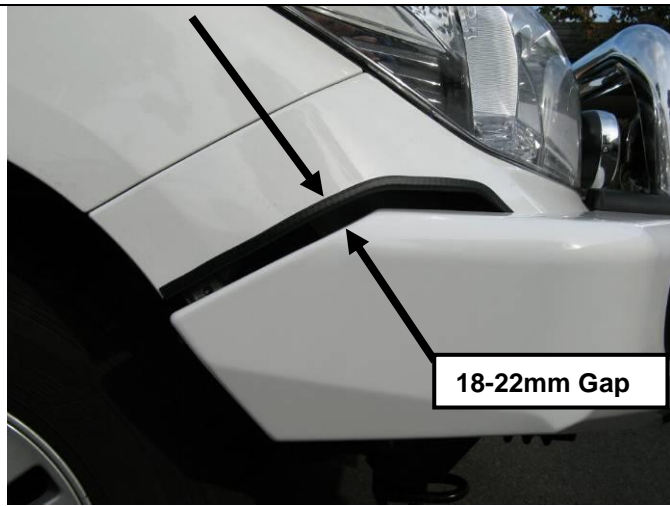

78. Adjust the bar height leaving approximately an 18-22mm gap between top of wing angled face and the pinch weld on bumper.

79. Tighten bar mount M12 bolts to 77Nm.

 M12 - 77 Nm.

80. Tighten the factory M10 flange nuts to chassis studs to **67Nm**.

 M10 (FINE) - 67 Nm.



81. Then tighten up the long M12 chassis studs, ensuring that the clevis nut is positioned correctly over the hole in the chassis.

 M12 - 77 Nm.

82. Tighten brace bolts to specified torque.

 M10 - 44 Nm.

83. Remove each tow hook bolt in turn, apply Loctite 262 © to threads and tighten to specified torque.

 M12 (FINE) - 102 Nm.

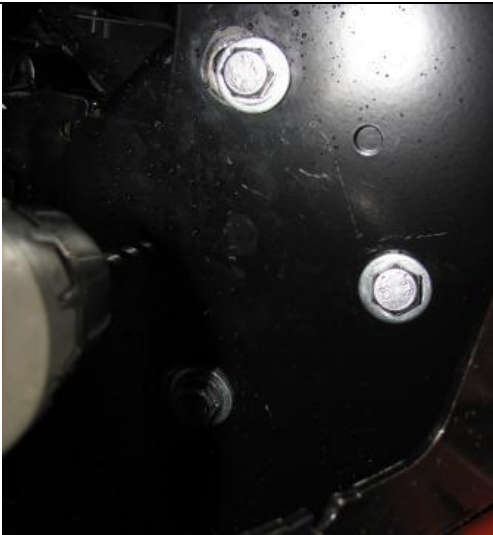

84. Using the M10 pilot holes in the bull bar uprights, drill the two pinning holes through mounting brackets on each side. Fit M10 bolt and washer sets and flange nuts and tighten to specified torque.

 M10 - 44 Nm.

HINT: Orientate drill through Foglight aperture. Right angled drill will assist.



**Warning: Drilling operations can result in flying metal debris, safety glasses should be worn.**



85. Assemble and install combination light surrounds (p/n 3163082) as per instructions no. 3789190 supplied with surround kit. Note: Optional fog lamps can be installed at this point as per fitting instruction supplied with fog lamp kit no. 3500590

86. Connect indicator looms to combination LED Indicator/Clearance light.

87. If installing fog lights Install ARB wiring loom



3500530 and switch into vehicle. Refer to instructions supplied with loom. Place switch inside cabin in a suitable position.

HINT: loosely fit top bracket to Foglight surround, then insert into Bull bar aperture. Fasten lower bracket, tighten all screws.

**CAUTION: Cable-tie all cables together and keep all cables clear of sharp edges and all moving parts.**

Check the operation of all lights wired during bar fitment



88. Fit the 4 longer leg M6 cage nuts to the lower pan of the bull bar as shown.

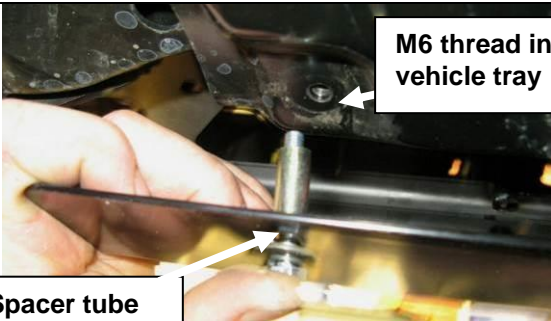
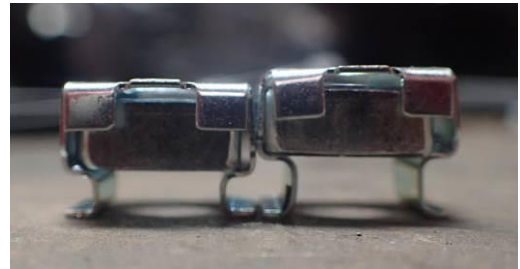

M6 thread in vehicle tray

Spacer tube

89. Fit stone tray using 4 x M6 bolts and washer sets at front under bull bar and 2 x M6 x 40 bolts, washers and 18mm long tube spacers at two locations into existing sump guard front section as shown.

 M6 - 9 Nm.

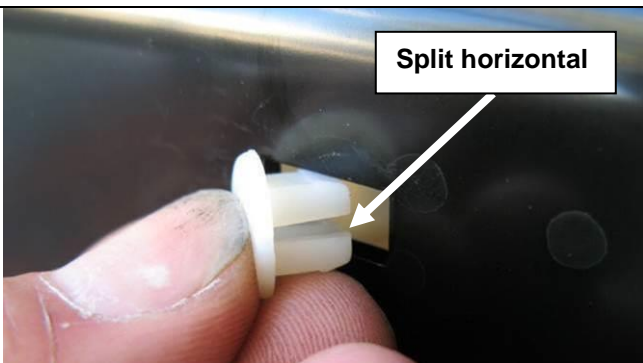

Split horizontal

90. Fit grommets to slots in number plate bracket, with split horizontal as shown

91. Fit number plate using supplied pan head screws into grommets.



92. Fit both wing panel brackets to the higher holes in the outside of the mounting brackets using M8 bolt, washer, spring washer and flange nut.

 M8 - 22 Nm.



93. Fit 5 x M6 cage nuts to each wing splash panel as shown on *inside* faces.

94. Fit panels up inside wings; secure using M6 x 20 black button head bolts and washer sets. Fix panel to side of main mount bracket using M8 bolt, washer sets and flange nut.

 M6 - 9 Nm.

 M8 - 22 Nm.



95. Trim the fender liner end flush with the splash panel face as shown. Then tuck the remaining wheel liner inside the wing panel return.

*Hint: Scribe a cutting line on the liner parallel to the splash panel.*

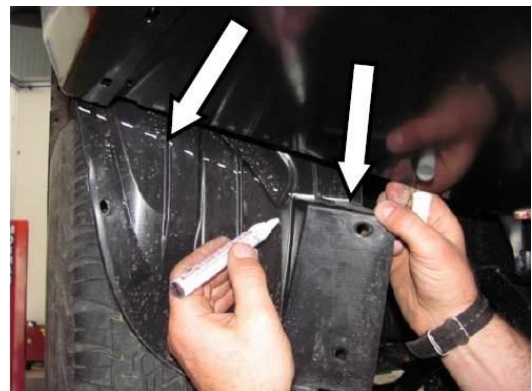

**FINAL CHECKS:**

- Check wiring connections to fitted lights.
- Check operation of all lights.
- Check operation of winch if fitted.

**IMPORTANT:** Check that all piping and wiring is clear of sharp edges and pinch points.  
Adjust any piping to clear the bull bar or mounts by a minimum of 15mm.

**FINAL PRODUCT ON VEHICLE**