



# FITTING INSTRUCTIONS

Part Number: **3750010**  
Product: **ROOF RACK MOUNTING KIT**  
Suited to **JEEP WRANGLER JL 2018 ON**  
vehicle/s:

**ALSO, NOTE THE FOLLOWING:**

- This product must be installed exactly as per these instructions using only the hardware supplied.
- In the event of damage to any component, contact your nearest authorised ARB stockist. Repairs or modifications to the impact absorption system must not be attempted.
- Do not use this product for any vehicle make or model, other than those specified by ARB.
- This product or its fixing must not be modified in any way.
- The installation of this product may require the use of specialized tools and/or techniques
- It is recommended that this product is only installed by trained personnel
- These instructions are correct as at the publication date. ARB Corporation Ltd. cannot be held responsible for the impact of any changes subsequently made by the vehicle manufacturer
- During installation, it is the duty of the installer to check correct operation/clearances of all components
- Work safely at all times
- Unless otherwise instructed, tighten fasteners to specified torque

## ARB 4x4 ACCESSORIES

Corporate Head Office

42-44 Garden St  
Kilsyth, Victoria  
AUSTRALIA 3137

Tel: +61 (3) 9761 6622  
Fax: +61 (3) 9761 6807

Australian enquiries  
North & South American enquiries  
Other international enquiries

sales@arb.com.au  
sales@arb.com.au  
exports@arb.com.au

[www.arb.com.au](http://www.arb.com.au)

# GENERAL CARE AND MAINTENANCE

## Max load SAFETY

Your ARB Roof Rack has a maximum carrying capacity of 130kg. This load should not be exceeded and all loads must be tied down securely. If you have a cage with mesh fitted, secure the load to the main framing of the cage as well as the mesh.

It is important to follow the listed usage instructions;

- a) Load should be evenly distributed and adequately secured.
- b) Any weight carried on the roof of the vehicle will adversely affect its handling, particularly in cornering or in a cross-wind; the vehicle should therefore be driven with increased discretion.
- c) Regularly check the tightness of the securing clamps and the security of the load.
- d) Attention is directed to statutory requirements regarding maximum permissible projections from vehicles.



All bolts should be checked prior to touring to ensure the rack is fastened correctly.

## FITTING REQUIREMENTS

### REQUIRED TOOLS FOR FITMENT OF PRODUCT:

Metric socket and spanner sets 8-25mm range	Ø30mm Hole Saw or Step Drill
Screwdrivers, Philips and Flat blade	Metric drill set up to 10mm
Short Body Power Drill	Marking pen
Torque Wrench (9-102Nm)	Stanley knife and scissors
Half round file	Wide masking tape
Metric hex & torx key set	Non-acetic silicone

### HAVE AVAILABLE THESE SAFETY ITEMS WHEN FITTING PRODUCT:

Protective eyewear		Hearing protection	
--------------------	---	--------------------	---

**NOTE:** 'WARNING' notes in the fitting procedure relate to OHS situations, where to avoid a potentially hazardous situation it is suggested that protective safety gear be worn or a safe work procedure be employed. If these notes and warnings are not heeded, injury may result.

### FASTENER TORQUE SETTINGS:

SIZE	Torque Nm	Torque lbft
M6	9Nm	7lbft
M8	22Nm	16lbft
M10	44Nm	32lbft
M12	77Nm	57lbft

## PARTS LISTING

APPLICATION.	PART NO.	QTY	DESCRIPTION
<b>FRONT MOUNTING</b>	3752123R	1	BRACKET FRONT RH
	3752123L	1	BRACKET FRONT LH
	4721817	6	TUBE CRUSH 12.6 x 17 x 60
	6151321	6	NUT FLANGE M10
	6151709	6	SCREW BTN HD M10
	6151381	6	BOLT M10 x 1.5 x 80
	6151359	6	NUT NYLOC M10
	4584344	18	WASHER FLAT M10
<b>REAR MOUNTING</b>	4654566R	1	WELD ASSY REAR ROOF RACK RH JL
	4654566L	1	WELD ASSY REAR ROOF RACK LH JL
	3752122R	1	BRKT MNT REAR RH ROOF RACK JL
	3752122L	1	BRKT MNT REAR LH ROOF RACK JL
	6582434	2	CLAMP FRAME 35
	6151173	8	NUT FLANGE M6
	6151443	8	SCREW BTN HD M6
	6151709	4	SCREW BTN HD M10
	6151359	4	NUT NYLOC M10
	6151342	2	SCREW 12G 20LG SL
	4584344	8	WASHER FLAT M10
<b>ROOF RAILS</b>	3752124R	1	BRKT RAIL RH ROOF RACK JL
	3752124L	1	BRKT RAIL LH ROOF RACK JL
	6151184	12	SCREW M8 x 1.25 x 30 SS
	4581081	12	WASHER FLAT M8
	3193522	6	BOLT PLATE ASSY
	3193757	6	PLATE SUPPORT RACK
<b>MISCELLANEOUS</b>	5848487	10	PACKER RUBBER GASKET

## HOLE DRILLING



1. Open the rear doors and locate the 2 holes shown within the roll bar of the vehicle above the rear seats.



2. Locate the front hole shown within the roll bar of the vehicle approximately located above front seat head rest.
3. With the help of another person, detach hard top roof from vehicle and set aside along with fasteners.
4. Carefully drop and position 6x crush tubes through the top opening at hole locations specified on both sides in steps 1 & 2.

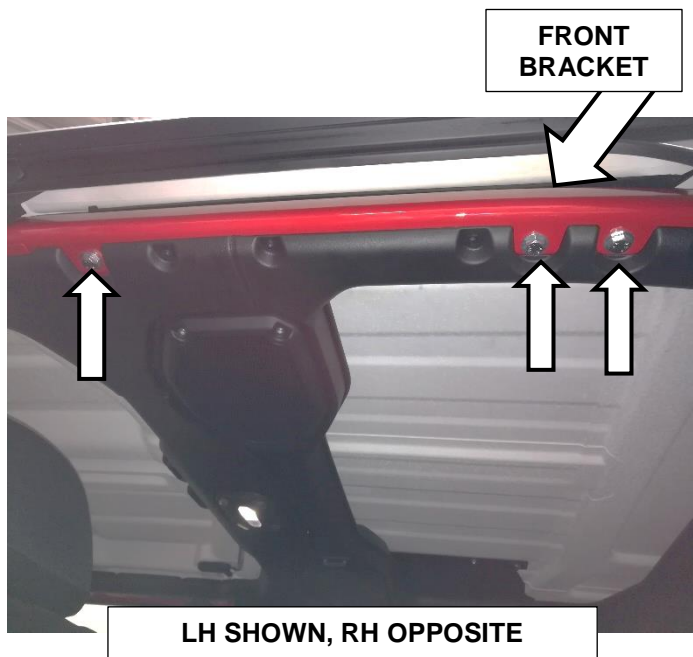

5. With the help of another person, re-position hard top roof to vehicle however do not fully attach as it will be removed again shortly.
6. Fasten front bracket above roll bar as shown using 6x M10x1.5x80mm, 6x M10 flat washers & 6x M10 flange nuts.

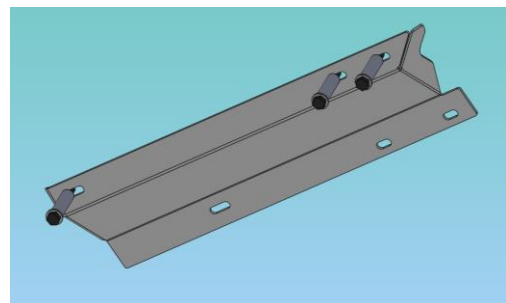

 M10 - 44Nm (32lbft)

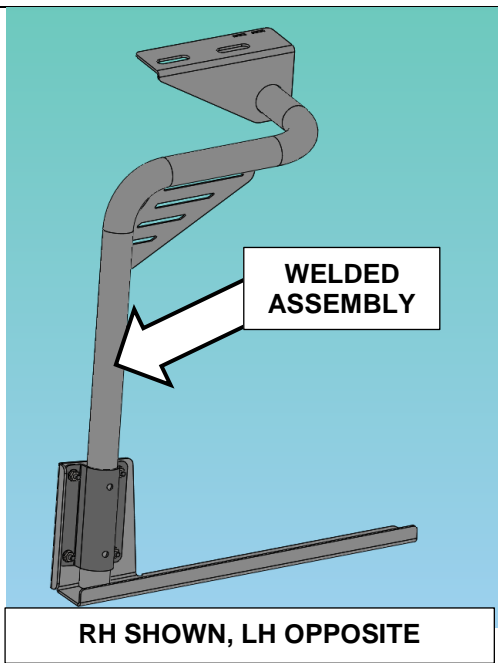

- Loosely assemble rear mount bracket and welded tube assembly using clamp and M8 hardware supplied in kit.

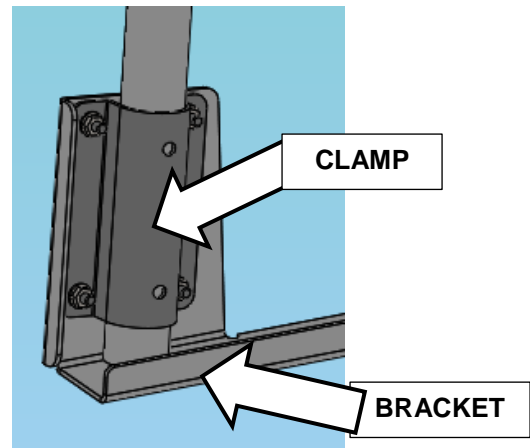

- Loosely fasten assembly at rear of vehicle as shown using existing hardware removed in step 3.

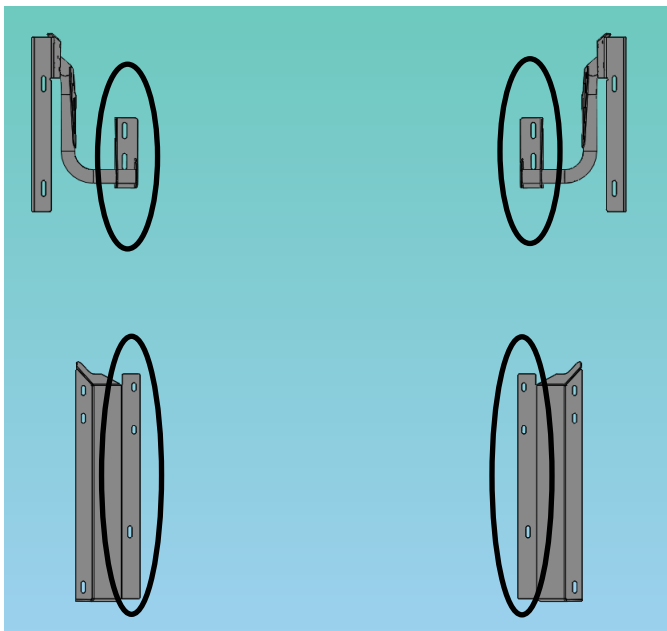

- Looking upwards, mark 10 centre hole positions onto inside of roof using slots in mount brackets as guides for both front and rear mounts.

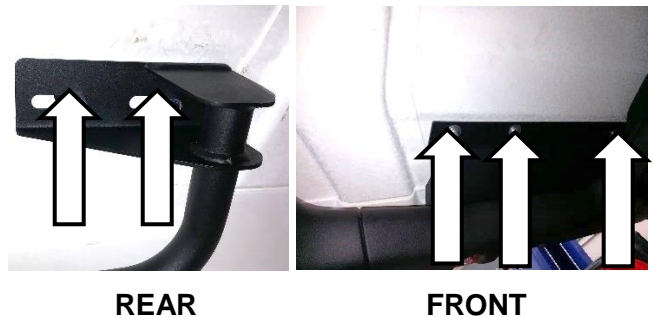

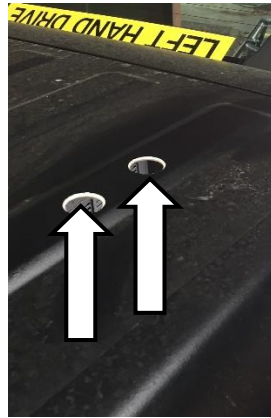

LH SHOWN, RH OPPOSITE

10. Remove roof from vehicle once again and carefully drill 10x 11mm holes at positions marked in previous step using an 11mm drill bit and file away any burrs.

**Note:** You will have to temporarily remove rear mount brackets also.

11. Reposition roof as per manufacturers recommendations, re-fit rear mount brackets and assembly.

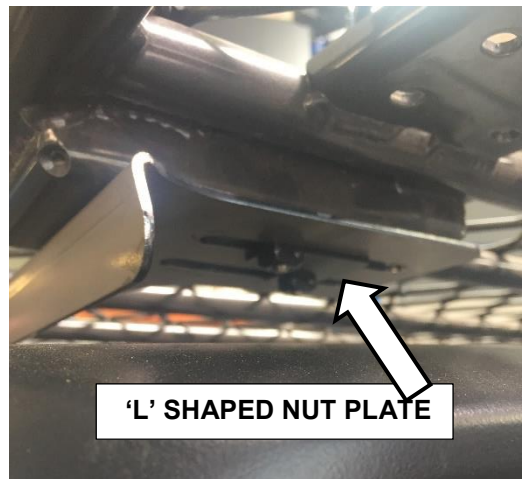
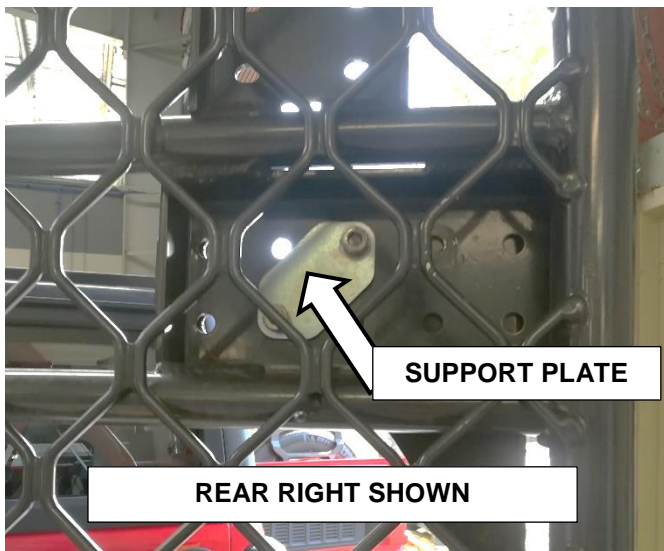

12. Loosely fasten rack to rails using 12x M8 SS Cap Screws, 12x Flat Washers, 6x nut plates & 6x rack support plates.

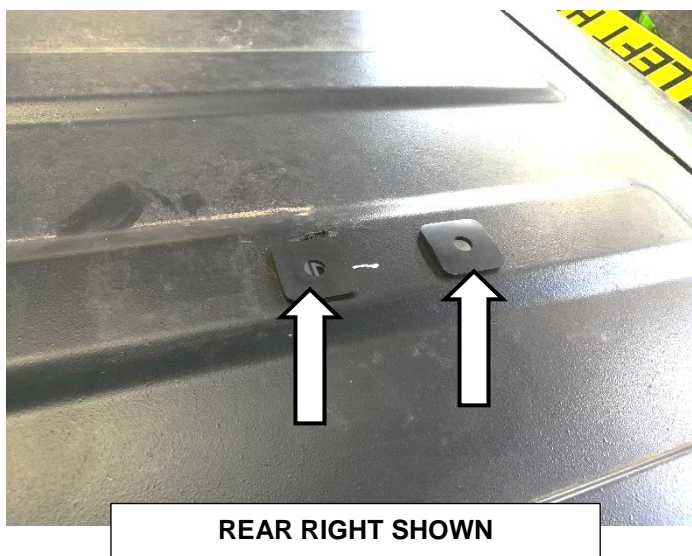

13. Position 10x rubber gaskets directly on top of holes drilled in roof and position both rails directly on top of gaskets aligning with slots in rails.

14. Apply a bead of non-acetic silicone to both sides of gasket around bolt hole.

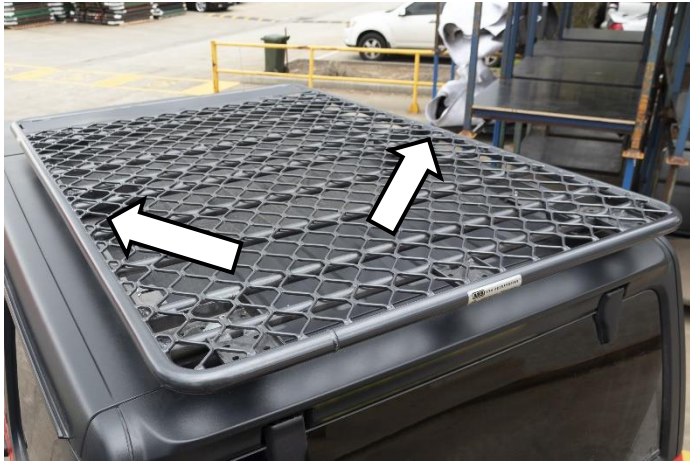

15. Loosely fasten rails (with rack attached) to front and rear brackets using 10x M10 Button Head bolts, 20x M10 flat washers & 10 x M10 Nyloc nuts.

**Note:** Button head bolts located at centre of rack will need to be fed upwards (head inside the cabin).



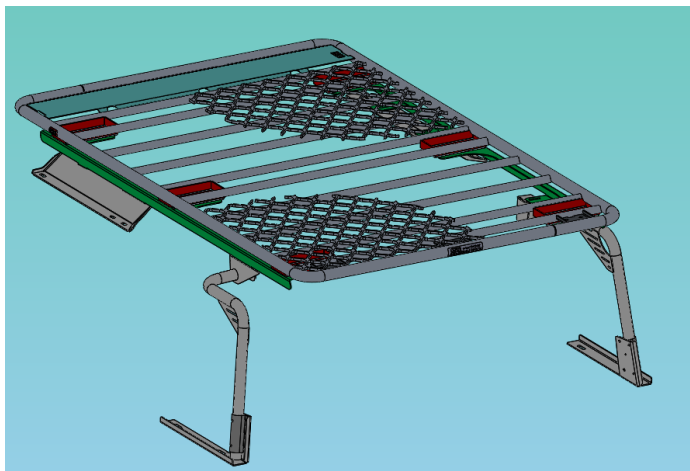

16. With all the bolts in place, align the roof rack centrally on the vehicle *and tighten the bolts to specified torque.*

**HINT:** When removing your roof rack, due to the cap screws having a Loctite coating on the threads, don't fully remove the first screw before undoing the second one to prevent the nut plate from rotating.



17. Tighten all fasteners beginning with bracket - vehicle and then proceeding to rails – rack.

 M8 - 22Nm (16lbft)

 M10 - 44Nm (32lbft)



18. Drill a 4mm hole into rear mounting tube as shown using 4mm drill bit and repeat on opposite side.
19. Screw 2x 12G self-tapping screws into positions drilled.



**FITTED PRODUCT**  
**LOAD TO NOT EXCEED 130kg**  
**RE-TORQUE FASTENERS AFTER 1000kms**

