



FITTING INSTRUCTIONS

Part Number: **3515090**
Product **Front Camera Relocation kit TOYOTA LC200**
Description:
Suited to **TOYOTA LANDCRUISER SAHARA 200 SERIES 2015 ON.**
vehicle/s: **COMPATIBLE WITH 3415220, 3215210 & 3915210**

WARNING

NOTE THE FOLLOWING:

- ◆ This product must be installed exactly as per these instructions using only the hardware supplied.
- ◆ In the event of damage to any bull bar component, contact your nearest authorised ARB stockist. Repairs or modifications to the impact absorption system must not be attempted.
- ◆ Do not use this product for any vehicle make or model, other than those specified by ARB.
- ◆ This product or its fixing must not be modified in any way.
- ◆ The installation of this product may require the use of specialized tools and/or techniques
- ◆ It is recommended that this product is only installed by trained personnel
- ◆ These instructions are correct as at the publication date. ARB Corporation Ltd. cannot be held responsible for the impact of any changes subsequently made by the vehicle manufacturer
- ◆ During installation, it is the duty of the installer to check correct operation/clearances of all components
- ◆ Work safely at all times
- ◆ Unless otherwise instructed, tighten fasteners to specified torque

ARB 4x4 ACCESSORIES

Corporate Head Office

42-44 Garden St
Kilsyth, Victoria
AUSTRALIA 3137

Tel: +61 (3) 9761 6622
Fax: +61 (3) 9761 6807

Australian enquiries
North & South American enquiries
Other international enquiries

sales@arb.com.au
sales@arb.com.au
exports@arb.com.au

www.arb.com.au

GENERAL CARE AND MAINTENANCE

- As part of any Pre Trip Preparation, or on an annual basis, it is recommended that a thorough visual inspection of the bull bar and camera is carried out, making sure that all bolts and other components are torqued to the correct specification. Also check that all wiring sheaths, connectors, lens and fittings are free of damage. Replace any components as necessary. This service can be performed by your local authorized ARB Stockist.

ATTENTION:



ARB Corporation cannot be held responsible for any change in the performance and any subsequent consequences relating to the relocation of the front grille mounted camera for the Toyota Land Cruiser 200 series.

FITTING REQUIREMENTS

REQUIRED TOOLS FOR FITMENT OF PRODUCT:

| | |
|--------------------------------------|---|
| Screwdrivers, Philips and Flat blade | Metric socket and spanner sets 8-25mm range |
| Long nose pliers | Side Cutters |
| Fine Point Sewing Needle/Pin | Torque Wrench (9Nm) |
| Electrical Tape | |

HAVE AVAILABLE THESE SAFETY ITEMS WHEN FITTING PRODUCT:

| | | | |
|--------------------|---|--------------------|---|
| Protective eyewear |  | Hearing protection |  |
|--------------------|---|--------------------|---|

NOTE: 'WARNING' notes in the fitting procedure relate to OHS situations, where to avoid a potentially hazardous situation it is suggested that protective safety gear be worn or a safe work procedure be employed. If these notes and warnings are not heeded, injury may result.

FASTENER TORQUE SETTINGS:

| SIZE | Torque Nm | Torque lbft |
|------|-----------|-------------|
| M5 | 5Nm | 4lbft |
| M6 | 9Nm | 7lbft |
| M8 | 22Nm | 16lbft |
| M10 | 44Nm | 32lbft |
| M12 | 77Nm | 57lbft |

PARTS LISTING

| APPLICATION. | PART NO. | QTY | DESCRIPTION |
|-------------------------|----------|-----|---------------------------------|
| Camera To Mount Bracket | 4654217 | 1 | Brkt LC200 Camera Nut Assy |
| | 4654223 | 1 | Brkt LC200 Cam Winch Nut Assy |
| Camera To Bull Bar | 6821325 | 1 | Wiring Camera Loom Extension |
| | 6151213 | 2 | Bolt M6 x 1.0 x 20 Gd8.8 BZ |
| | 4584295 | 2 | Washer Flat M6x12x1.3 BLK ZN |
| | 4581287 | 2 | Washer Spring M6x2.5x1.6 BLK ZN |
| | 180302 | 4 | Cable Ties |

FITTING PROCEDURE



1. Remove plastic engine bay cover above grill area and set aside. Press down on centre of plastic plugs with small screwdriver or similar to release.

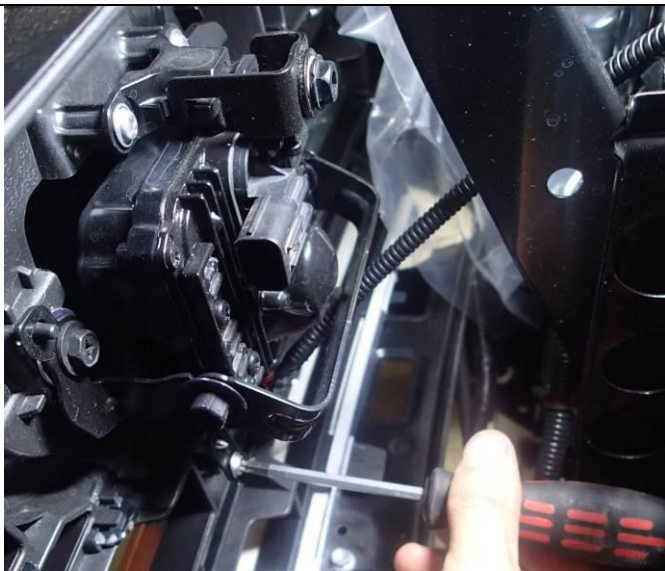

2. Unplug camera then unscrew both phillips head screws and remove from vehicle.

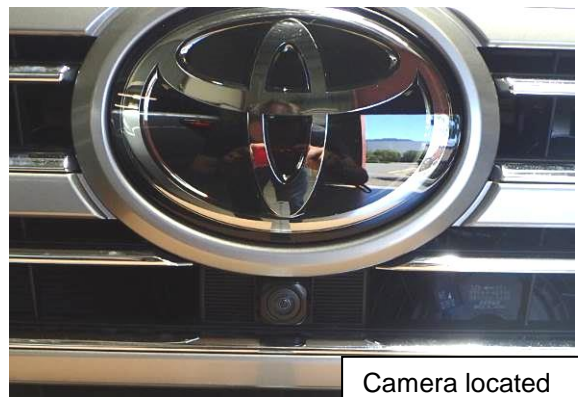

Camera located underneath Toyota badge

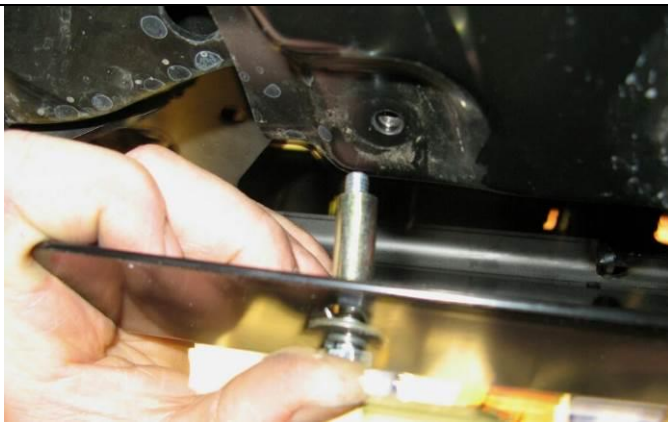

3. If centre stone shield is fitted remove by unbolting M6 hardware.

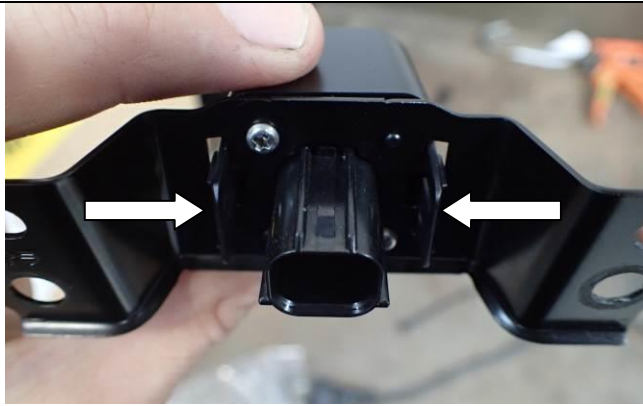

4. Separate OEM steel bracket from back of camera by removing two Philips head screws and depressing shroud clips.

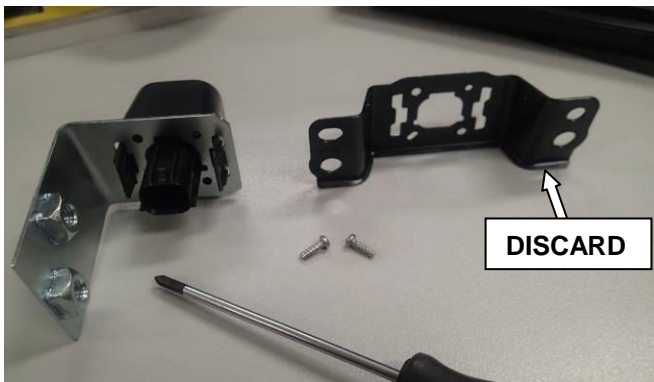

IF BULLBAR IS WINCH COMPATIBLE CONTINUE TO STEP 5. IF BULL BAR IS NOT WINCH COMPATIBLE SKIP TO STEP 8.

5. For winch compatible bull bars, reinstall the camera and plastic shroud into the bracket shown adjacent (4654223) and fasten with original phillips head screws.

Discard both OEM and ARB non-winch bracket.

HINT: Make sure clips on plastic shroud are splayed in order to lock shroud in place.

6. SINGLE DOOR GRILLE:

Neatly remove the horizontal section of the grille (circled and highlighted below) in the 5th column from the centre of the grille. This can be done with the grille fixed into the bull bar with side cutters or similar.

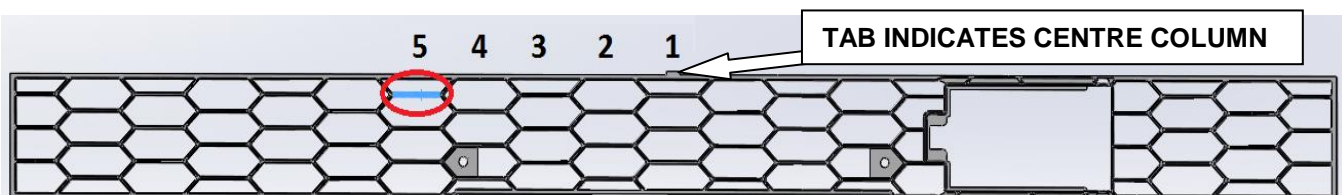

DOUBLE DOOR GRILLE:

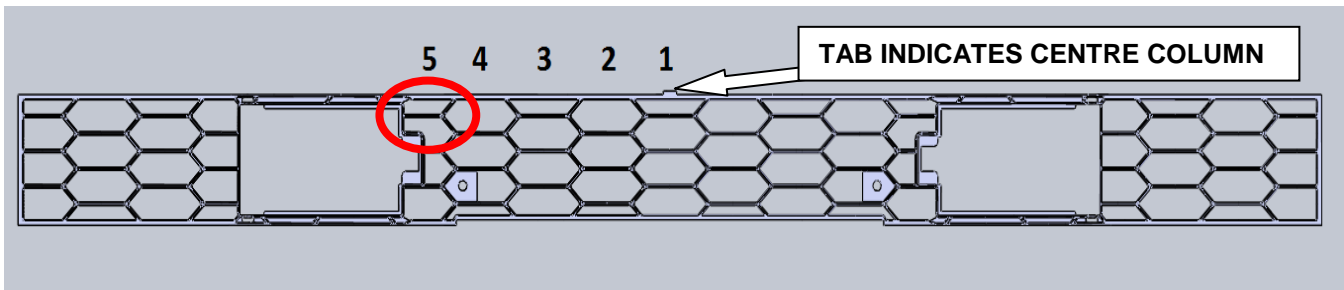

Using an oscillating multitool, neatly remove the section of the grille (circled above and detailed below) in the 5th column from the centre of the grille.

BEFORE:

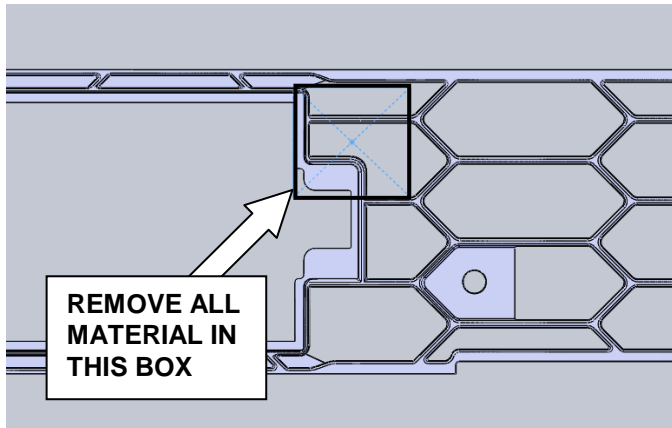

AFTER:

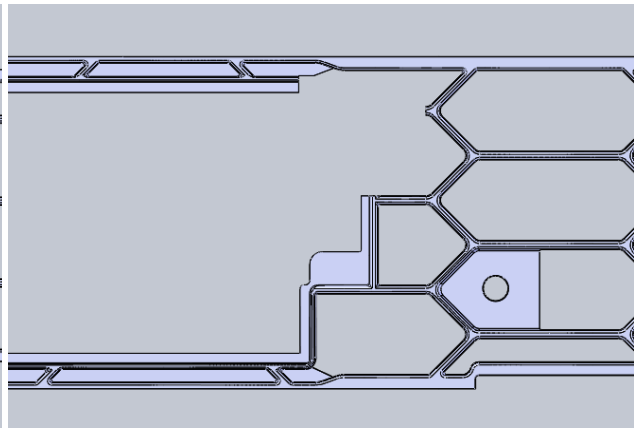

7. Attach camera and bracket assembly to driver's side of winch cradle with M6 hardware as shown.



 M6 - 9Nm

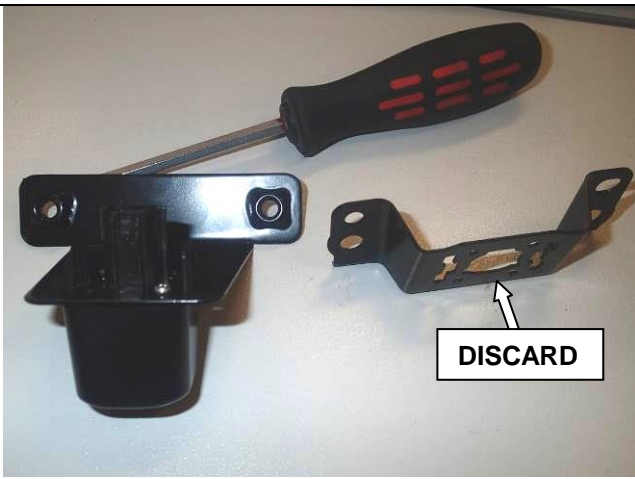

IF BULLBAR IS WINCH COMPATIBLE SKIP TO STEP 11.

8. For bull bars which are not winch compatible, reinstall the camera and plastic shroud into the bracket shown adjacent (4654217) and fasten with original phillips head screws.

Discard both OEM and ARB winch bracket.

HINT: Make sure clips on plastic shroud are splayed in order to lock shroud in place.

9. Neatly remove the horizontal section of the grille (circled and highlighted below) in the central column of the grille. This can be done with the grille fixed into the bull bar with side cutters or similar.

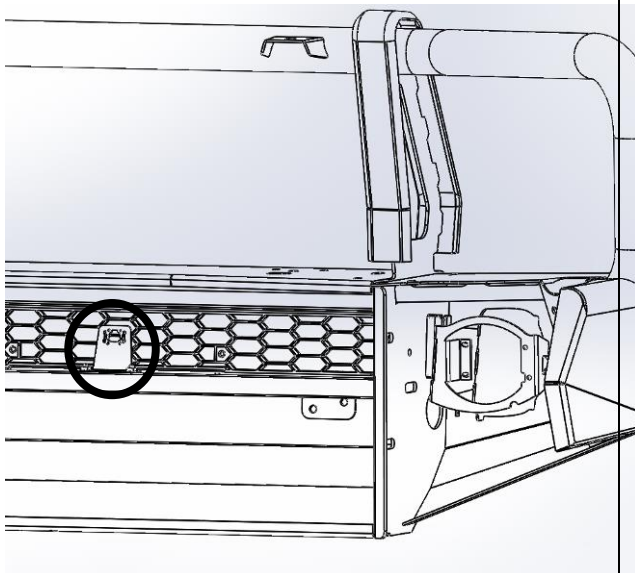
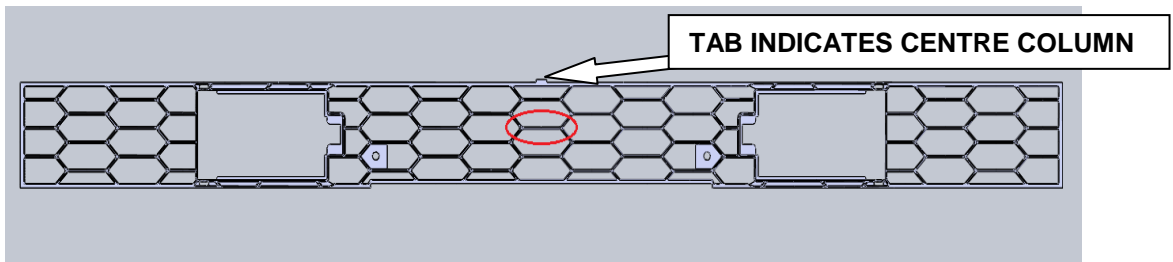

10. Attach camera and bracket assembly to centre of the lower pan with M6 hardware as shown.

Note: Be sure to check that the bracket is mounted horizontal and not on an angle as this will show on the viewing screen.



 M6 - 9Nm

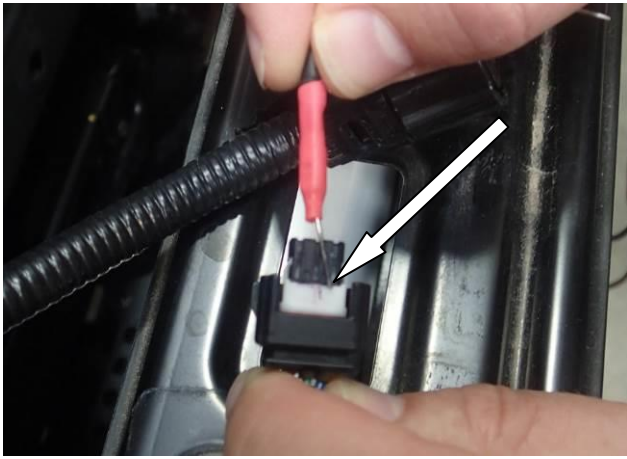

11. Loom Rehouse Instructions

Using a small flat blade jewellery screwdriver pry up the white secondary lock on the underside of the camera connector plug. The white lock should only move a few millimetres in order to free the terminals.



12. Using a sharp point, push down front of terminal while gently pulling wire out from the back of the plug.

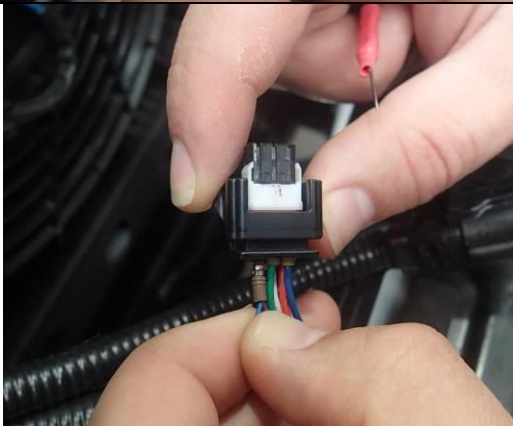

13. Once wire is free, gently extract it from the plug completely.

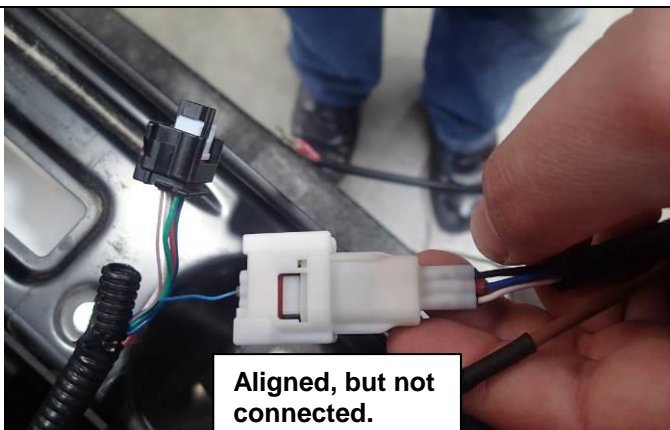

14. As each terminal is removed from the camera plug, rehouse it into the new female plug supplied with loom. (SEE STEP 15)

Hint: Align, but do not connect extension loom to help match the colours for rehousing the terminals.

(numbers on the back of the connectors also correspond)

When rehousing crimped terminals into the new female plug, make sure that the

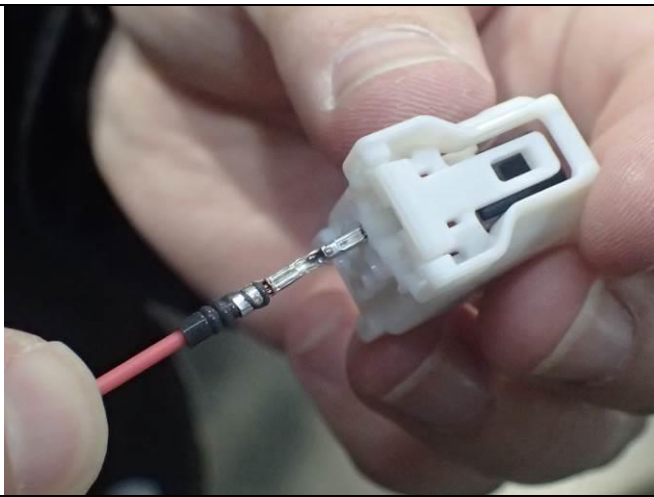

orientation of the terminal is such that the crimp bucket is facing up towards the clip as shown.

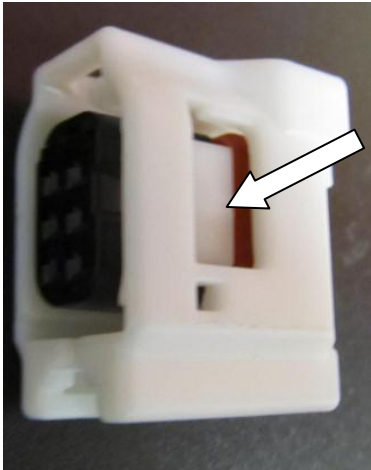

15. Check the wires are inserted into the correctly numbered holes (numbered 1-6 next to the hole)

| HOLE # | WIRE COLOUR |
|--------|--------------|
| Hole 1 | PINK |
| Hole 2 | WHITE |
| Hole 3 | RED |
| Hole 4 | BLUE (FINE) |
| Hole 5 | GREEN |
| Hole 6 | BLUE (THICK) |

When all 6 wires are rehoused, depress secondary lock inwards as shown.



16. Apply electrical tape to insulate exposed areas of loom and hold convoluted tube as shown.



17. Plug the supplied camera loom into the connector (now part of vehicle loom) and route down under the grill so it can be plugged into the camera.



18. Plug the open end of the supplied loom into the back of the camera and check for operation, zip tie loom to ensure movement is limited and it is well clear of any moving parts. Check there is no exposed wires at the camera end and they are protected by the conduit, use electrical tape to fix the conduit in position.

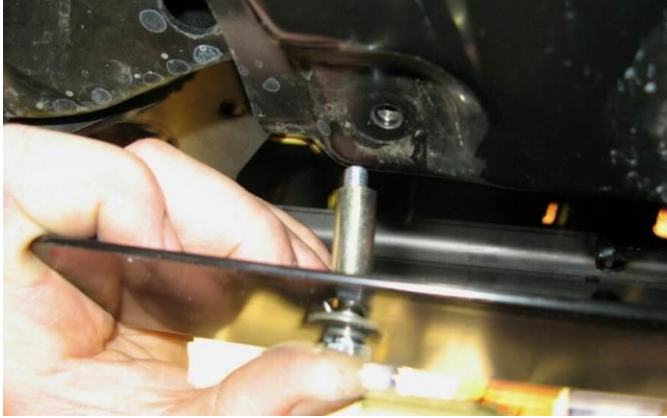

19. Replace stone shield using existing M6 hardware and tighten to specified torque.
20. Refit plastic engine bay cover by re-clipping.

 M6 - 9Nm

- ◆ **Check operation of front vehicle camera.**
- ◆ **IMPORTANT: Check that all piping and wiring is clear of sharp edges and pinch points. Adjust any piping to clear the bull bar or mounts by a minimum of 15mm.**

FITTED PRODUCT

****NOTE IMAGE SHOWN IS FOR WINCH COMPATIBLE BAR WITH DOUBLE DOOR GRILLE****

