



FITTING INSTRUCTIONS

Part Number: **3500930**

Product **SUMMIT BAR WINCH INSTALL KIT INTEGRIT**

Description:

Refer to Bull Bar fitting instructions for winch compatibility.

Winches may require additional fitting kits. Refer to table below for details.

WINCH MODEL	ADDITIONAL KITS
Zeon 8:	W89965 WARN ZEON EXTENDED CABLE KIT
Zeon 8s:	W89965 WARN ZEON EXTENDED CABLE KIT & 3500600 HAWSE FAIRLEAD ADAPTER KIT
Zeon 10:	W89965 WARN ZEON EXTENDED CABLE KIT
Zeon 10s:	W89965 WARN ZEON EXTENDED CABLE KIT & 3500600 HAWSE FAIRLEAD ADAPTER KIT
Zeon 12:	W89965 WARN ZEON EXTENDED CABLE KIT
Zeon 10 Platinum:	W89965 WARN ZEON EXTENDED CABLE KIT
Zeon 10-s Platinum:	W89965 WARN ZEON EXTENDED CABLE KIT & 3500600 HAWSE FAIRLEAD ADAPTER KIT
Zeon 12 Platinum:	W89965 WARN ZEON EXTENDED CABLE KIT
XP:	-
XP:	3500600 HAWSE FAIRLEAD ADAPTER KIT
M8000:	-
M8000s:	3500600 HAWSE FAIRLEAD ADAPTER KIT
XD9:	-
XD9s:	3500600 HAWSE FAIRLEAD ADAPTER KIT
9.5XDC:	3500410 WARN XDC ADAPTER KIT
9.5XDC-s:	3500600 HAWSE FAIRLEAD ADAPTER KIT & 3500410 WARN XDC ADAPTER KIT
Magnum 8:	-
Magnum 8s:	3500600 HAWSE FAIRLEAD ADAPTER KIT
Magnum 10:	-
Magnum 10s:	3500600 HAWSE FAIRLEAD ADAPTER KIT
Magnum 12:	-
Bushranger DV9TH:	3500780 BUSHRANGER CABLE COVER KIT (OPTIONAL)
Bushranger Seal 9.5TH:	3500600 HAWSE FAIRLEAD ADAPTER KIT & 3500780 BUSHRANGER CABLE COVER KIT (OPTIONAL)
Bushranger DV12TH:	3500780 BUSHRANGER CABLE COVER KIT (OPTIONAL)
Smittybilt X20 10lbs cable:	3500770 SMITTYBILT ADAPTER KIT
Smittybilt X20 10lbs rope :	3500600 HAWSE FAIRLEAD ADAPTER KIT and 3500770 SMITTYBILT ADAPTER KIT

ARB 4x4 ACCESSORIES

Corporate Head Office

42-44 Garden St
Kilsyth, Victoria
AUSTRALIA 3137

Tel: +61 (3) 9761 6622
Fax: +61 (3) 9761 6807

Australian enquiries
North & South American enquiries
Other international enquiries

sales@arb.com.au
sales@arbusa.com
exports@arb.com.au

www.arb.com.au

FITTING REQUIREMENTS

HAVE AVAILABLE THESE SAFETY ITEMS WHEN FITTING PRODUCT:

Protective eyewear



Hearing protection



NOTE: 'WARNING' notes in the fitting procedure relate to OHS situations, where to avoid a potentially hazardous situation it is suggested that protective safety gear be worn or a safe work procedure be employed. If these notes and warnings are not heeded, injury may result.

FASTENER TORQUE SETTINGS:

SIZE	Torque Nm	Torque lbft
M6	9Nm	7lbft
M8	22Nm	16lbft
M10	44Nm	32lbft
M12	77Nm	57lbft

PARTS LISTING

ITEM NO.	PART NUMBER	DESCRIPTION	QTY.
1	3194775	PLATE CABLE GUARD SUMMIT BARS	1
2	3750122	NUMBER PLATE BRACKET LIFT UP	1
3	3750123	NUMBER PLATE BRACKET MOUNT	1
4	3759658	WARN CONTROL BOX BRACKET SUMMIT BARS	1
5	4581287	WASHER SPRING M6 x 2.5 x 1.6 BLACK ZINC	4
6	4584295	WASHER FLAT M6 X 12 X 1.3 BLACK ZINC	8
7	5848302	PACKER NYLON	2
8	6151074	BOLT UNC 3/8 X 1 3/4	2
9	6151213	BOLT M6 x 1.0 x 20 8.8 BLACK ZINC	2
10	6151223	NUT NYLOC M6 x 1.0 BLACK ZINC	2
11	6151384	SCREW 5.2 X 16 BLACK ZINC	4
12	6151456	BOLT M10 x 1.5 x 45 ZINC	2
13	6151550	BOLT M6 x 1.0 x 25 PC8.8 BLACK ZINC	4
14	6151561	NUT FLANGE M6 x 1.0 BLACK ZINC	4
15	6250010	SPACER 17 X 12.6 X 10	4
16	6821189	NUMBER PLATE GROMMET	4

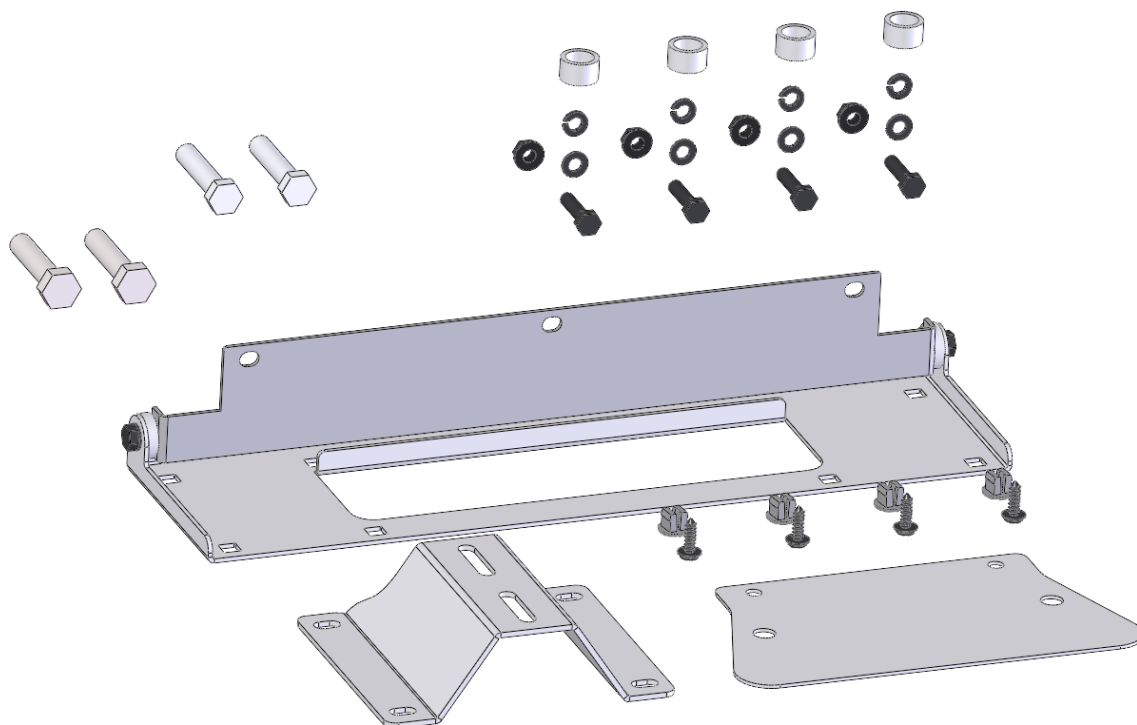

WINCH PREPERATION

This ARB bar has been designed to carry a variety of Warn, Magnum, Smittybilt and Bushranger winches. Before the winch is fitted into the bar it will need to be configured for proper fit and operation.

Note: Before fitting the winch to the bar, ensure that you have read and understand the fitting instructions supplied with the winch. These instructions only cover the fitment of the winch and control box to the bar. They do not cover the wiring procedure. For this refer to the winch manufacturer's instructions.

You will need to modify your winch to allow fitment into the bar. See below for each of the winch brands:

Note: The pictures below show the winches following modification.

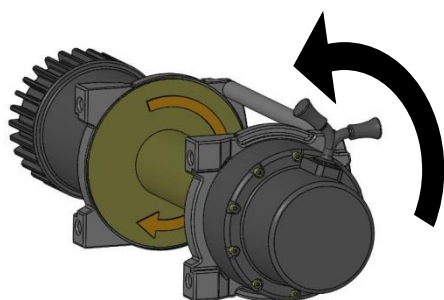

Warn / Magnum / Smittybilt winches: Undo the screws in the gearbox end of the winch. Carefully slide the gearbox away from the winch only until it is able to rotate. Rotate the gear box anti-clockwise 72° and replace screws.

Smittybilt winches only. Motor will need to be rotated for adequate cable length. Remove 4 motor retaining bolts and cover. Remove 2 additional motor cap bolts. Rotate the motor until electrical connections are facing upwards. Reinstall retaining bolts and motor cover.

Ensure drain holes are correctly orientated. Refer to winch instructions for more details.

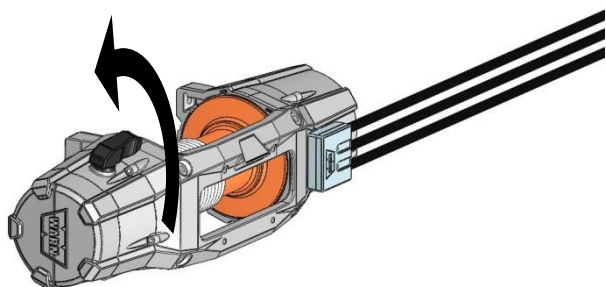

Warn Zeon winches*: Undo the screws in the gearbox end of the winch. Carefully slide the gearbox away from the winch only until it is able to rotate. Rotate the gear box anti-clockwise 72° and replace screws.

Remove the control box as per the Zeon control pack relocation kit installation guide.

Install the Warn Zeon relocation kit to the winch and control box.

***Not required for Zeon Platinum models.**

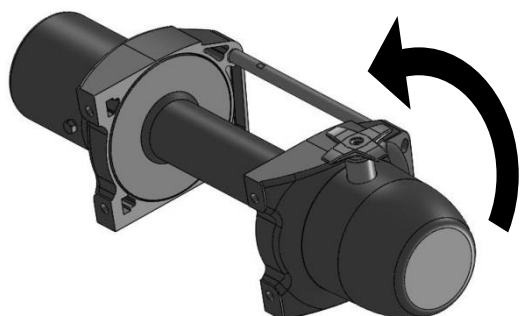

Bushranger winches: Undo the screws in the gearbox end of the winch to remove the brake cover. Remove the bolts retaining the gearbox housing.

Rotate the gearbox anti-clockwise until the clutch is as close as possible to directly upwards. Gearbox rotation increments may be 36°, 40° or 90° depending on model.

Ensure fine seals are seated correctly then replate and tighten all fasteners.

Ensure drain holes are correctly orientated. Refer to winch instructions for more details.

FITTING PROCEDURE

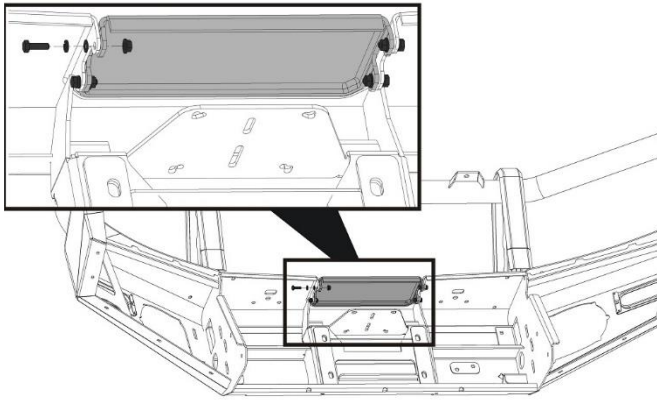

1. Lay the bar face down on a soft surface so as not to damage the paint / powder coat.
2. If fitted, carefully remove the winch cover plate and discard.

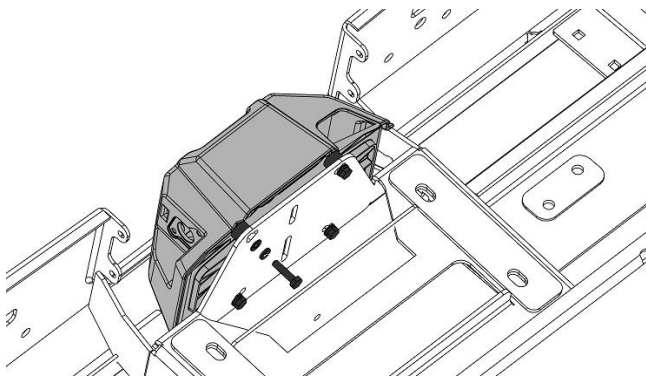

3. Attach the winch control box to the flat surface inside the bar as shown.

Warn Zeon winches: Use the spacers, M6 x 25 hex bolts, spring washers and flat washers supplied in this install kit.

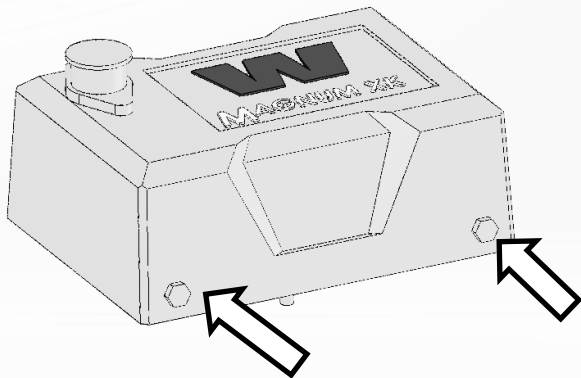
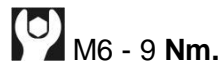

Warn Magnum winches:

1. Remove top cover from winch by removing 3X M4 bolts from side of plastic cover.



1. Undo 2 X supplied M6 nuts from underside of control box. To do so, top of M6 bolts located on the inner side of the box will need to be held in place.



1. Attach control box to control box bracket using fasteners removed from control box in earlier step, so that the top face of the bracket is flush with the bottom surface of the control box.

Do not fully tighten.

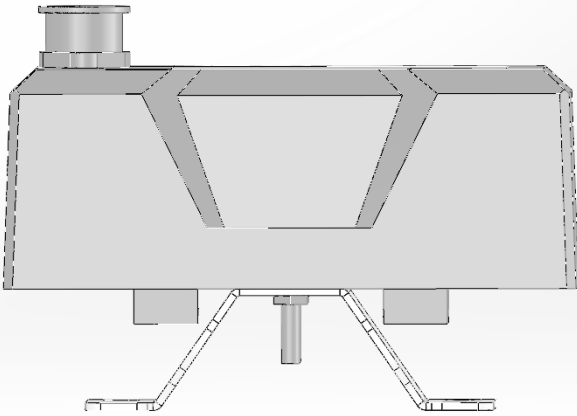

2. Secure plastic back onto control box, taking care to leave the two supplied bolts in position.

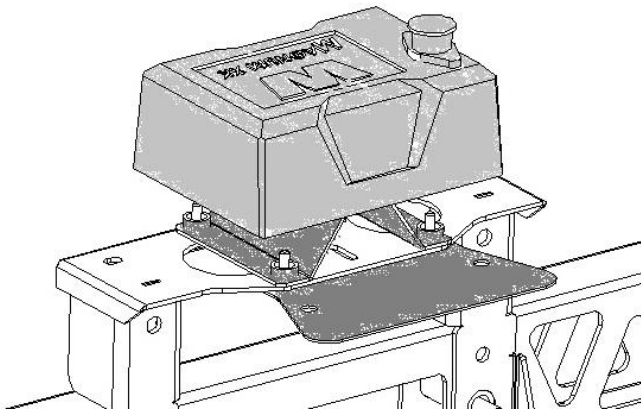

3. Attach bracket and cable protector as shown using and M6x25 hex bolts, spring washers, flat washers and flange nuts provided. **Ensure the cut-out edge of bracket faces the front of the bar..**

 M6 - 9 Nm.

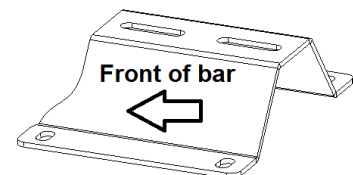

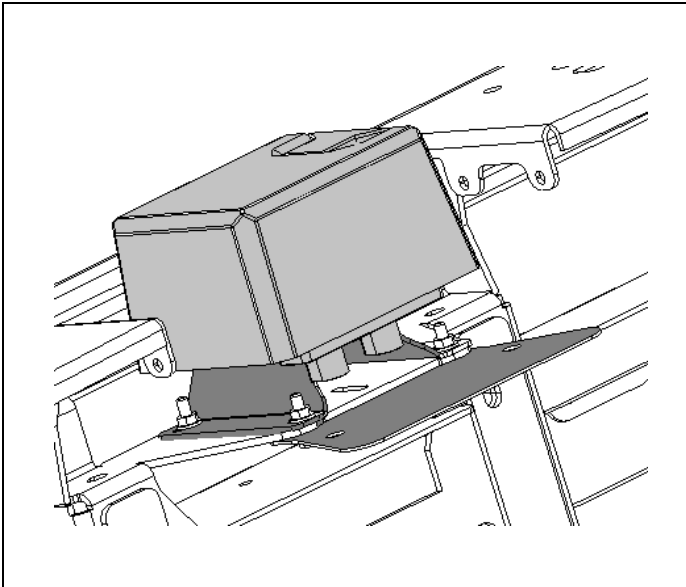

Warn "Contactor" control box winches.

Attach control box to control box bracket using fasteners from Warn kit. Do not fully tighten.

Attach bracket and cable protector as shown using M6x25 hex bolts, spring washers, flat washers and flange nuts provided. **Ensure cut-out edge of bracket faces rear of bar.**

Adjust control box until it is approximately 5mm off front of control box recess and tighten all fasteners.

 M6 – 9 Nm

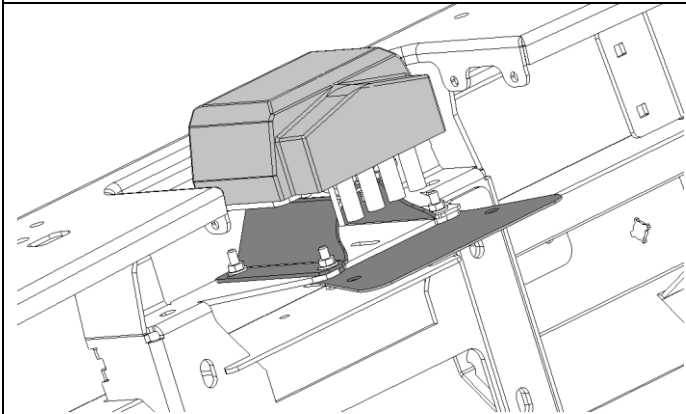
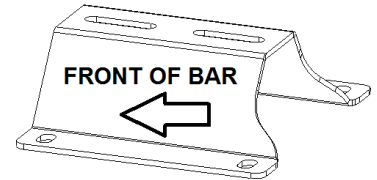

Smittybilt Gen 2 winches. Require Smittybilt adapter kit 3500770

Using adapter bracket, attach Smittybilt control box to the Summit bar control box bracket.

Use 4x screws from Smittybilt kit.

2x M6 Bolt nut and washer sets from adapter bracket kit.

Attach assembly and cable protector to Bull Bar as shown using 4x M6x25 bolt, washer and nut sets as shown

Ensure cut-out edge of bracket faces rear of bar.

Adjust control box until it is approximately 5mm off front of control box recess and tighten all fasteners.

 M6 - 9 Nm.

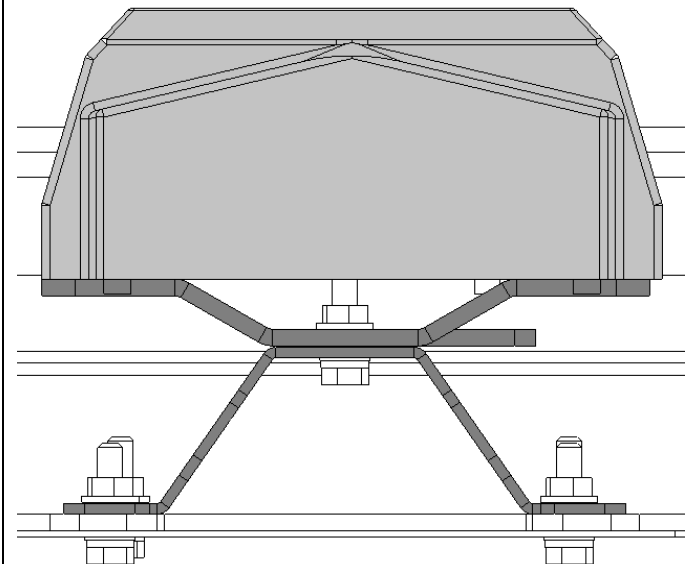
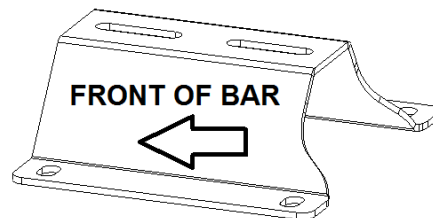

Brackets set up shown from rear of bar. Control box cables not shown for clarity.

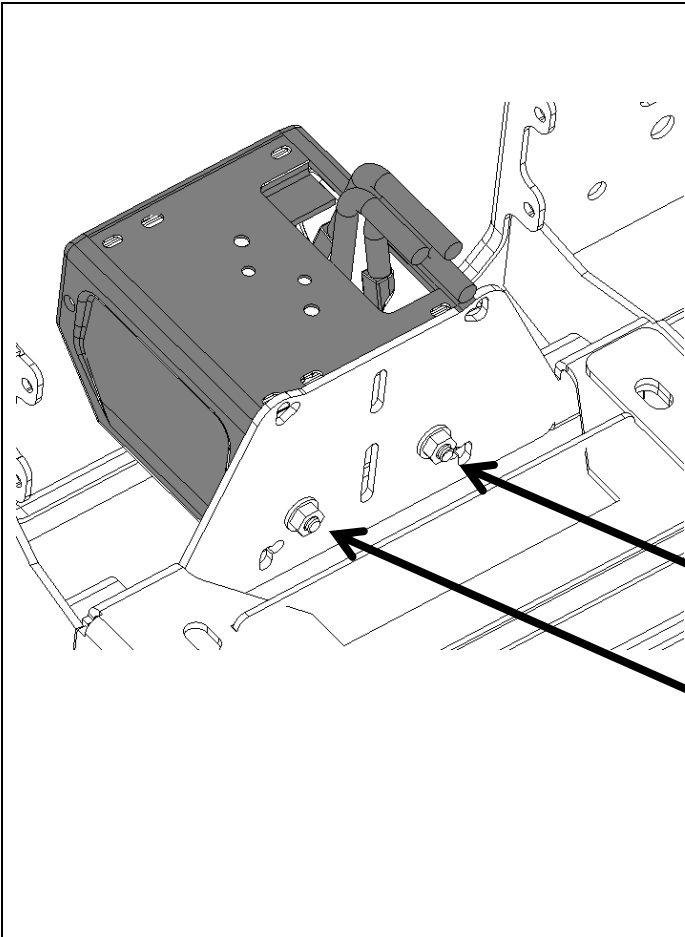

Bushranger winches. First remove one plastic end from the control box. Slide in two Hex head M8x20 bolts. (not provided).

Replace plastic end of the control box and fasten to bullbar using M8 nut and washer set (not provided)

If desired optional cover kit 3500780 can be fitted to back of bushranger control box.

 M8 - 22 Nm.

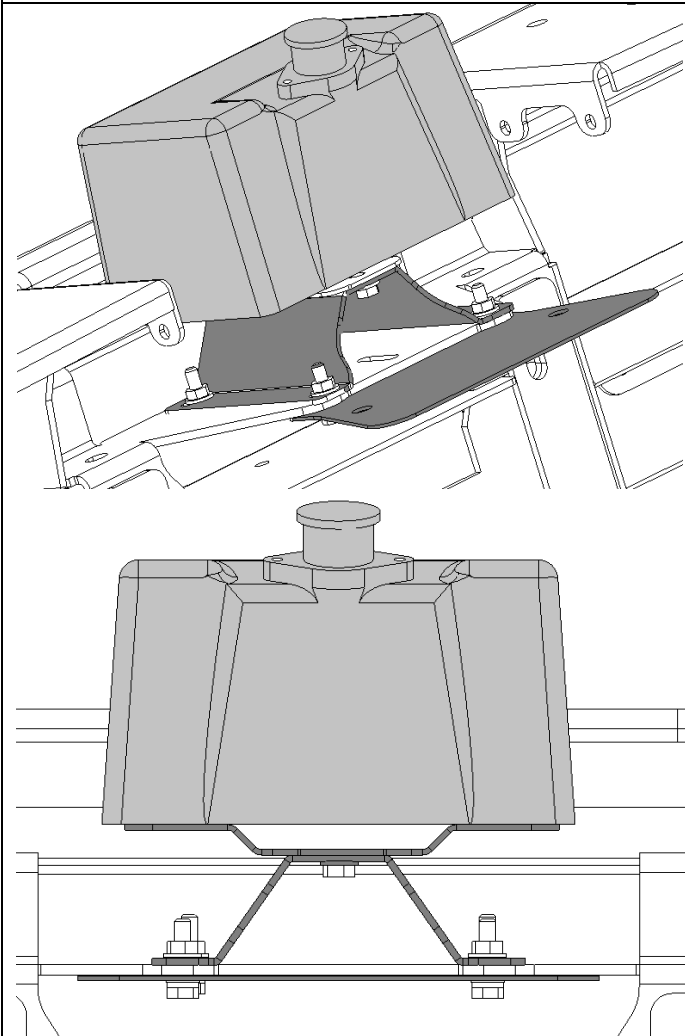
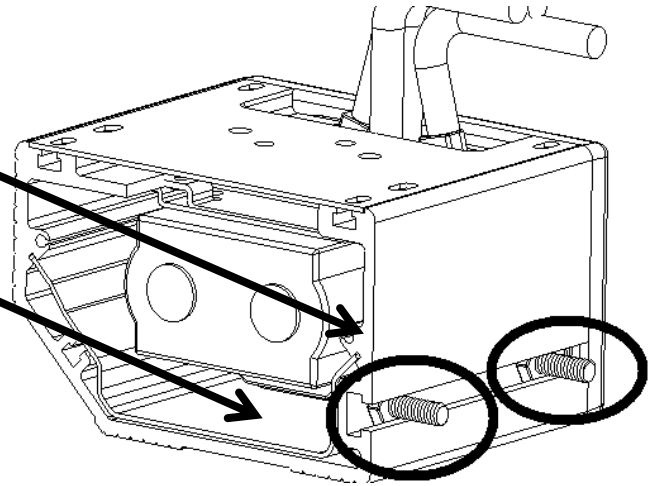

Warn XDC winches require adapter kit 3500410

Using adapter bracket, attach control box to the Summit bar control box bracket.

Use 4x M6 Bolt nut and washer sets from adapter bracket kit.

Attach assembly and cable protector to Bull Bar as shown using 4x M6 bolt, washer and nut sets as shown

Ensure cut-out edge of bracket faces rear of bar.

Adjust control box until it is approximately 5mm off front of control box recess and tighten all fasteners (9 Nm).

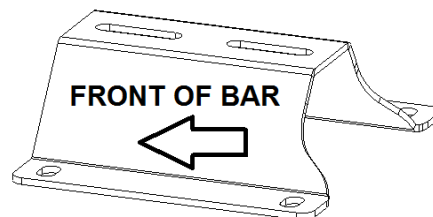

 M6 - 9 Nm.

Brackets set up shown from rear of bar.

Control box cables not shown for clarity.

FITTING PROCEDURE

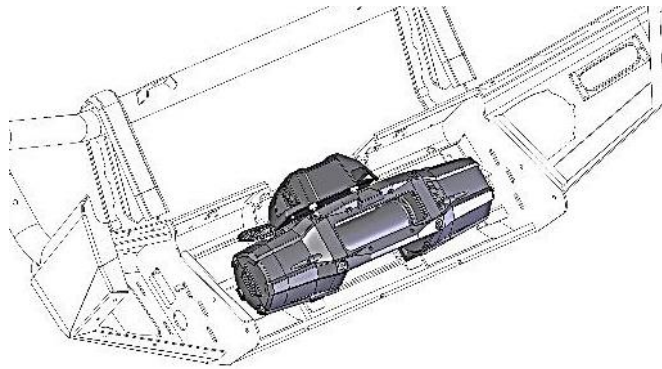

4. Sit the winch in position on the bar's winch cradle.
5. Attach the winch to the bar through the top 2 holes using 2 of the bolts (and any washers) that are supplied with the winch.
6. Level the winch and tighten the bolts.

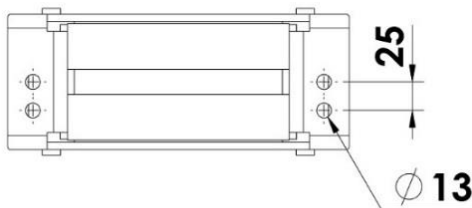
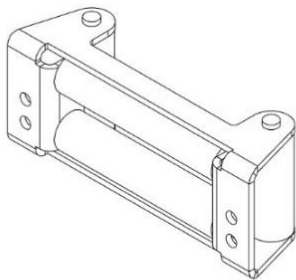

7. If not already done, mark 2 hole positions 25mm below the centre holes as shown in the diagram.
8. Drill 2, $\varnothing 13$ mm holes. De-burr the holes and protect with a zinc rich primer to prevent rust.

Note: Hawse fairleads require kit 3500600

Refer to Hawse fitting kit instructions.

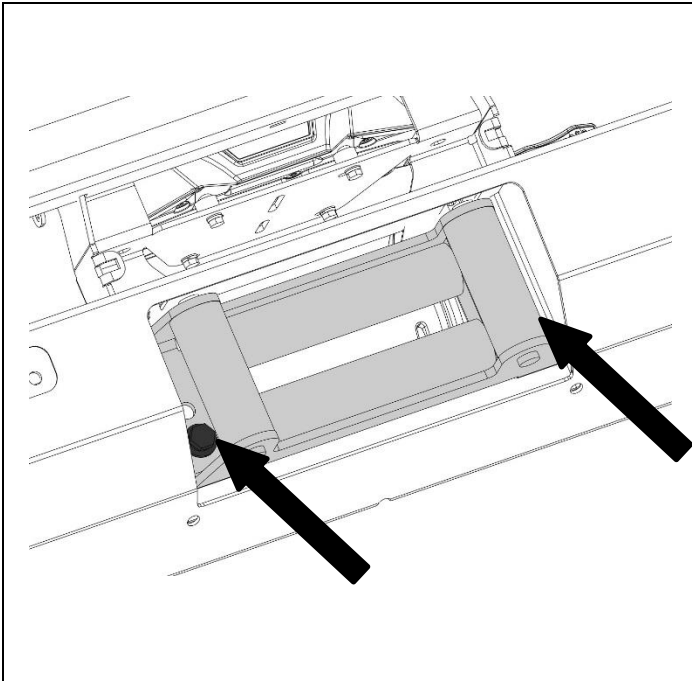

9. Turn the bar over onto the back face.
10. Attach the roller fair lead (RFL) to the bar and winch using the longer hex bolts supplied in this kit and any washers supplied with the winch.

Note 1: To make it easier to get to the bolt holes in the RFL, remove the vertical roller pins and rollers.

Note 2: Some winches will require 3/8" UNC bolts where others will require M10. Both have been supplied in this kit. Please check the threads before proceeding. This can be done by comparing the bolts from this kit with the ones supplied with the winch.



M10- 44 Nm.



3/8th - 44 Nm.

FITTING PROCEDURE

11. Assemble the 2 folding number plate mount brackets together using the M8 hex bolts, Washers, Packers and Nylock Nuts as shown in the diagram below.

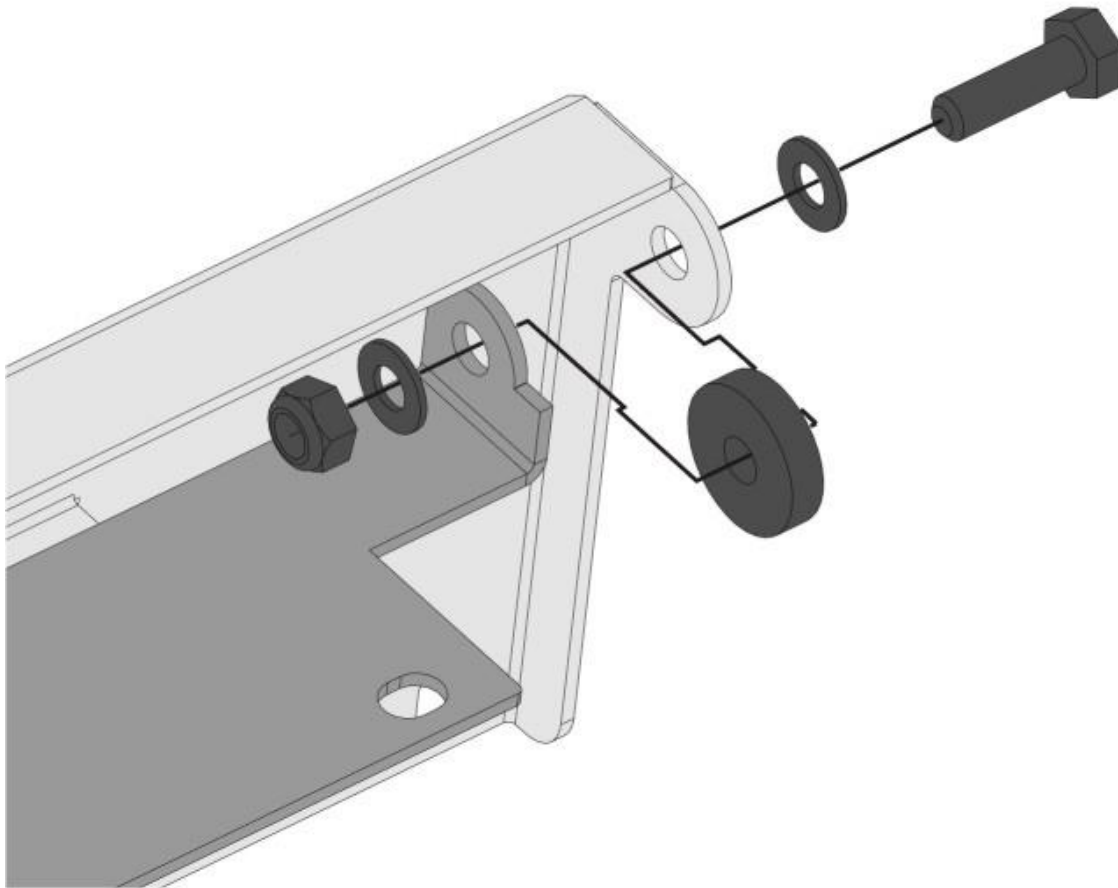

12. Assemble the bracket assembly to the bar using the fasteners supplied with the bar fitting kit. Follow the step in the bars fitting instructions showing the fixed license plate bracket being mounted substituting the folding assembly for the fixed.

 M6 – 9 Nm

13. Ensure all cables are attached as per the winch manufacturer's instructions. Ensure cables are securely attached and cannot rub on any sharp edges.
14. Tidy the cables and secure using cable ties leaving the 2 long power cables free to be connected to the vehicles battery later,

Return to the bar fitment instructions.