



FITTING INSTRUCTIONS

Part Number: **3500910**

Product Description: **ARB LED FOG LIGHT KIT – LRG**

PARTS LIST		
ITEM NUMBER	QTY	DESCRIPTION
1	1	Fog Light LH
2	1	Fog Light RH
3	2	Deutsch connector with terminals and wedge lock

IMPORTANT: These instructions must be read in conjunction with the bull bar instructions. The sequence of fitting the light and surround to the bull bar are specified in the bull bar instructions.

FITTING PROCEDURE

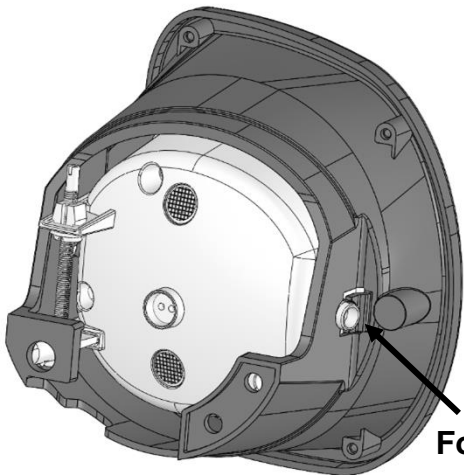

Fog light pin

NOTE: The fog light has a left hand and right hand version. Please ensure you match the correct fog light with its mating fog light surround.

1. Position the fog light in the front of the fog light surround.
2. Insert the fog light pin into the mounting hole of the fog light surround as shown.

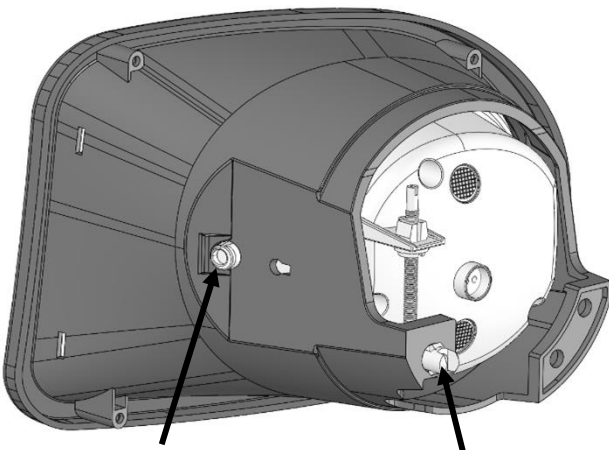

Fog light pin

Adjustment insert

3. Align the adjustment insert with its hole in the fog light surround. Fit the second fog light pin into the remaining mounting hole while feeding the adjustment insert in its hole in the fog light surround.

Ensure that the fog light pin and adjustment insert are secure in their holes.

NOTE: The mounting tab of the fog light surround will flex slightly as the pin slides towards the mounting hole.

FITTING PROCEDURE

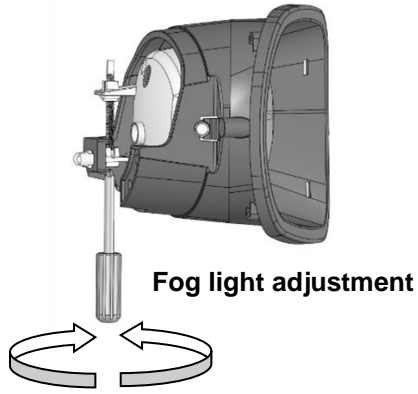

4. To focus the fog light beam downward, turn the adjusting screw in an anti-clockwise direction.
5. To adjust the fog light beam upward, turn the screw in a clockwise direction.

NOTE: Take care when adjusting the fog light that the adjusting screw does not become detached from the screw insert.

Table 1. Fog light polarity

<u>Cable Colour</u>	<u>Pin #</u>	<u>Polarity</u>
Black with White trace	1	Positive (+)
Black	2	Negative (-)

6. If the vehicle was fitted with factory fog lights, remove the factory connectors from the vehicle fog light loom and re-terminated with the Deutsch connectors supplied with this kit. Ensure the polarity of the new connectors is correct as described in Table 1.

Note: Where incandescent fog lights are replaced with LED, a resistor may be necessary. Resistors are available at most automotive electrical stores and should be installed parallel across the positive and negative terminals. This will avoid activation of the vehicle blown globe warning system.

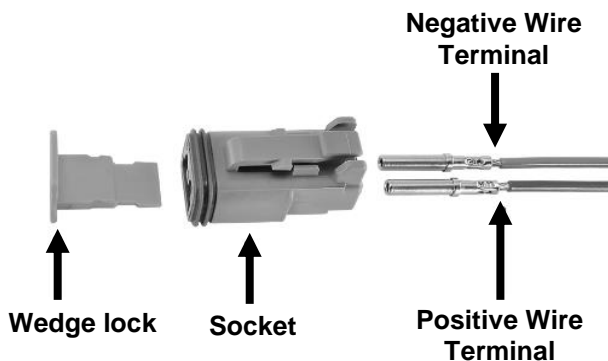

7. If the vehicle was not optioned with factory fog lights, ARB recommends using the ARB wiring loom (#3500520) to connect the fog lights to the vehicle's electrical system. In this case, refer to the instructions included with this loom for wiring instructions.

ARB PRODUCTS WARRANTY AGAINST DEFECTS

ARB warrants the ARB Products against defects in workmanship and materials for the Warranty Period. If defective workmanship or materials become apparent in the Warranty Period, ARB will replace or repair the defective Product. The benefits to the customer given by this warranty are in addition to other rights and remedies of the customer under a law in relation to the goods or services to which the warranty relates.

1. In this warranty:
 - ARB means ARB Corporation Limited (ABN 31 006 708 756) of 42-44 Garden St, Kilsyth Victoria 3137
 - ARB Outlet means an outlet which has been authorised by ARB to sell and fit ARB Products
 - ARB Product means products which ARB manufactures or for which ARB is the exclusive supplier
 - Product Information means the information about the relevant ARB Product which may be contained in any of: documentation provided with the ARB Product, owner's manual, operating manual, service manual or the manufacturer's manual or labels attached to the ARB Product
 - Warranty Period means, in respect of an ARB Product, the period that this warranty against defects applies and which is set out in paragraph 8.
2. To be entitled to claim the warranty, the customer must:
 - a) have the ARB Product fitted in accordance with the Product Information
 - b) carry out normal care and maintenance of the ARB Product, including any required by the Product Information
 - c) provide proof of purchase of the ARB Product
 - d) make the claim in the Warranty Period.
3. The warranty will not apply in circumstances where the defect is caused by:
 - a) unusual, improper or negligent use or misuse of the ARB Product
 - b) incorrect fitting of the ARB Product other than at an ARB Outlet
 - c) use of non-genuine ARB components in or with the ARB Product
 - d) use of the ARB Product outside of the requirements of the Product Information.
4. The procedure for the customer to claim the warranty is:
 - a) return the ARB Product to the nearest ARB Outlet or contact ARB to arrange a time to bring a vehicle fitted with the ARB Product to an ARB Outlet for inspection. Contact details are in paragraph 7 below if further information is required regarding local outlet details
 - b) bring proof of purchase of the ARB Product to the ARB Outlet
 - c) ARB will review the ARB Product and advise whether the conditions of this warranty have been met
5. Where ARB accepts a customer's warranty claim, ARB will rectify any defective workmanship or materials at its own expense.
6. Expenses incurred by the customer in claiming the warranty are to be borne by the customer.
7. This warranty is given by: ARB Corporation Limited 42-44 Garden Street Kilsyth VIC 3137, Australia. Phone: 03 9761 6622. Fax: 03 9721 9090. www.arb.com.au
8. The period within which a defect in the ARB Products must appear if the customer is to be entitled to claim the warranty is 3 years starting on the date of purchase unless:
 - The ARB Product is used in Commercial Use. Commercial Use means use in industry or commerce including (without limitation) use in the mining industry or as a hire vehicle. In this case, the Warranty Period is 1 year
9. The warranty against defects contained in this document replaces any other warranty against defects or voluntary warranty given in relation to the Products. Our goods come with guarantees that cannot be excluded under the Australian Customer Law. You are entitled to a replacement or refund for a major failure and compensation for any other reasonably foreseeable loss or damage. You are also entitled to have the goods repaired or replaced if the goods fail to be of acceptable quality and the failure does not amount to a major failure.