



# FITTING INSTRUCTIONS

Part Number: **3500890**

Product Description: **ARB LED FOG LIGHT KIT – SML**

PARTS LIST		
ITEM NUMBER	QTY	DESCRIPTION
1	2	Fog Light
2	2	Adjusting Screw
3	2	Adjusting Spring
4	2	Plastic Screw Insert
5	2	Deutsch connector with terminals and wedge lock

**IMPORTANT:** These instructions must be read in conjunction with the bull bar instructions. The sequence of fitting the light and surround to the bull bar are specified in the bull bar instructions.

## FITTING PROCEDURE

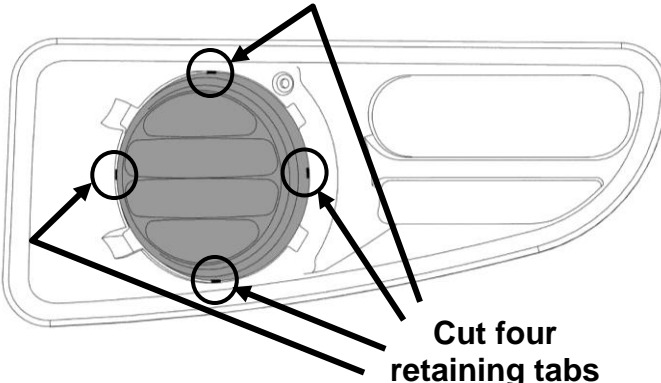
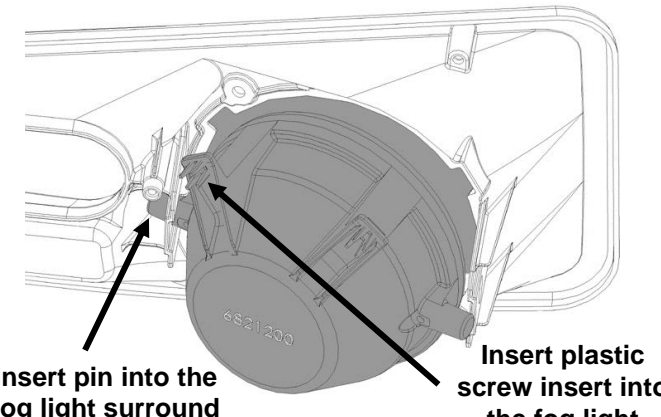
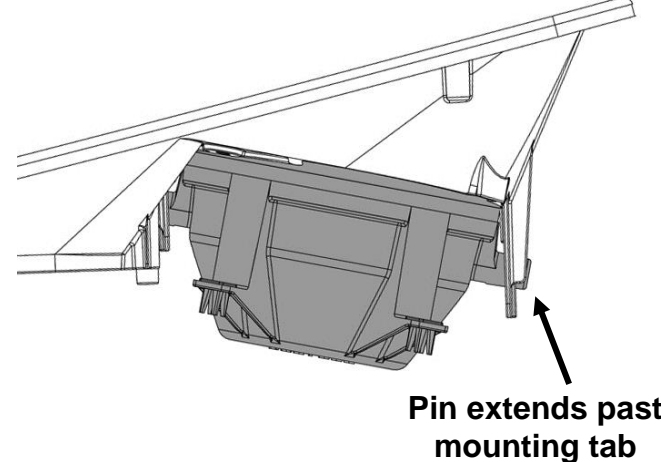
 <p>Cut four retaining tabs</p>	<ol style="list-style-type: none"><li>1. Remove the blanking plate from the fog light surround by cutting through the four retaining tabs with a sharp knife or hacksaw blade.</li><li>2. File or sand any excess plastic protruding past the circular edge of the fog light surround.</li></ol>
 <p>Insert pin into the fog light surround</p> <p>Insert plastic screw insert into the fog light</p>	<ol style="list-style-type: none"><li>3. Insert the plastic screw insert into the fog light. Ensure the plastic screw insert is inserted in the correct side of the fog light, inline with the screw hole in the fog light surround.</li><li>4. Position the fog light behind the fog light surround with the tabs at the top.</li><li>5. Insert one of the fog light pins into the mounting hole in the fog light surround as shown.</li></ol>
 <p>Pin extends past mounting tab</p>	<ol style="list-style-type: none"><li>6. Fit the opposite fog light pin into the remaining mounting hole in the fog light surround.</li></ol> <p>To do this, push the fog light towards the front of the fog light surround until the pin is located in the mounting hole.</p> <p>Ensure that the fog light pin extends at least 3mm past the end of the mounting tab.</p> <p><b>NOTE:</b> The mounting tab of the fog light surround will flex slightly as the pin slides towards the mounting hole.</p>

## FITTING PROCEDURE

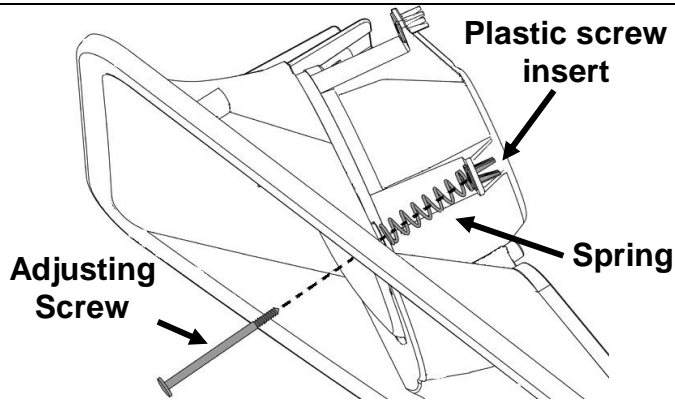

7. Feed the adjusting screw through the hole in the front of the fog light surround.
8. Place a spring over the adjusting screw between the back edge of the fog light surround and the front edge of the plastic screw insert.
9. Thread the adjusting screw into the plastic screw insert of the fog light.

**NOTE: Ensure that there is always a minimum 5mm of screw thread exposed through the back of the plastic screw insert.**

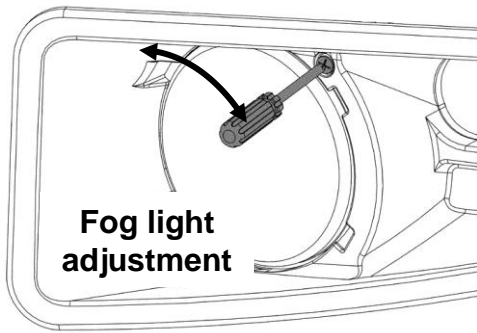

10. Position the vehicle on flat ground and toward a flat surface. Turn the fog lights on and observe the height of the fog beam. Following the steps below, adjust the fog lights ensuring the two beams are at the same height and below the horizontal.
11. To focus the fog light beam downward, turn the adjusting screw in a clockwise direction. To adjust the fog light beam upward, turn the screw in an anticlockwise direction.

**NOTE: Take care when adjusting the fog light that the adjusting screw does not become detached from the plastic screw insert.**

**Table 1. Fog light polarity**

Cable Colour	Polarity
Black with White trace	Positive (+)
Black	Negative (-)

12. If the vehicle was fitted with factory fog lights, remove the factory connectors from the vehicle fog light loom and re-terminated with the Deutsch connectors supplied with this kit. Ensure the polarity of the new connectors is correct as described in Table 1.



13. If the vehicle was not optioned with factory fog lights, ARB recommends using the ARB wiring loom (#3500520) to connect the fog lights to the vehicle's electrical system. In this case, refer to the instructions included with this loom for wiring instructions.

## ARB PRODUCTS WARRANTY AGAINST DEFECTS

ARB warrants the ARB Products against defects in workmanship and materials for the Warranty Period. If defective workmanship or materials become apparent in the Warranty Period, ARB will replace or repair the defective Product. The benefits to the customer given by this warranty are in addition to other rights and remedies of the customer under a law in relation to the goods or services to which the warranty relates.

1. In this warranty:
  - ARB means ARB Corporation Limited (ABN 31 006 708 756) of 42-44 Garden St, Kilsyth Victoria 3137
  - ARB Outlet means an outlet which has been authorised by ARB to sell and fit ARB Products
  - ARB Product means products which ARB manufactures or for which ARB is the exclusive supplier
  - Product Information means the information about the relevant ARB Product which may be contained in any of: documentation provided with the ARB Product, owner's manual, operating manual, service manual or the manufacturer's manual or labels attached to the ARB Product
  - Warranty Period means, in respect of an ARB Product, the period that this warranty against defects applies and which is set out in paragraph 8.
2. To be entitled to claim the warranty, the customer must:
  - a) have the ARB Product fitted in accordance with the Product Information
  - b) carry out normal care and maintenance of the ARB Product, including any required by the Product Information
  - c) provide proof of purchase of the ARB Product
  - d) make the claim in the Warranty Period.
3. The warranty will not apply in circumstances where the defect is caused by:
  - a) unusual, improper or negligent use or misuse of the ARB Product
  - b) incorrect fitting of the ARB Product other than at an ARB Outlet
  - c) use of non-genuine ARB components in or with the ARB Product
  - d) use of the ARB Product outside of the requirements of the Product Information.
4. The procedure for the customer to claim the warranty is:
  - a) return the ARB Product to the nearest ARB Outlet or contact ARB to arrange a time to bring a vehicle fitted with the ARB Product to an ARB Outlet for inspection. Contact details are in paragraph 7 below if further information is required regarding local outlet details
  - b) bring proof of purchase of the ARB Product to the ARB Outlet
  - c) ARB will review the ARB Product and advise whether the conditions of this warranty have been met
5. Where ARB accepts a customer's warranty claim, ARB will rectify any defective workmanship or materials at its own expense.
6. Expenses incurred by the customer in claiming the warranty are to be borne by the customer.
7. This warranty is given by: ARB Corporation Limited 42-44 Garden Street Kilsyth VIC 3137, Australia. Phone: 03 9761 6622. Fax: 03 9721 9090. www.arb.com.au
8. The period within which a defect in the ARB Products must appear if the customer is to be entitled to claim the warranty is 3 years starting on the date of purchase unless:
 

The ARB Product is used in Commercial Use. Commercial Use means use in industry or commerce including (without limitation) use in the mining industry or as a hire vehicle. In this case, the Warranty Period is 1 year
9. The warranty against defects contained in this document replaces any other warranty against defects or voluntary warranty given in relation to the Products.

Our goods come with guarantees that cannot be excluded under the Australian Consumer Law. You are entitled to a replacement or refund for a major failure and compensation for any other reasonably foreseeable loss or damage. You are also entitled to have the goods repaired or replaced if the goods fail to be of acceptable quality and the failure does not amount to a major failure.