



FITTING INSTRUCTIONS

Part Number: **3500610**

Product

Description: **WARN ZEON WIRE ROPE WINCH FITTING KIT.**

Suited to

vehicle/s: **AS NOTED IN CHART ON PAGES 3-4.**

WARNING

NOTE THE FOLLOWING:

- ◆ This product must be installed exactly as per these instructions using only the hardware supplied.
- ◆ In the event of damage to any bull bar component, contact your nearest authorised ARB stockist. Repairs or modifications to the impact absorption system must not be attempted.
- ◆ Do not remove labels from this product (if fitted).
- ◆ This product or its fixing must not be modified in any way.
- ◆ The installation of this product may require the use of specialized tools and/or techniques
- ◆ It is recommended that this product is only installed by trained personnel
- ◆ These instructions are correct as at the publication date. ARB Corporation Ltd. cannot be held responsible for the impact of any changes subsequently made by the vehicle manufacturer
- ◆ During installation, it is the duty of the installer to check correct operation/clearances of all components
- ◆ Work safely at all times
- ◆ Unless otherwise instructed, tighten fasteners to specified torque

ARB 4x4 ACCESSORIES

Corporate Head Office

42-44 Garden St
Kilsyth, Victoria
AUSTRALIA 3137

Tel: +61 (3) 9761 6622
Fax: +61 (3) 9761 6807

Australian enquiries
North & South American enquiries
Other international enquiries

sales@arb.com.au
sales@arbusa.com
exports@arb.com.au

www.arb.com.au

GENERAL CARE AND MAINTENANCE



- As part of any Pre Trip Preparation, or on an annual basis, it is recommended that a thorough visual inspection of the winch is carried out, making sure that all bolts and other components are torqued to the correct specification. Also check that all wiring sheaths, connectors, and fittings are free of damage. Replace any components as necessary. This service can be performed by your local authorized ARB Stockist.

FITTING REQUIREMENTS

REQUIRED TOOLS FOR FITMENT OF PRODUCT:

Basic tool kit	
TORX keys or sockets.	

HAVE AVAILABLE THESE SAFETY ITEMS WHEN FITTING PRODUCT:

Protective eyewear		Hearing protection	
--------------------	--	--------------------	--

NOTE: 'WARNING' notes in the fitting procedure relate to OHS situations, where to avoid a potentially hazardous situation it is suggested that protective safety gear be worn or a safe work procedure be employed. If these notes and warnings are not heeded, injury may result.

FASTENER TORQUE SETTINGS:

SIZE	Torque Nm	Torque lbft
M6	9Nm	7lbft
M8	22Nm	16lbft
M10	44Nm	32lbft
M12	77Nm	57lbft

PARTS LISTING

APPLICATION.	PART NO.	QTY	DESCRIPTION
WINCH TO BAR	6250013	4	ALUMINIUM SPACER 25MM
	6250014	4	ALUMINIUM SPACER 15MM
	6151091	2	BOLT M10 X 60
	6151614	4	BOLT M10 X 70
	6151217	2	BOLT M10 X 50
	6151615	2	BOLT M10 X 80
	4581040	2	WASHER FLAT M10 X 25 X 3
	4584296	2	WASHER FLAT M10 X 30 X 5
CONTROL BOX TO BAR	3751884	1	MOUNT CONTROL BOX
	6151402	4	BOLT M6 X 16
	4584295	4	WASHER FLAT M6
	6821112	9	CABLE TIES
	6821258	3	SPLIT TUBING 13MM X 440

PLEASE NOTE: Control box must be removed from ZEON for all bars except those that suit a high mount winch.

WARN RELOCATION KIT W89965 will be required for all bars except those to suit high mount winches.

SPACING AND FAIRLEAD TYPES. GUIDE ONLY.

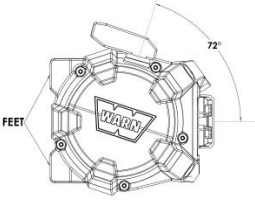
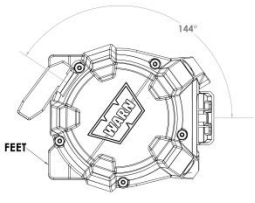
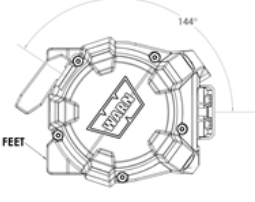
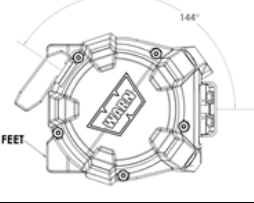
VEHICLE.	SPACING.	HAWSE.	HANDLE ROTATION.
Y62 PATROL	15MM	CENTRE	
Y61 PATROL	15MM	CENTRE	
Y61 COMMERCIAL	15MM	OFFSET	
NISSAN D40 (WILL NOT FIT DIESEL V6)	NO SPACING	OFFSET	

SPACING AND FAIRLEAD TYPES. GUIDE ONLY.

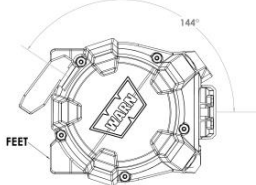
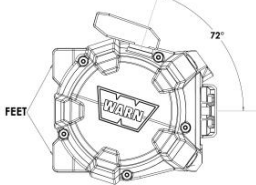
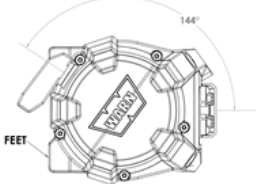
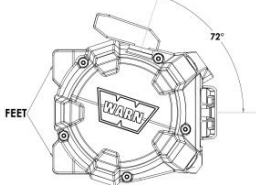
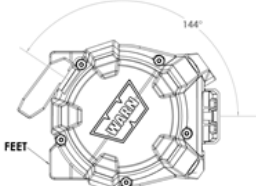
VEHICLE.	SPACING.	HAWSE.	HANDLE ROTATION.
TOYOTA LC200	25MM	CENTRE	
TOYOTA LC70	NO SPACING (15MM FOR COMMERCIAL ONLY)	OFFSET	
TOYOTA 150 PRADO	NO SPACING	CENTRE	
TOYOTA TACOMA	NO SPACING	OFFSET	
ISUZU DMAX HOLDEN COLORADO	15MM	OFFSET	

FITTING PROCEDURE



1. From the instructions provided with the bullbar determine whether you are fitting to offset or centred lower holes. If stated so in the bullbar instructions drill new holes in the roller fairlead.



2. Use above chart as a guide to positioning the clutch handle. Generally they are in the 72° or 144° anti-clockwise position. Remove the gearbox fasteners and rotate the gearbox to the required position. **DO NOT REMOVE GEARBOX COMPLETELY.** Tighten when done.
3. Place 4 x M10 Warn flange nuts into winch as shown in the ZEON manual before fitting to bar.

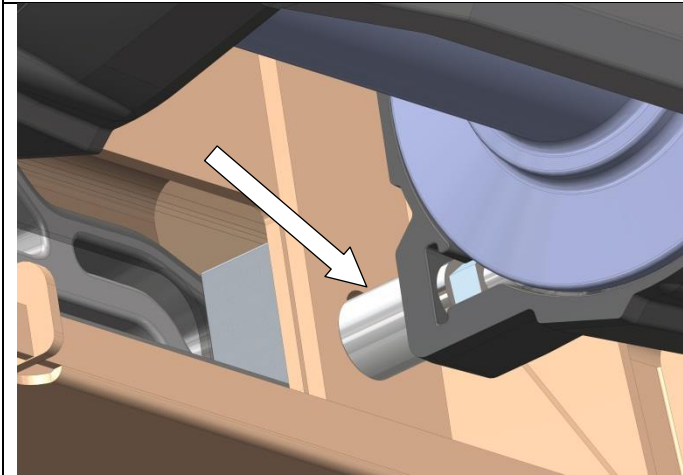

4. Using the above chart as a guide determine whether the spacing will be 0mm, 15mm or 25mm. If using spacers place them between the winch feet and mount on bullbar.

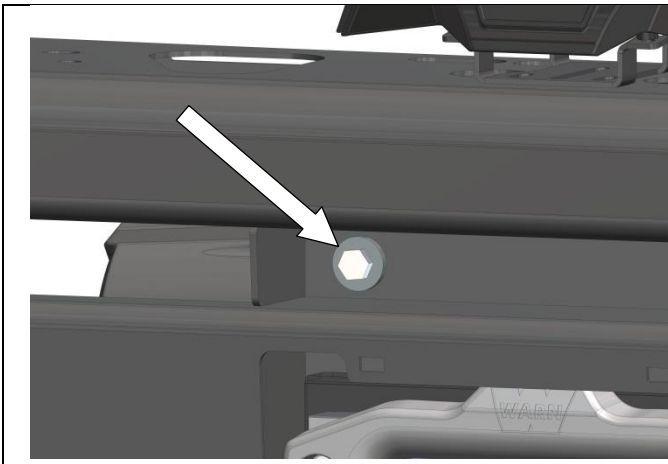

5. Secure Top mounts using the bolt lengths and or washers shown below.
 No spacing – Warn M10 x 40 flange bolts
 15mm spacing – 2 x M10 x 60 bolts and 2 x M10 x 5mm thick flat washers
 25mm spacing – 2 x M10 x 70 bolts and 2 x M10 x 5mm thick washers.
 Do not tighten.

FITTING PROCEDURE

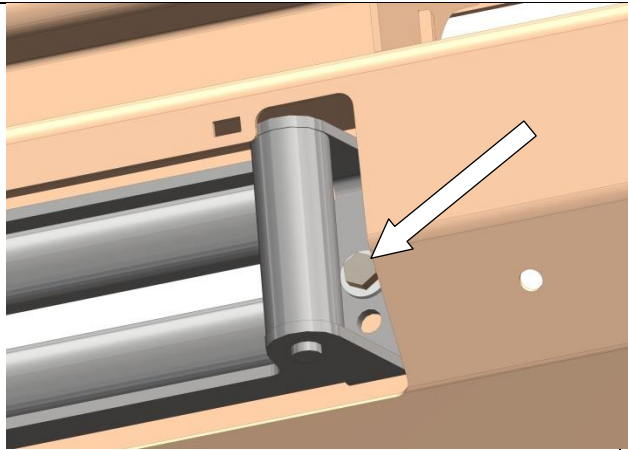

6. Follow the steps in the bullbar fitting instructions as to how to prepare the roller fairlead for installation. Secure lower mounts to bar using 2 x M10 x 3mm thick washers and bolt lengths shown below. Tighten all bolts when done.

- No spacing – 2 x M10 x 50 bolts
- 15mm spacing – 2 x M10 x 70 bolts
- 25mm spacing – 2 x M10 x 80 bolts

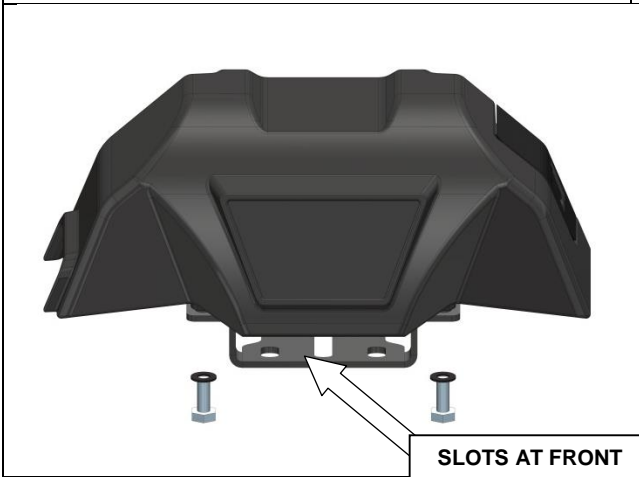

SLOTS AT FRONT

7. Install the longer cables to the control box as per the instructions in the Warn relocation kit.
8. Install new mounting bracket to control box using 4 x M6 x 16 bolts and flat washers.

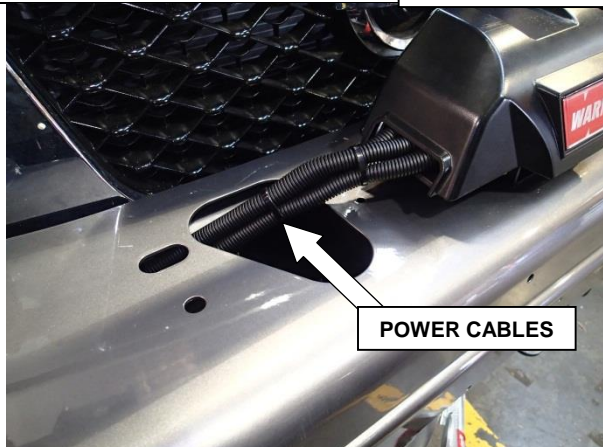

POWER CABLES

9. Place the sections of 13mm dia split tubing on the three black cables coming out of the control box.
10. Carefully rout cables through top pan and fasten box to bar using M8 fasteners provided in bullbar fitting kit. Cable tie leads tightly trying to avoid sharp edges.
11. Attach power cables to Winch following the Warn instructions.



FITTED PRODUCT

