



FITTING INSTRUCTIONS

Part Number: **3448530**
Product Description: **SUMMIT COMBAR DMAX MY17| AF20 8-10**
Suited to vehicle/s: **ISUZU DMAX 2/17 ON**
Optional Fitting Kit:
3500530 - ARB Fog Light Loom
3500680 - Fog Lamp Housing Clear Lens Kit
3500590 - Fog Light Kit (LH&RH Lights)
3500720 - SUMMIT BAR WINCH INSTALL KIT WITH NP BRKT
3500700 - Anti Reflective Tape Kit

WARNING

REGARDING VEHICLES EQUIPPED WITH SRS AIRBAG;

When installed in accordance with these instructions, the front protection bar does not affect operation of the SRS airbag.

ALSO, NOTE THE FOLLOWING:

- ◆ This product must be installed exactly as per these instructions using only the hardware supplied.
- ◆ In the event of damage to any bull bar component, contact your nearest authorised ARB stockist. Repairs or modifications to the impact absorption system must not be attempted.
- ◆ Do not use this product for any vehicle make or model, other than those specified by ARB.
- ◆ Do not remove labels from this bull bar.
- ◆ This product or its fixing must not be modified in any way.
- ◆ The installation of this product may require the use of specialized tools and/or techniques
- ◆ It is recommended that this product is only installed by trained personnel
- ◆ These instructions are correct as at the publication date. ARB Corporation Ltd. cannot be held responsible for the impact of any changes subsequently made by the vehicle manufacturer
- ◆ During installation, it is the duty of the installer to check correct operation/clearances of all components
- ◆ Work safely at all times
- ◆ Unless otherwise instructed, tighten fasteners to specified torque

ARB 4x4 ACCESSORIES

Corporate Head Office

42-44 Garden St
Kilsyth, Victoria
AUSTRALIA 3137

Tel: +61 (3) 9761 6622
Fax: +61 (3) 9761 6807

Australian enquiries
North & South American enquiries
Other international enquiries

sales@arb.com.au
sales@arbusa.com
exports@arb.com.au

www.arb.com.au

GENERAL CARE AND MAINTENANCE

By choosing an ARB Bar, you have bought a product that is one of the most sought after 4WD products in the world. Your bar is a properly engineered, reliable, quality accessory that represents excellent value. To keep your bar in original condition it is important to care and maintain it following these recommendations:



- Prior to exposure to the weather your bar should be treated to a Carnauba based polish on all exposed surfaces. It is recommended that this is performed on a six monthly basis or following exposure to salt, mud, sand or other contaminants.
- As part of any Pre Trip Preparation, or on an annual basis, it is recommended that a thorough visual inspection of the bar is carried out, making sure that all bolts and other components are torqued to the correct specification. Also check that all wiring sheaths, connectors, and fittings are free of damage. Replace any components as necessary. This service can be performed by your local authorized ARB Stockist.

FITTING REQUIREMENTS

REQUIRED TOOLS FOR FITMENT OF PRODUCT:

Metric socket and spanner sets 8-25mm range	External Circlip pliers
Screwdrivers, Philips and Flat blade	Oscillating Multitool with blade for plastic cutting
Short Body/Right Angled Power Drill	Dia 7.0mm (5/16") and 10.5mm (25/64") drill bits
Torque Wrench (9-102Nm)	Marking pen
Half round file	Soft Hammer
Metric hex&torx key set	Loctite© 262 or equiv.
Wide masking tape (low tack)	Angle Grinder with Disc for metal cutting
Small Spirit Level	Tape Measure & 2 x 300mm rulers
Torx keys	Paint black fast drying

HAVE AVAILABLE THESE SAFETY ITEMS WHEN FITTING PRODUCT:

Protective eyewear		Hearing protection	
--------------------	---	--------------------	---

NOTE: 'WARNING' notes in the fitting procedure relate to OHS situations, where to avoid a potentially hazardous situation it is suggested that protective safety gear be worn or a safe work procedure be employed. If these notes and warnings are not heeded, injury may result.

FASTENER TORQUE SETTINGS:

SIZE	Torque Nm	Torque lbft
M6	9Nm	7lbft
M8	22Nm	16lbft
M10	44Nm	32lbft
M12	77Nm	57lbft

PARTS LISTING

APPLICATION.	PART NO.	QTY	DESCRIPTION
PREPARE VEHICLE	3788096	1	TEMPLATE INNER RAIL
	3788097	1	TEMPLATE OUTER RAIL
MOUNT TO VEHICLE	3759054R	1	RH MOUNT COLORADO
	3759054L	1	LH MOUNT COLORADO
	3194385	2	PLATE TAPPED COLORADO
	6821279	2	WIRE 1.25mm GALVANISED 500mm LONG
	4581083	8	WASHER FLAT M10 x 21 x 2
	4581048	4	WASHER SPRING M10
	6151357	4	BOLT SEMS M10 x 30 GD 8.8
	6151381	4	BOLT M10 x 80
	4721558	4	TUBE CRUSH HILUX B/BAR
	3194384	2	PLATE RECT WASHER COLORADO
	6151026	4	NUT M10 x 1.5
	5848393	6	PACKER UPRIGHT COLORADO
	6151207	4	BOLT M6 x 25
	6151128	4	NUT FLANGE M6
4581082	4	WASHER FLAT M6 BLACK	
BAR TO VEHICLE	4581011	4	WASHER FLAT M12
	6151340	4	BOLT M12 x 50
	4581050	4	WASHER SPRING 1/2
	6151428	4	FLANGE NUT M12 X1.75 ZP
	6151542	4	SCREW SEMS M10 x 40 X1.5 ZP
	6151321	4	NUT FLANGE M10
BUFFERS, INDICATORS AND FOG LIGHTS TO BAR	3500880	1	GRILLE SPLIT PAN KIT
	5100200	1	BUFF KIT 2PCE FRONT SECTION KIT
	5100210	1	BUFF KIT 2PCE REAR UPRIGHT KIT
	6821287	1	LAMP LED INDICATER CLEARANCE KIT
	3163082	1	SURROUND ARB FOGLIGHT KIT
	6821116	4	GROMMET NYLON SNAP IN TYPE
	5848428	4	SHIM OVER RIDER 1.6mm
NUMBER PLATE TO BULL BAR	6821189	2	GROMMET ROUND
	6151384	2	SCREW SELF TAPPING PAN HEAD
	6151213	3	BOLT M6 x 1.0 x 20mm GD 8.8 BZ
	3759488	1	BRACKET LIC PLATE FIXED LARGE RAD
	4581287	3	WASHER SPRING M6 x 2.5 x 1.6 BZ
	4584295	3	WASHER FLAT M6 x 12 x 1.3 BZ
	6151128	3	NUT FLANGE M6 x 1.0 ZP
FIT WINCH COVER PANEL	6522985	1	PRESS FORM WINCH COVER PANEL
	6151213	4	BOLT M6 x 1.0 x 20 Gd8.8 BZ
	4581287	4	WASHER SPRING M6 x 2.5 x 1.6 BLK ZN
	4584295	4	WASHER FLAT M6 X 13 X 1.6 BLK ZN
	6151128	4	NUT FLANGE M6 x 1.0 ZP
MOUNT BRACE & LOWER STONE GUARD	3750149	1	BRKT BRACE DMAX SUMMIT
	6523194	1	PANEL STONE SHIELD DMAX
	6151357	4	BOLT SEMS M10 x 30 GD 8.8
	6151321	4	NUT FLANGE M10
	6151301	5	NUT CAGED M8
	6151234	5	BOLT M8 x 1.25 x 25 GD 8.8 BP
	4581047	5	WASHER SPRING M8 BZ
	4581303	5	WASHER FLAT PANEL M8X25X3 BZ
WING UNDER PANELS	6523193R&L	1 PR	PANEL WING DMAX
	6151300	8	CAGE NUT M6
	6151443	8	SCREW BTN HD M6 x 20 BZ
	4581082	8	WASHER FLAT M6 x 20 BZ
	4581287	8	WASHER SPRING M6 BZ
	6151234	2	BOLT M8 x 25 LONG BZ
	4581303	2	WASHER FLAT PANEL M8X 25X3mm BZ
	4581047	2	WASHER SPRING M8 BZ
	6151132	2	NUT FLANGE M8
MISCELLANEOUS	6191025	1	EXTRUSION PINCH WELD 480mm
	180302	4	CABLE TIE 4.8 X 180 BLACK
	3789693	1	TEMPLATE BUMPER COLORADO

FITTING PROCEDURE



1. Read these instructions thoroughly before starting.
2. Remove 2 bumper retaining screws at the wheel liner (1 per side).

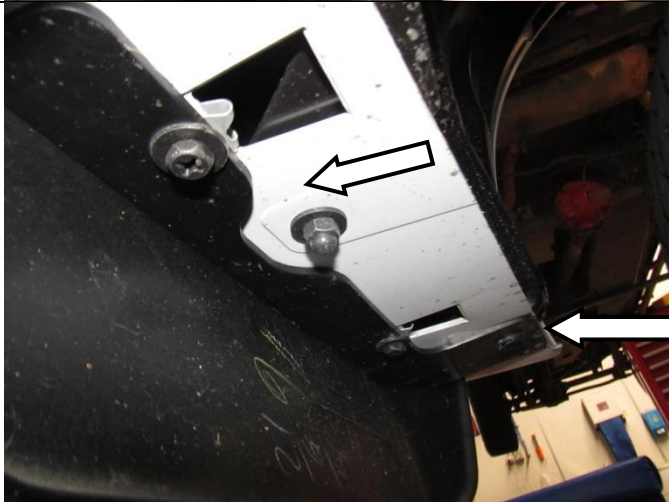

3. Remove the bumper retaining screws and scrivenets from underneath the bumper.



4. Remove and retain the number plate from the bumper.
5. If the vehicle has fog lights fitted disconnect the right and left hand fog light looms.



GRILLE REMOVED FOR CLARITY, THIS IS NOT REQUIRED

6. Cover the vehicle bumper bar with protective low tack tape in the regions where it is to be trimmed as shown adjacent.



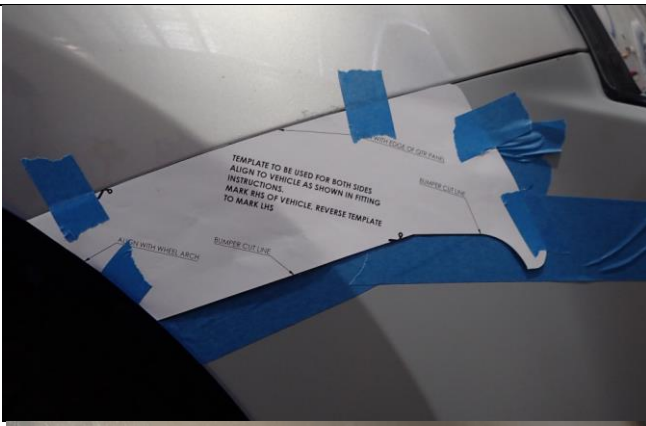

7. Cut the A4 paper template along identified cutting line.

Fasten the template to the RH rear corner of the bumper with tape. Ensure the template is accurately positioned and flush with the upper rear edge of the bumper.

Use a black marker to mark up the bumper cut line.

8. Use the same template and mark up the bumper cut lines on the LH rear corner of the bumper.



9. Using a felt tipped marker, draw a line along the lower edge of the bumper, 10mm below where the grille is located as shown.

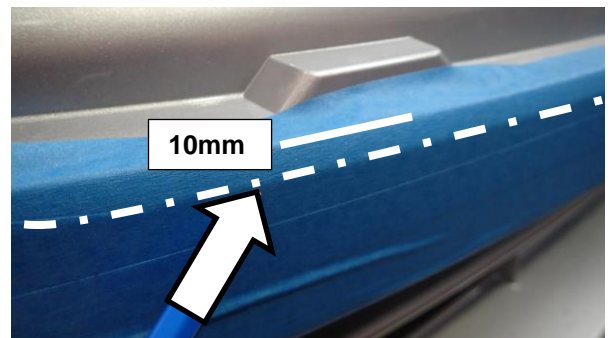

10. On the RHS of the vehicle, using a felt tipped marker and 1m ruler, connect the line below the grille made in the previous step to the edge of the line made from the template with a straight diagonal line as shown.

Note: Cut line may run across top section of fog light housing



Note: Cut line may run across top section of fog light housing

11. Repeat for LHS.



GRILLE REMOVED FOR CLARITY, THIS IS NOT REQUIRED

12. Using an oscillating multitool cut along the line marked in previous steps to remove the lower section of the bumper.

HINT: If fog light housing is difficult to cut, remove from bumper.

13. Remove low tack tape and carefully tidy cut edges with file.



14. Cut pinch weld extrusion in half and apply to outer cut edges of bumper as shown adjacent.

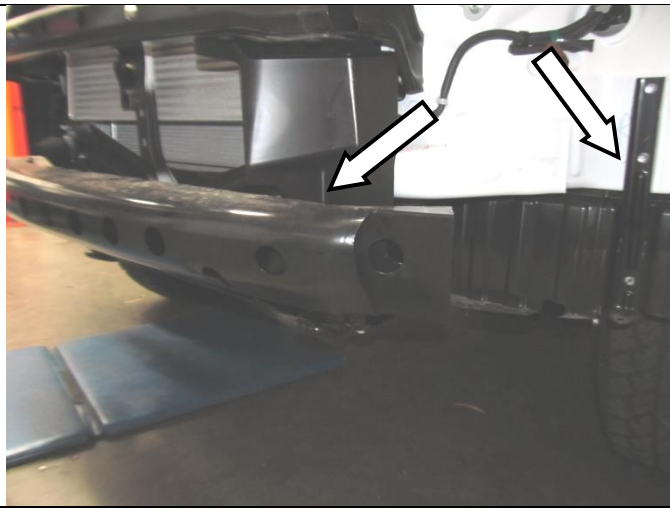

15. Unbolt the RH & LH wheel liner retaining brackets.
16. Remove the lower bumper reinforcement beam using a 14mm socket.
 - 4 hex bolts fastening the beam to the vehicle chassis rails (Retain 1 for step 26)
 - 3 hex bolts fastening the stone guard to the lower bumper reinforcement beam



17. Remove left and right steel brackets for retaining wheel arch liner.



18. Using a flat bladed screw driver or similar gently pry off both left and right air deflectors, retain for later use.

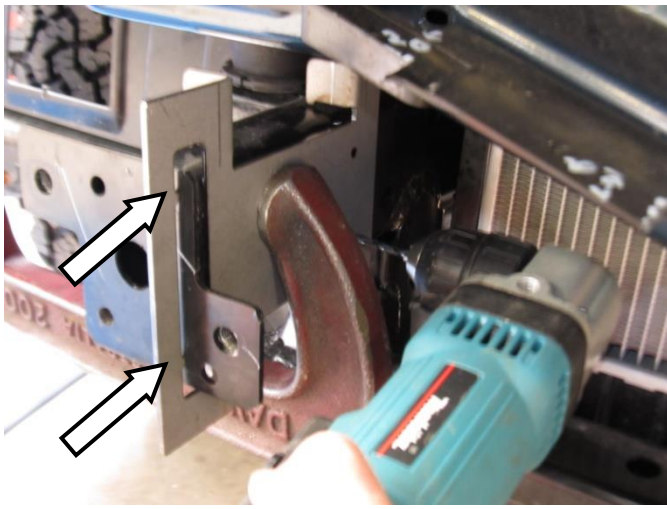

Warning: Drilling operations can result in flying metal debris, safety glasses should be worn.

19. Clamp the inner chassis drilling template, identifiable with an "I" cut through the centre of this part, to the inside face of the RH chassis rail.

ENSURE THE LOCATING DATUMS CONTACT THE FRONT CHASSIS FLANGE. ENSURE THE TEMPLATE IS SITTING CENTRALLY ON THE CHASSIS RAIL, IN THE VERTICAL DIRECTION, BY CHECKING THE CLEARANCE BETWEEN THE UPPER AND LOWER LOCATING TABS AND THE CHASSIS RAIL.

Once the template is positioned accurately on the chassis rail use a right angle drill to drill two Ø4mm pilot holes through the inner wall of the chassis rail.

DO NOT DRILL STRAIGHT THROUGH THE OUTER WALL OF THE CHASSIS RAIL NOW.

NOTE: If you do not have a right angle drill a right angle drill attachment can be bought from a hardware store.

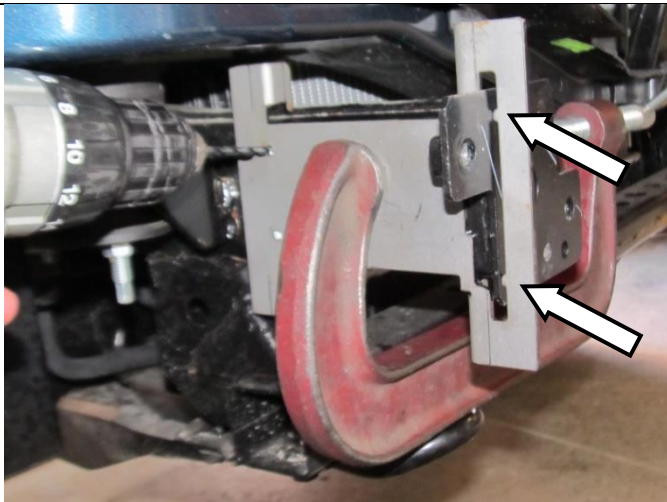

Warning: Drilling operations can result in flying metal debris, safety glasses should be worn.

20. Clamp the outer chassis drilling template, identifiable with an "O" cut through the centre of this part, to the outside face of the RH chassis rail.

ENSURE THE LOCATING DATUMS CONTACT THE FRONT CHASSIS FLANGE. ENSURE THE TEMPLATE IS SITTING CENTRALLY ON THE CHASSIS RAIL, IN THE VERTICAL DIRECTION, BY CHECKING THE CLEARANCE BETWEEN THE UPPER AND LOWER LOCATING TABS AND THE CHASSIS RAIL.

Once the template is positioned accurately on the chassis rail drill the two Ø4mm pilot holes through the outer wall of the chassis rail.

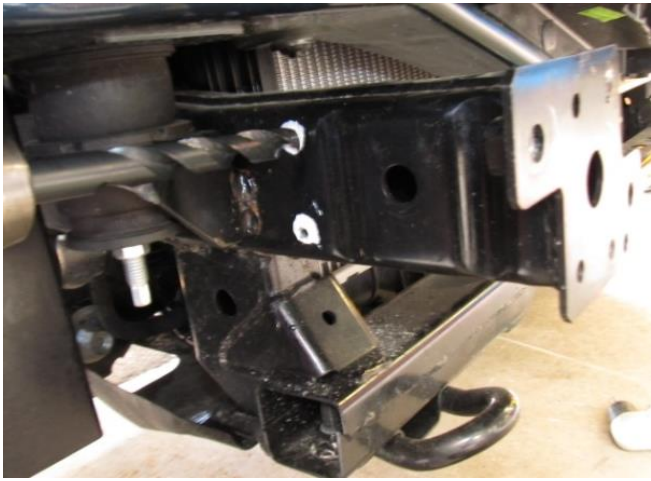

21. Drill two Ø13mm holes through the outer wall of the chassis rail only.

DO NOT DRILL STRAIGHT THROUGH THE INNER WALL OF THE CHASSIS RAIL NOW.



Warning: Drilling operations can result in flying metal debris, safety glasses should be worn.



Warning: Drilling operations can result in flying metal debris, safety glasses should be worn.

22. Replace the Ø13mm drill bit with a Ø10.5mm drill bit and pass the drill through the Ø13mm holes.

USE A SECOND PERSON TO WATCH AND ENSURE THE DRILL IS LOCATED CORRECTLY ON THE Ø4mm PILOT HOLES, ON THE INNER WALL OF THE CHASSIS RAIL, DRILLED AT STEP 19.

IT IS CRITICAL THAT THESE HOLES ARE ACCURATELY LOCATED.

Drill two Ø10.5mm holes through the inner wall of the chassis rail.



23. Paint all drilled holes with rust inhibiting paint.

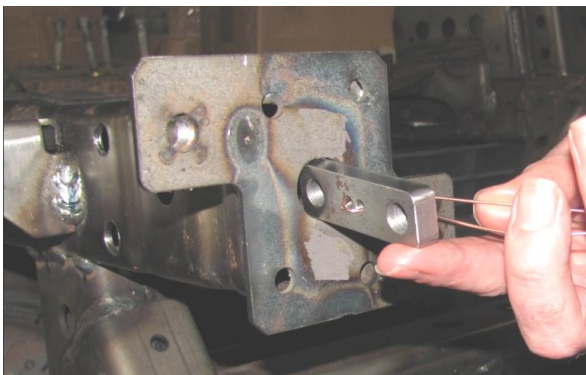

24. Insert the nut plate, from the bull-bar fitting kit, through the front flange of the chassis rail with the wire attached.

ENSURE THE WIRE REMAINS ATTACHED TO THE NUT PLATE AND PROTRUDES FROM THE CHASSIS RAIL.

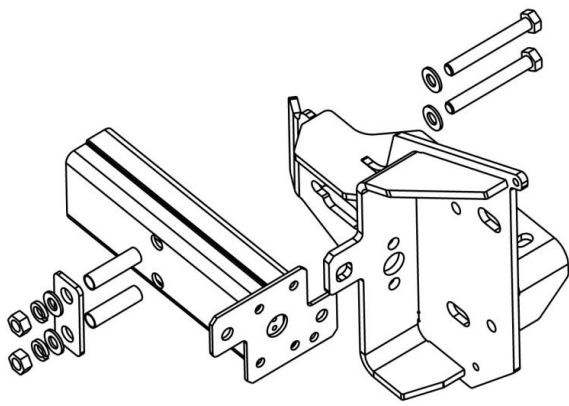

25. Loosely fit the right hand bull-bar mount to the chassis rail using the: M10 x 80 bolts (2 off), flat washers (4 off), crush tubes (2 off), rectangular plate (1 off), spring washers (2 off) and hex nuts (2 off) from the bull-bar fitting kit.

Ensure these bolts are orientated as shown in the adjacent image with the head of the bolt on the inside of the chassis rail.



26. Re-use one of the chassis bolts, removed at step 16, to firmly locate the bull-bar mount bracket to the chassis.

Ensure the mount fits well and in-line with the chassis flange.

NOTE: This bolt will be removed prior to bar fitment.



27. Using an accurate spirit level, make sure the mounting face is vertical.

Also ensure that the mount is flat against the chassis flange.

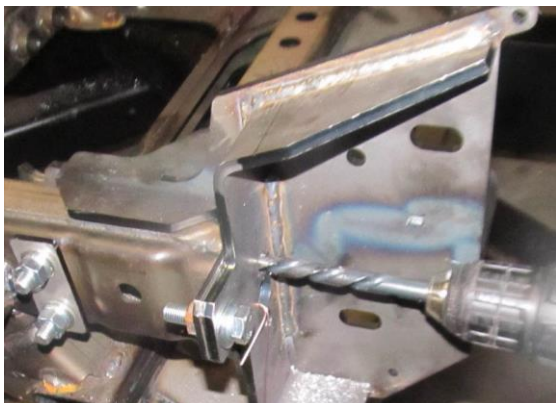

28. Use a punch to mark the two holes in the front of the chassis rail.

Drill two $\text{\O}4\text{mm}$ pilot holes. Next open these holes with a $\text{\O}10.5\text{mm}$ drill bit.

Paint these drilled holes with rust inhibiting paint.



Warning: Drilling operations can result in flying metal debris, safety glasses should be worn.

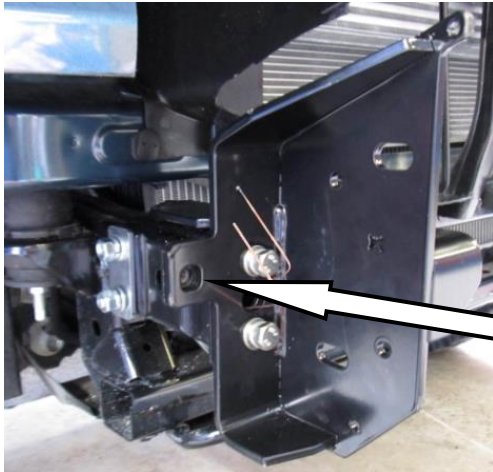

29. Fasten the two M10 x 30 SEMS bolts to the nut plate inserted in the chassis at step 24. Use the wire, shown in the adjacent image, to correctly position the nut plate.

Tighten the two M10 x 30 hex bolts.

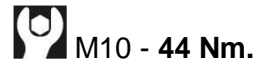

M10 - 44 Nm.

Tighten the two M10 x 80 hex bolts (fit at step 45).

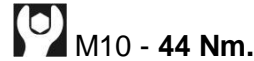

M10 - 44 Nm.

Remove the chassis bolt which was fastened at step 26.

Note: DO NOT REMOVE THE WIRE USED TO POSITION THE NUT PLATE AS IT MAY BE REQUIRED IN THE FUTURE IF THESE MOUNTS ARE REMOVED.

Repeat steps 19 to 29 for the left hand chassis mount.



30. Use a tape to measure the distance between the two outer faces of the bull-bar mounts.

- The nominal design dimension is 722mm. This may differ, however, due to vehicle chassis variation.

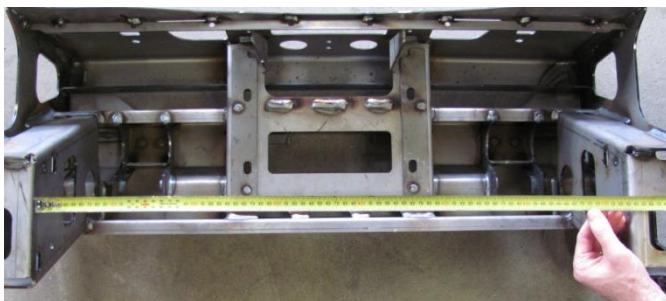

31. Measure the distance between the bull-bar mounting faces.

- The nominal design dimension is 736mm.

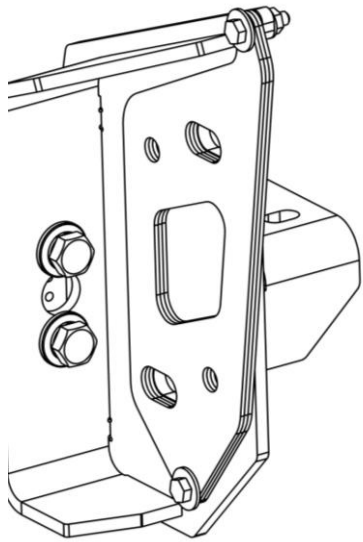

32. Fit an equal number of 2.5mm packers to the RH and LH mounts as required with the M6 x 25 bolts (2 per mount), flat washers and flange nuts.
- The total clearance between the bull-bar mounting faces and the mounts should be roughly 1-2mm.



33. Re-fit the air deflectors removed in previous steps by flexing the lower inner edge around the bull bar mount.



LED INDICATOR/CLEARANCE LOOM	
Cable Colour	Function
RED	CLEARANCE (+)
GREEN	INDICATOR (+)
BLACK	GROUND (-)
VEHICLE LOOM RHS	
Colour	Function
BROWN/RED	CLEARANCE (+)
GREEN	INDICATOR (+)
BLACK	GROUND (-)
VEHICLE LOOM LHS	
Colour	Function
BROWN/YELLOW	CLEARANCE (+)
YELLOW	INDICATOR (+)
BLACK	GROUND (-)

34. Unplug the RH and LH indicator and clearance light plugs from the rear of the head lights. Run the looms out through the hole in the sheet metal for easy access.
35. Using supplied scotch locks, connect the LED Indicator/clearance light looms as per table below:



FITTING PROCEDURE

Note: If fitting a winch proceed using fitting instructions 3789337 supplied with 3500720 winch install kit. Once the winch is fitted please continue to step 39. If no winch is being fitted continue from step 36.

36. Slide the winch cover panel from the bottom up until it is level with the top face of the bar.
37. Fit the winch cover panel to the bar using 4 x M6 x 20 hex bolts, spring washers, flat washers and flange nuts.

Warning: Be careful not to scratch the finish of the winch cover panel.

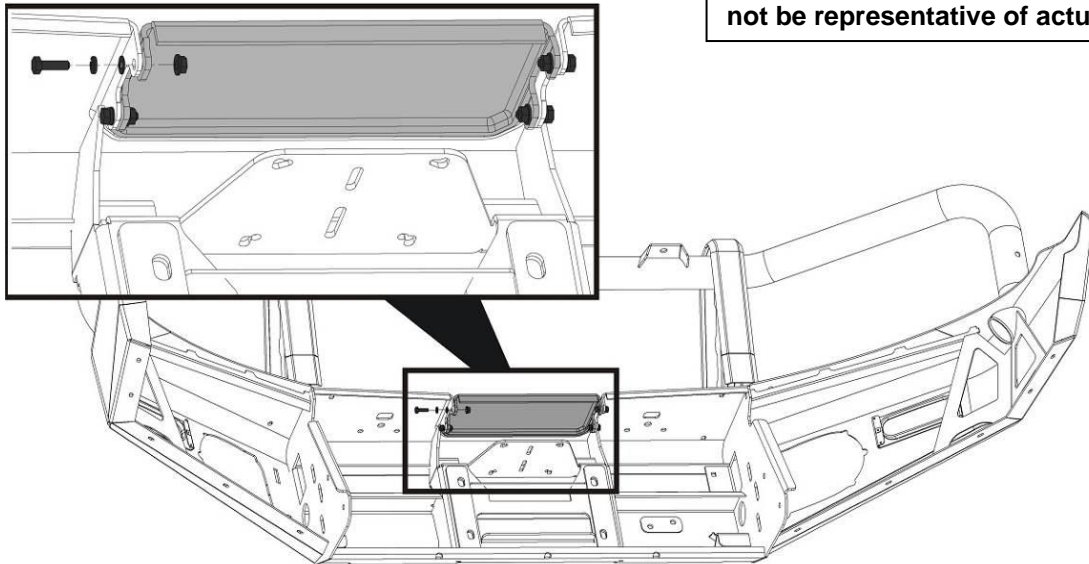

38. Fit the number plate bracket to the top face of the lower-centre pan on the bar using 3 x M6 x 20 hex bolts, spring washers, flat washers and flange nuts.

Note: If you are fitting a winch, fit the folding number plate bracket supplied in winch install kit "3500720 WINCH INSTALL KIT" – See fitting instructions 3789337

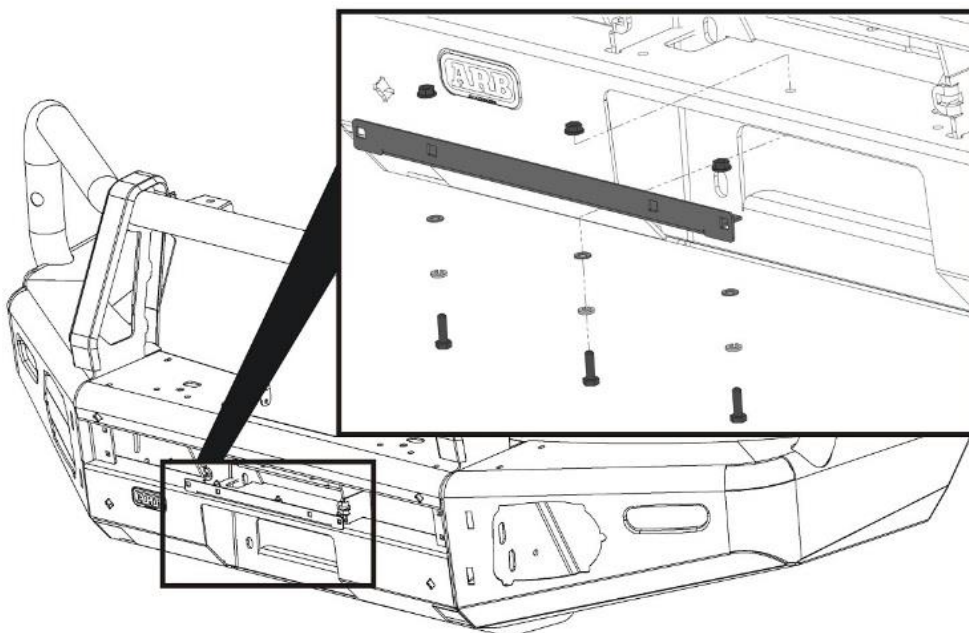

Note: The following steps show the fitment of the plastic moulded parts. The mouldings are supplied in kits along with all fasteners required for fitment. It is important that the fasteners supplied with each kit are only used for the mouldings from the same kit. The kits included in this bar kit are as follows:

39. Layout the contents of each of the following kits ensuring the contents are kept separate from each other.

Kit No.	Description
5100200	BUFF KIT 2PCE FRONT SECTION
5100210	BUFF KIT 2PCE REAR UPRIGHT BAR
3500880	SPLIT PAN MESH KIT
3163082	FOG SURROUND KIT

40. Mark the grille panel to be cut at the 840mm marks at each end on the back face.

Note: When marked, double check the measurement with a measuring tool.

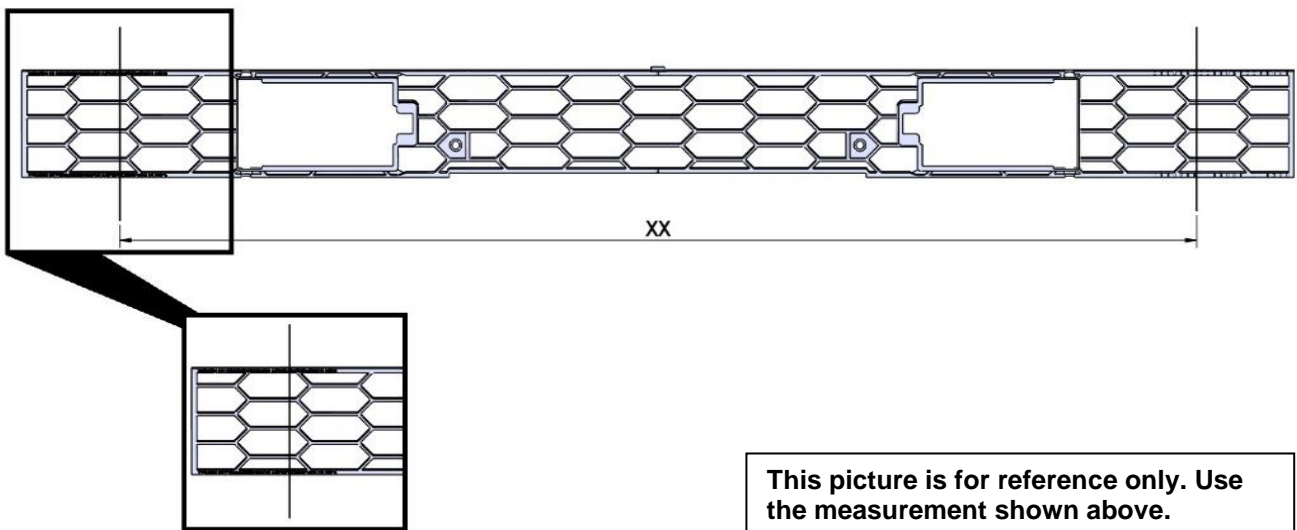

41. Use a hacksaw or similar cutting tool to carefully cut the grille panel at the positions marked in the step above.

42. Discard the off cuts and clean up the cut edges using a file or sandpaper.

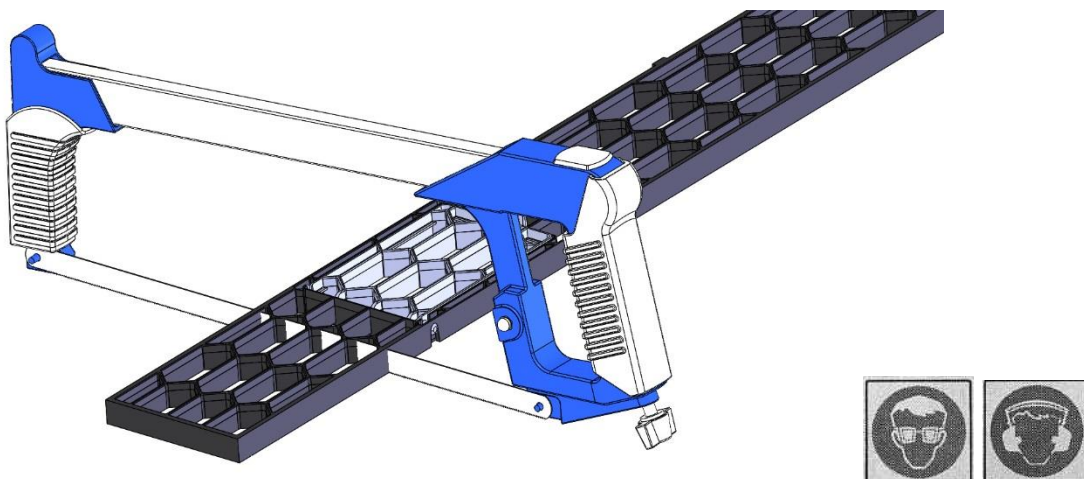

43. Insert the 6 x plastic grommets into the 6 square holes in the front face of the bar.
44. Insert the grille into the bar so that the hatches open outward (facing the front of the bar).
45. Attach the grille to the centre of the bar using the short screws into the grommets fitted above.
46. Attach the ends of the grille to the bar using the longer screws, through the clamp plates into the remaining grommets.

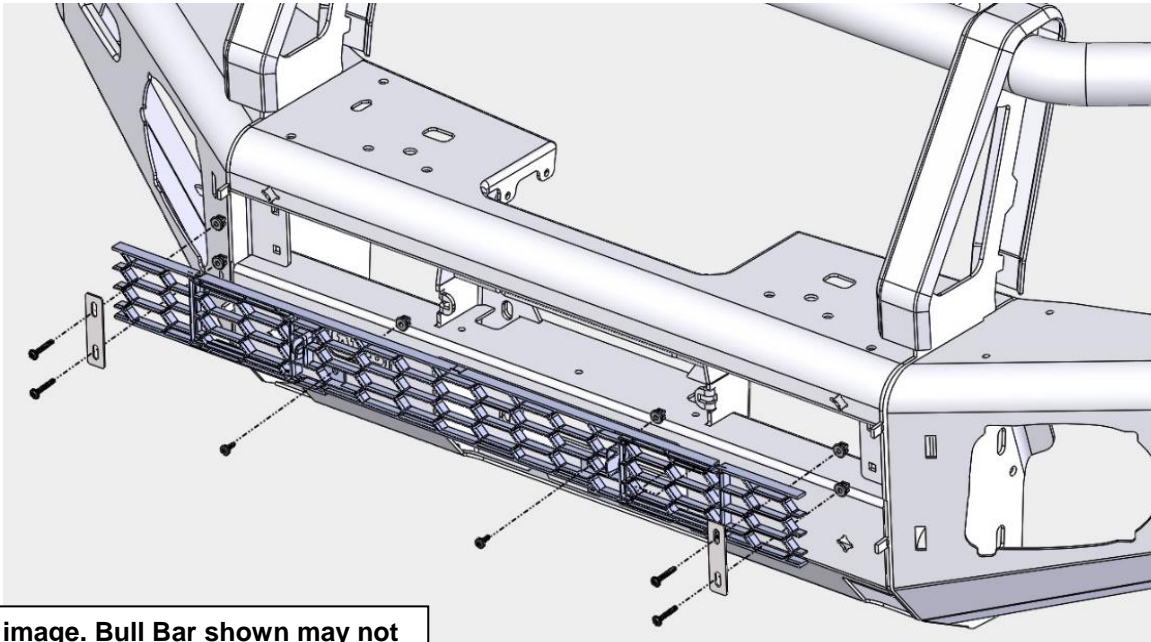

Generic image. Bull Bar shown may not be representative of actual product.

47. Fit the rubber intersection mouldings to the base of each upright cover strap.

Generic image. Bull Bar shown may not be representative of actual product.

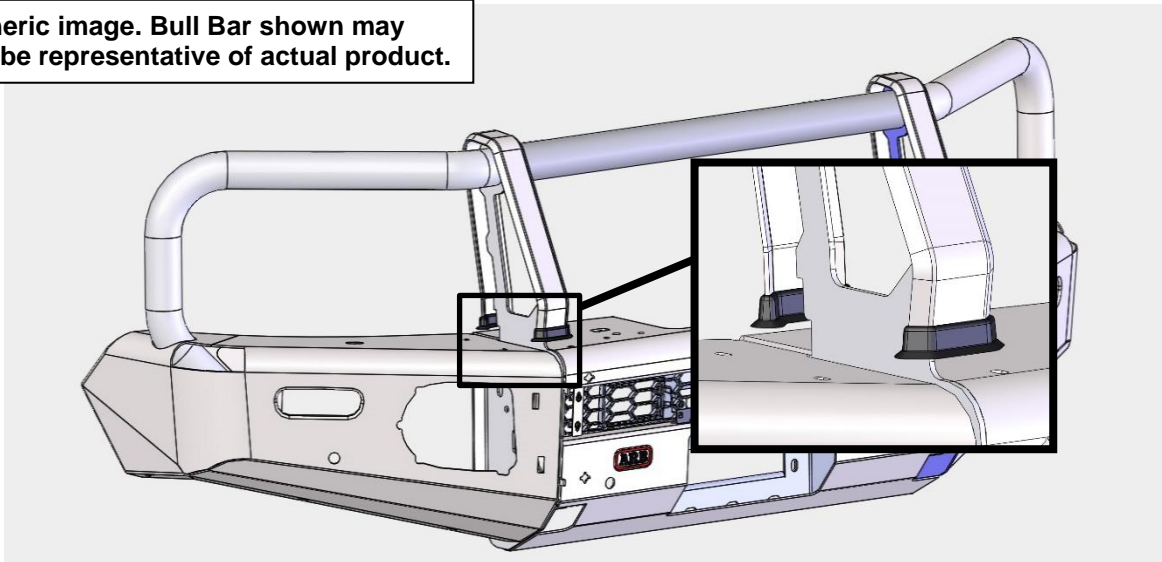

48. From the rear of the bar, slide the rear buffer sections under the rubber mouldings.

Fit 4 x screws and washers. Do not tighten screws. Leave enough play in buffers for adjustment later.

Note: Ensure that the skirts of the rubber intersection mouldings are not folded back on themselves and are sitting flat against the buffers.

Generic image. Bull Bar shown may not be representative of actual product.

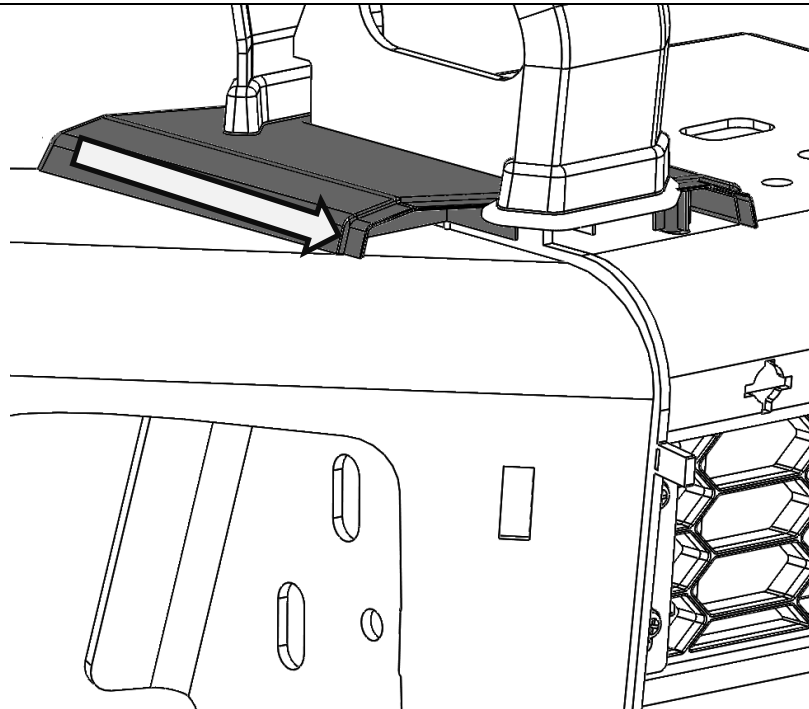

Fit washers under screw heads

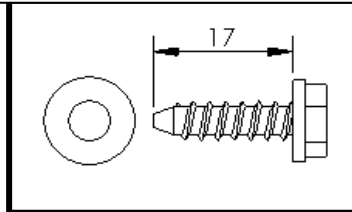

49. By aligning the front buffer with the tongue of the rear buffer, attach the front buffers to the front face of the bar. Ensure each buffer sits flat against the face of bar and is keyed into the top section of the rear buffer.

Secure wing side using retaining clips.

Secure inner side using the angled cup washers, flat washers and screws.

The widest point of the cup washers goes to the top of the bar.

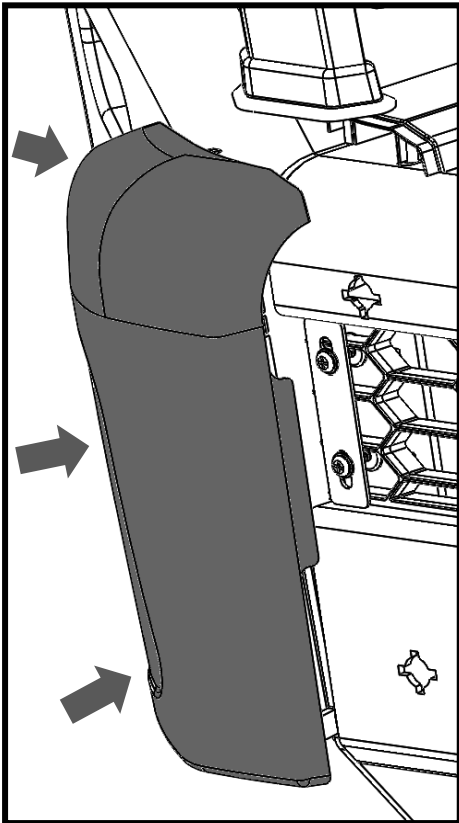

Generic image.
Bull Bar shown
may not be
representative of
actual product.

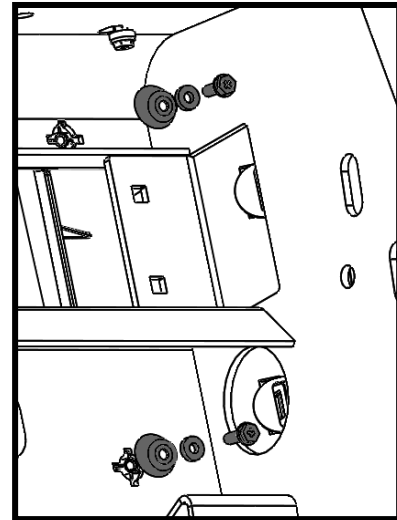

Fit washers under screw heads.

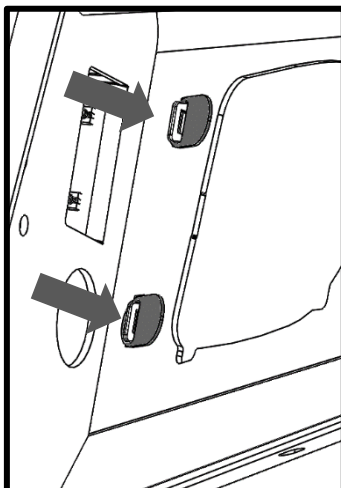
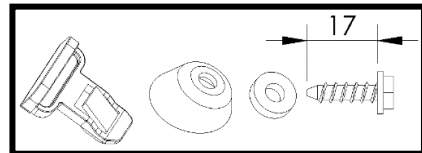

Fit 5848428 shims over
tabs.

Note: If clips are too
tight to engage, shims
may be removed to
reduce tension

Generic image.
Bull Bar shown
may not be
representative of
actual product.

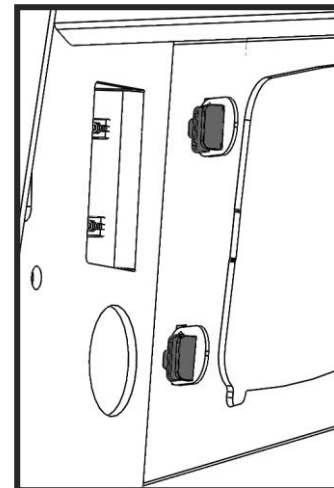

Slide retaining clips
through tabs to lock
buffer in place

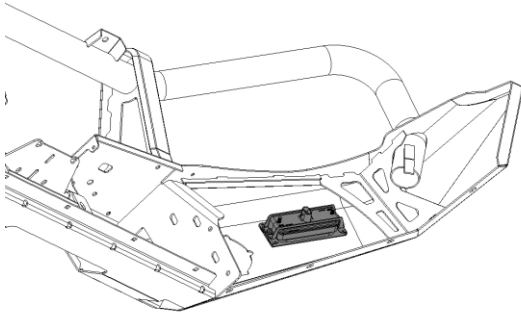

50. Fit the small plastic (square) grommets to the bar and attach the combination LED lamps to the bar using the screws provided with the lamp kit.

Caution: Cable tie all cables together and keep all cables clear of sharp edges and moving parts.

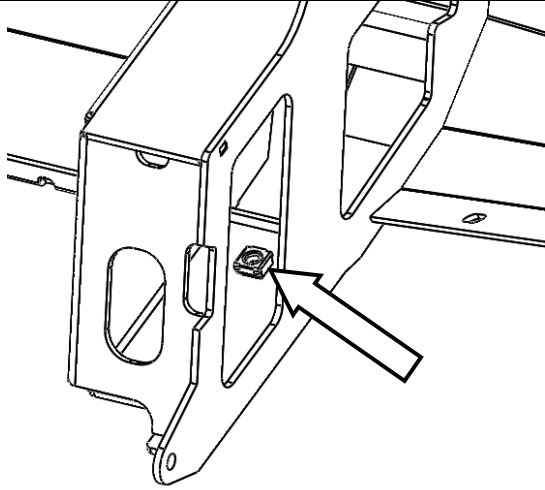
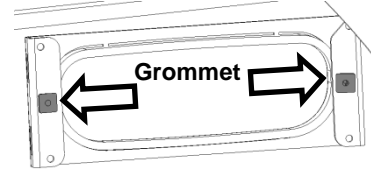

51. Fit both M8 cage nuts to the undersides of the mounting brackets on both sides of the bull bar.



52. Assemble and install combination light surrounds (p/n 3163082) as per instructions no. 3789190 supplied with surround kit.

Note: Optional fog lamps can be installed at this point as per fitting instruction supplied with fog lamp kit no. 3500590

Fog lamp loom 3500530 must also be installed on vehicles fitted with factory fog lamps due to higher current draw of ARB lamp.

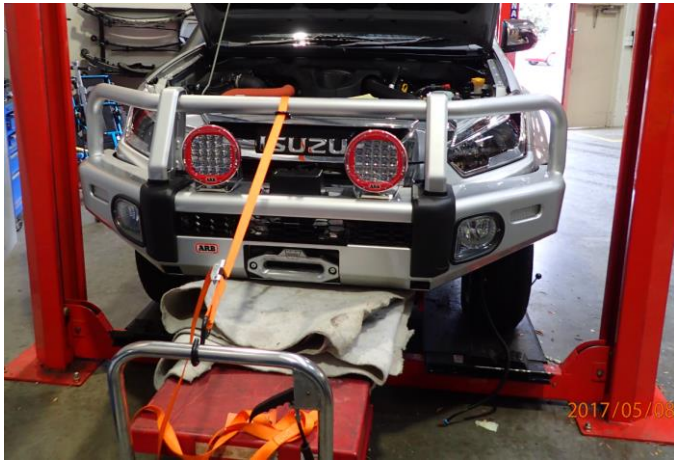

Warning: Drilling operations can result in flying metal debris, safety glasses should be worn.

53. Ensure all other aftermarket accessories such as driving lights/winch/UHF aerial have been fitted to the bull bar.

NOTE: Winch Roller Fairlead must be drilled to 25mm offset if not already done so.

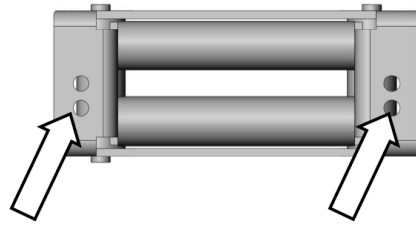

54. With the aid of a lift table or one or more assistants carefully and safely lift then position and loosely bolt the bull bar to the mounts using 4 x M12 bolts, large flat washers, spring washers and M12 flange nuts. Using a spirit level position the bar so that the top face is level with the side-steps.

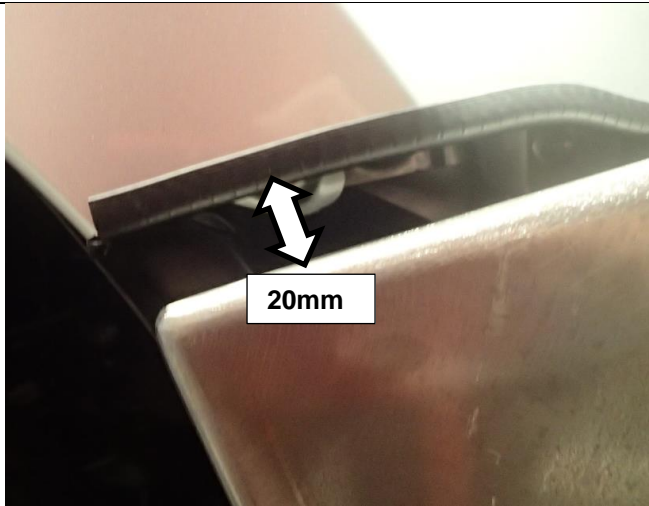

55. Align the bull bar wing with the bumper cut on each side of the vehicle; clearance should be between 18 and 22mm.

NOTE: DO NOT DO UP TIGHT

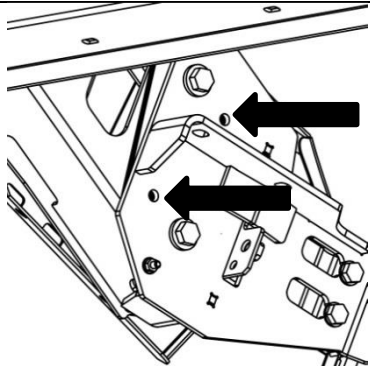

56. Once satisfied with the position of the bar on the vehicle drill the four Ø10mm pinning bolt holes with a 10.5mm drill bit from the inside of the bar (2 per mount).



Warning: Drilling operations can result in flying metal debris, safety glasses should be worn.



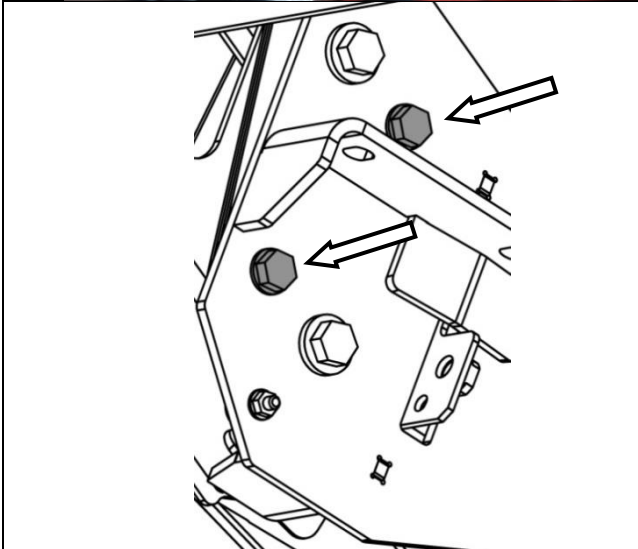

57. Measure the distance between the RHS vehicle and the RH bull-bar wing. Repeat on the LH side to confirm the bar is sitting centrally on the vehicle.
58. If not, remove the bar from its mounts and shift the required number of 2.5mm packers installed on the bull-bar mounts from one mount to the other. Next re-fit the bar on the mounts lining up the $\text{\O}10\text{mm}$ holes drilled in previous steps.



59. Once satisfied with the fitment of the bar to the vehicle, fit the M10 x 40 sems bolts to the RH & LH mounts (4 off - 2 per mount).

Torque to specification.

 M10 44 Nm

 M12 77 Nm



60. Connect electrical plugs for parking sensors, fog lights, driving lights and indicators.

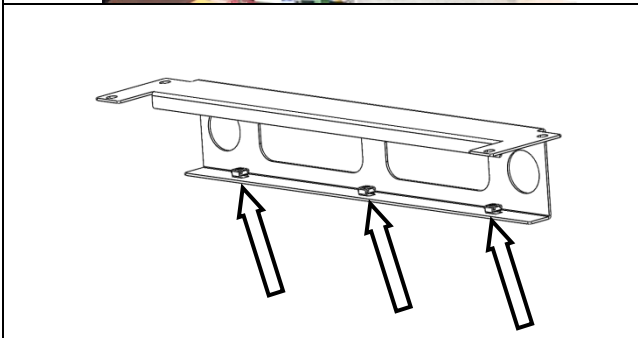

61. Fit three M8 cage nuts to the centre bull-bar brace.
Ensure the cage nuts are inserted with their legs orientated such that they can slide along the rectangular slots.

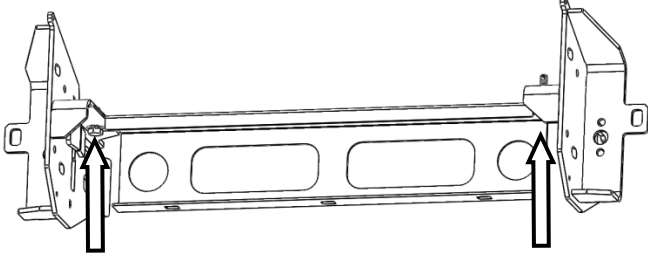

62. Loosely fit the centre bull-bar brace to the bull-bar mounts using four M10 x 35 sems bolts and four flange nuts.

After confirming that the vehicle stone guard bolt holes will fit and line up with the M8 cage nuts in the bull-bar brace tighten the four M10 sems bolts.

Torque to specification.



M10 - 44 Nm

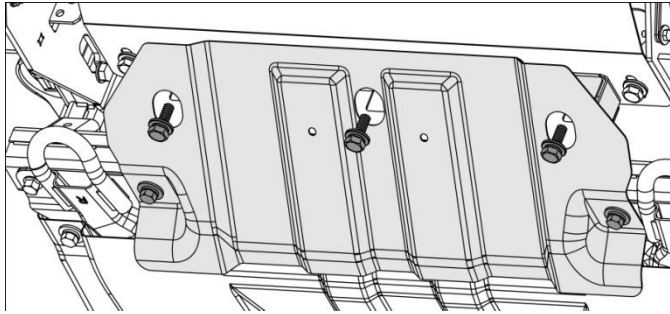

ORIGINAL VEHICLE SPLASH GUARD SHOWN

63. Fit the centre stone guard to the bull-bar along with the original vehicle splash guard (pressed metal). Use M8 black hex bolts, spring washers, flat washers for stone guard and original M10 hardware for OEM splash guard.



M8 - 22 Nm.



M10 - 44 Nm.



64. Place four M6 cage nuts in top surface of each wing panel. Loosely fit the RH and LH wing stone guards to the bull-bar. As shown on the adjacent photo, use a white marker to draw a line on the wheel liner at the lower rear edges of the stone guards.



65. Remove the two wing stone guards and mark a second line 5mm above the first line on the RH and LH wheel liners.

Cut off the lower portion of the wheel liners at the upper line with a utility knife or oscillating Multitool.



66. Fit panels up inside wings; secure using M6 x 20 black button head bolts and washer sets. Fix panel to side of upright using M8 bolt, washer sets and flange nut.



M6 - 9 Nm.



M8 - 22 Nm.

FINAL CHECKS:

- Check wiring connections to fitted lights.
- Check operation of all lights.
- Check operation of winch if fitted.

IMPORTANT: Check that all piping and wiring is clear of sharp edges and pinch points. Adjust any piping to clear the bull bar or mounts by a minimum of 15mm.

FITTED PRODUCT

