



FITTING INSTRUCTIONS

Part Number: **3440500**
Product **DELUXE WINCH BULL BAR**
Description:
Suited to **FORD RANGER PX 2011ON**
vehicle/s:
Winch Install **3500720 - SUMMIT BAR WINCH INSTALL KIT**
Kit:

WARNING

REGARDING VEHICLES EQUIPPED WITH SRS AIRBAG:

When installed in accordance with these instructions, the front protection bar does not affect operation of the SRS airbag.

ALSO, NOTE THE FOLLOWING:

- ◆ This product must be installed exactly as per these instructions using only the hardware supplied.
- ◆ In the event of damage to any bull bar component, contact your nearest authorised ARB stockist. Repairs or modifications to the impact absorption system must not be attempted.
- ◆ Do not use this product for any vehicle make or model, other than those specified by ARB.
- ◆ Do not remove labels from this bull bar.
- ◆ This product or its fixing must not be modified in any way.
- ◆ The installation of this product may require the use of specialized tools and/or techniques
- ◆ It is recommended that this product is only installed by trained personnel
- ◆ These instructions are correct as at the publication date. ARB Corporation Ltd. cannot be held responsible for the impact of any changes subsequently made by the vehicle manufacturer
- ◆ During installation, it is the duty of the installer to check correct operation/clearances of all components
- ◆ Work safely at all times
- ◆ Unless otherwise instructed, tighten fasteners to specified torque

ARB 4x4 ACCESSORIES

Corporate Head Office

42-44 Garden St
Kilsyth, Victoria
AUSTRALIA 3137

Tel: +61 (3) 9761 6622
Fax: +61 (3) 9761 6807

Australian enquiries
North & South American enquiries
Other international enquiries

sales@arb.com.au
sales@arbusa.com
exports@arb.com.au

www.arb.com.au

GENERAL CARE AND MAINTENANCE

By choosing an ARB Bar, you have bought a product that is one of the most sought after 4WD products in the world. Your bar is a properly engineered, reliable, quality accessory that represents excellent value. To keep your bar in original condition it is important to care and maintain it following these recommendations:

- Prior to exposure to the weather your bar should be treated to a Carnuba based polish on all exposed surfaces. It is recommended that this is performed on a six monthly basis or following exposure to salt, mud, sand or other contaminants.
- As part of any Pre Trip Preparation, or on an annual basis, it is recommended that a thorough visual inspection of the bar is carried out, making sure that all bolts and other components are torqued to the correct specification. Also check that all wiring sheaths, connectors, and fittings are free of damage. Replace any components as necessary. This service can be performed by your local authorized ARB Stockist

Important electrical system information

The 2011-On Ford Ranger uses an advanced wiring system allowing new chassis control systems to be used. Due to this, placing large amounts of additional load to the wiring harness may trigger faults in the ECU or cause permanent damage to the wiring harness.



To prevent overloading the turn and clearance lights must be activated through relays. Relay looms are provided within this kit to wire these lights. For further reference please see the attached wiring diagram at the end of these instructions.

FITTING REQUIREMENTS

REQUIRED TOOLS FOR FITMENT OF PRODUCT:

BASIC TOOL KIT	ELECTRIC DRILL & Ø2, Ø5.5, Ø7 & Ø10MM BITS
JIG SAW OR MULTI-TOOL WITH BLADE SUITABLE FOR PLASTIC	MATTE BLACK SPRAY PAINT
FILE OR SAND PAPER	MASKING TAPE
BASIC MEASURING TOOLS	ELECTRICAL TAPE (BLACK)
CONVOLUTED TUBE (7MM & 12MM)	HACK SAW OR EQUIV.
TORQUE WRENCH 9-100 NM CAPACITY	Large G-Clamp
LOCTITE 243	

HAVE AVAILABLE THESE SAFETY ITEMS WHEN FITTING PRODUCT:

Protective eyewear		Hearing protection	
--------------------	---	--------------------	---

NOTE: 'WARNING' notes in the fitting procedure relate to OHS situations, where to avoid a potentially hazardous situation it is suggested that protective safety gear be worn or a safe work procedure be employed. If these notes and warnings are not heeded, injury may result.

FASTENER TORQUE SETTINGS:

SIZE	Torque Nm	Torque lbft
Plastic screw	0.8Nm	0.7
M6	9Nm	7lbft
M8	22Nm	16lbft
M10	44Nm	32lbft
M12	77Nm	57lbft
M16	90Nm	66lbft

PARTS LISTING

APPLICATION.	PART NO.	DESCRIPTION	QTY
FIT MOUNT BRACKET TO CHASSIS	3759563	BRACKET CHAS MOUNT RANGER LRG RAD	1
	3759574R	BRACKET CHASSIS BRACE INNER RIGHT	1
	3759574L	BRACKET CHASSIS BRACE INNER LEFT	1
	3759575R	BRACKET CHASSIS BRACE OUTER RIGHT	1
	3759575L	BRACKET CHASSIS BRACE OUTER LEFT	1
	3759576R	BRACKET BULL BAR BRACE RIGHT	1
	3759576L	BRACKET BULL BAR BRACE LEFT	1
	4584375	SPACER Ø1 ¼" 15MM THICK	2
	5848427	PACKER CHASSIS 5MM THICK	4
	6151357	BOLT SEMS M10 X 30 ZP Gd 8.8	10
	4581011	WASHER FLAT, M12 x 27 x 4	10
	4581083	WASHER FLAT, M10 x 21 x 2 ZP	2
	4581050	WASHER SPRING 1/2 x 3/16 x 3/16 ZP	10
	4581048	WASHER SPRING M10 TZP480	2
	6151360	BOLT M12 x 1.75 x 35 Gd 8.8 ZP	10
	6151428	NUT FLANGE M12 X 1.75 ZP	10
	6151456	BOLT M10 x 1.5 x 45 Gd 8.8 ZP	2
	6151727	BOLT HXFL M16 x 2.0 x 35 FT PC8.8 TZP	2
	6151728	NUT FL SM M16 x 2.0 PC8 TZP	2
FIT BAR TO MOUNT BRACKET	4584376	SPACER Ø1 ¼ " 35MM THICK	2
	6151357	BOLT SEMS M10 X 30 ZP Gd 8.8	4
	6151306	NUT CAGED M12 1.8-3.2	6
	4581050	WASHER SPRING 1/2 x 3/16 x 3/16 ZP	6
	6151360	BOLT M12 x 1.75 x 35 Gd 8.8 ZP	4
	6151168	BOLT M12 x 1.75 x 80 CL8.8 ZP	2
	3194293	PLATE NUT MOUNT RANGER T6	2
	4581007	WASHER FLAT 1/2 x 1.1/2 x 4MM SILVER	6
	6151321	NUT FLANGE M10 x 1.5 ZP	12
MISC	3787985	CUTTING TEMPLATE BUMPER RANGER	1
	6151349	8 - 15 X 15 mm BUTTON HEAD SELF TAPPING GP	2
	180302	CABLE TIE 4.8 X 180 MM BLACK	9
FIT LICENSE PLATE BRACKET	6151213	BOLT M6 x 1.0 x 20 Gd8.8 BZ	3
	4581287	WASHER SPRING M6 x 2.5 x 1.6 BLK ZN	3
	4584295	WASHER FLAT M6 X 12 X 1.3 BLK ZN	3
	6151128	NUT FLANGE M6 x 1.0 ZP	3
	3759488	BRACKET LIC PLATE FIXED LARGE RAD	1
	6821189	GROMMET RND FC 1500 080 090	2
	6151384	SCREW 10G x 5/8 SELF TAPPING	2
FIT WINCH ACCESS PANEL	6151213	BOLT M6 x 1.0 x 20 Gd8.8 BZ	4
	4581287	WASHER SPRING M6 x 2.5 x 1.6 BLK ZN	4
	4584295	WASHER FLAT M6 X 12 X 1.3 BLK ZN	4
	6151128	NUT FLANGE M6 x 1.0 ZP	4
	6522985	PRESS FORM WINCH COVER PANEL	1

PARTS LISTING

APPLICATION.	PART NO.	DESCRIPTION	QTY
FIT UNDER PANELS	6522940R	PANEL UNDER WING RANGER 11ON LRG RAD	1
	6522940L	PANEL UNDER WING RANGER 11ON LRG RAD	1
	3758957	BRACKET WING PANEL RANGER T6	2
	6151132	NUT FLANGE M8 x 1.25 ZP	7
	4581082	WASHER FLAT, M6 x 19 x 1.6 BZ	10
	4581047	WASHER SPRING M8 x 3/32 x 3/33 BLK	14
	4581287	WASHER SPRING M6 x 2.5 x 1.6 BLK ZN	10
	6151234	BOLT M8 x 1.25 x 25 Gd 8.8 BP	14
	6151213	BOLT M6 x 1.0 x 20 Gd8.8 BZ	10
	6151300	NUT CAGED M6 2.6-3.5	10
	6151301	NUT CAGED M8 3.3-4.7	7
	6522838	PANEL SPLASH RANGER T6	1
	3758956	BRACKET OE STONE SHEILD RANGER T6	1
	6151357	BOLT SEMS M10 X 30 ZP Gd 8.8	2
	6151321	NUT FLANGE M10 x 1.5 ZP	2
	4581307	WASHER FLAT, M8 x 20 x 2 BLK ZN	14
	LIGHTS AND MOULDINGS	6821287	LAMP LED INDICATOR CLEARANCE
3163082		KIT SURROUND ARB FOGLIGHT	1
6821116		GROMMET NYLON SNAP IN TYPE	4
3500880		GRILLE SPLIT PAN KIT	1
5100200		BUFF KIT 2PCE FRONT SECTION	1
5100210		BUFF KIT 2PCE REAR UPRIGHT BAR	1

FITTING PROCEDURE



Note: Read the instructions thoroughly before starting.

1. Open the bonnet and remove the plastic cover above the grille.

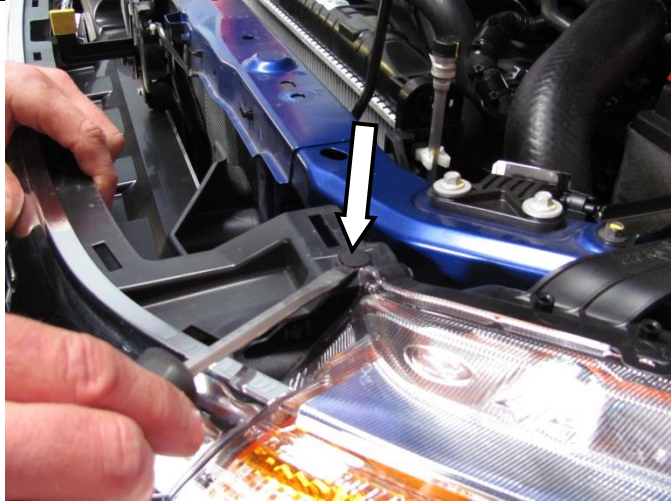

2. Remove the plastic clips from the top / rear corners of the grille. Place clips in a safe place.

Note: Take note where fasteners are removed from as some have to be replaced later in the fitment.

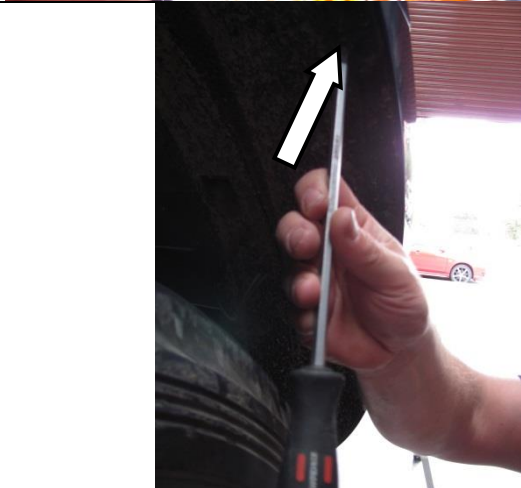

3. Remove all the bumper fasteners along the inside edge of the wheel arches.



4. Remove all the fasteners securing the bottom of the bumper to the vehicle.

FITTING PROCEDURE

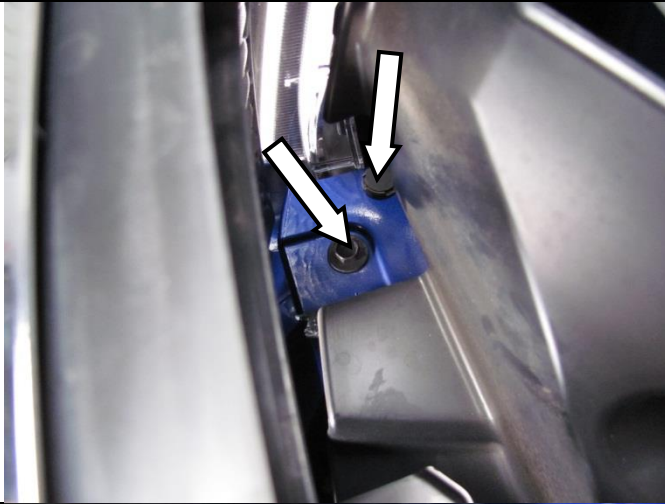

5. Undo and remove the screws and plastic clips behind the grille near the lower inner edge of the head lights.

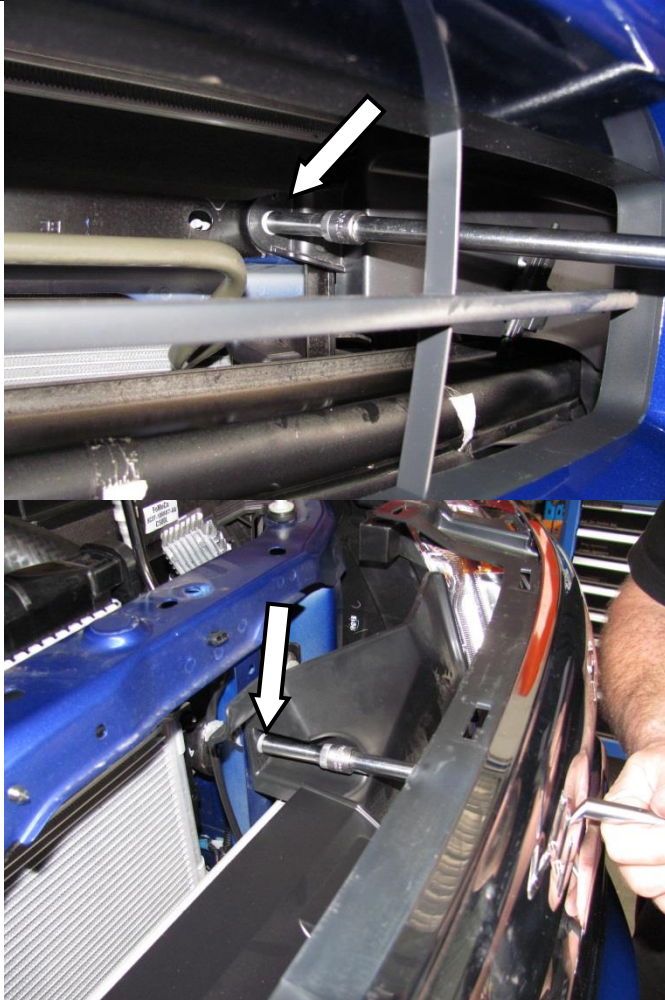

6. Using a socket extension, remove the screws holding the inner grille air deflectors to the vehicle. Place in a safe place.



7. Starting on the RH side of the vehicle, carefully pull the rear most corner away from the vehicle un-clipping the bumper. With the assistance of another person remove the bumper from the vehicle and place in a safe place where it will not be damaged. Disconnect the sensor attached to the bumper and allow it to hang loose. If fog lights are fitted they will need to be disconnected.

FITTING PROCEDURE

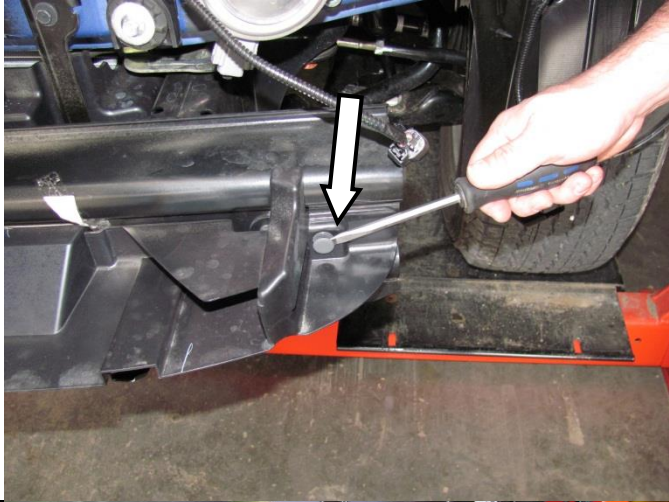

8. Remove the plastic panel attached to the front cross beam by removing the plastic clips. Discard the panel.



9. Use a screw driver to push the 2 x plastic clips inward from the front cross beam. Do not remove the clips as they will be used later.

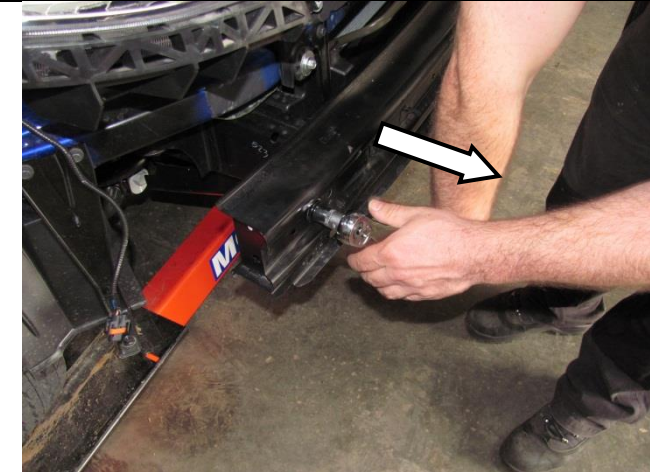

10. Remove the front cross beam and discard.



11. Remove the factory under panel and place in a safe place.

Do not completely remove the rear bolts. Leave loose.

FITTING PROCEDURE

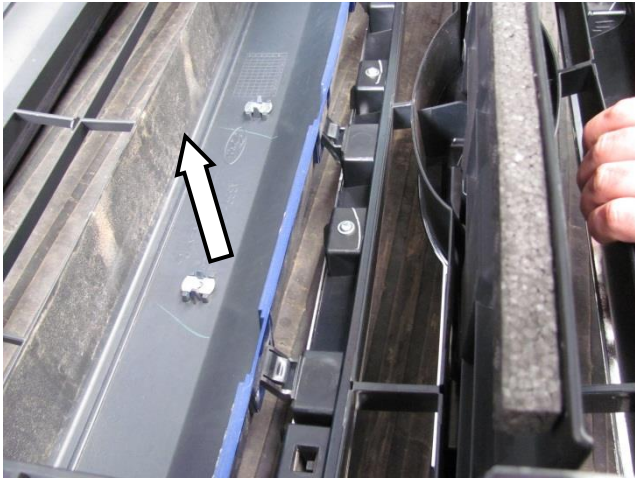

12. Carefully unclip the grille from the bumper and place in a safe place.



13. Remove the RH and LH bumper retention blocks from either side of the vehicle and place in a safe place.



14. Remove and discard the inner guard support brackets from both sides of the vehicle.



15. Starting with the RH bumper retention block removed in step 13, mark as shown using a white marker pen. *Note the position of the marking in relation to the lugs on the top edge of the block.*

16. Use a saw suitable for cutting plastic and cut along the marked line.



Marked Cut Line

Warning: Drilling operations can result in flying metal debris, safety glasses should be worn

FITTING PROCEDURE



17. Mark a line as shown parallel with the top edge in line with the tapered hole at the front of the block.
18. Mark a line from the end of the line marked in the previous step down to the bottom front corner of the block as shown.
19. Use a saw suitable for cutting plastic and cut along the marked line.
20. Use a file or sandpaper to de-bur all cut edges. The final part should like the one pictured.
21. Repeat steps 15-21 to mark and cut the LH block.
22. Set aside for later fitment.



Warning: Drilling operations can result in flying metal debris, safety glasses should be worn.

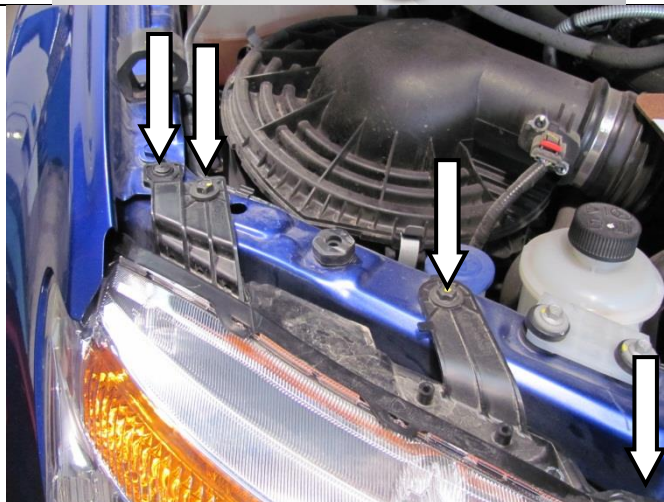

23. Starting on the RH side of the vehicle, remove the plastic clip, the 2 hex screws and the torx screw holding the headlight assembly in place and set aside.
24. Repeat on the LH side.



25. Carefully remove the head light assemblies from the vehicle, carefully unclipping the main head light globe plugs and completely removing both the turn light globes and left hand side clearance light globe.
26. Place the head light assemblies in a safe place where they will not be damaged.

FITTING PROCEDURE

27. Following fitting instructions 3789197 supplied in kit 6821287; attach the LED combination lamp looms (also supplied in same kit).

Notes:

-Use a test light or multi meter to pick the appropriate wire to attach the loom to.

-Use solder to connect the joints.

-Cover each joint with either insulation tape or heat shrink tube.



28. Carefully mask the area surrounding each side of the guard as shown (RH shown, LH same).

29. Thoroughly clean the area.

30. Using Matte Black spray paint, paint the masked area.

31. Allow to dry.

32. Re-fit the bumper retention blocks modified earlier.

Note: If you are fitting driving lights to the bar it is advisable that you install the wiring loom at this point.

FITTING PROCEDURE

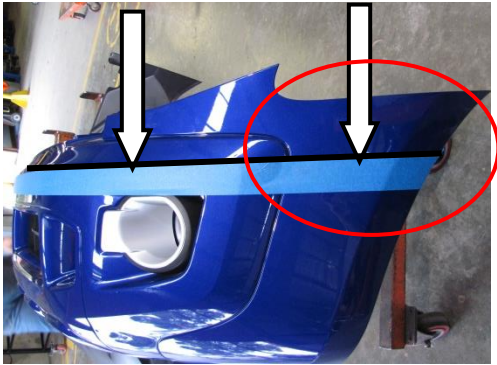

33. Remove the 2 x black plastic air deflectors attached to the bumper and set aside.
34. Place the bumper on a stand facing upwards.
35. Use masking tape to mark a straight line across the front of the bumper using the sharp corner at the front of the bar as a guide.



Note: The line should end up being 90mm below the edge of the bumper that mates with the vehicles guard.

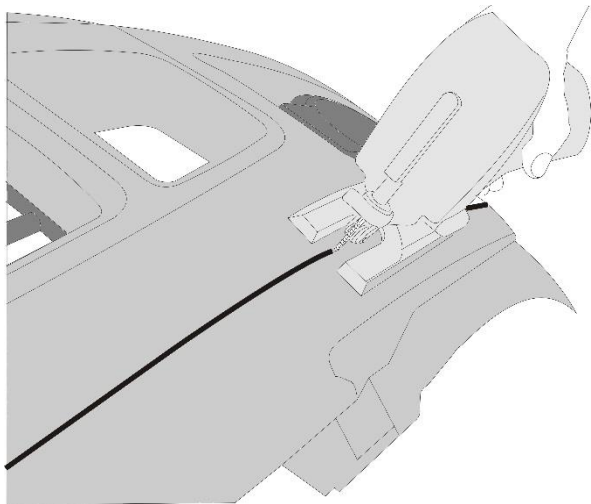

36. Using a jig saw or similar, carefully cut along the line made in the previous step.

Note: It is advised that you take steps to prevent damage to the bumper when cutting such as placing masking tape on the kept portion of the bumper.



Warning: Drilling operations can result in flying metal debris, safety glasses should be worn.

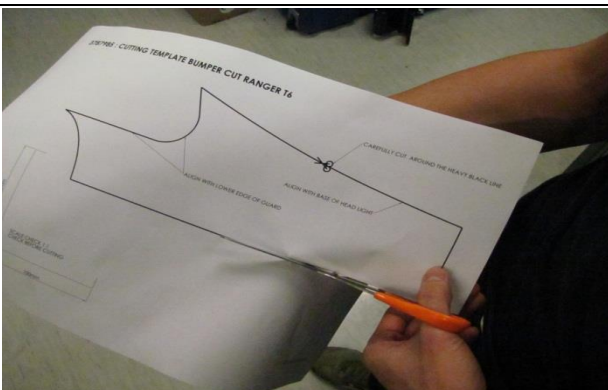

37. Using scissors carefully cut out the supplied paper template.

FITTING PROCEDURE



38. Attach the template to the bumper as shown using masking tape.
39. Place a piece of masking tape on the bumper at the rear of the template as shown (this will be used to mark on).



40. Using a marker pen, carefully trace a line along the rear most edge of the template continuing to the cut edge of the bumper.
41. Carefully remove the template and repeat on the opposite side of the vehicle by reversing the template.
42. Carefully cut along the marked lines removing the outer most sections of the bumper.

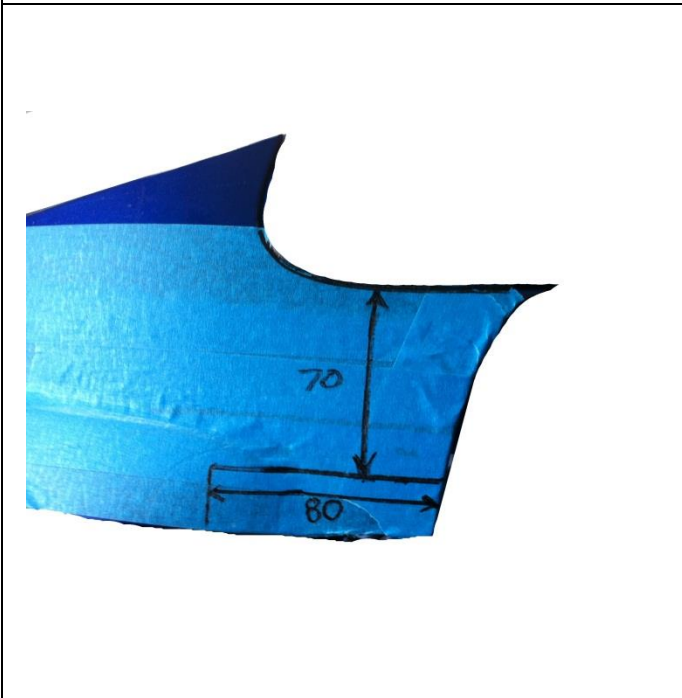

43. Mark 2 x lines on each side of the bumper 70mm down from the edge that mates with the vehicles guard and 80mm from the rear most edge as shown.
44. Carefully cut along the marked lines creating a rectangular notch. Discard the cut piece.
45. De-bur the cut edges with a file or sandpaper.

Warning: Be careful when cutting and de-burring that you don't damage the paint on the visual surfaces of the bumper.



Warning: Drilling operations can result in flying metal debris, safety glasses should be worn.

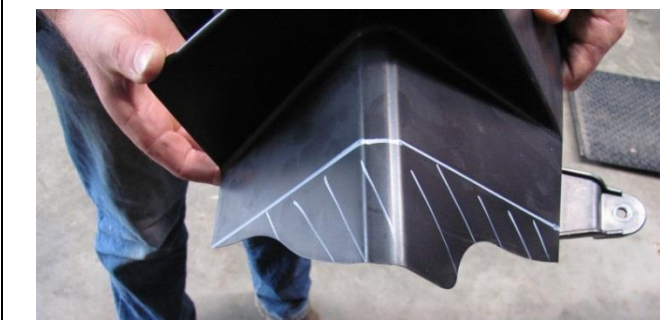

46. Mark the RH air deflector removed in step 6 as shown using the bottom edge of the lower mounting lug as a starting point across to the bottom corner of the opposite edge.
47. Carefully cut along the marked lines removing the lower off cut. Discard off cut.
48. De-bur the cut edges with a file or sandpaper.

FITTING PROCEDURE

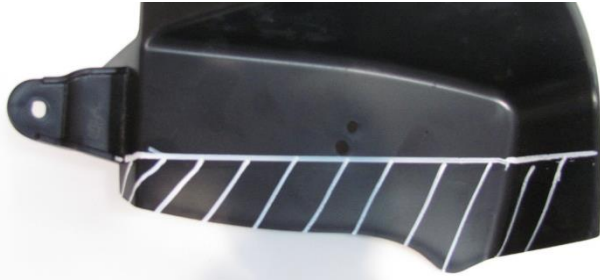

49. Mark the LH air deflector removed in step 6 as shown using the bottom edge of the lower mounting lug as a starting point, marking a line perpendicular to the vertical edge below the lug.
50. Carefully cut along the marked line removing the lower off cut. Discard off cut.
51. De-bur the cut edges with a file or sandpaper.

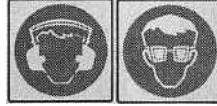

Warning: Drilling operations can result in flying metal debris, safety glasses should be worn.

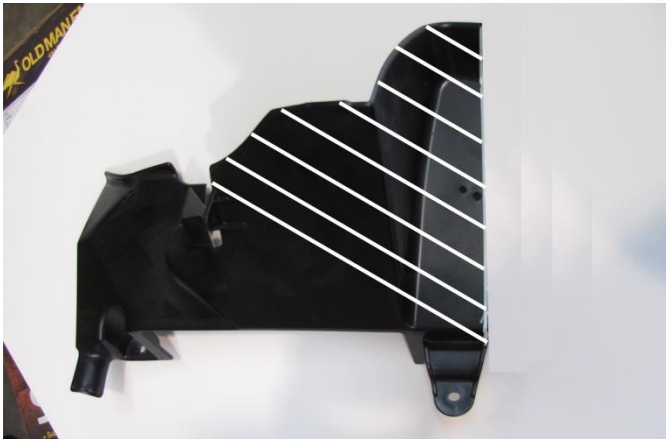

52. On both the RH and LH air deflectors, mark a line from the bottom corner of the lower mounting lug up to the forward / bottom edge of the bumper mounting lug as shown.
53. Carefully cut along the marked line removing the lower off cut. Discard off cut.
54. De-bur the cut edges with a file or sandpaper.
55. Refit the air deflectors to the vehicle using the 2 x factory screws in each side.
56. Refit the bumper to the vehicle by reversing the removal steps.



Warning: Drilling operations can result in flying metal debris, safety glasses should be worn.

FITTING PROCEDURE

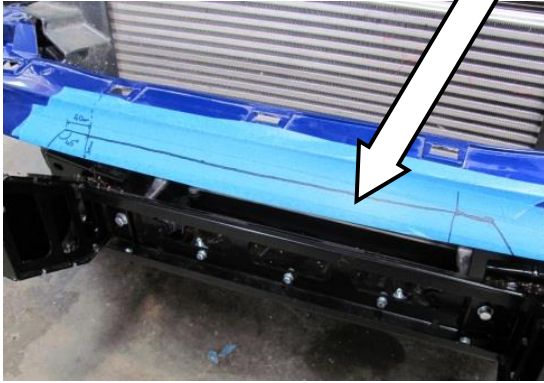
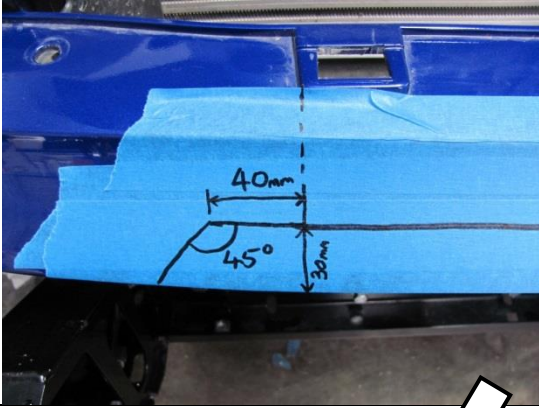

57. Tape the front centre face of the bumper as shown.
58. Using the outside edges of the 2 x grille clip receivers on either side of centre as guides, mark vertical lines directly down the front of the bumper.
59. Mark a parallel line 30mm from the bottom edge of the bumper starting and finishing 40mm outboard of the vertical line marked above.
60. On both sides of the vehicle mark a line 45 degrees down to the bottom edge of the bumper.
61. Carefully cut along the marked lines. Discard the cut piece.
62. De-bur the cut edges with a file or sandpaper.



Warning: Drilling operations can result in flying metal debris, safety glasses should be worn.

FITTING PROCEDURE



63. Drill a Ø2mm hole through each end corner of the bumper into the guard sheet metal.
64. Attach the bumper to the guards using the Phillips head self-tapping screws.



Warning: Drilling operations can result in flying metal debris, safety glasses should be worn.

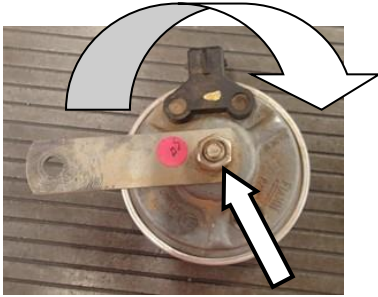
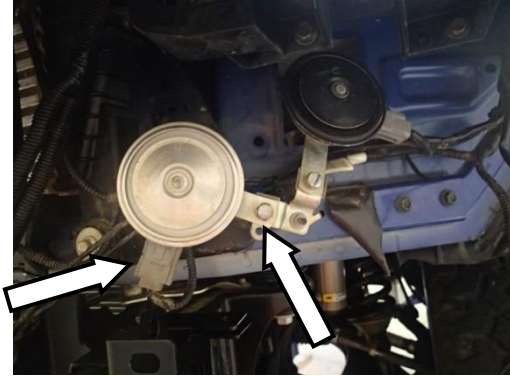

65. The horn & harness will require to be rotated for clearance to brackets. Unplug the harness and remove the horn by removing the mounting bolt.
66. Turn the horn over and loosen the retaining nut. Rotate the arm 180°, and tighten the retaining nut.
67. Re fit the horn in its original position and re-route the harness to the top. Use cable ties if necessary to reposition the harness.

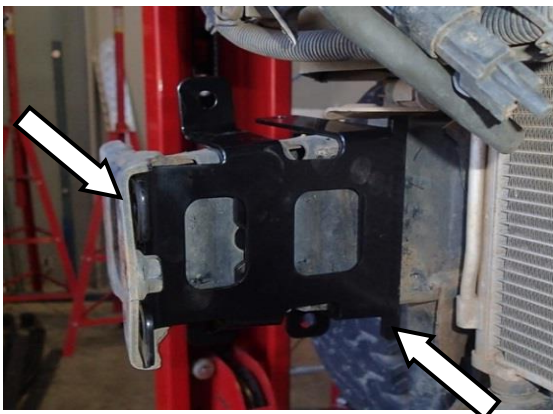

68. Fit the inner brace with the packer to the chassis rail end. Ensure that the front edge is pushed forward to the chassis flange. The brace may need to be tapped to ensure a flush fitment to the chassis is achieved.

FITTING PROCEDURE

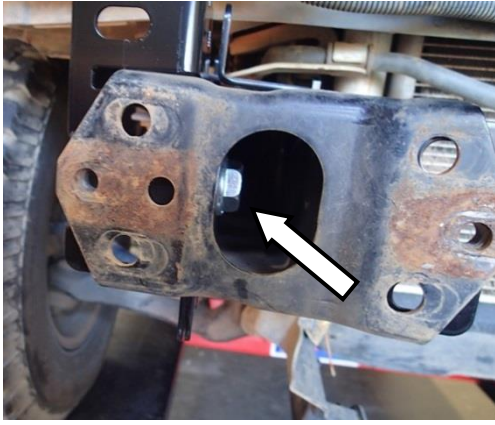

69. Fit the M16 x 35 flange bolt through the front access cut out of the front flange of the chassis.

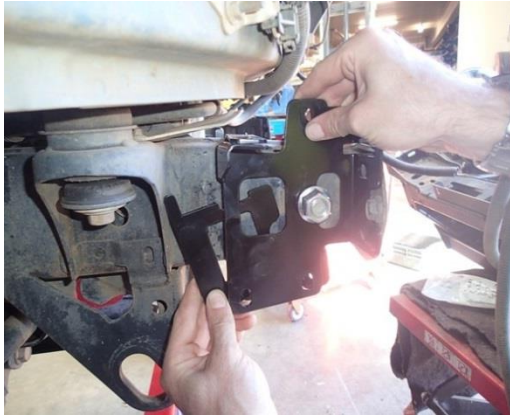

70. Loosely position the outer bracket brace with the packer to the chassis rail. Apply LOCTITE 243 then fit the M16 flange nut to hold it in place. Ensure that the front edge is pushed forward to the chassis flange.



71. Fit 4 x M12 x 35 bolts, 4 x M12 flat washers, 4 x M12 Flange nuts.

 M12 - 77 Nm.

NOTE: Do not fit the M12 spring washers these will be fitted later on.



72. Using a spanner to hold the M16 flange bolt, torque the M16 flange nut.

 M16 - 90 Nm.

NOTE: Take care to torque as per requirement. DO NOT torque outside the specs provided.

FITTING PROCEDURE

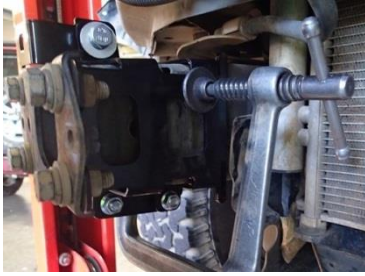

73. Using a large G-clamp, clamp the top rear corner of the outer and inner brace together. This will make the alignment of the top flange easier for fitment of the brace.
74. Fit the M10 x 1.5 x 45 bolt, M10 spring washer and M10 flat washer.

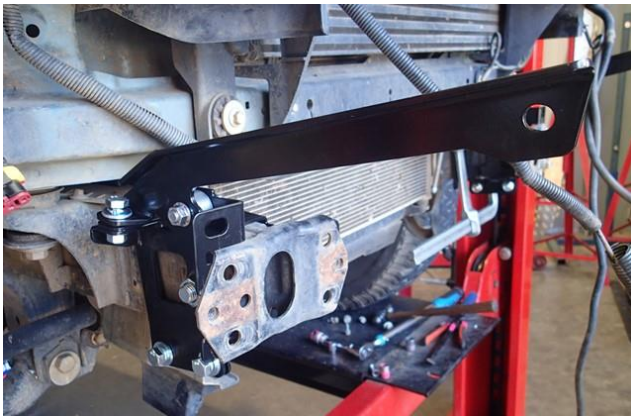
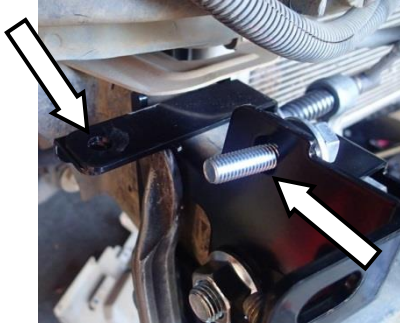

75. Fit the 2 x M10 x 30 SEMS bolts and M10 flange nuts to the bottom of the brackets to clamp them together.
76. Fit the M10 x 30 SEMS bolt and M10 flange nut to the brace and outer bracket.
77. Fit the 15mm wide spacer between the brace and the outer bracket and then fit the M10 flange nut
78. Remove the 4 x M12 x 35 bolts, 4 x M12 flat washers and 4 x M12 flange nuts fitted in step 71 and set aside for later.
79. **NOTE:** Keep all M10 fasteners loose and only finger tight at this point.

Repeat steps 68-79 for the LH side.

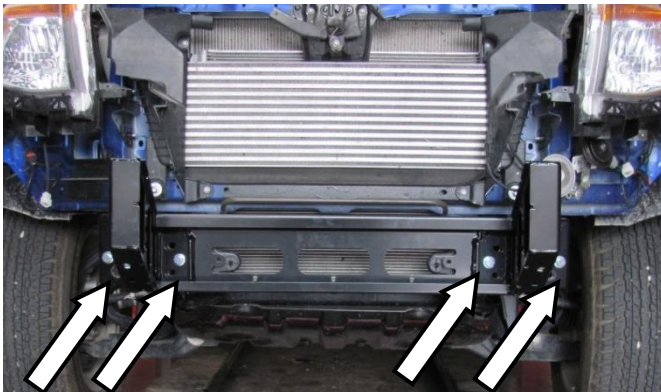

80. Attach the mount bracket to the chassis end plates using 4 x M10 x 30 SEMS bolts into the captive nuts.

Leave loose at this stage.

FITTING PROCEDURE

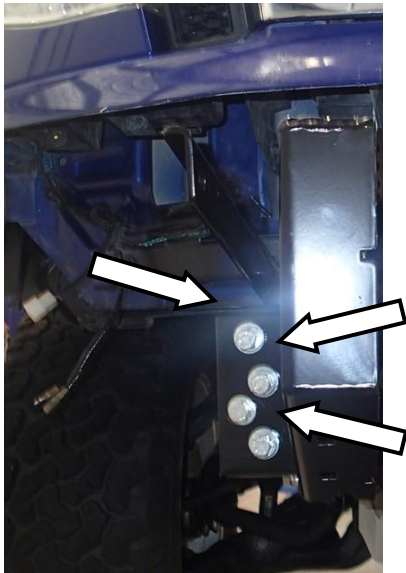

81. Attach the mount bracket to the chassis using 3 x M12 x35 bolts, 3 x M12 spring washers, 3 x M12 flat washers and 3 x M12 Flange nuts.
82. Repeat on the LH side.

 M12 - 77 Nm.

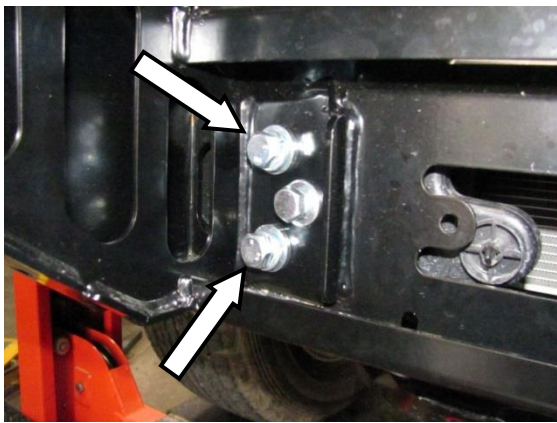

83. Place 2 x M12 x 35 bolts, 2 x M12 spring washers, 2 x M12 flat washers and 2 x M12 Flange nuts into the 2 holes on the inboard side of each chassis face plate.
Leave loose at this stage.
84. Repeat on the LH side.

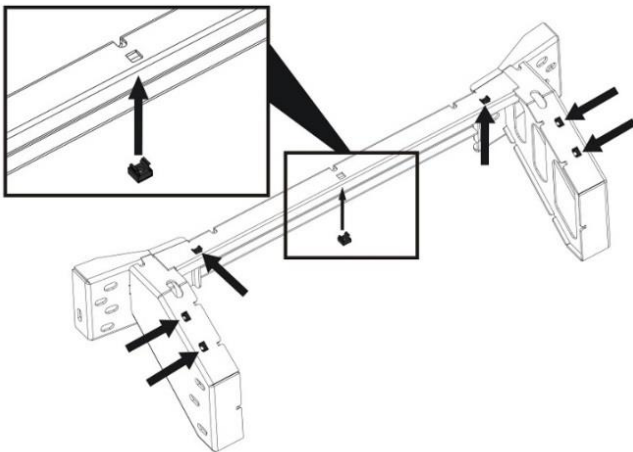

85. Fit 7 x M8 cage nuts into the mount bracket from the inside.
Note: A flat blade screw driver can be used to aid placement of the cage nuts.

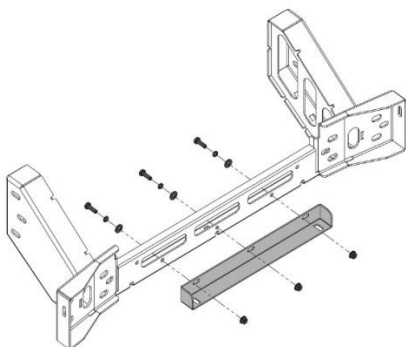

86. Attach the OE stone shield bracket to the chassis mount using 3 x M8 x 25 black bolts, 3 x M8 black flat washers, 3 x M8 black spring washers and 3 x M8 flange nuts.
Leave loose at this stage.

FITTING PROCEDURE

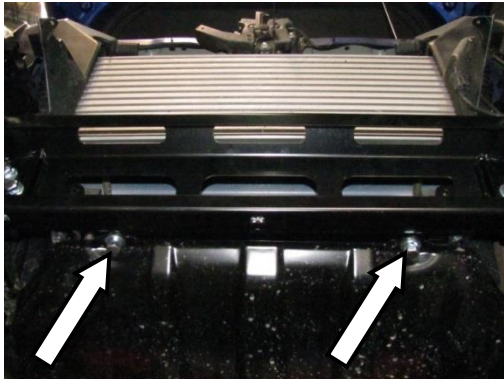

87. Re-fit the OE stone shield to the bracket fitted in step 86 using 2 x M10 x 30 SEMS bolts and 2 x M10 flange nuts.

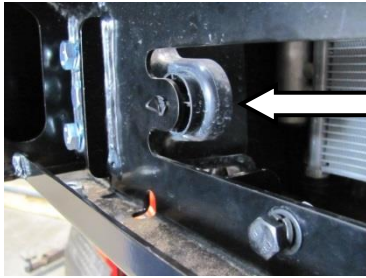
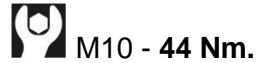

88. Using the original plastic clips re-fit the factory air deflector to the 2 x holes in the mount bracket.

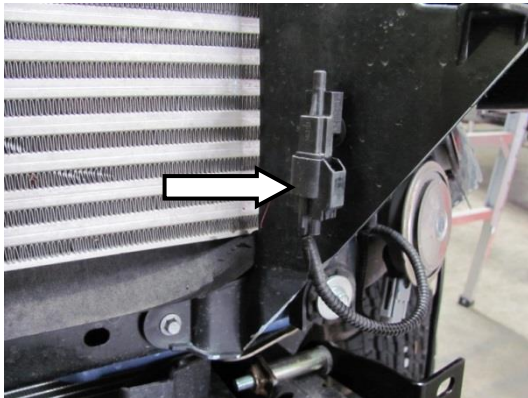

89. Using the pegs on the sensor removed in step 7 as a guide, Drill 2 x Ø5.5mm holes in the LH air deflector so that the sensor can be fitted approximately 40mm forward of the rear edge of the air deflector as shown.
90. Push the pegs into the drilled holes, attaching the sensor.



Warning: Drilling operations can result in flying metal debris, safety glasses should be worn.



91. Fit 3 x M12 cage nuts to each of the cage nut plates as shown.

FITTING PROCEDURE

Note: If fitting a winch proceed from here using fitting instructions 3789337 supplied with 3500720 winch install kit. Once the winch is fitted please continue to step 95. If no winch is being fitted continue from here.

92. Slide the winch cover panel from the bottom up until it is level with the top face of the bar.
93. Fit the winch cover panel to the bar using 4 x M6 x 20 hex bolts, spring washers, flat washers and flange nuts.

Warning: Be careful not to scratch the finish of the winch cover panel.

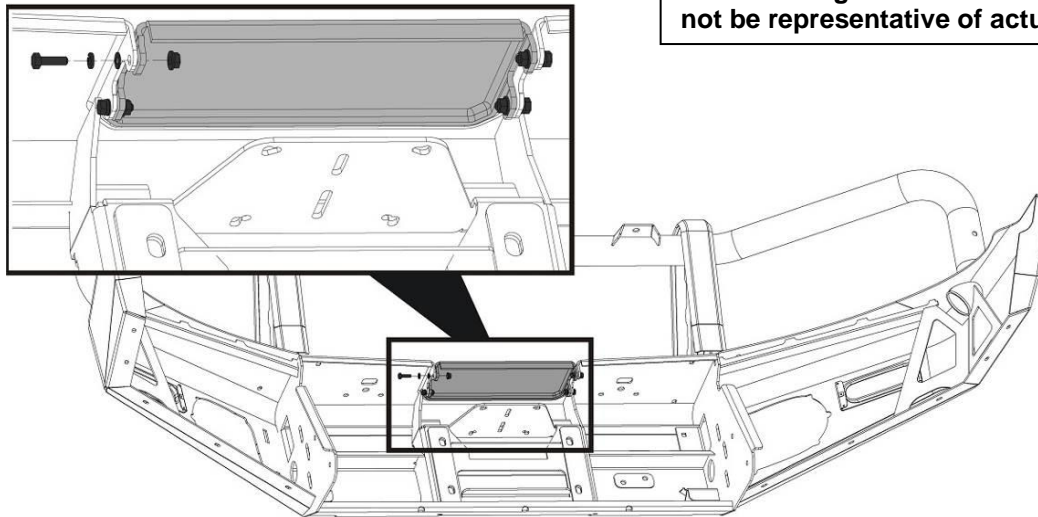

94. Fit the number plate bracket to the top face of the lower-centre pan on the bar using 3 x M6 x 20 hex bolts, spring washers, flat washers and flange nuts.

Note: If you are fitting a winch, fit the folding number plate bracket supplied in winch install kit "3500720 WINCH INSTALL KIT" – See fitting instructions 3789337

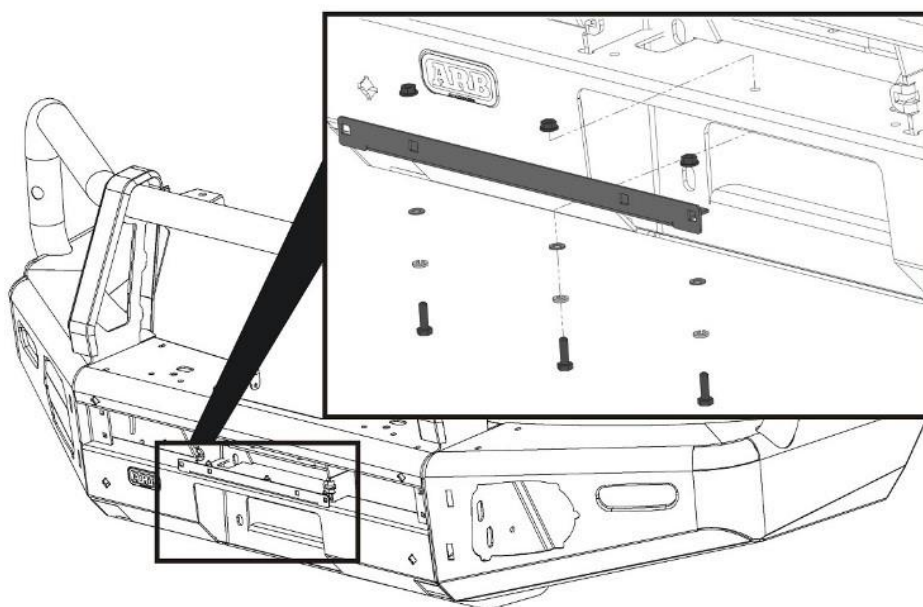

Note: The following steps show the fitment of the plastic moulded parts. The mouldings are supplied in kits along with all fasteners required for fitment. It is important that the fasteners supplied with each kit are only used for the mouldings from the same kit.

The kits included in this bar kit are as follows:

95. Layout the contents of each of the following kits ensuring the contents are kept separate from each other.

Kit No.	Description
5100200	BUFF KIT 2PCE FRONT SECTION
5100210	BUFF KIT 2PCE REAR UPRIGHT BAR
3500880	SPLIT PAN MESH KIT
3163082	FOG SURROUND KIT

96. Mark the grille panel to be cut at the 810mm marks at each end on the back face.

Note: When marked, double check the measurement with a measuring tool.

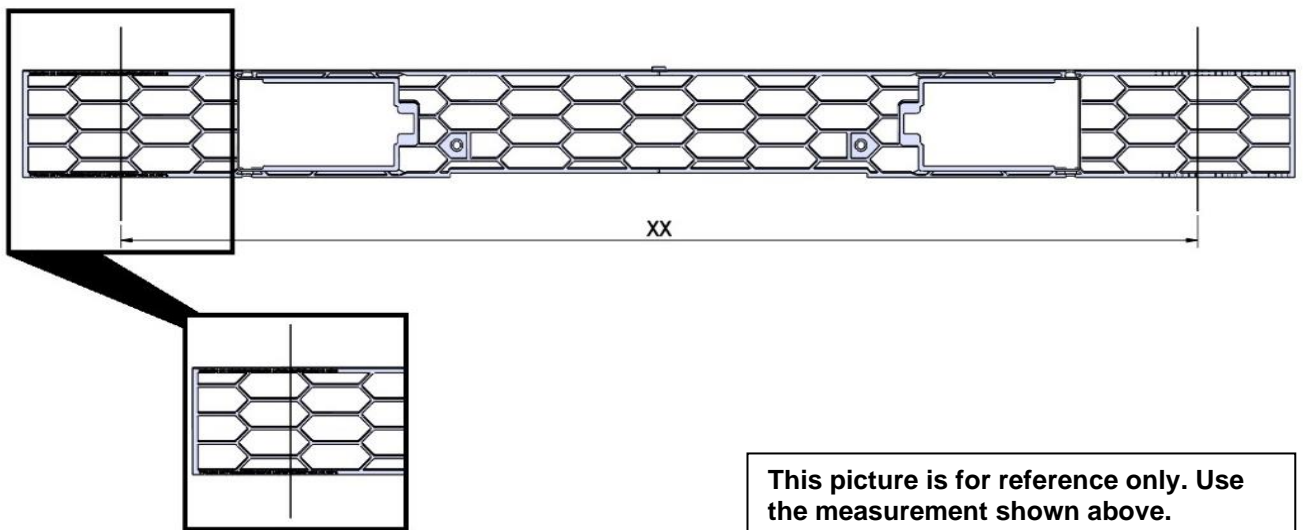

97. Use a hacksaw or similar cutting tool to carefully cut the grille panel at the positions marked in the step above.

98. Discard the off cuts and clean up the cut edges using a file or sandpaper.

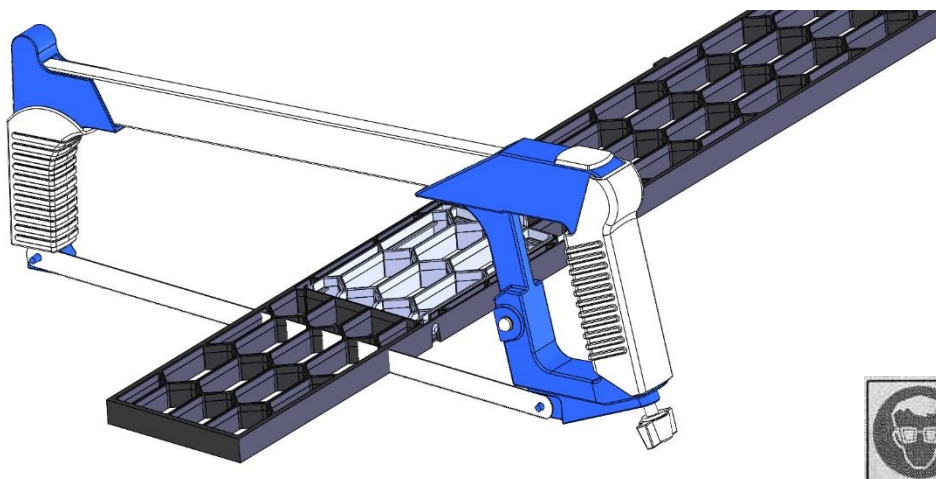

99. Insert the 6 x plastic grommets into the 6 square holes in the front face of the bar.
100. Insert the grille into the bar so that the hatches open outward (facing the front of the bar).
101. Attach the grille to the centre of the bar using the short screws into the grommets fitted above.
102. Attach the ends of the grille to the bar using the longer screws, through the clamp plates into the remaining grommets.

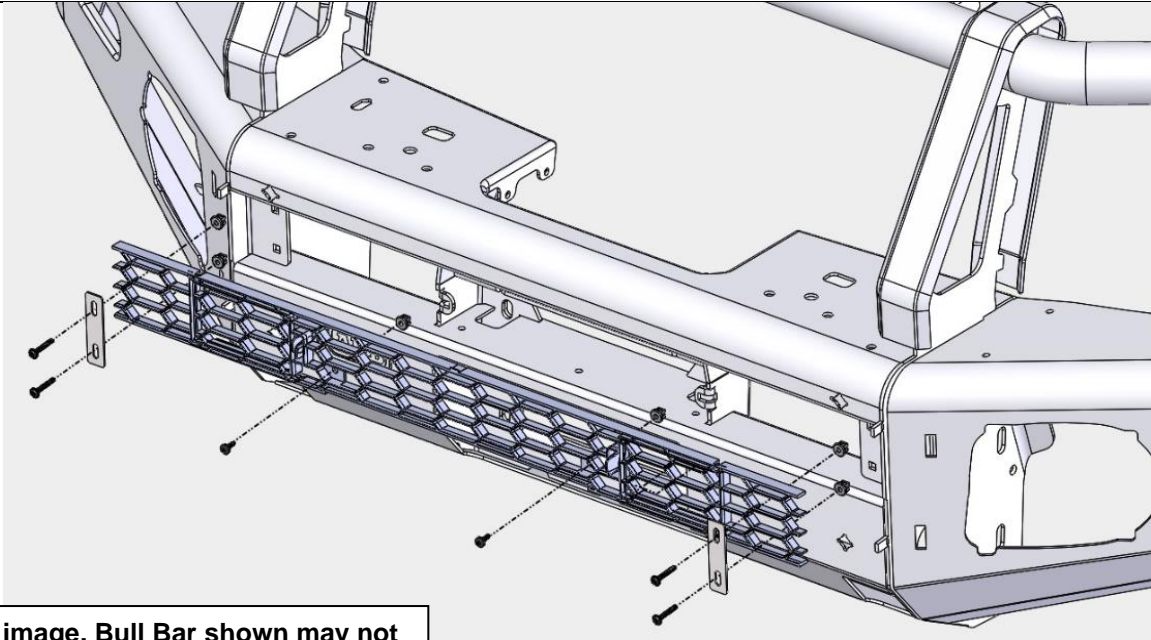

Generic image. Bull Bar shown may not be representative of actual product.

103. Fit the rubber intersection mouldings to the base of each upright cover strap.

Generic image. Bull Bar shown may not be representative of actual product.

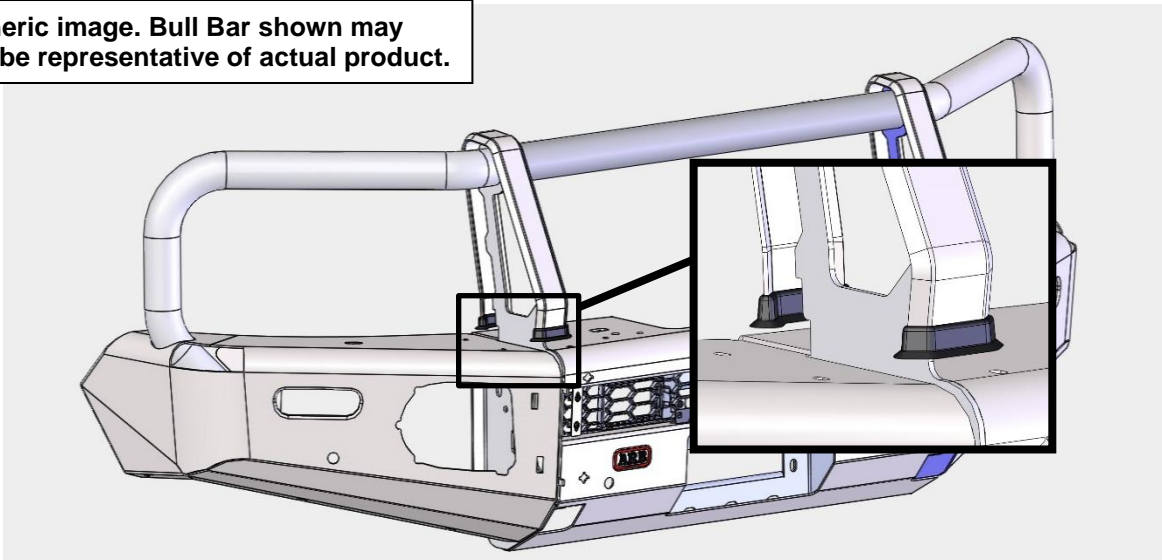

104. From the rear of the bar, slide the rear buffer sections under the rubber mouldings.

Fit 4 x screws and washers. Do not tighten screws. Leave enough play in buffers for adjustment later.

Note: Ensure that the skirts of the rubber intersection mouldings are not folded back on themselves and are sitting flat against the buffers.

Generic image. Bull Bar shown may not be representative of actual product.

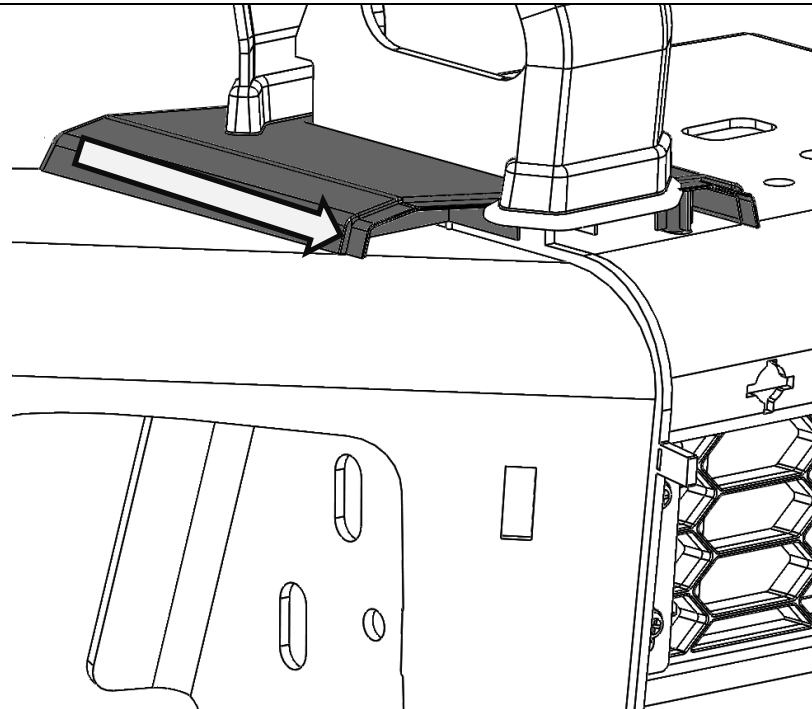

Fit washers under screw heads

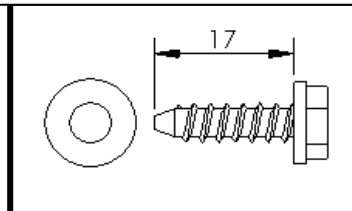

105. By aligning the front buffer with the tongue of the rear buffer, attach the front buffers to the front face of the bar. Ensure each buffer sits flat against the face of bar and is keyed into the top section of the rear buffer.

Secure wing side using retaining clips.

Secure inner side using the angled cup washers, flat washers and screws.

The widest point of the cup washers goes to the top of the bar.

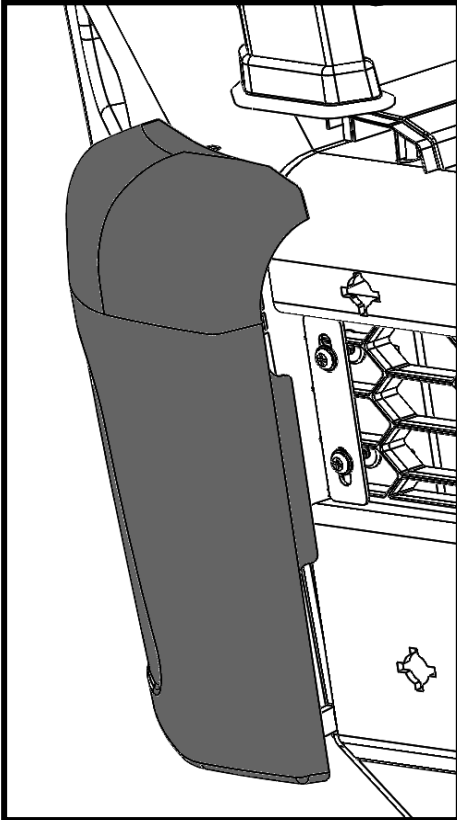

Generic image.
Bull Bar shown
may not be
representative of
actual product.

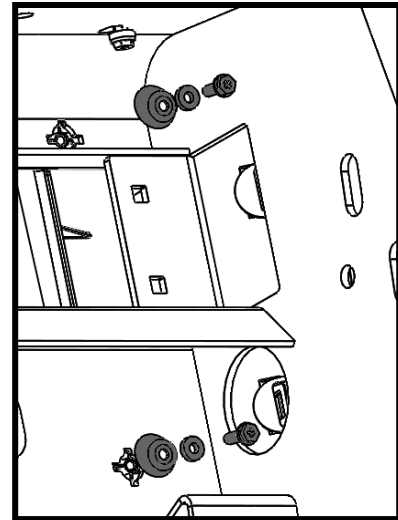

Fit washers under screw heads.

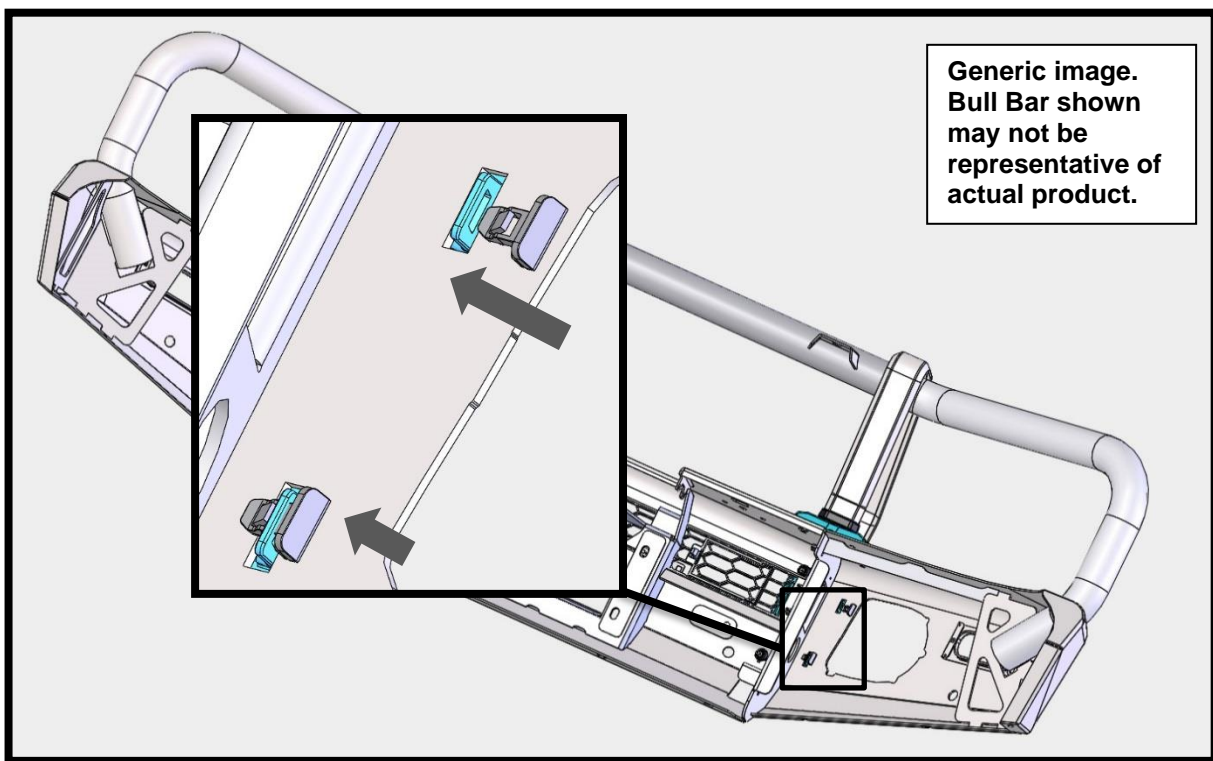
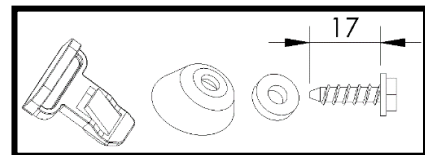

Generic image.
Bull Bar shown
may not be
representative of
actual product.

FITTING PROCEDURE

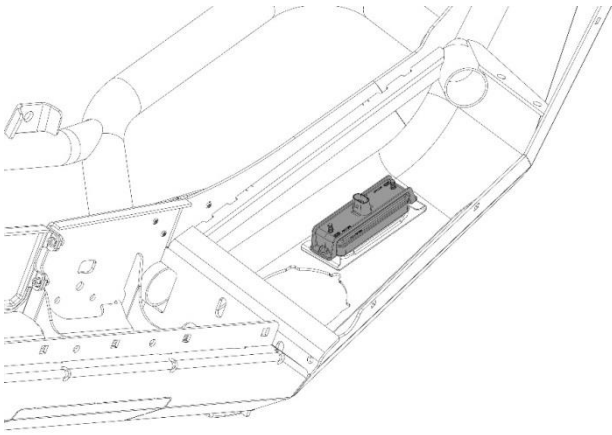

106. Fit the small plastic grommets to the bar and attach the combination LED lamps to the bar using the screws provided with the lamp kit.
107. Wire the combination lamp (kit: 6821287) to the vehicle's indicator and clearance lamp wiring.

Caution: Cable tie all cables together and keep all cables clear of sharp edges and moving parts.

Wiring:
Green wire is Turn signal + (pos)
Red is running lamp + (pos)
Black is - (neg)



108. With the assistance of another person, place the bar on the mount brackets.

Warning: Due to the weight of the bar and winch if fitted, it is advised that you use some form of mechanical assistance when lifting the bar onto the vehicle such as an elevating trolley.

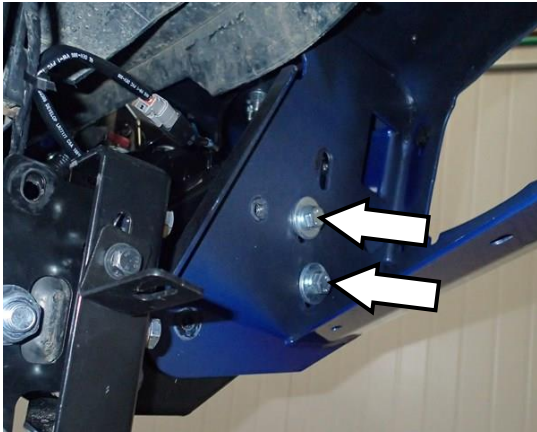

109. Attach the bar to the mount bracket using 2 x M12 x 35 bolts, 2 x M12 spring washers and 2 large diameter M12 flat washers, into the nut plates which are placed inside the box upright sections of the mount bracket. **Leave loose at this stage.**

110. Repeat for LH side

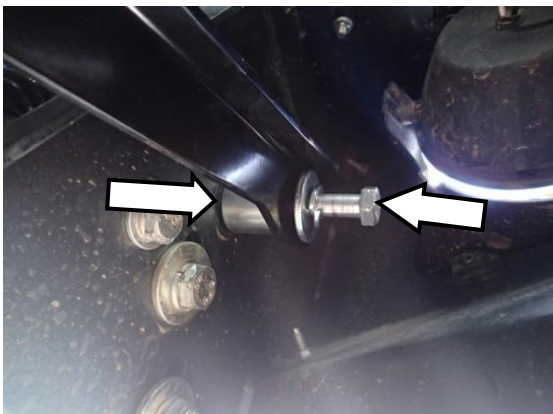

111. Fit the 35mm wide spacer and the M12 x 1.75 x 80 bolt, M12 washer and M12 spring washer.

Leave loose at this stage.

112. Repeat for LH side

FITTING PROCEDURE



- 113. Position the bar so that it is level and there is a gap between the top face of the wings and the bottom edge of the guards of 18-22mm and the wing tips are aligned with the edge of the wheel arch.
- 114. Centralise the bar and tighten all mounting bracket related fasteners to the specified torque.
- 115. Tighten the bar to mount fasteners to the specified torques for M10 and M12 sizes.

M10 - 44 Nm.
 M12 - 77 Nm.

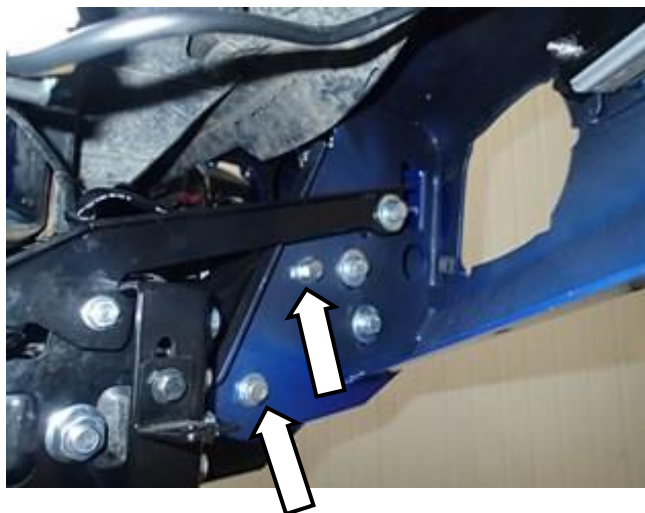

- 116. Double check the position of the bar.
- 117. When happy with the position of the bar drill 4 x Ø10mm pinning holes using the pre-cut holes in the bar uprights as guides.
- 118. Use paint or rust protection on the drilled holes.

Warning: Drilling operations can result in flying metal debris, safety glasses should be worn.

- 119. Pin the holes using 2 x M10 x 30 SEMS bolts and 2 x M10 flange nuts.
- 120. Repeat for LH side.

M10 - 44 Nm.



Warning: Drilling operations can result in flying metal debris, safety glasses should be worn.



- 121. Assemble and install combination light surrounds (p/n 3163082) as per instructions no. 3789190 supplied with surround kit. Note: Optional fog lamps can be installed at this point as per fitting instruction supplied with fog lamp kit no. 6821201.

CAUTION: Cable-tie all cables together and keep all cables clear of sharp edges and all moving parts.

- 122. Check the operation of all lights wired during bar fitment

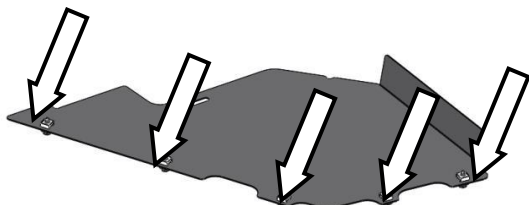

- 123. Fit 5 x M6 cage nuts to each of the under wing panels as shown.

FITTING PROCEDURE

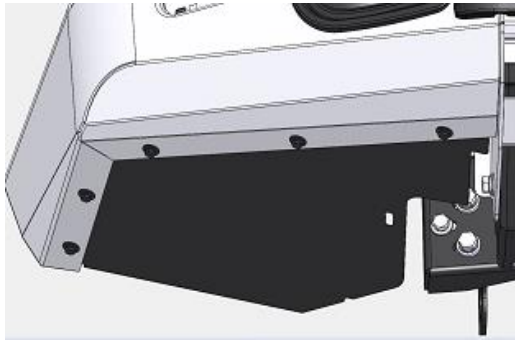

124. Fit the RH under wing panel to the RH wing as shown and attach using 5 x M6 x 20 hex bolts, 5 x M6 spring washers and 5 x M6 flat washers.

125. Repeat on the LH side.

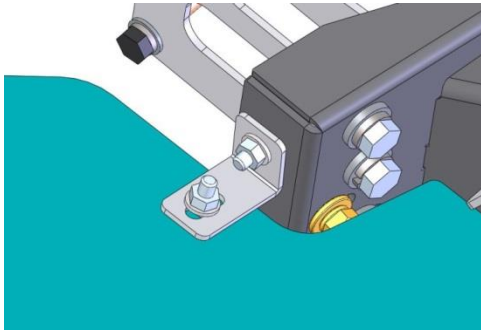
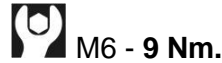

126. On each side of the bar attach the under wing panel to the mount bracket with the wing panel bracket using 2 x M8 x 25 hex bolts, 2 x M8 spring washers, 2 x M8 flat washers and 2 x M8 flange nuts.

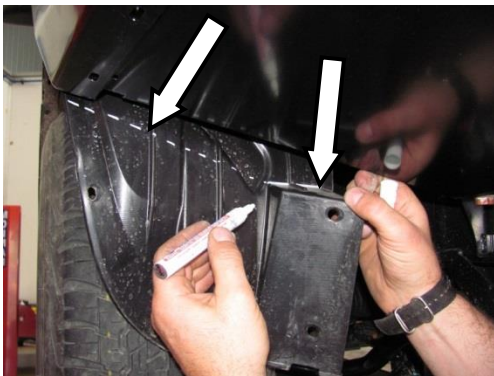
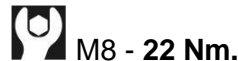

127. On the plastic OE inner guards, mark lines from the bottom corners of the bar wing tips down to the square corners in the inner guards. Continue the line along the horizontal corner.

128. Using scissors, sheers or a sharp knife, carefully cut along the marked line and discard the bottom section.

129. Push the inner guards inside the under wing panels.

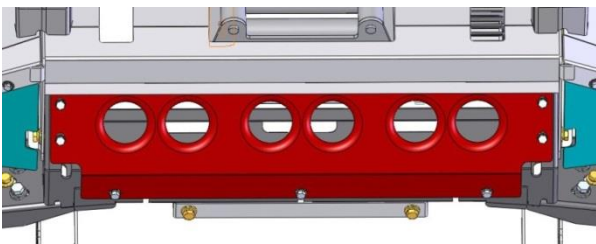

130. Attach the centre stone shield to the mount bracket using 7 x M8 x 25 hex bolts, 7 x M8 spring washers and 7 x M8 flat washers into the cage nuts fitted in step 85.

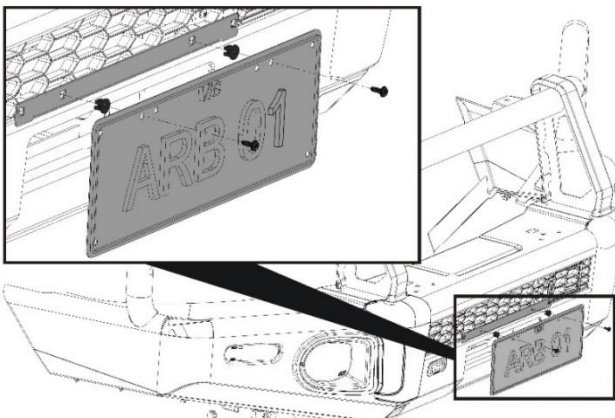
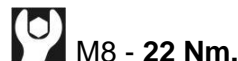

131. Fit the plastic plugs into the square holes in the licence plate bracket. Fit the number plate to the bull bar using the black self-tapping screws.

FITTED PRODUCT

