



FITTING INSTRUCTIONS

Part Number: **3438400**

Product **SUMMIT BULL BAR**

Description:

Suited to **NISSAN NAVARA NP300 (D23) '15 ONWARDS**
vehicle/s:

Optional Kits: **3500720** Winch Install Kit

3500640 ARB AUX Fog Light Adaptor

3500530 ARB AUX Fog Light Loom (non-factory fog lamp vehicles)

3500680 Fog Lamp Housing Clear Lens Kit

3500590 Fog Light Kit (LH&RH Lights)

WARNING

REGARDING VEHICLES EQUIPPED WITH SRS AIRBAG:

When installed in accordance with these instructions, the front protection bar does not affect operation of the SRS airbag.

ALSO, NOTE THE FOLLOWING:

- ◆ This product must be installed exactly as per these instructions using only the hardware supplied.
- ◆ In the event of damage to any bull bar component, contact your nearest authorised ARB stockist. Repairs or modifications to the impact absorption system must not be attempted.
- ◆ Do not use this product for any vehicle make or model, other than those specified by ARB.
- ◆ Do not remove labels from this bull bar.
- ◆ This product or its fixing must not be modified in any way.
- ◆ The installation of this product may require the use of specialized tools and/or techniques
- ◆ It is recommended that this product is only installed by trained personnel
- ◆ These instructions are correct as at the publication date. ARB Corporation Ltd. cannot be held responsible for the impact of any changes subsequently made by the vehicle manufacturer
- ◆ During installation, it is the duty of the installer to check correct operation/clearances of all components
- ◆ Work safely at all times
- ◆ Unless otherwise instructed, tighten fasteners to specified torque

ARB 4x4 ACCESSORIES

Corporate Head Office

42-44 Garden St
Kilsyth, Victoria
AUSTRALIA 3137

Tel: +61 (3) 9761 6622
Fax: +61 (3) 9761 6807

Australian enquiries
North & South American enquiries
Other international enquiries

sales@arb.com.au
sales@arbusa.com
exports@arb.com.au

www.arb.com.au

Last Rev Date: 10/04/2017

Page 1 of 21

Fitting instructions# 3789342

Copyright © 2005 by ARB Corporation Limited. All rights reserved, this document must not be reproduced without the express authority of ARB Corporation Ltd

GENERAL CARE AND MAINTENANCE

By choosing an ARB Bar, you have bought a product that is one of the most sought after 4WD products in the world. Your bar is a properly engineered, reliable, quality accessory that represents excellent value. To keep your bar in original condition it is important to care and maintain it following these recommendations:



- Prior to exposure to the weather your bar should be treated to a Carnuba based polish on all exposed surfaces. It is recommended that this is performed on a six monthly basis or following exposure to salt, mud, sand or other contaminants.
- As part of any Pre Trip Preparation, or on an annual basis, it is recommended that a thorough visual inspection of the bar is carried out, making sure that all bolts and other components are torqued to the correct specification. Also check that all wiring sheaths, connectors, and fittings are free of damage. Replace any components as necessary. This service can be performed by your local authorized ARB Stockist.

FITTING REQUIREMENTS

REQUIRED TOOLS FOR FITMENT OF PRODUCT:

BASIC TOOL KIT	ELECTRIC DRILL WITH COMPLETE METRIC DRILL SET
JIG SAW WITH BLADE SUITABLE FOR PLASTIC	LOW TACK MASKING TAPE
FILE	UTILITY KNIFE
TAPE MEASURE	CLAMP
STEEL RULER	WHITE FELT MARKER
HACK SAW	TORQUE WRENCH 9-77Nm
TOUCH UP PAINT ANTI CORROSION	RIGHT ANGLE ELECTRIC DRILL

HAVE AVAILABLE THESE SAFETY ITEMS WHEN FITTING PRODUCT:

Protective eyewear 	Hearing protection 
--	--

NOTE: 'WARNING' notes in the fitting procedure relate to OHS situations, where to avoid a potentially hazardous situation it is suggested that protective safety gear be worn or a safe work procedure be employed. If these notes and warnings are not heeded, injury may result.

FASTENER TORQUE SETTINGS:

SIZE	Torque Nm	Torque lbft
M6	9Nm	7lbft
M8	22Nm	16lbft
M10	44Nm	32lbft
M12	77Nm	57lbft

PARTS LISTING			
APPLICATION.	PART NO.	QTY	DESCRIPTION
FIT MOUNTS TO CHASSIS	4654045	1	MOUNT ASSEMBLY
	3759501R	1	BRKT CHASSIS RHS
	3759501L	1	BRKT CHASSIS LHS
	4654050	1	ASSEMBLY CAPTIVE NUTS M12x1.75
	6151360	4	BOLT M12 x 1.75 35mm Gd 8.8
	6151357	10	BOLT SEMS M10 x 1.5 x 30mm Gd 8.8
	4581007	5	WASHER FLAT M12 (4mm) SILVER TZP
	4581049	6	WASHER FLAT M12 (3mm) GOLD ZN
	4581050	4	WASHER SPRING M12 ZP
	6151321	10	NUT FLANGE M10 x 1.5 ZP
	6151428	2	NUT FLANGE M12 x 1.75 ZP
4581013	2	LOCATING WASHER	
FIT BAR TO MOUNTS	3438400	1	BULL BAR NAVARA NP300 (D23) '15 ON
	6151360	6	BOLT M12 x 1.75 x 35 Gd 8.8 ZP
	6151357	4	BOLT SEMS M10 X 30 ZP Gd 8.8
	4581050	6	WASHER SPRING M12 ZP
	4581007	6	WASHER FLAT M12 (4mm) SILVER TZP
	6151428	6	NUT FLANGE M12 X 1.75 ZP
	6151321	4	NUT FLANGE M10 x 1.5 ZP
FIT LIGHTS AND MOULDINGS	3500880	1	GRILLE SPLIT PAN KIT
	5100200	1	BUFF KIT 2PCE FRONT SECTION KIT
	5100210	1	BUFF KIT 2PCE REAR UPRIGHT BAR KIT
	6821287	1	LAMP LED INDICATOR CLEARANCE KIT
	3163082	1	SURROUND ARB FOGLIGHT KIT
	6821116	4	GROMMET NYLON SNAP IN TYPE
FIT STONE GUARDS	6522991	1	PANEL STONE TRAY BULLBAR NAVARA D23
	6522990R	1	PANEL WING BULLBAR NAVARA D23
	6522990L	1	PANEL WING BULLBAR NAVAR D23
	6151300	14	NUT CAGED M6 2.6-3.5
	6151546	8	BOLT HXHD M8 x 1.25 x 25 GR8.8 BTZP480
	6151711	14	SCREW BTN HD TX M6X25 BTZP480
	4581287	14	WASHER SPRING M6 x 2.5 x 1.6 BLK ZN
	4581047	8	WASHER SPRING M8 x 3/32 x 3/33 BLK ZN
	4581082	14	WASHER FLAT, M6 x 19 x 1.6 BZ
	4581075	20	WASHER FLAT, M8 BLK ZN
	4581303	4	WASHER FLAT, M8 LARGE O.D. (26mm)
	6151132	4	NUT FLANGE M8 x 1.25 ZP
	6151301	4	NUT CAGED M8
FIT WINCH COVER PANEL	6522985	1	PRESS FORM WINCH COVER PANEL
	6151213	4	BOLT M6 x 1.0 x 20 Gd8.8 BZ
	4581287	4	WASHER SPRING M6 x 2.5 x 1.6 BLK ZN
	4584295	4	WASHER FLAT M6 X 12 X 1.3 BLK ZN
	6151128	4	NUT FLANGE M6 x 1.0 ZP

FIT LICENSE PLATE	3759488	1	BRACKET LIC PLATE FIXED LARGE RAD
	6151384	2	SCREW 10G x 5/8 SELF TAPPING
	6821189	2	GROMMET RND FC 1500 080 090
	6151213	3	BOLT M6 x 1.0 x 20mm Gd 8.8 BZ
	4581287	3	WASHER SPRING M6 x 2.5 x 1.6 BLK ZN
	4584295	3	WASHER FLAT M6 x 12 x 1.3 BLK ZN
	6151128	3	NUT FLANGE M6 x 1.0 ZP
MISCELLANEOUS	6191025	2	PINCH WELD 480mm
	3789345	1	BUMPER CUT TEMPLATE
	180302	8	CABLE TIE 4.8 x 180mm BLACK

FITTING PROCEDURE

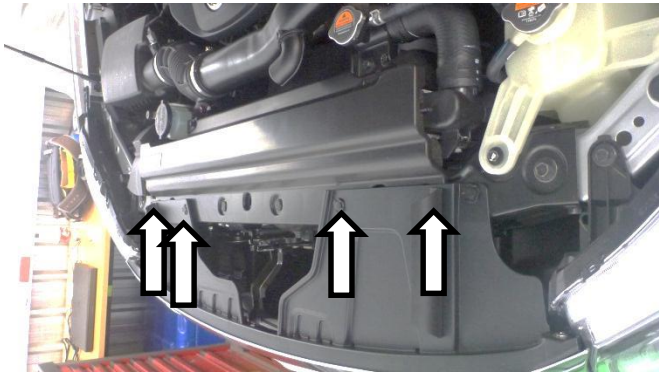

Note: Read the instructions thoroughly before starting.

1. Open the bonnet and remove all skivets retaining grille.

Set aside skivets removed for re-use later on.



2. Remove grille (clipped in).

Set aside for re-fitment later on.



3. Remove all fasteners and scrivets retaining bumper along inside edge of wheel arches.

Set aside for re-fitment later on.

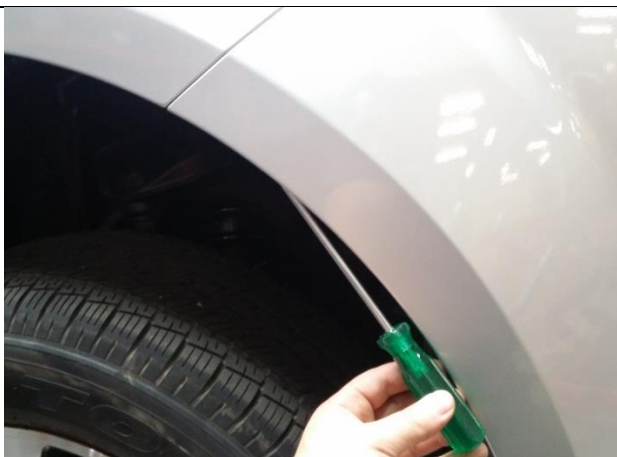

4. Take note location of hidden screw located at top corner of bumper near wheel arch.



5. Remove all scrivenets retaining bumper along top edge of bumper.

Set aside for re-fitment later on.



6. Remove dressing piece from underside of bumper and discard.



7. Remove all fasteners and scrivenets retaining bumper along lower lip.

Set aside scrivenets and fasteners used to attach bumper to OEM stone deflector for re-use later on.



8. Carefully remove bumper from vehicle by pulling on each side of the bumper near the wheel arches and working your way towards the centre.

Whilst detaching the bumper from vehicle, disconnect all wiring relating to fog lights and/or parking sensors.

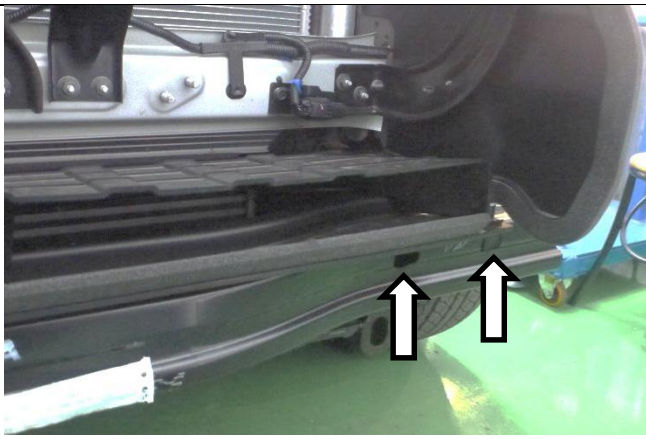

9. Remove 2x M12 bolts on both sides (4 total) fixing crash beam to chassis and remove crash beam.

Discard of crash beam.

Retain 4x M12 bolts for re-use.

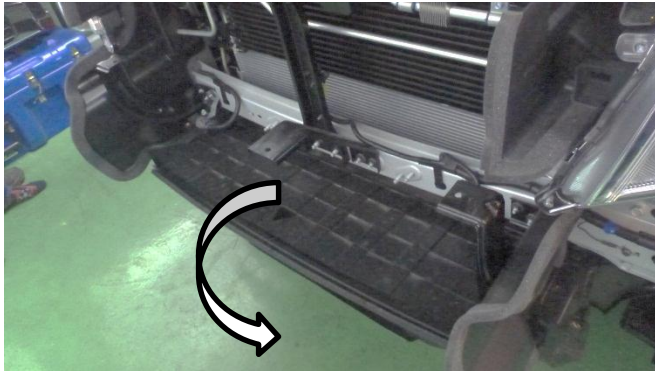

10. Remove intercooler duct and discard.



11. Using a white felt marker and the bumper bracket as a guide, mark a curved line onto inside face of ir deflector.

12. Repeat for opposite side.



13. Carefully cut along marked lines of air deflectors using a hack saw or jig saw and discard of front sections cut off.

Take care not to damage any other components on the vehicle whilst cutting.



Warning: Drilling operations can result in flying metal debris, safety glasses should be worn.

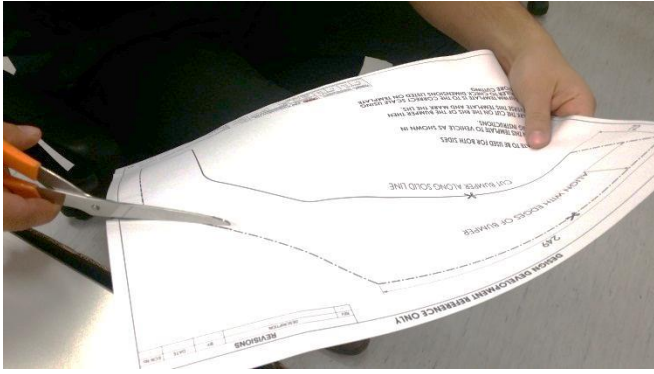

14. Carefully cut out bumper cut template supplied.

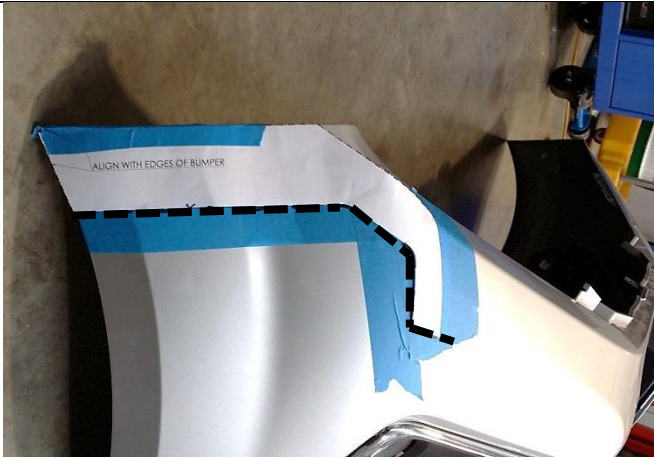

15. Position template onto RHS of bumper aligning with edges of bumper specified on template.

Stick masking tape onto bumper at area underneath template as shown.

Using a permanent marker, outline edges of bumper cut template onto masking tape where the bumper cut will be performed.

Remove template and repeat the above for LHS. Take care not to rip template upon removal.

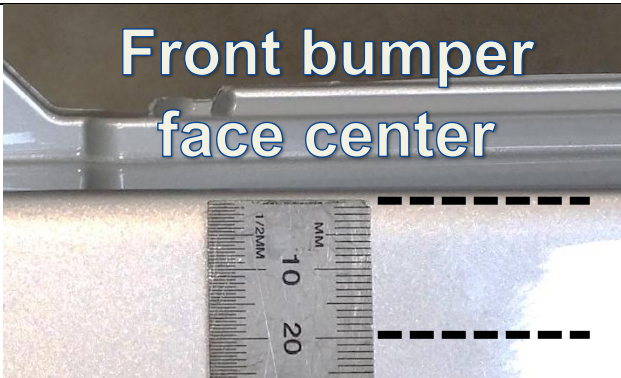

16. Apply a generous amount of masking tape across top front section of bumper.

Mark line onto center of bumper 20mm below top lip.

Using the outlined edges created in the previous step as a guide, draw a continuous line that is projected onto the bumper front as per the dimensions shown.

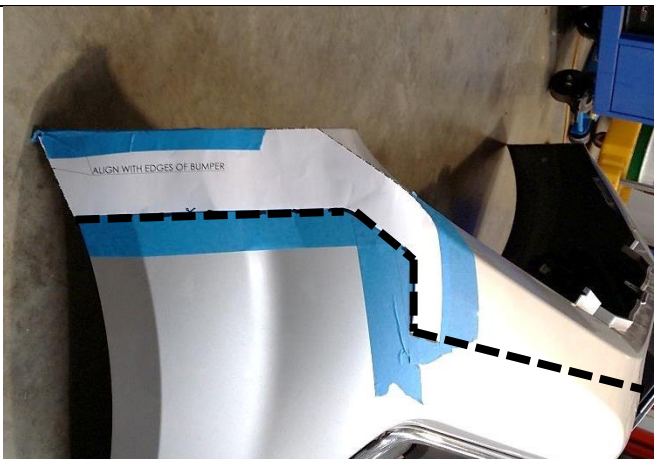

17. Using the outlined edges created in the previous steps as a guide, draw a continuous line that is projected onto the bumper front connecting centre marked line and outer marked lines.



FRONT VIEW



18. Carefully cut bumper along marked lines using a hack saw or jig saw and remove all masking tape.

Dispose of lower section of cut bumper.



Warning: Drilling operations can result in flying metal debris, safety glasses should be worn.



19. Apply bumper trim pinch weld to both sides of cut edges as shown and cut off any excess length.

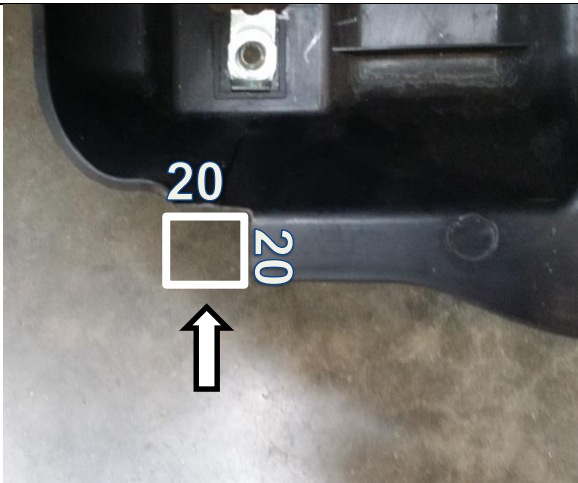

20. Carefully cut a 20x20mm section out of both sides of OEM stone deflector at front corners using a pair of side-cutters.



21. Remove OEM tow hook by unbolting 2x M12 bolts fixing it to underside of LHS chassis rail.

Set aside OEM tow hook and M12 bolts for re-use.



22. Insert M12x1.25 captive nut assembly into RHS chassis rail as shown.

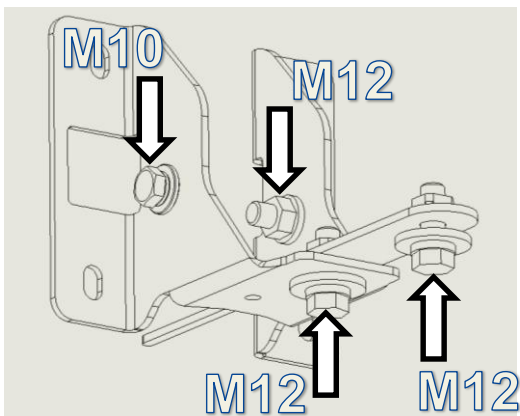

23. Loosely fasten RHS chassis bracket to chassis using 2x M12x1.75x35mm bolts, 2x ½" spring washers and 2 x ½" flat washers (4mm thick) for underside of chassis.

Loosely fasten 1x M12x1.75x30mm bolt, 1x M12 spring washer, 1x M12 flat washer (4mm thick) and 1x M12 flange nut to outside face of chassis.

Loosely fasten 1x M10x1.5x30mm SEMS bolt assembly and M10x1.5 flange nut to inside face of chassis.

Move chassis bracket as far forward as possible and then tighten starting with bolts on underside of chassis.

Note: LH & RH chassis brackets are symmetrical to each other.



M12 – 77Nm



M10 – 44Nm



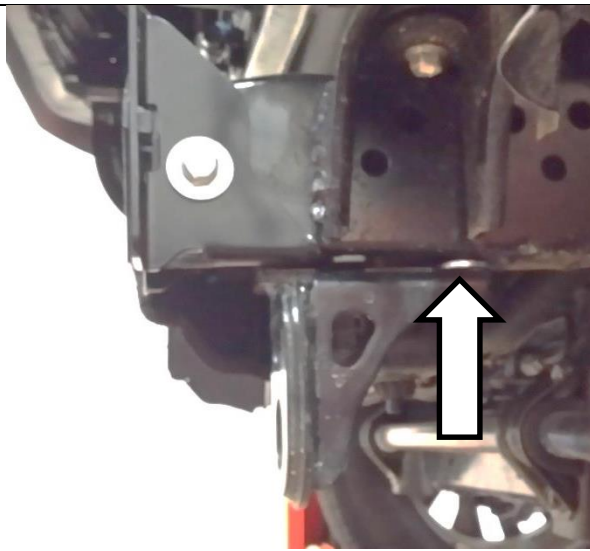

24. Loosely fasten LHS chassis bracket to chassis using 1x M10x1.5x30mm SEMS bolt assembly and M10x1.5 flange nut to inside face of chassis as well as 1x M12x1.75x35mm bolt, 1x M12 spring washer and 1x M12 flat washer (4mm thick) to outside face of chassis.

Using two existing OEM M12 bolts set aside in step 21, loosely fasten OEM tow point back to underside of chassis.

Note: Fit a M12 washer (4mm thick) between OEM tow point and chassis at rear-most M12 bolt to fill the extra spacing added from chassis bracket.

Move chassis bracket as far forward as possible and then tighten starting with bolts on underside of chassis.



M12 – 77Nm



M12 (OE) – 109Nm



M10 – 44Nm

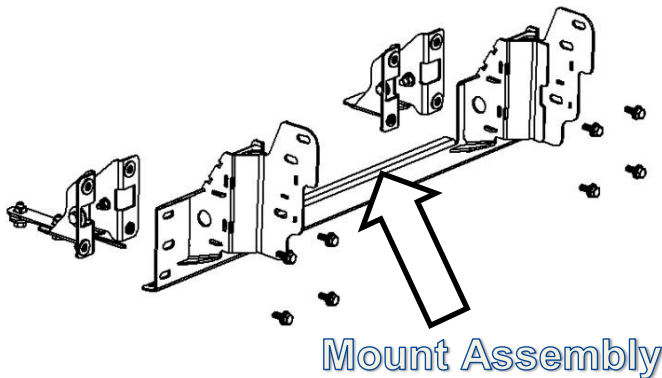

25. With the assistance of a second person, lift the mount assembly towards chassis brackets and loosely fasten to chassis mount brackets using 8x M10x1.5x30mm SEMS bolt assemblies and 8x M10x1.5 flange nuts.

Whilst feeding bolts through, position 6x M12 washers between mount assembly and chassis brackets and 2x locating washers at innermost bottom corners (as shown).

Loosely fasten the 4x M12 OEM bolts retained in step 9 to captive nuts in chassis.

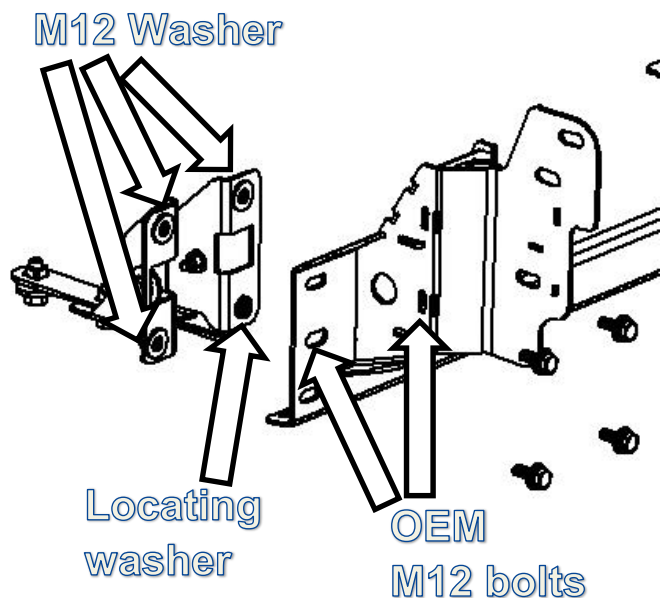

FITTING PROCEDURE

Note: If fitting a winch proceed from here using fitting instructions 3789337 supplied with 3500720 winch install kit. Once the winch is fitted please continue to step 29. If no winch is being fitted continue from here.

26. Slide the winch cover panel from the bottom up until it is level with the top face of the bar.

27. Fit the winch cover panel to the bar using 4 x M6 x 20 hex bolts, spring washers, flat washers and flange nuts.

Warning: Be careful not to scratch the finish of the winch cover panel.

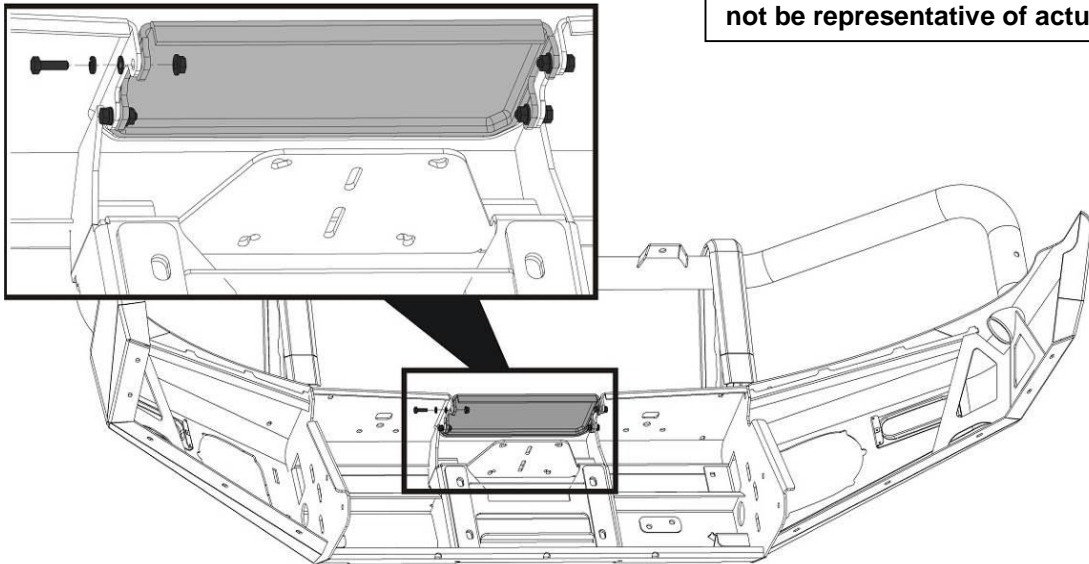

28. Fit the number plate bracket to the top face of the lower-centre pan on the bar using 3 x M6 x 20 hex bolts, spring washers, flat washers and flange nuts.

Note: If you are fitting a winch, fit the folding number plate bracket supplied in winch install kit "3500720 WINCH INSTALL KIT" – See fitting instructions 3789337

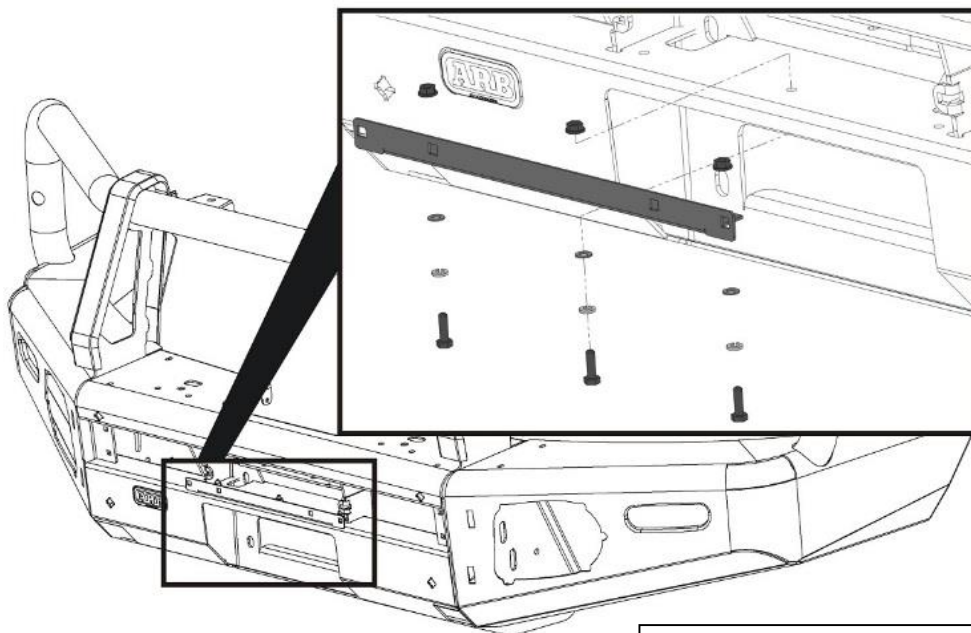

Note: The following steps show the fitment of the plastic moulded parts. The mouldings are supplied in kits along with all fasteners required for fitment. It is important that the fasteners supplied with each kit are only used for the mouldings from the same kit. The kits included in this bar kit are as follows:

29. Layout the contents of each of the following kits ensuring the contents are kept separate from each other.

Kit No.	Description
5100200	BUFF KIT 2PCE FRONT SECTION
5100210	BUFF KIT 2PCE REAR UPRIGHT BAR
3500880	SPLIT PAN MESH KIT
3163082	FOG SURROUND KIT

30. Mark the grille panel to be cut at the 760mm marks at each end on the back face.

Note: When marked, double check the measurement with a measuring tool.

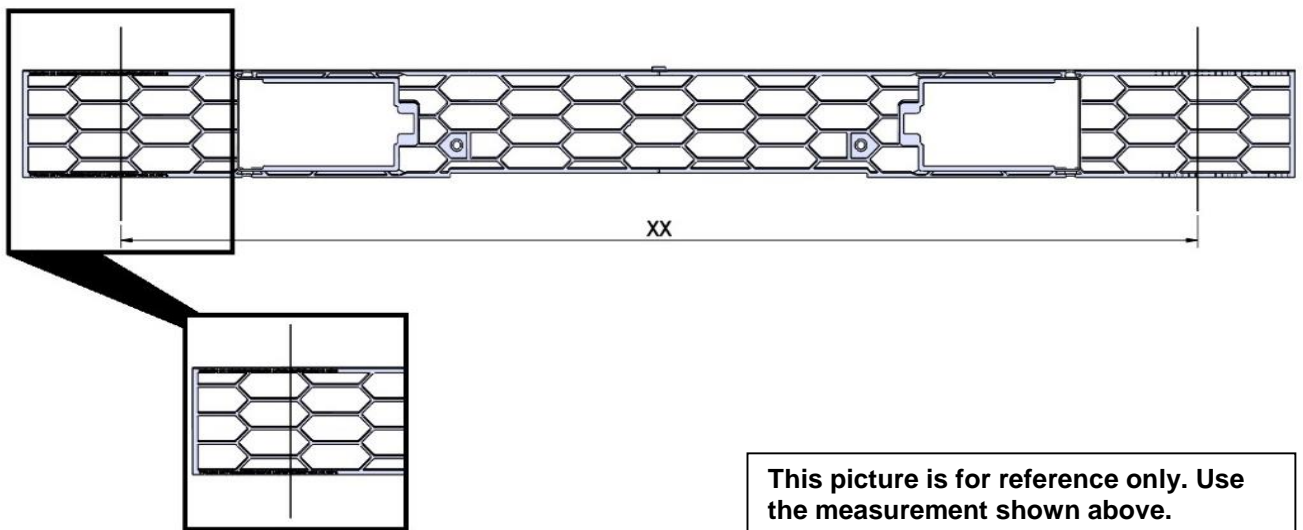

31. Use a hacksaw or similar cutting tool to carefully cut the grille panel at the positions marked in the step above.

32. Discard the off cuts and clean up the cut edges using a file or sandpaper.

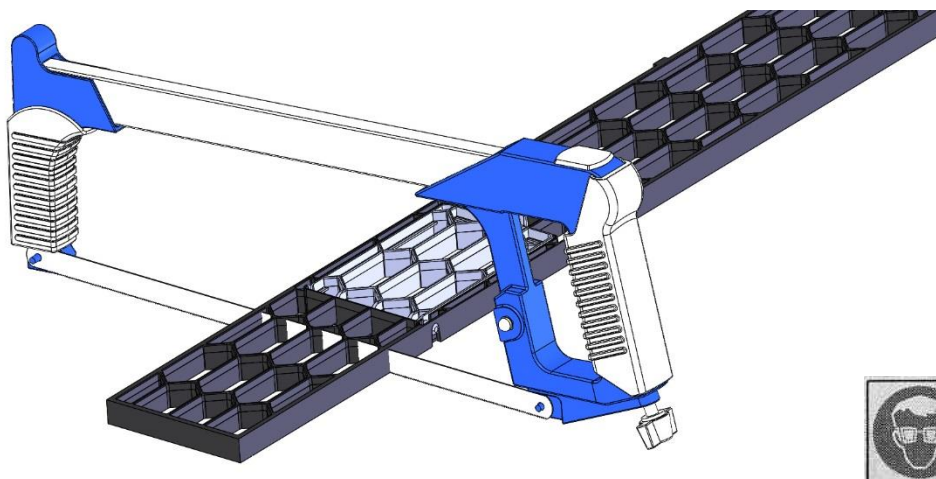

33. Insert the 6 x plastic grommets into the 6 square holes in the front face of the bar.
34. Insert the grille into the bar so that the hatches open outward (facing the front of the bar).
35. Attach the grille to the centre of the bar using the short screws into the grommets fitted above.
36. Attach the ends of the grille to the bar using the longer screws, through the clamp plates into the remaining grommets.

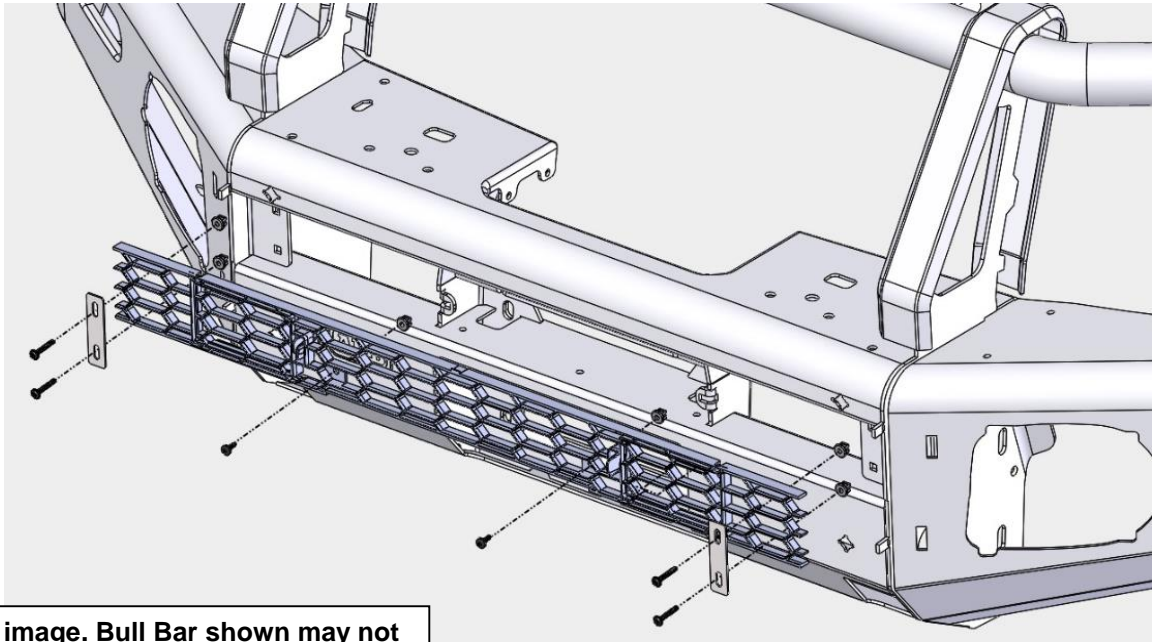

Generic image. Bull Bar shown may not be representative of actual product.

37. Fit the rubber intersection mouldings to the base of each upright cover strap.

Generic image. Bull Bar shown may not be representative of actual product.

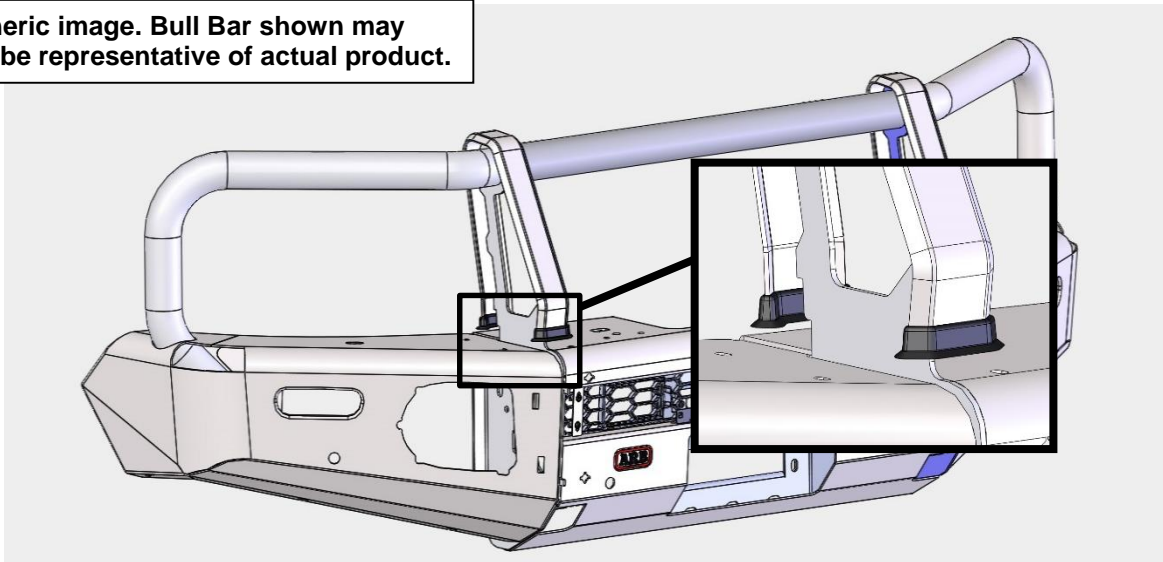

38. From the rear of the bar, slide the rear buffer sections under the rubber mouldings.

Fit 4 x screws and washers. Do not tighten screws. Leave enough play in buffers for adjustment later.

Note: Ensure that the skirts of the rubber intersection mouldings are not folded back on themselves and are sitting flat against the buffers.

Generic image. Bull Bar shown may not be representative of actual product.

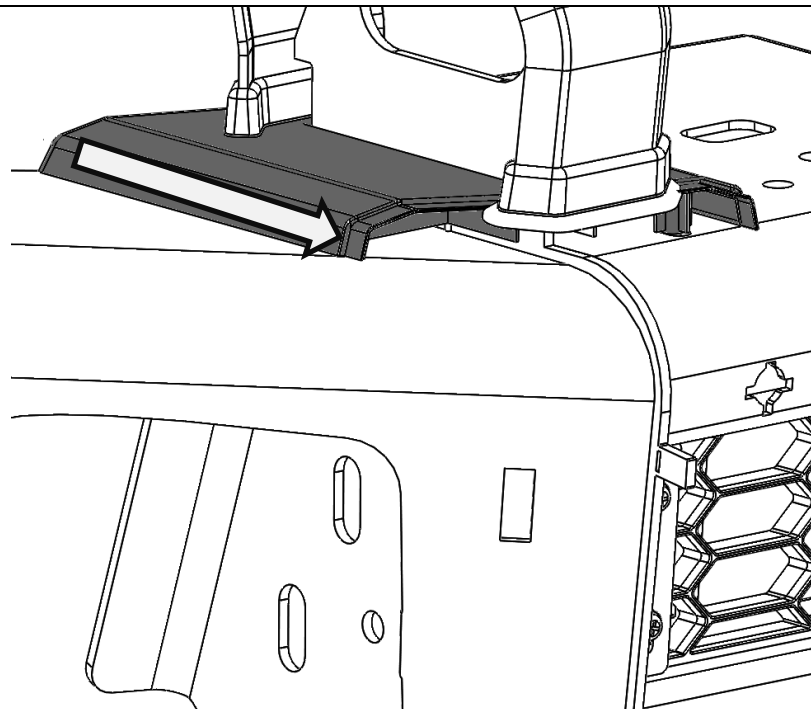

Fit washers under screw heads

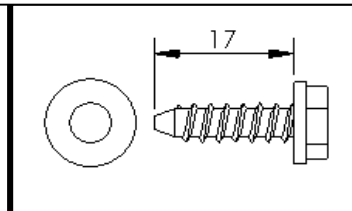

39. By aligning the front buffer with the tongue of the rear buffer, attach the front buffers to the front face of the bar. Ensure each buffer sits flat against the face of bar and is keyed into the top section of the rear buffer.

Secure wing side using retaining clips.

Secure inner side using the angled cup washers, flat washers and screws.

The widest point of the cup washers goes to the top of the bar.

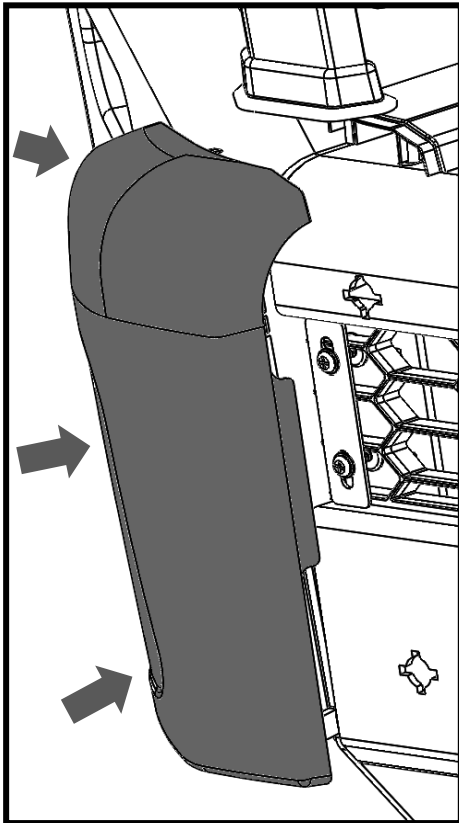

Generic image.
Bull Bar shown
may not be
representative of
actual product.

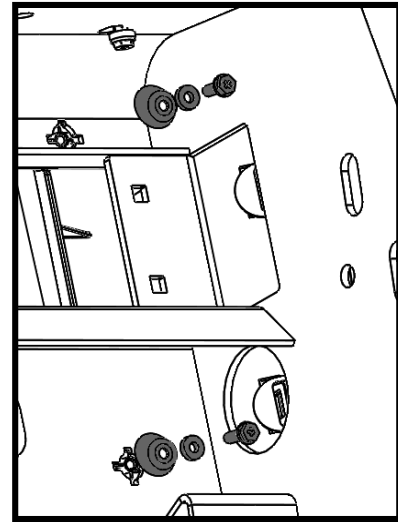

Fit washers under screw heads.

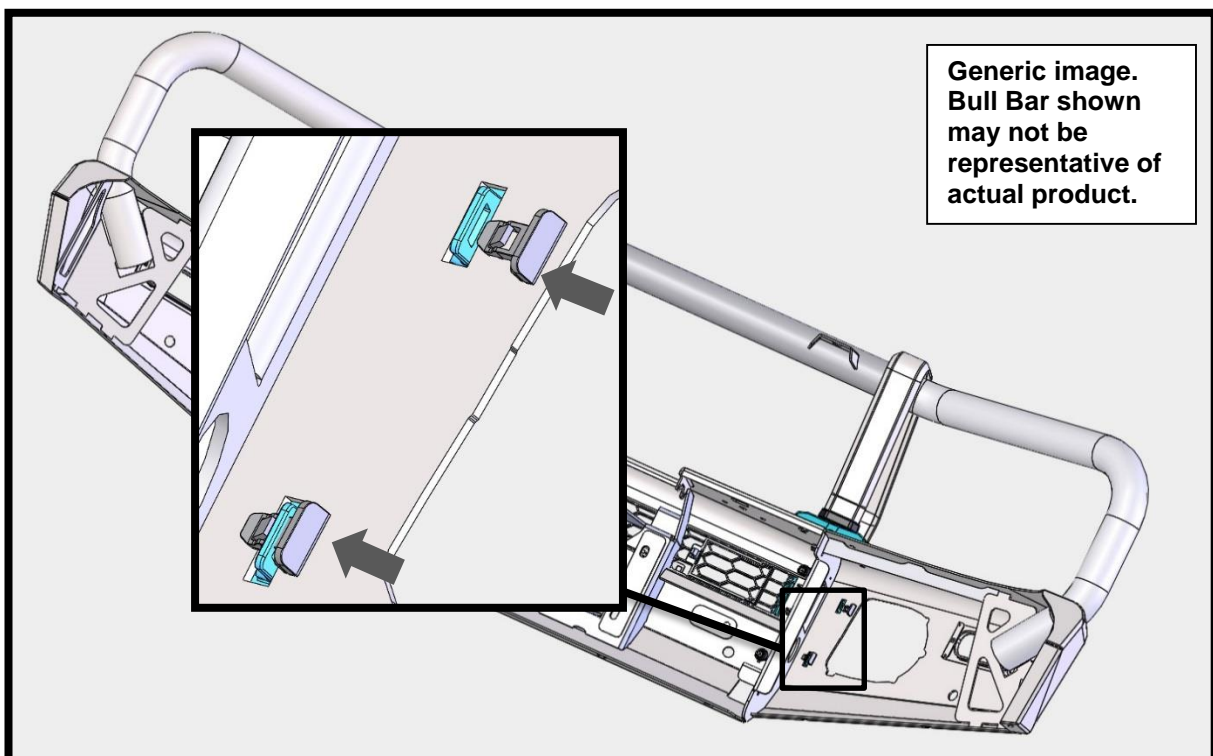
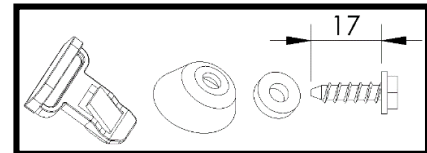

Generic image.
Bull Bar shown
may not be
representative of
actual product.

FITTING PROCEDURE

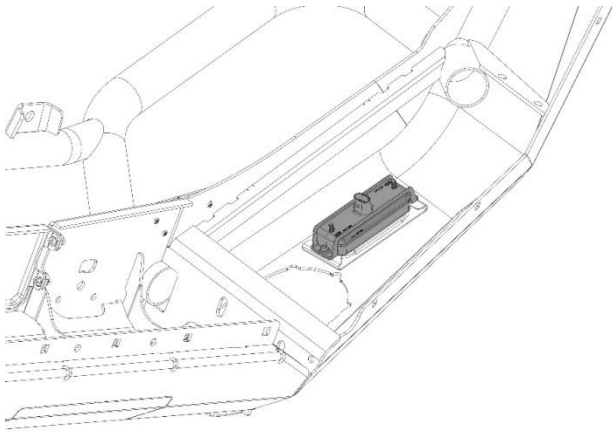

40. Fit the small plastic grommets to the bar and attach the combination LED lamps to the bar using the screws provided with the lamp kit.
41. Wire the combination lamp (kit: 6821287) to the vehicles indicator and clearance lamp wiring.
Caution: Cable tie all cables together and keep all cables clear of sharp edges and moving parts.

Wiring:
Red wire is Turn signal + (pos)
Black is – (neg)



42. With the assistance of another person, place the bar on the mount brackets.

Warning: Due to the weight of the bar and winch if fitted, it is advised that you use some form of mechanical assistance when lifting the bar onto the vehicle such as an elevating trolley.

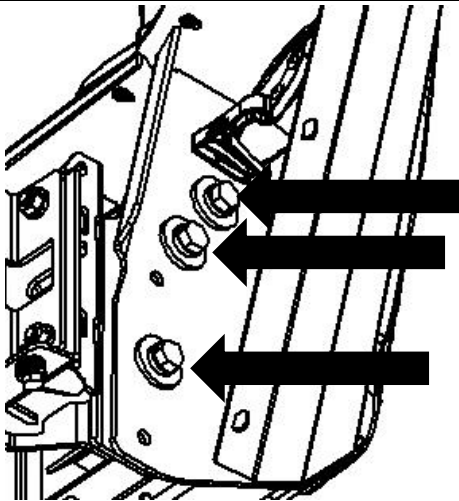

43. Loosely fasten bar to mounts using 6x M12x1.75x35mm bolts, 6x M12 spring washers, 6x M12 flat washers (4mm thick) and 6X M12 flange nuts.

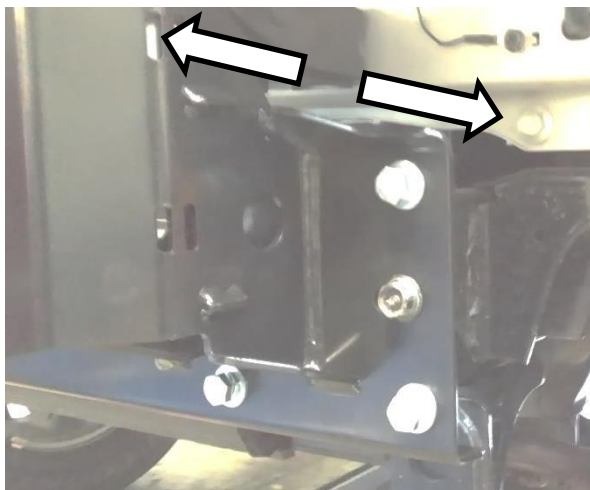

44. Adjust position of bar left/right until it's sitting central to body, then tighten all fasteners joining mount assembly to chassis brackets (4x M10 and 2x M12 bolts each side).

 M12 – 77Nm

 M10 – 44Nm



45. Position the bar so that it's level with the bumper cut profile as shown and there is an even gap of 15-22mm between the wing edge and bumper cut trim.
46. Once bar is visually in correct position, tighten 6x M12 fasteners joining bull bar to mount assembly.

 M12 – 77Nm

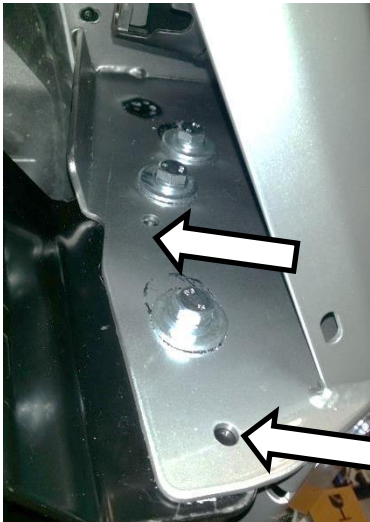

47. Drill 4x Ø11mm holes (2 per side) through mount assembly using existing holes in bull bar as guide.
48. Add anti-corrosion touch up paint to area drilled.
49. Fasten 4x M10 SEMS bolts and flange nuts to pinning holes.

Note: Due to tight space, an angled electric drill is preferred.

 M10 – 44Nm



Warning: Drilling operations can result in flying metal debris, safety glasses should be worn.



50. Assemble and install combination light surrounds (p/n 3163082) as per instructions no. 3789190 supplied with surround kit. Note: Optional fog lamps can be installed at this point as per fitting instruction supplied with fog lamp kit no. 6821201.

CAUTION: Cable-tie all cables together and keep all cables clear of sharp edges and all moving parts.

51. Check the operation of all lights wired during bar fitment

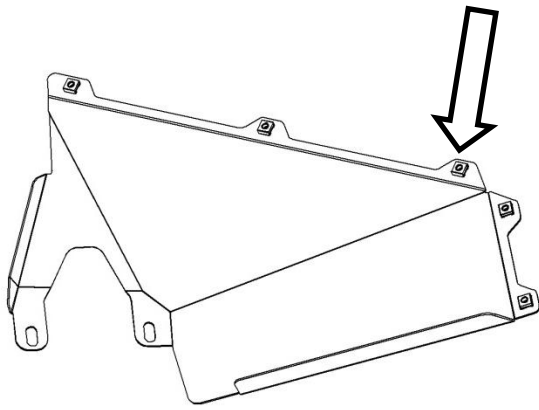

52. Fit 5x M6 cage nuts to each wing under panel.

Note: Cage nut heads to be located on top side.

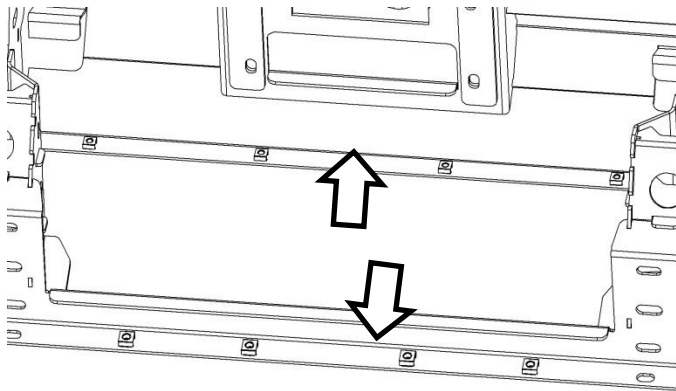

53. Fit 4x M6 cage nuts to bull bar and 4x M8 cage nuts to mount assembly as shown.

Note: Cage nut heads to be located on top side of bull bar lip and mount assembly.



54. Using holes in the mount assembly as guide, mark 2x hole positions onto OEM stone deflector.

55. Drill 2x Ø11mm holes where marked.



Warning: Drilling operations can result in flying metal debris, safety glasses should be worn.

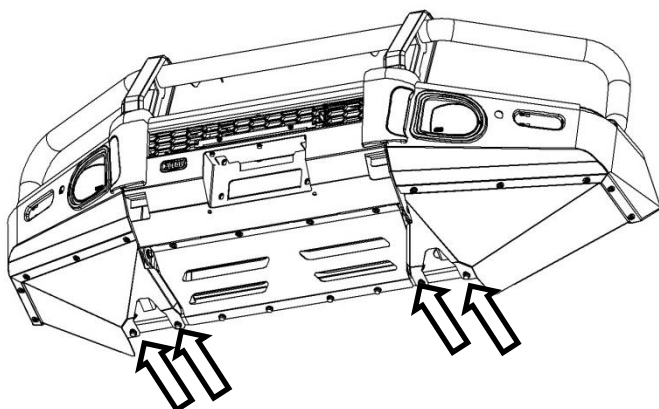

56. Fasten stone tray and wing under panels to bull bar using 14x button head screws, 14x M6 spring washers, 14x M6 flat washers, 8x M8x1.25x25mm bolts, 8x M8 spring washers, 20x M8 flat washers, 4x M8 flat washers large O.D. (26mm) and 4x M8 flange nuts.

Note: If recovery point is not fitted, position 4x M8 washers between wing under panel and mount assembly at each location shown to fill spacing.

Note: Use large O.D. (26mm) M8 washers at bolt head onto wing underpanel.

Note: OEM stone deflector sits between stone tray and mount assembly.

 M6 – 9Nm  M8 – 22Nm



57. Mark lines onto the OEM inner guards (LH & RH) using wing under panels as guide ensuring enough guard remains so that it may be neatly tucked/secured behind wing under panel lip.

58. Carefully cut along marked lines using jig-saw.



Warning: Drilling operations can result in flying metal debris, safety glasses should be worn.

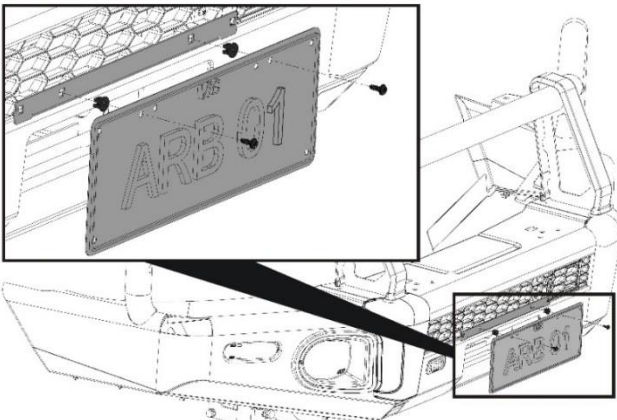

59. Fit the plastic plugs into the square holes in the licence plate bracket. Fit the number plate to the bull bar using the black self-tapping screws.

60. Discard of all remaining fasteners left over.

FITTED PRODUCT – Nissan NP300 (D23) Summit bull bar

