



FITTING INSTRUCTIONS

Part Number: **3423210 | 6178462 | 6178463**
Product **ZENITH WINCH BAR | SUIT TACOMA MY24 ON**
Description:
Suited to **TOYOTA TACOMA MY24 ON**
vehicle/s: **SR5, TRD PreRunner, TRD Sport, TRD Off-Road and Limited**

Optional **W89965** WARN ZEON EXTENDED CABLE KIT
Fitting Kits: **W106928** KIT WIRE EXTENSION VR EVO
3500410 WARN XDC ADAPTER KIT
3500770 SMITTYBILT ADAPTER KIT

WARNING

REGARDING VEHICLES EQUIPPED WITH SRS AIRBAG:

When installed in accordance with these instructions, the front protection bar does not affect operation of the SRS airbag.

ALSO, NOTE THE FOLLOWING:

- ◆ This product must be installed exactly as per these instructions using only the hardware supplied.
- ◆ In the event of damage to any bull bar component, contact your nearest authorised ARB stockist. Repairs or modifications to the impact absorption system must not be attempted.
- ◆ Do not use this product for any vehicle make or model, other than those specified by ARB.
- ◆ Do not remove labels from this bull bar.
- ◆ This product or its fixing must not be modified in any way.
- ◆ The installation of this product may require the use of specialized tools and/or techniques.
- ◆ It is recommended that this product is only installed by trained personnel.
- ◆ These instructions are correct as at the publication date. ARB Corporation Ltd. cannot be held responsible for the impact of any changes subsequently made by the vehicle manufacturer.
- ◆ During installation, it is the duty of the installer to check correct operation/clearances of all components.
- ◆ Work safely at all times.
- ◆ Unless otherwise instructed, tighten fasteners to specified torque.

ARB 4x4 ACCESSORIES

Corporate Head Office

42-44 Garden St
Kilsyth, Victoria
AUSTRALIA 3137

Tel: +61 (3) 9761 6622
Fax: +61 (3) 9761 6807

Australian enquiries
North & South American enquiries
Other international enquiries

sales@arb.com.au
sales@arbusa.com
exports@arb.com.au

www.arb.com.au

GENERAL CARE AND MAINTENANCE

By choosing an ARB Bar, you have bought a product that is one of the most sought after 4WD products in the world. Your bar is a properly engineered, reliable, quality accessory that represents excellent value. To keep your bar in original condition it is important to care and maintain it following these recommendations:



- Prior to exposure to the weather your bar should be treated to a Carnauba based polish on all exposed surfaces. It is recommended that this is performed on a six-monthly basis or following exposure to salt, mud, sand or other contaminants.
- As part of any Pre-Trip Preparation, or on an annual basis, it is recommended that a thorough visual inspection of the bar is carried out, making sure that all bolts and other components are torqued to the correct specification. Also check that all wiring sheaths, connectors, and fittings are free of damage. Replace any components as necessary. This service can be performed by your local authorized ARB Stockist.

FITTING REQUIREMENTS

REQUIRED TOOLS FOR FITMENT OF PRODUCT:

BASIC TOOL KIT	ELECTRIC DRILL WITH COMPLETE METRIC DRILL SET
JIG SAW OR OSCILATING MULTITool WITH BLADE SUITABLE FOR PLASTIC	LOW TACK MASKING TAPE
FILE	UTILITY KNIFE
TAPE MEASURE	CLAMP
STEEL RULE	WHITE FELT MARKER
HACK SAW	TORQUE WRENCH
TOUCH UP PAINT ANTI CORROSION	RIGHT ANGLE ELECTRIC DRILL
BLACK SPRAY PAINT OR BLACK SELF-ADHESIVE VINYL	

HAVE AVAILABLE THESE SAFETY ITEMS WHEN FITTING PRODUCT:

Protective eyewear 	Hearing protection 
--	--

NOTE: 'WARNING' notes in the fitting procedure relate to OHS situations, where to avoid a potentially hazardous situation it is suggested that protective safety gear be worn or a safe work procedure be employed. If these notes and warnings are not heeded, injury may result.

FASTENER TORQUE SETTINGS:

SIZE	Torque Nm	Torque lbft
M6	9Nm	7lbft
M8	22Nm	16lbft
M10	44Nm	32lbft
M12	102Nm	68lbft

WINCH COMPATIBILITY:

WINCH MODEL	ADDITIONAL KITS
Zeon 8:	W89965 WARN ZEON EXTENDED CABLE KIT
Zeon 8s:	W89965 WARN ZEON EXTENDED CABLE KIT
Zeon 10:	W89965 WARN ZEON EXTENDED CABLE KIT
Zeon 10s:	W89965 WARN ZEON EXTENDED CABLE KIT
Zeon 12:	W89965 WARN ZEON EXTENDED CABLE KIT
Zeon 12s:	W89965 WARN ZEON EXTENDED CABLE KIT
Zeon 10 Platinum:	W89965 WARN ZEON EXTENDED CABLE KIT
Zeon 10-s Platinum:	W89965 WARN ZEON EXTENDED CABLE KIT
Zeon 12 Platinum:	W89965 WARN ZEON EXTENDED CABLE KIT
Zeon 12-s Platinum:	W89965 WARN ZEON EXTENDED CABLE KIT
VR EVO 8:	W106928 KIT WIRE EXTENSION VR EVO
VR EVO 8s:	W106928 KIT WIRE EXTENSION VR EVO
VR EVO 10:	W106928 KIT WIRE EXTENSION VR EVO
VR EVO 10s:	W106928 KIT WIRE EXTENSION VR EVO
VR EVO 12:	W106928 KIT WIRE EXTENSION VR EVO
VR EVO 12s:	W106928 KIT WIRE EXTENSION VR EVO
XP:	-
XP:	-
M8000:	-
M8000s:	-
XD9:	-
XD9s:	-
9.5XDC:	3500410 WARN XDC ADAPTER KIT
9.5XDC-s:	3500410 WARN XDC ADAPTER KIT
Bushranger REVO MKII 10W:	-
Bushranger REVO MKII 10S:	-
Bushranger REVO MKII 12W:	-
Bushranger REVO MKII 12S:	-
Bushranger Covert 10-w:	-
Bushranger Covert 10-s:	-
Bushranger Covert 12-w:	-
Bushranger Covert 12-s:	-
Smittybilt X20 10lbs cable:	3500770 SMITTYBILT ADAPTER KIT
Smittybilt X20 10lbs rope:	3500770 SMITTYBILT ADAPTER KIT
Smittybilt X20 12lbs cable:	3500770 SMITTYBILT ADAPTER KIT
Smittybilt X20 12lbs rope:	3500770 SMITTYBILT ADAPTER KIT

PARTS LISTING

APPLICATION	PART NO.	QTY	DESCRIPTION
OEM BUMPER	37800295	1	ZEN CUT TMPLT SUIT TACOMA
	6191030	1	PINCH WELD 520mm
	37500460R	1	ZEN BMPR RET BRKT RHS
	37500460L	1	ZEN BMPR RET BRKT LHS
	6821189	4	GROMMET RND FC 1500 080 090
	6151338	4	SCREW PHD 4.8x2.1x20 BTZP HI/LOW

APPLICATION	PART NO.	QTY	DESCRIPTION
MOUNTS TO VEHICLE	4655694	1	ZEN MNT WELD ASSY SUIT TACOMA
	37500336R	1	BRKT INNER CHAS SUIT J250 RH
	37500336L	1	BRKT INNER CHAS SUIT J250 LH
	37500337R	1	BRKT OUTER CHAS SUIT J250 RH
	37500337L	1	BRKT OUTER CHAS SUIT J250 LH
	3197056	2	ZEN RP SPCR LRG SUIT TACOMA
	6151817	6	BOLT HXHD FL M12x1.25x40 PC11.9 ZAB1000
	6151480	4	NUT FLANGE M12x1.25 PC8.8 TZP480 SERRATED
	4617103	2	CHASSIS CRUSH TUBE
	6152092	2	BOLT HXHD M12x1.75x110 PC 10.9 ZAS1000
	6151528	2	NUT HEX NYLOC M12x1.75 PC10.9 ZP
	4584412	10	WASHER FLAT M12x24x2.5 HV300 ZNB480

APPLICATION	PART NO.	QTY	DESCRIPTION
RECOVERY POINTS	4655695R	1	ZEN REC POINT FORGED RHS
	4655695L	1	ZEN REC POINT FORGED LHS
	6151817	8	BOLT HXHD FL M12x1.25x40 PC11.9 ZAB1000
	6151480	6	NUT FLANGE M12x1.25 PC8.8 TZP480 SERRATED
	4584412	8	WASHER FLAT M12x24x2.5 HV300 ZNB480
	2125484	2	RECOVERY POINT WARNING LABEL

APPLICATION	PART NO.	QTY	DESCRIPTION
CAMERA AND SENSORS	37500416	1	ZEN CAM BRKT SUIT TACOMA
	6151443	4	SCREW BHD M6x20 BZP
	4584329	6	WASHER FLAT M6x12.2x1.2 BTZP480
	6151173	2	NUT FLANGE M6 ZNB480 SERRATED
	6151223	4	NUT HEX NYLOC M6x1.0 ZNB480
	3163222	2	PLUG SNSR BLANKING PAIR
	3525010	1	SENSOR SURROUND KIT (4) SUITS LC300
	6821451	4	HARNESS EXTENSION SUITS TOYOTA

APPLICATION	PART NO.	QTY	DESCRIPTION
BAR TO MOUNTS	3197138	8	ZEN MOUNT SHIM SUIT TACOMA
	6151443	4	SCREW BHD M6x20 BZP
	4584329	4	WASHER FLAT M6x12.2x1.2 BTZP480
	6151817	4	BOLT HXHD FL M12x1.25x40 PC11.9 ZAB1000
	4584412	4	WASHER FLAT M12x24x2.5 HV300 ZNB480
	6151480	4	NUT FLANGE M12x1.25 PC8.8 TZP480 SERRATED
	6151965	4	BOLT HXHD FL M10x1.5x30 PC8.8 ZNB480
	4581040	4	WASHER FLAT M10x25x3 TZP480
	6151752	4	NUT FLANGE M10x1.5 PC8.8 BTZP480

APPLICATION	PART NO.	QTY	DESCRIPTION
GRILLE	37800352	1	ZEN GRILLE CUT TEMPLATE
	3163400	3	ZENITH BAR CENTER GRILLE
	37500433R	1	ZEN GRLL BRKT OUTER RHS
	37500433L	1	ZEN GRLL BRKT OUTER LHS
	6151142	4	SCREW ST PHD 10Gx3/4 ZP REC
	37500434	4	ZEN GRLL RTN BRKT LWR RHS
	6151921	12	BOLT COHD M8x20 ZNB480 LWHD
	4581085	12	WASHER FLAT M8x19x1.2 ZNB480
	6151212	12	NUT HEX NYLOC M8x1.25 ZNB480
	6821189	8	GROMMET RND FC 1500 080 090
	6151338	8	SCREW PHD 4.8x2.1x20 BTZP HI/LOW

APPLICATION	PART NO.	QTY	DESCRIPTION
WINCH FITMENT	37500426	1	ZEN CNTRL BOX BRKT SUIT TACOMA

APPLICATION	PART NO.	QTY	DESCRIPTION
VEHICLE COMPONENTS MOUNTED TO BASH PLATE	37500327	1	RADAR BRKT UPPER SUIT J250
	37500328	1	RADAR BRKT LOWER SUIT J250
	6151443	4	SCREW BHD M6x20 BZP
	4584329	8	WASHER FLAT M6x12.2x1.2 BTZP480
	6151223	2	NUT HEX NYLOC M6x1.0 ZNB480
	6151584	2	BOLT HXHD M6x1.0x40 PC8.8 BTZP
	5670069	2	SPRING COMP STAINLESS 25X6.0ID
	4584421	2	WASHER FLAT M6X18X1.6 NYLON
	6821189	8	GROMMET RND FC 1500 080 090
	6151142	8	SCREW ST PHD 10Gx3/4 ZP REC

APPLICATION	PART NO.	QTY	DESCRIPTION
NUMBER PLATE BRACKET	37500431	1	NUM PLATE BRKT F150 ZENITH
	37500417R	1	ZEN LIC PLT BRKT RHS SUIT TACOMA
	37500417L	1	ZEN LIC PLT BRKT LHS SUIT TACOMA
	6151443	8	SCREW BHD M6x20 BZP
	4584329	14	WASHER FLAT M6x12.2x1.2 BTZP480
	5848302	2	PACKER RB NYLON
	6151223	6	NUT HEX NYLOC M6x1.0 ZNB480
	6151173	2	NUT FLANGE M6 ZNB480 SERRATED

APPLICATION	PART NO.	QTY	DESCRIPTION
BASH PLATE TO BAR/MOUNTS	4655693	1	BASH PLATE SUIT TACOMA ZENITH
	3197138	8	ZEN MOUNT SHIM SUIT TACOMA
	3197055	3	ZEN RP SPCR SML SUIT TACOMA
	6151965	4	BOLT HXHD FL M10x1.5x30 PC8.8 ZNB480
	4581040	7	WASHER FLAT M10x25x3 TZP480
	6151752	4	NUT FLANGE M10x1.5 PC8.8 BTZP480
	6151888	3	SCREW PHD TX M10X1.5X30 S01-108 ZTS480T
	6151304	3	NUT CAGED M10 3.3-4.7 1231-C

APPLICATION	PART NO.	QTY	DESCRIPTION
OUTER GRILLES	3163390R	1	DUCT MOULDING OUTER RH SUIT ZENITH
	3163390L	1	DUCT MOULDING OUTER LH SUIT ZENITH
	3163395R	1	DUCT MOULDING INNER RH SUIT ZENITH
	3163395L	1	DUCT MOULDING INNER LH SUIT ZENITH
	6151173	20	NUT FLANGE M6 ZNB480 SERRATED

APPLICATION	PART NO.	QTY	DESCRIPTION
WING BRACES	4681900R	1	ZEN WNG BRC BOLTED SUIT TACOMA
	4681900L	1	ZEN WNG BRC BOLTED SUIT TACOMA
	6151730	8	BOLT HXHD FL M8x1.25x20 FT PC8.8 BZP480 ENS14-001
	6151655	8	NUT FLANGE M8x1.25 PC8 TZP480 ENS 14/002

APPLICATION	PART NO.	QTY	DESCRIPTION
UNDER PANELS	6523692	1	ZEN STONE TRAY SUIT TACOMA
	6523691R	1	ZEN WING PANEL RHS SUIT TACOMA
	6523691L	1	ZEN WING PANEL LHS SUIT TACOMA
	6151975	3	SCREW BHD M6x12 SS
	4581072	3	WASHER FLAT M6x20x1.6 TZP
	6151315	3	NUT CAGED M6 0.7-1.6 956-A
	6152008	6	BOLT HXHD FL M6x1.0x25 PC8.8 ZNB480
	4584329	6	WASHER FLAT M6x12.2x1.2 BTZP480
	6151475	6	NUT U M6x1.0 TZP480 PR1.6-3.0 L13
	6151730	2	BOLT HXHD FL M8x1.25x20 FT PC8.8 BZP480 ENS14-001
	6151655	2	NUT FLANGE M8x1.25 PC8 TZP480 ENS 14/002

APPLICATION	PART NO.	QTY	DESCRIPTION
MISC	180302	8	CABLE TIE 4.8 X 180 MM BLACK

FITTING PROCEDURE

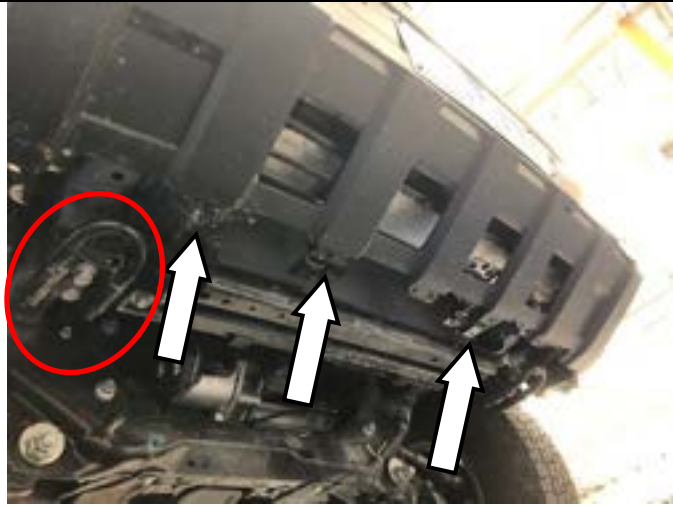

1. Remove the bolts underneath the bumper and discard.
2. Remove OEM tow points. Discard tow points, but retain bolts for later use.



3. Remove the clips & screws holding the front half of the wheel arch liners.
Carefully unclip the front of the wheel arch liners.



4. Open the bonnet and remove all scrivets (8) retaining plastic cover. Set aside scrivets removed for re-use later on.

TIP: Depress centre to remove.



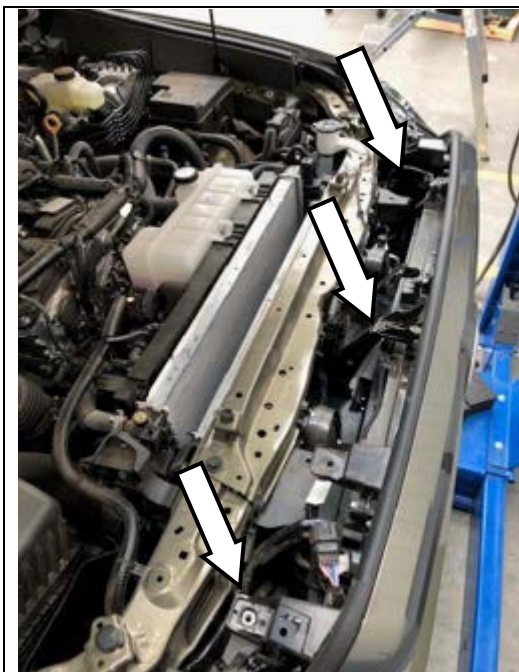

5. Remove the three bolts across the top of the radiator support connected to the grille.
6. Disconnect the electrical connectors on either side of the grille.



7. Gently peel back flare unclipping it from inside the bumper, revealing a silver screw. Remove and retain screw for re-fitment.
Repeat for the other side.



8. Unclip the corners of the bumper from the vehicle. Remove the bumper and set aside on a soft surface to avoid scratching it.
9. Unclip plastic section from the crash beam.



10. Remove the eight bolts securing the crash beam to the chassis.
11. Remove the alloy crash beam and discard.
12. Remove lower air deflector between front chassis crossmember and AC condenser.

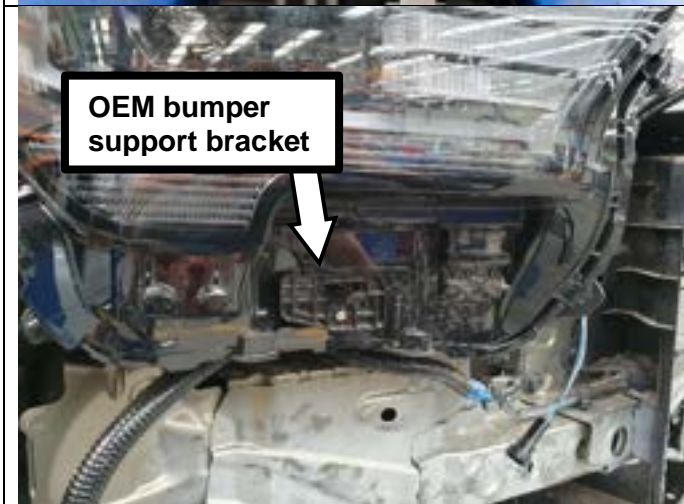
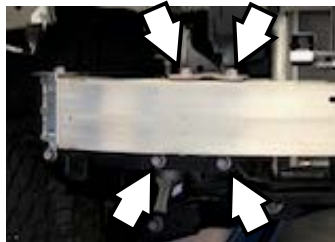

OEM bumper support bracket

13. Remove OEM bumper support bracket to exchange with Zenith bumper support bracket. Use same OEM fastener. Brackets fit one way only, right hand shown.

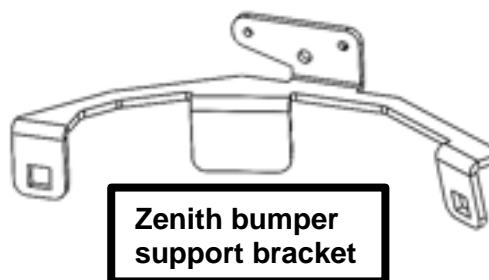

Zenith bumper support bracket

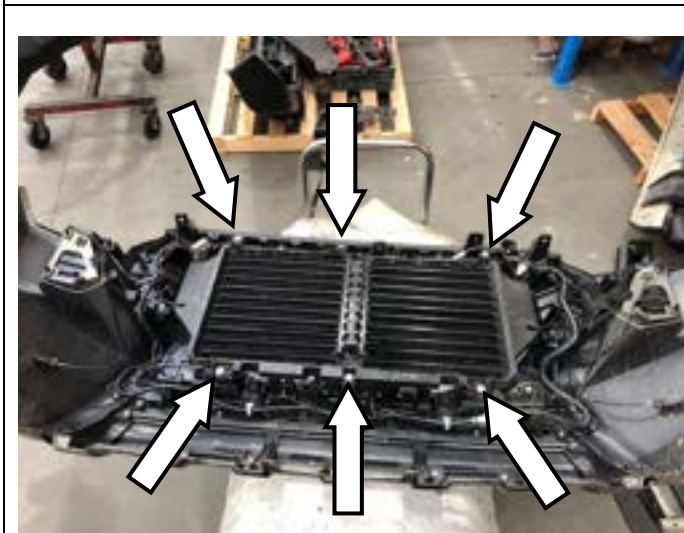

14. Remove six M6 bolts holding the OEM air shutter assembly.



15. Unclip the loom from the lower half of the bumper.
16. Remove radar, camera and fog lamps from bumper.
17. Remove and label parking sensors (right outer, right inner, left outer and left inner).

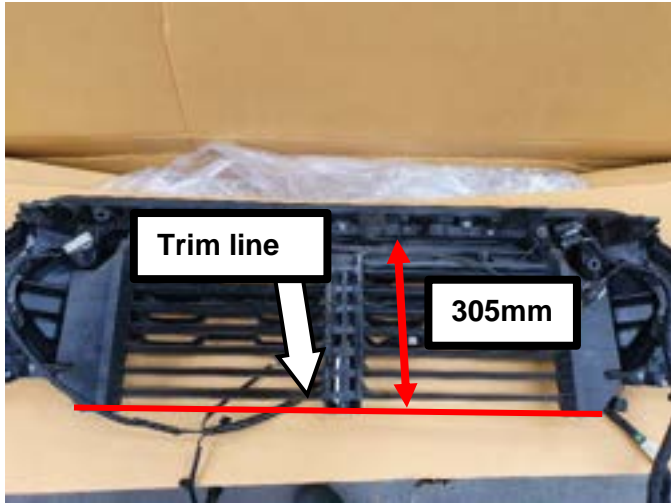

18. Trim active grille shutter 305mm below the top edge of the device, leaving the motor and the louvre it is directly attached to intact.
19. Fit grille shutter back to bumper with original three upper OEM M6 bolts.

Note: Trimmed bumper shown for reference; bumper trimming occurs in later steps.



20. Confirm correct sizing of template by measuring the scale provided.
21. Cut out flare cut template.

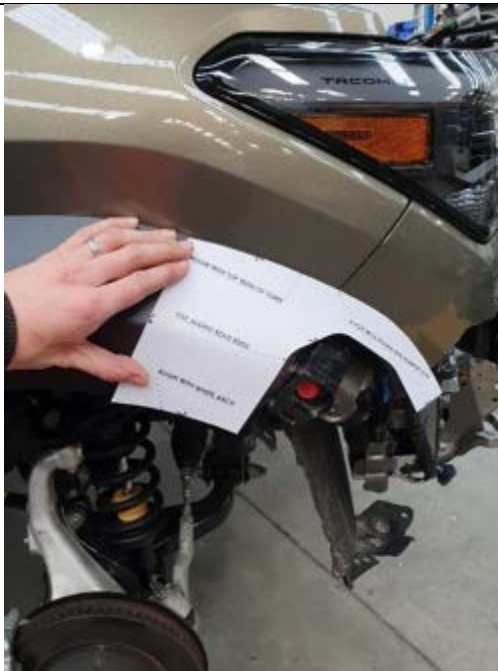

22. Cover flare cut region with masking tape to mark out cut path.
23. Place cut template on masked flare and trace cut path onto flare. Retain template to use on other side.

Repeat for other side.

Top edge of flare.

Fender and bumper join as described on template.

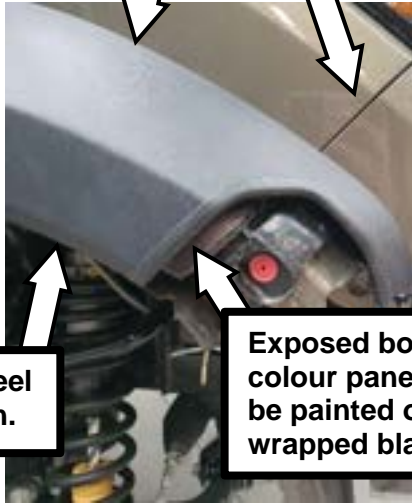

Wheel arch.

Exposed body colour panel to be painted or wrapped black.

24. Cut flare to templated marking and apply pinch weld to the cut edge as shown.
25. Remove trimmed flares and use black paint or vinyl to cover body colour section exposed by flare trim.



26. Re-fit the bumper and flares as it is much easier to trim the bumper on the vehicle.

27. Mark across the grille and bumper as shown in red, connecting to the edge of the templated cut on the flare shown in blue. Cut through all bumper layers. Mirror cut for other side.

The cut from the centre of the vehicle to point A should follow the grille features as shown. The cut from point A to point B should be marked as a straight line (aided by a steel rule) from the corner of the grille shown (point A), at 110mm down from the headlight, through to the bumper feature at point B. A straight line can then be marked from point B through to the end of the templated flare cut at point C.

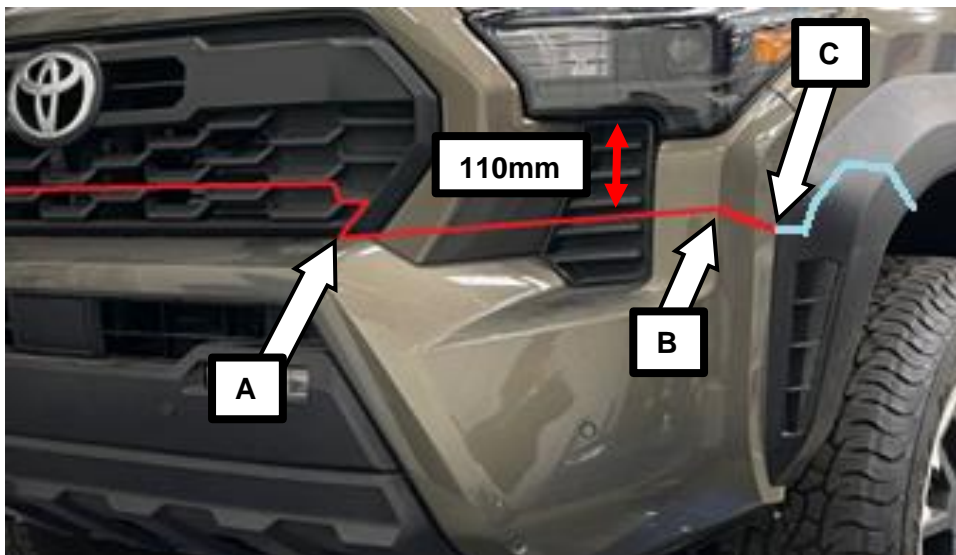

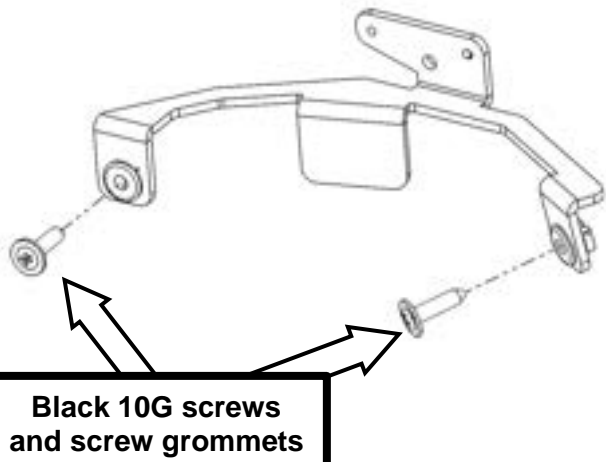

**Black 10G screws
and screw grommets**

28. Secure trimmed bumper to bumper retention brackets using two 10G black screws and two screw grommets through the bumper. Right hand side shown.

Repeat for other side.



**Plastic grommet
on outer face of
chassis rail**

29. Remove the three forwardmost plastic grommets on the chassis rails. One on chassis rail outer face, one on inner face and one on lower face.

Repeat for other side.

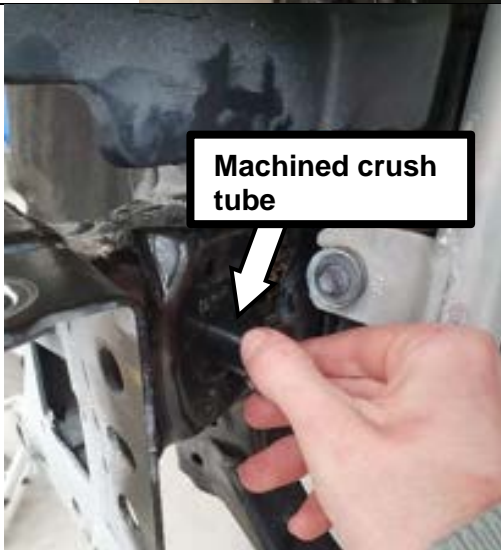

**Machined crush
tube**

30. Identify and fit a machined crush tube into each chassis rail (RHS and LHS) from the inside.

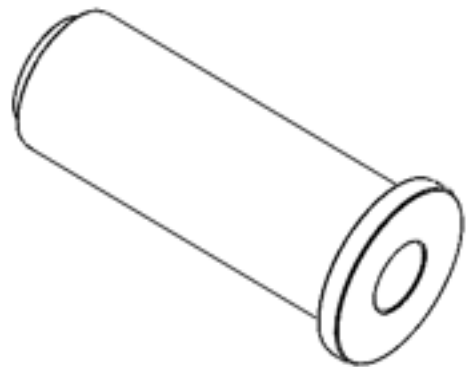

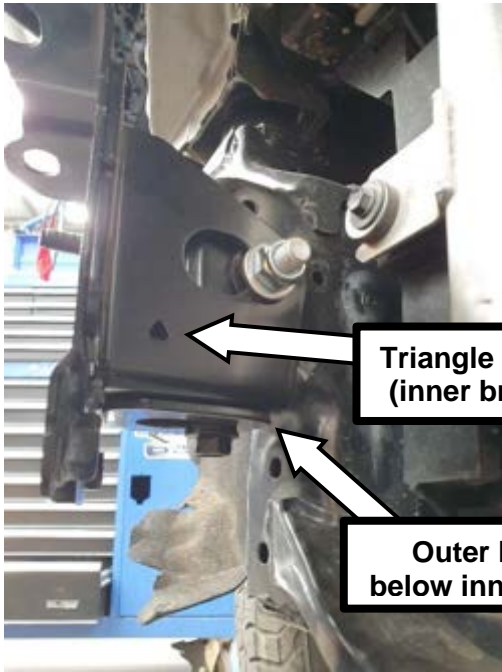

**Triangle cutout
(inner bracket)**

**Outer bracket
below inner bracket**

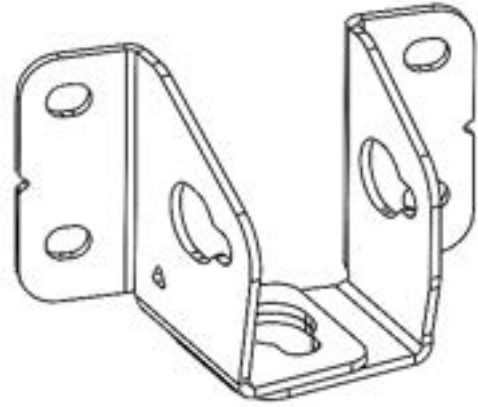

RHS Chassis Support Brackets

31. Identify and fit the chassis support brackets to the chassis rails and hold in place with the M12x1.25x40mm bolt, washer and serrated nut in bottom face. Note orientation of two brackets, right hand side shown. Triangle cutout identifies inner bracket. Leave fasteners finger tight.



**M12x1.75x110mm bolt,
M12 washers and
M12x1.75 Nyloc nut.**

32. Install one M12x1.75x110 bolt, two M12 washers and a M12 Nyloc nut to each crush tube (two crush tubes). Leave fasteners finger tight.



33. Sit the winch cradle in place on the end of the chassis rails as shown. Use studs on front of chassis rail to help location.

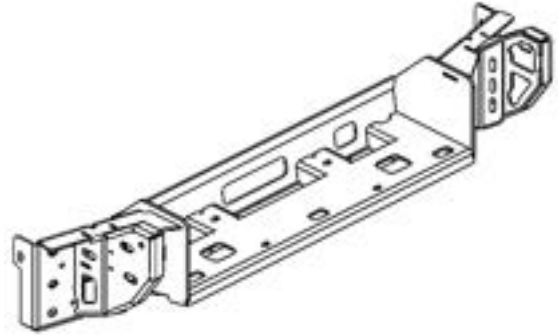

M12x1.25x40mm flange bolt, M12 washer and M12 flange nut
(finger tight)

M12x1.25x40mm flange bolt and M12 washer
(torque to spec)

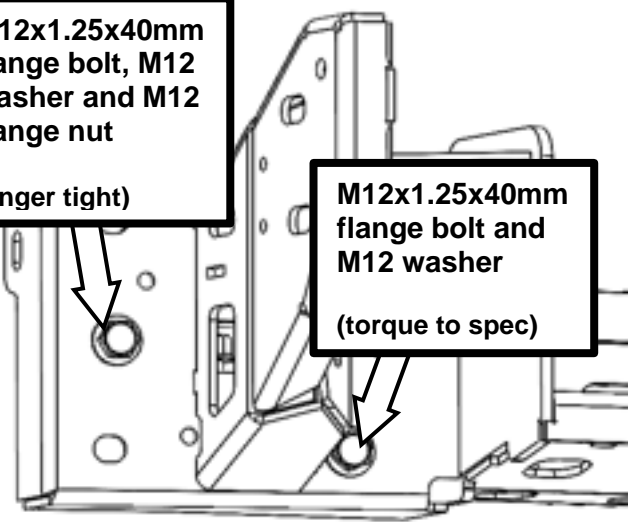

34. Install two M12x1.25x40mm flange bolts, two M12 washers one M12 flange nut and two 2-hole spacers, to secure winch cradle to chassis. Leave outer fasteners (nut and bolt) loose, but torque bolt into captive nut to spec.

 M12 - 102 Nm

2-hole spacer

Insert spacer here

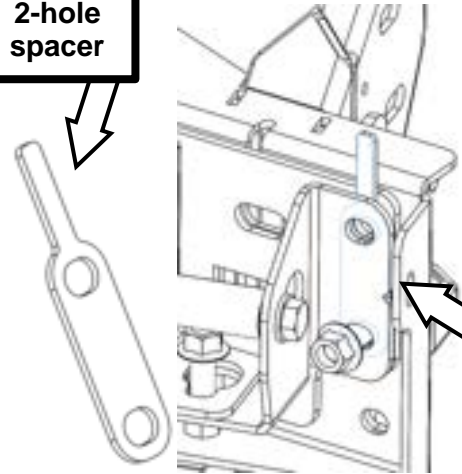

M12x1.25x40mm flange bolt, M12 washer and flange nut

M12x1.25x40mm flange bolt and washer

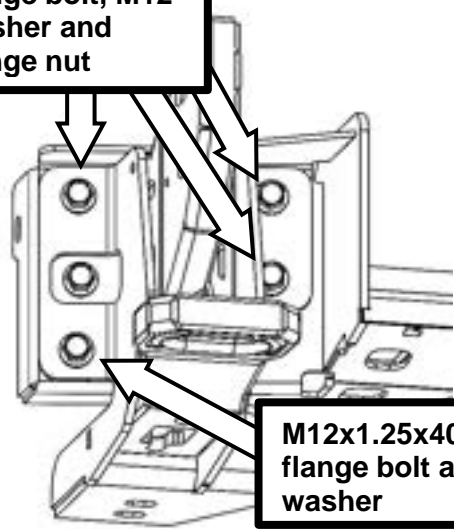

35. Install recovery point using four M12x1.25x40mm bolts, four M12 washers and three M12 flange nuts. Leave fasteners loose. Right hand side shown.

Repeat for other side.

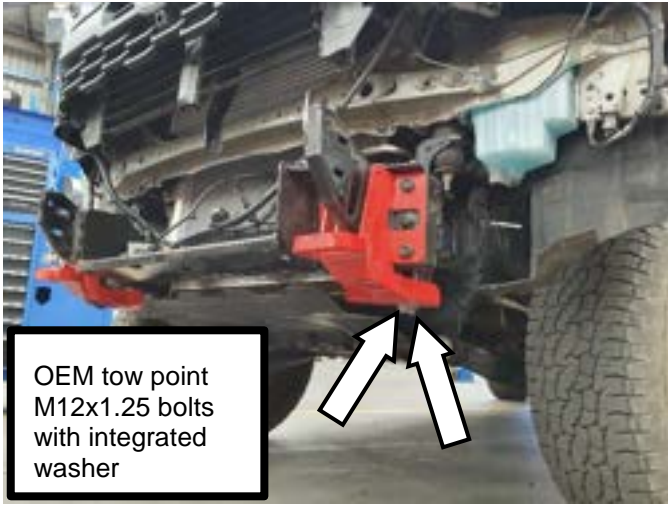

OEM tow point
M12x1.25 bolts
with integrated
washer

36. Install two OEM tow point M12x1.25 bolts with integrated washer removed in step 2. Left hand side shown. Leave fasteners loose.

Repeat for other side.

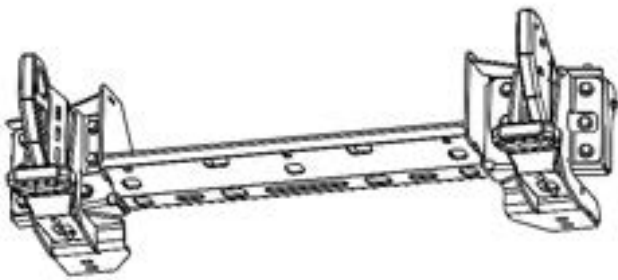

37. With all mount and recovery fasteners fitted, tighten all fasteners to specification.



SIZE	Torque Nm	Torque lbft
M10	44Nm	32lbft
M12	102Nm	68lbft

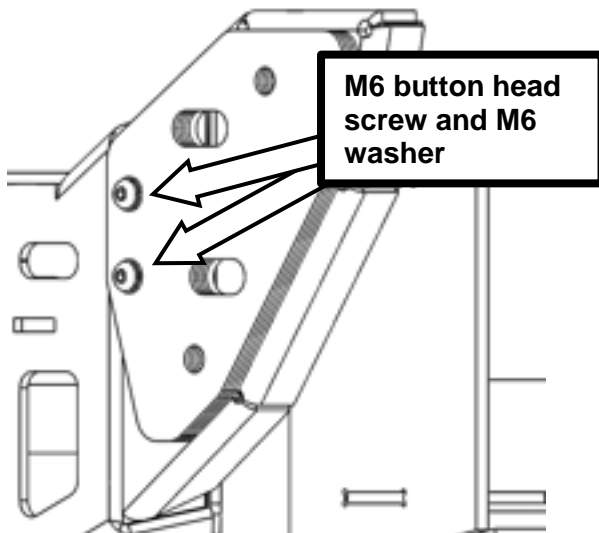

M6 button head
screw and M6
washer

38. Install mount shims to the mount using two M6x20 button head bolts with M6 washers. Torque to spec.

Start with 2 shims per side.

Repeat for other side.



M6 - 9 Nm

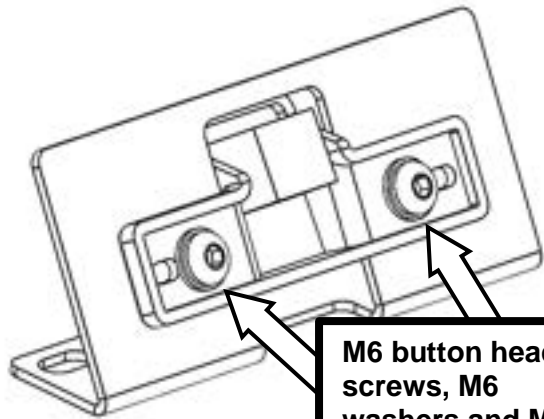

M6 button head screws, M6 washers and M6 Nyloc nuts

39. Fit camera to bracket using two M6 button head screws, four M6 washers and two M6 Nyloc nuts. Tighten until firm taking care to not damage plastic camera bracket.

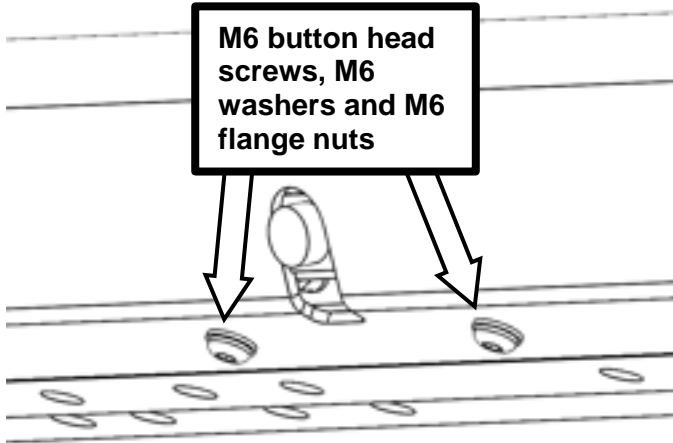

M6 button head screws, M6 washers and M6 flange nuts

40. Fit bracket with camera to the bar using two M6 button head screws, two M6 washers and two M6 flange nuts. Torque to spec.

 M6 - 9 Nm



41. Fit bar to vehicle using lifting aid such as an elevating trolley.

Plug in the camera.

Ensure tight fit to mount shims. If a gap is present or bar does not fit on mounts, remove bar from vehicle to add/remove shims as required.

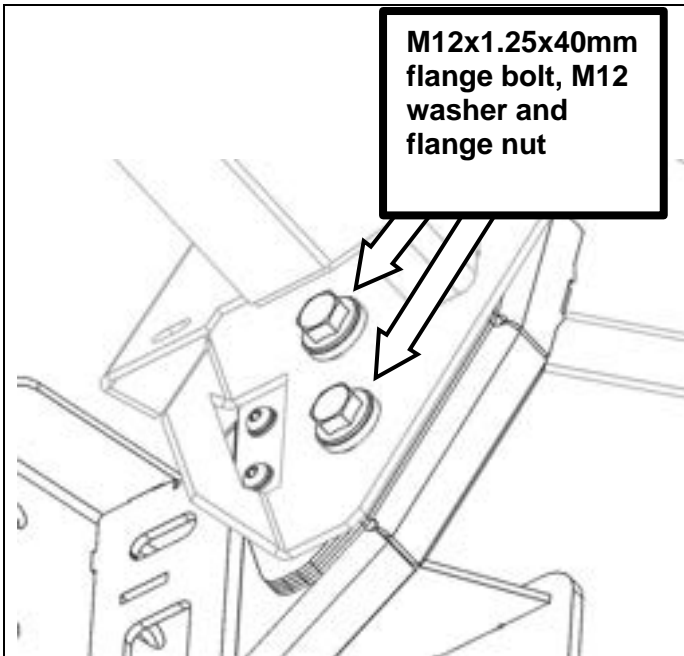

**M12x1.25x40mm
flange bolt, M12
washer and
flange nut**

42. Install two M12x1.25x40mm flange bolts, M12 washers & M12 flange nuts per side. Leave fasteners loose.

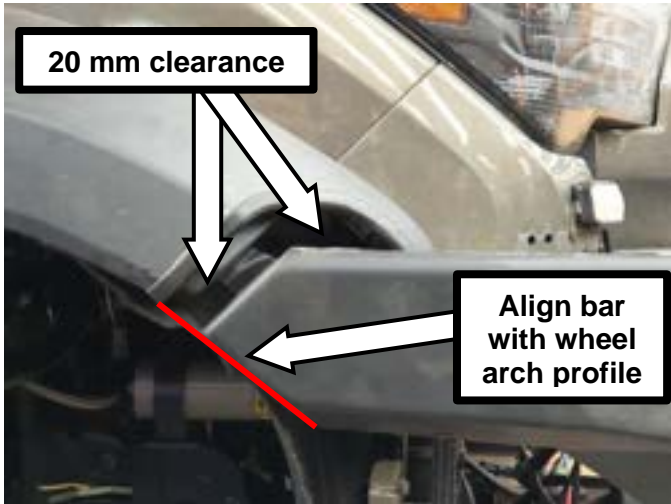

20 mm clearance

**Align bar
with wheel
arch profile**

43. Adjust the bar to make the back edge of the bar run in line with the fender/bumper join and run parallel to the cut faces with a consistent gap of 20mm.

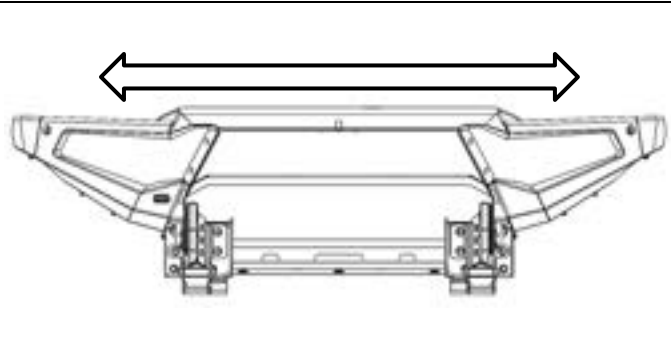

44. Ensure bar is centred on vehicle checking gap to fender on each side. Return to Step 38 if bar is not centred, and compensate accordingly with shim quantities on each side.

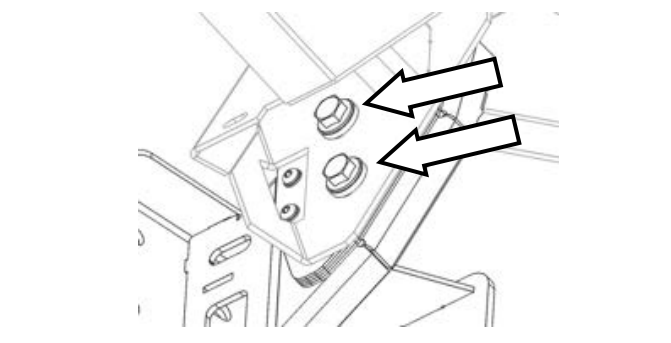

45. Torque mount fasteners to spec.

 **M12 - 102 Nm**

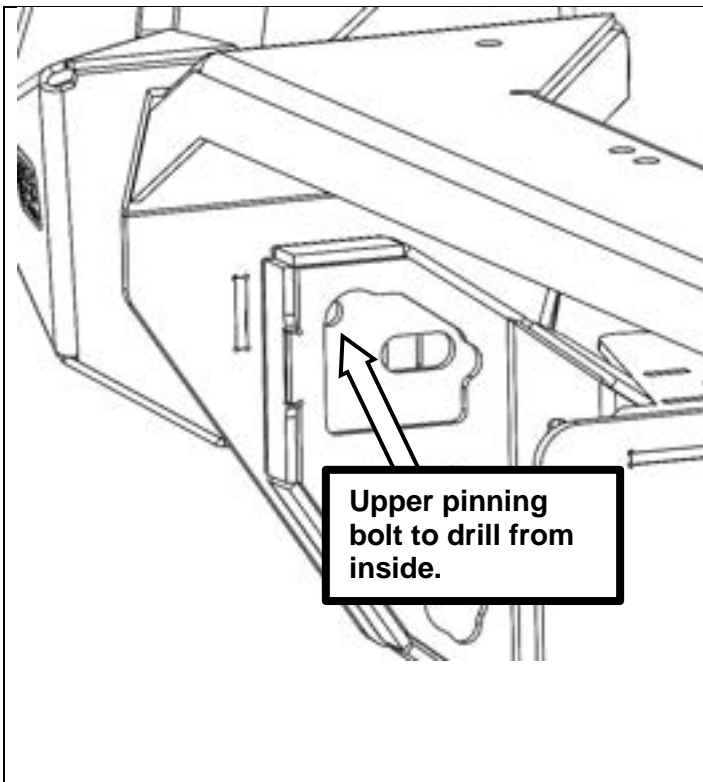

46. Drill $\text{\O}10\text{mm}$ pinning bolt holes through clearance holes provided. The lower pinning hole is drilled from the outside while the upper pinning hole is drilled from the inside.

Lower pinning bolt to drill from outside.

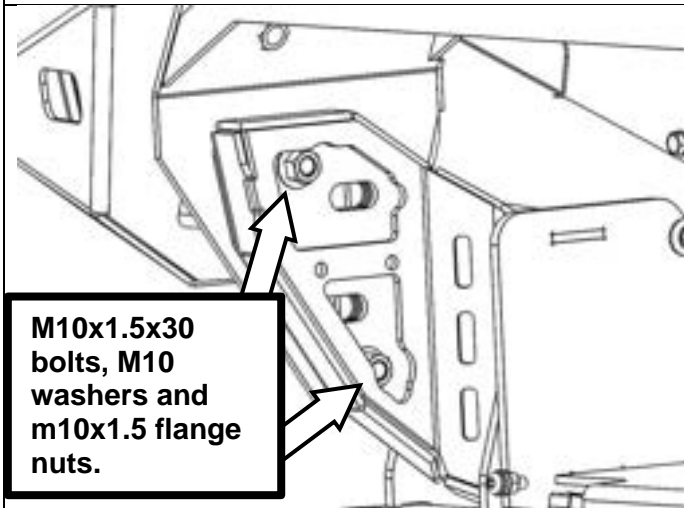
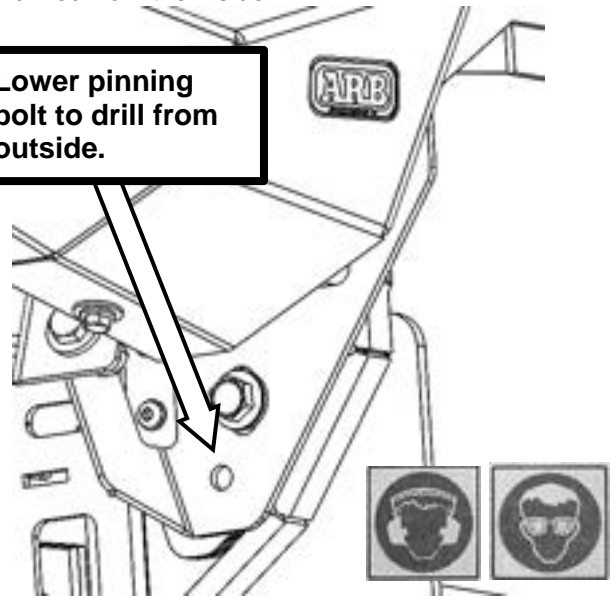

47. Install four M10x1.5x30mm flange bolts, two M10 washers and two M10x1.5 flange nuts as pinning bolts for the bar. Torque to spec.

 M10 - 44 Nm

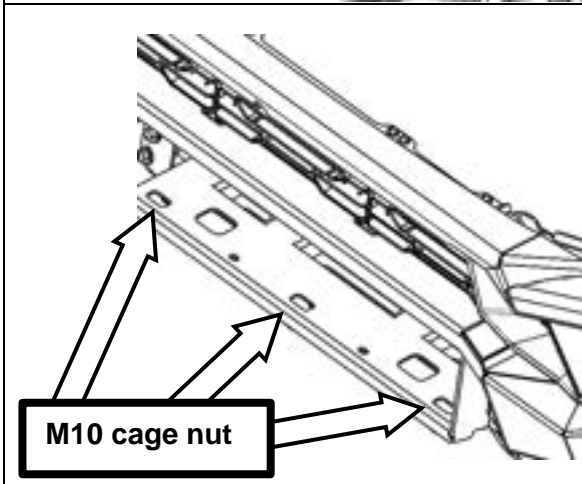

48. Install three M10 cage nuts in winch cradle for bash plate fitment where shown.

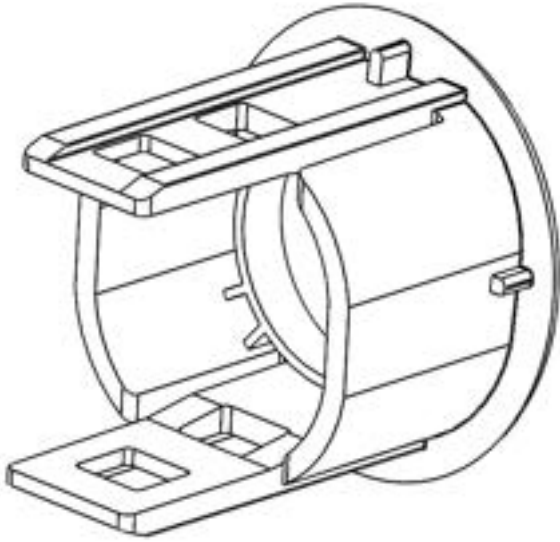

49. Fit two sensors surrounds (part number 3525010) to the bar.
50. Clip sensors into surrounds and fit extension harnesses (part number 6821451) to each sensor.
51. Plug extended sensor wires into OEM vehicle loom.

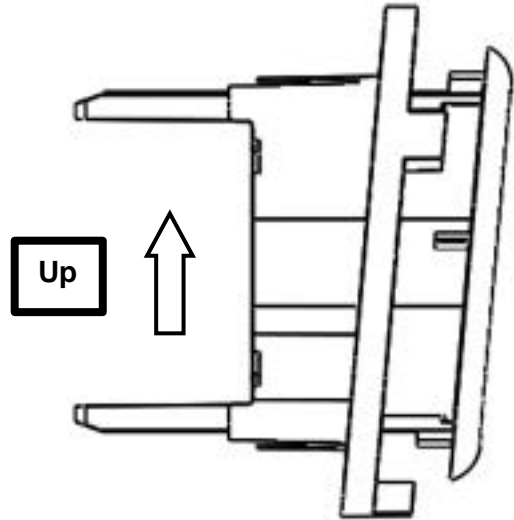

52. If fitting winch or driving lights, continue from here for respective winch and light installation instructions. **If not fitting these accessories, skip to step 64.**

Recommended grille and accessory layouts shown below:

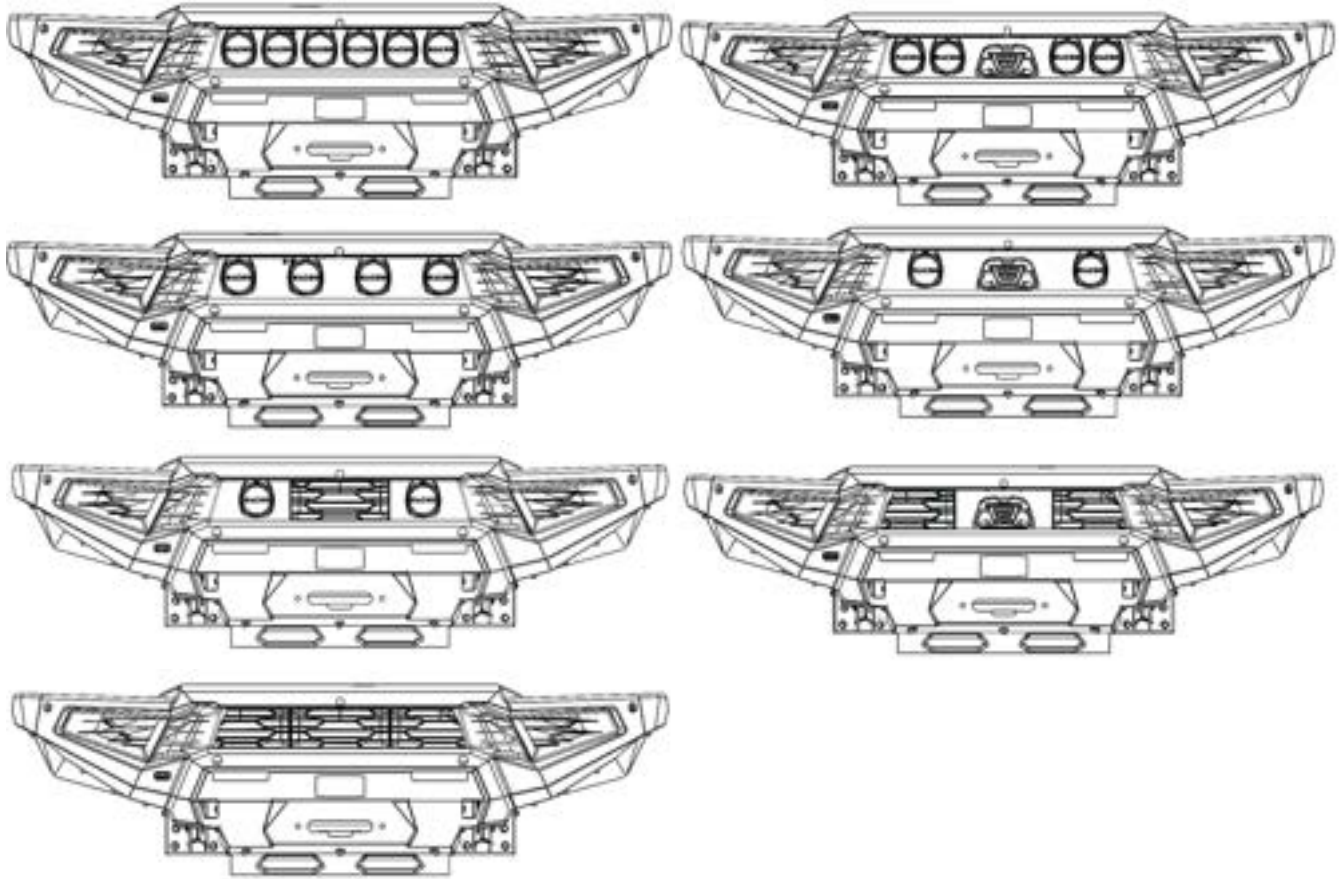

53. Fit driving lights, if doing so.

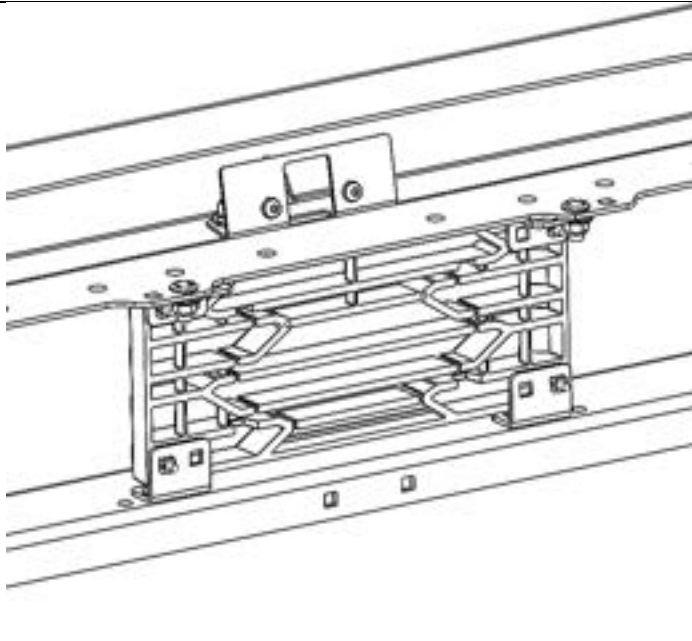

Centre Grille Only

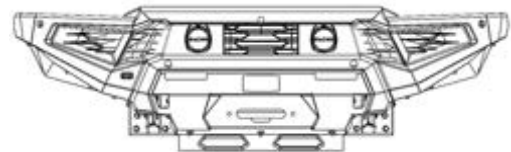

54. When fitting accessory layouts with the centre grille only, mount brackets as shown (offset inwards) using four M8 coach bolts, four M8 washers and four M8 Nyloc nuts per grille to attach to the bar. Torque to spec.

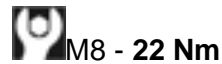

55. Fasten grille to the brackets using four screw grommets and four 20 mm black screws.

Side Grilles Only

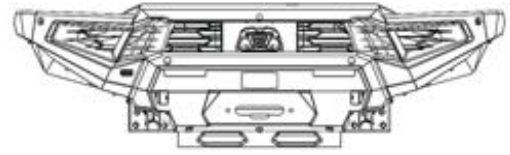

56. When fitting accessory layouts with the side grilles only, the grille can be fastened to the outer retention bracket using two 10G silver screws.

Refer to step 66 and 67 for grille cutting instructions before continuing from here.

The inner retention brackets are to be installed as shown using two screw grommets and two 20 mm black screws.

Mount grille assembly as shown using four M8 coach bolts, four M8 washers and four M8 Nyloc nuts per grille to attach to the bar. Torque to spec.



M8 - 22 Nm

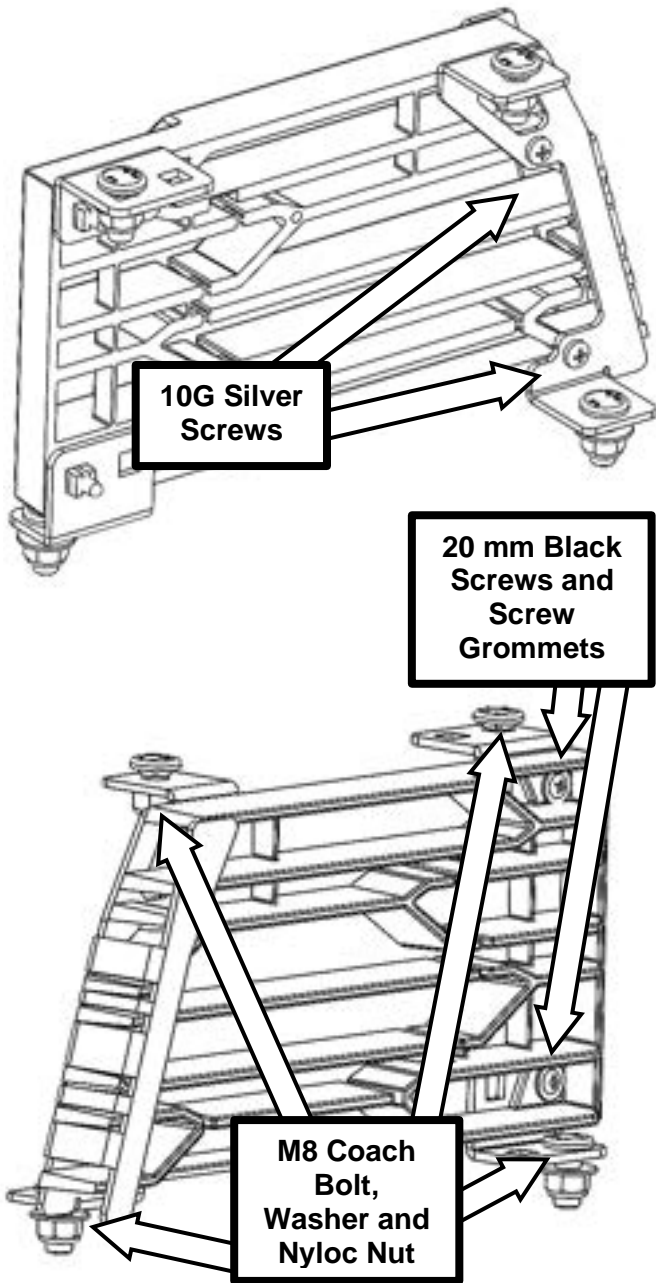

57. If not fitting a winch, skip to step 70. Otherwise, winch fitment is as follows for each supported winch (step 58 through 63):

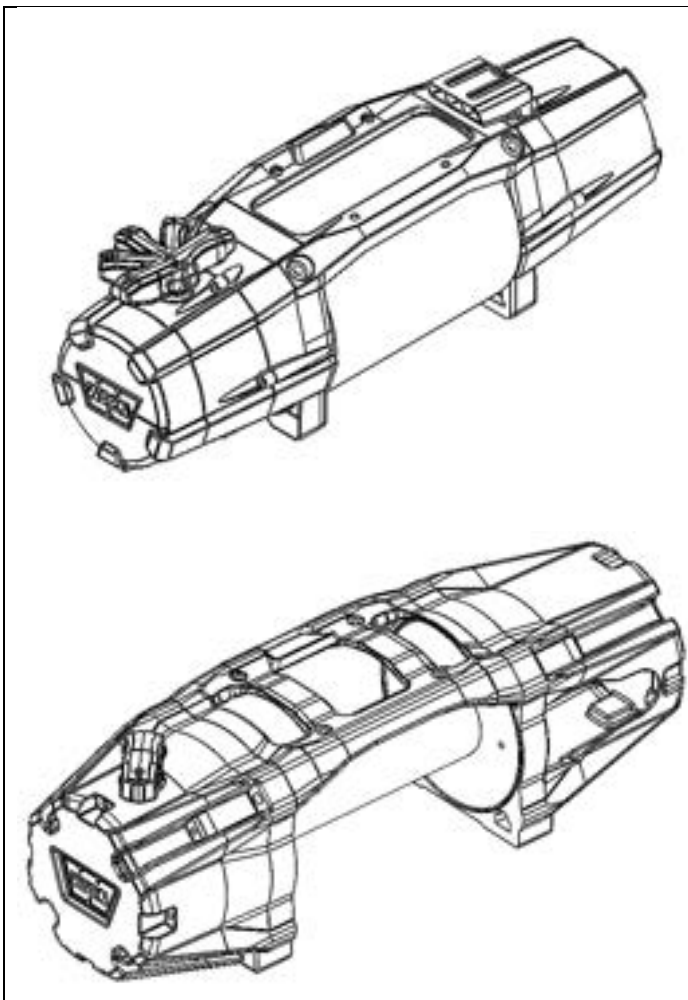

58. Warn VR EVO and Zeon variants

Remove the control box from the winch as detailed within the Warn winch instruction manual.

Fit the control box to the winch control box bracket using original hardware.

Fit the winch control box bracket with the control box fitted to the bar using two M8 coach bolts, two M8 washers and two M8 Nyloc nuts. Position the bracket in its highest position temporarily.

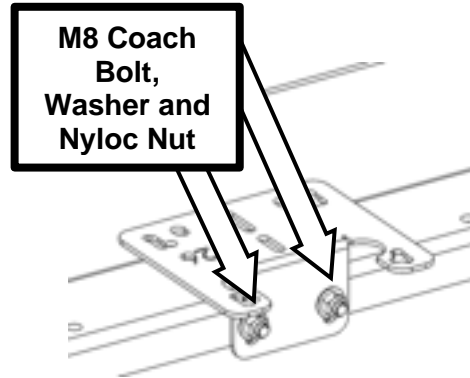

Fit the winch to the cradle and the hawse/fairlead to the bash plate. Skip to step 70.

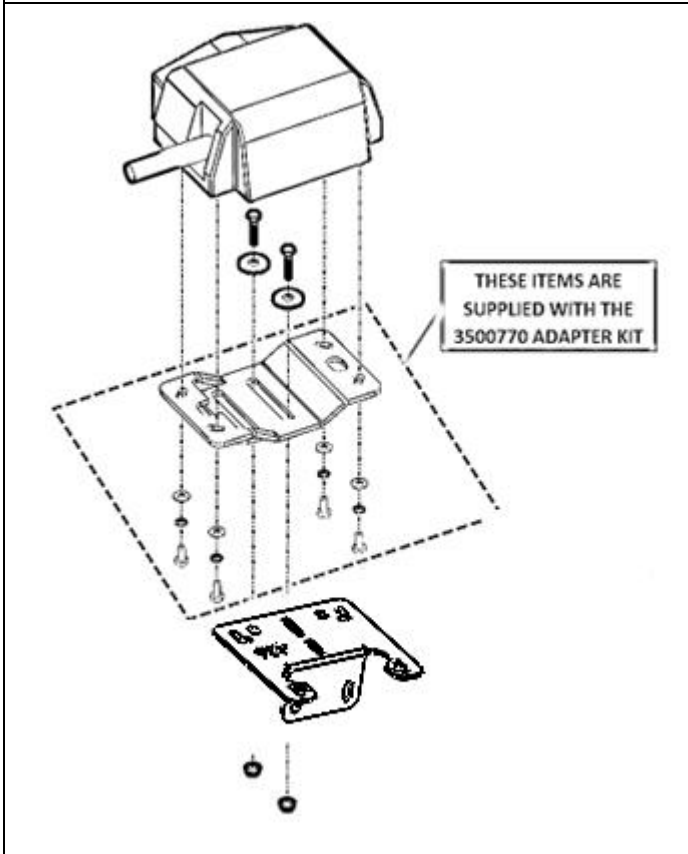

59. Warn XDC variants

Remove the control box from the winch as detailed within the Warn winch instruction manual.

Fit the control box to the winch control box bracket using optional fitting kit **3500770** as shown.

Fit the winch control box bracket with the control box fitted to the bar using two M8 coach bolts, two M8 washers and two M8 Nyloc nuts. Position the bracket in its highest position temporarily.

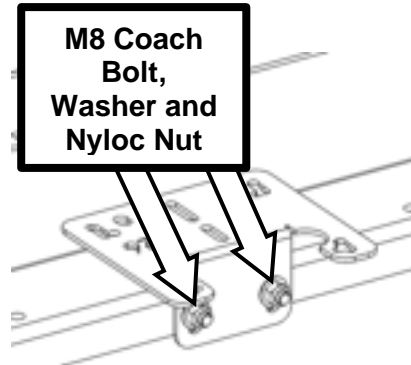

Fit the winch to the cradle and the hawse/fairlead to the bash plate. Skip to step 70.

60. Warn M8000, XD9 and 9.5XP variants are directly compatible and do not need to be clocked or disassembled for installation.

Fit the winch to the cradle with the control box mounted to the winch itself. Fit the winch to the cradle and the hawse/fairlead to the bash plate. Skip to step 70.

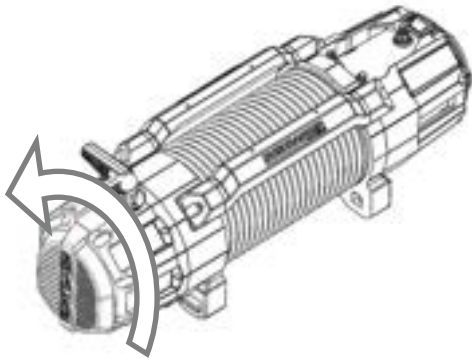

M8 Coach Bolt, Washer and Nyloc Nut

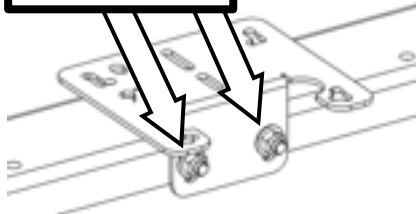

61. Bushranger Revo MkII variants

Following instructions included with the Bushranger winch, rotate the clutch assembly on the winch to position the handle on top of the winch when fitted foot down on the cradle.

Remove the control box from the winch as detailed within the Bushranger winch instruction manual.

Fit the control box to the winch control box bracket using original hardware.

Fit the winch control box bracket with the control box fitted to the bar using two M8 coach bolts, two M8 washers and two M8 Nyloc nuts. Position the bracket in its highest position temporarily.

Fit the winch to the cradle and the hawse/fairlead to the bash plate. Skip to step 70.

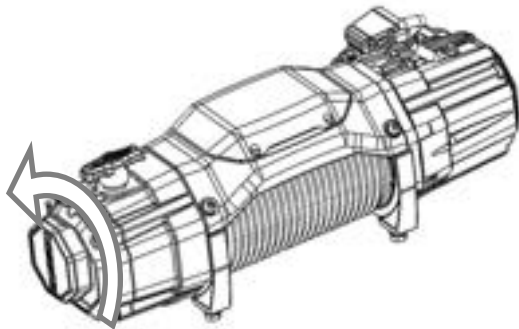

62. Bushranger Covert variants

Following instructions included with the Bushranger winch, rotate the clutch assembly on the winch to position the handle on top of the winch when fitted foot down on the cradle.

Fit the winch to the cradle and the hawse/fairlead to the bash plate. Skip to step 70.

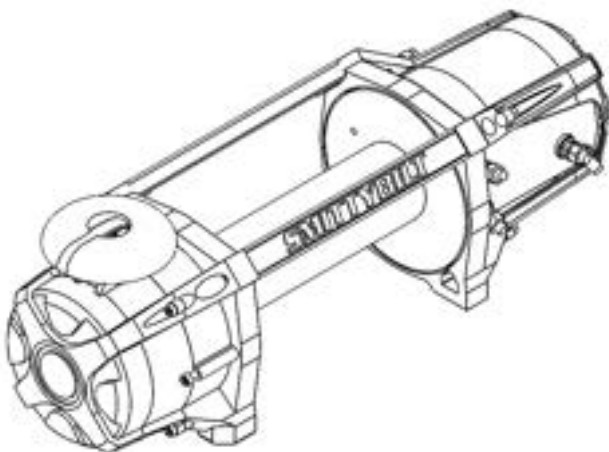

63. Smittybilt X20 variants

Remove the control box from the winch as detailed within the Smittybilt winch instruction manual.

Fit the control box to the winch control box bracket using original hardware.

Fit the winch control box bracket with the control box fitted to the bar using two M8 coach bolts, two M8 washers and two M8 Nyloc nuts. Position the bracket in its highest position temporarily.

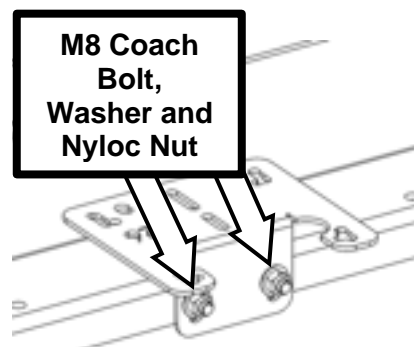

Fit the winch to the cradle and the hawse/fairlead to the bash plate. Skip to step 70.

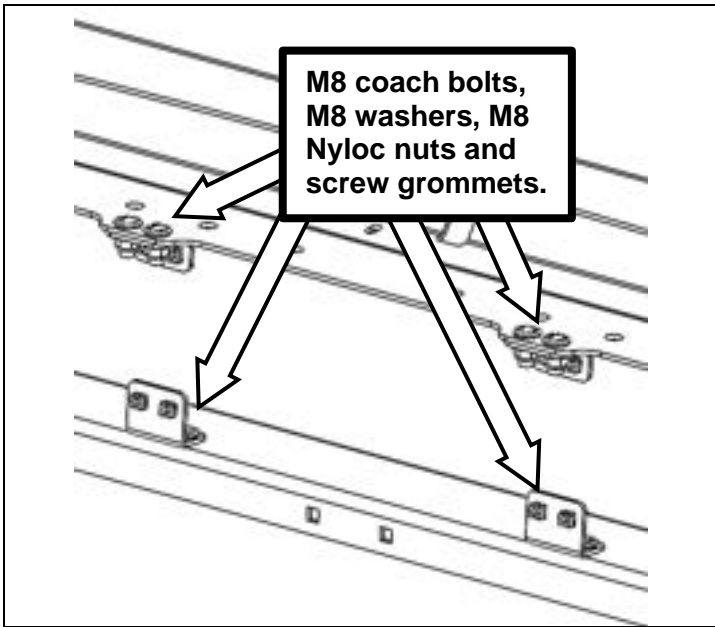

64. Install four grille retention brackets using two M8 coach bolts, two M8 washers and two M8 Nyloc nuts **per bracket**, orientation as shown. Torque to spec.

 M8 - 22 Nm

65. Press two screw grommets into each bracket, eight total.

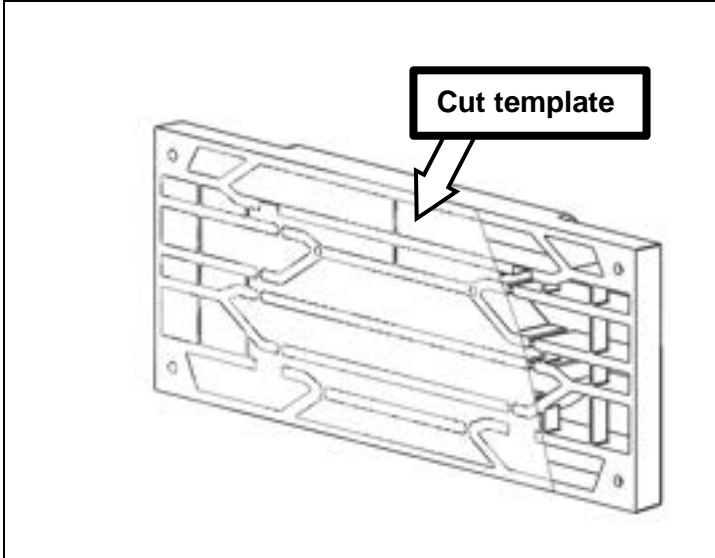

66. Cut out and apply grille template to rear face of grille, aligning the grille pattern printed on the template. Mark the cut line on the back side of the grille.

Flip template and repeat for LHS.

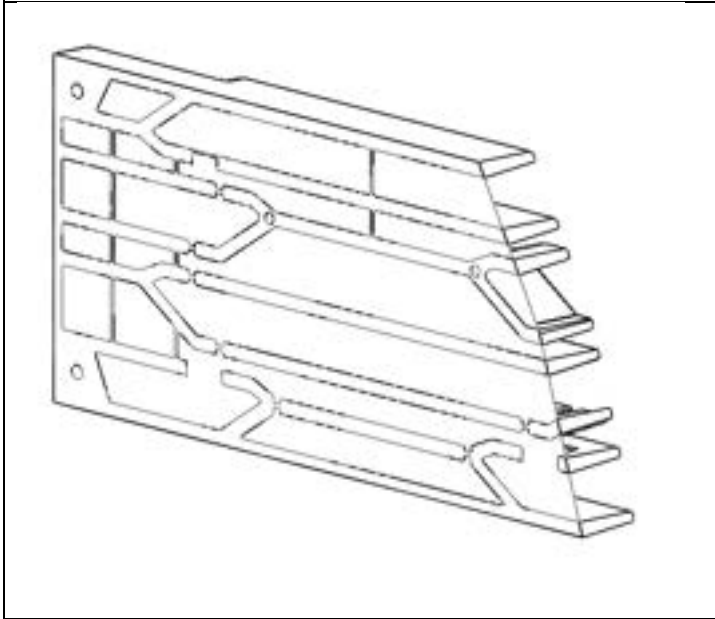

67. Cut along the marked line and debur grille.

Cut from rear with an oscillating multi-tool.



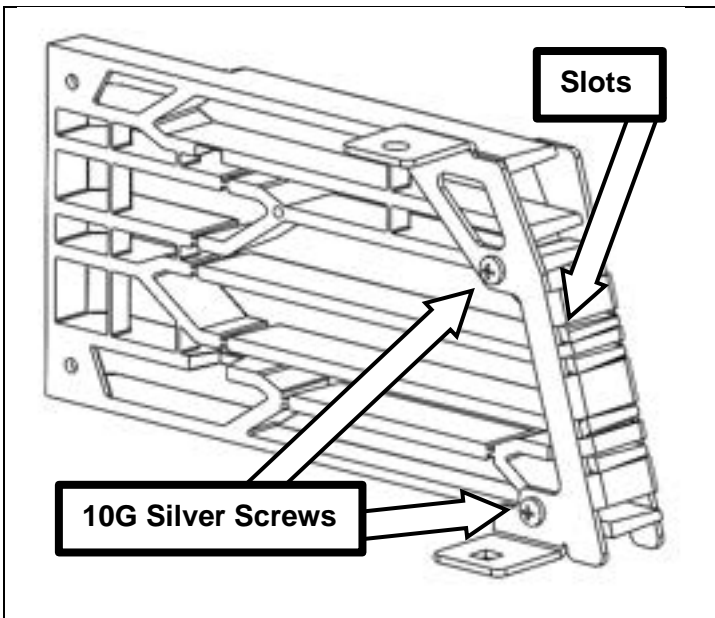

68. Fit outer grille bracket using two 10G silver screws, sliding grille into respective slots on bracket.

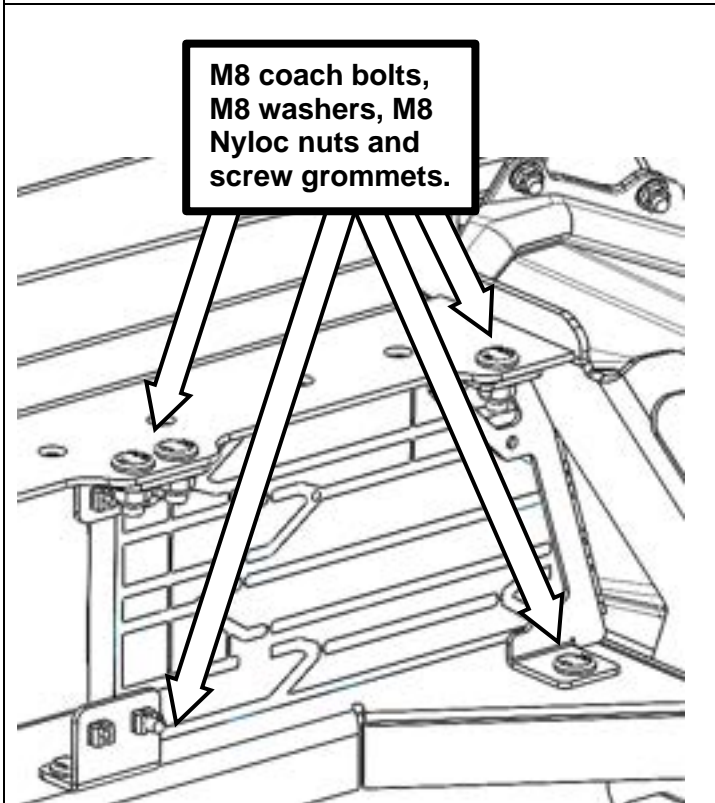

69. Fit grille to bar using two M8 coach bolts, two M8 Nyloc nuts, two M8 washers and two 20 mm black screws. Torque to spec.
Repeat for other side.

 M8 - 22 Nm

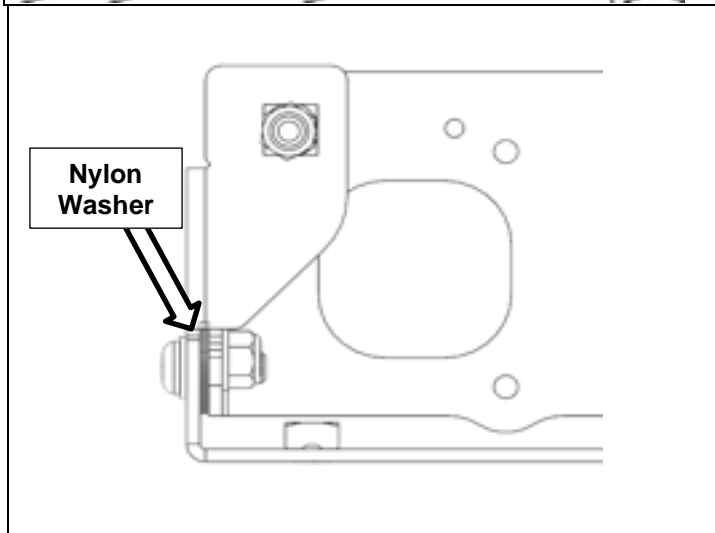

70. Assemble upper and lower half of radar bracket using two M6 button head screws, four M6 flat washers, two M6 nylon washers and two M6 nyloc nuts. Tighten to remove any play, while still allowing the bracket to pivot freely.

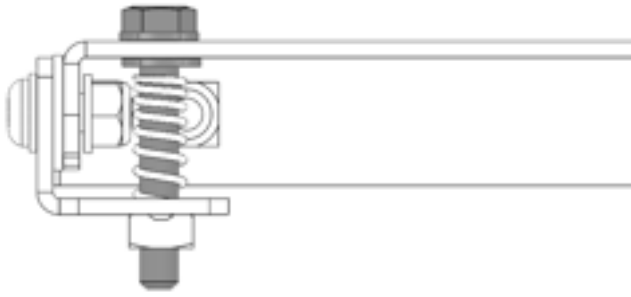

71. Assemble two M6x40 hex head bolts, two M6 flat washer and two springs provided. Position is not important at this stage.

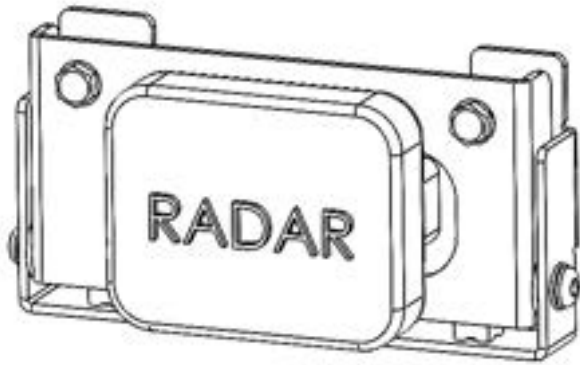

72. Fasten radar module to the bracket using 3 OEM phillips head screws.

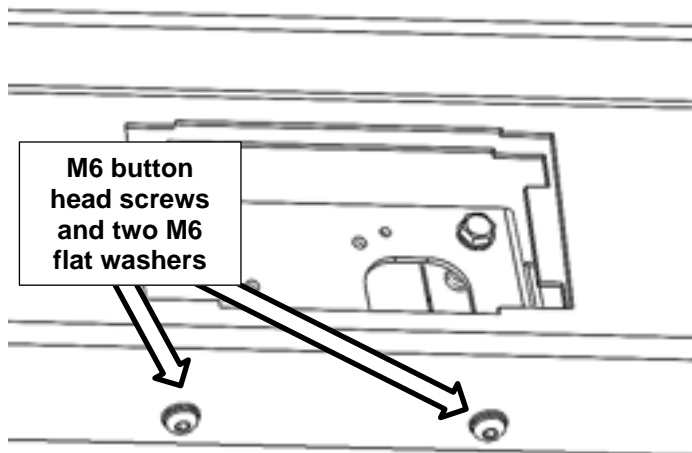

73. Fasten radar assembly to the bash plate using two M6 button head screws and two M6 flat washers. Torque to spec.



M6 - 9 Nm.

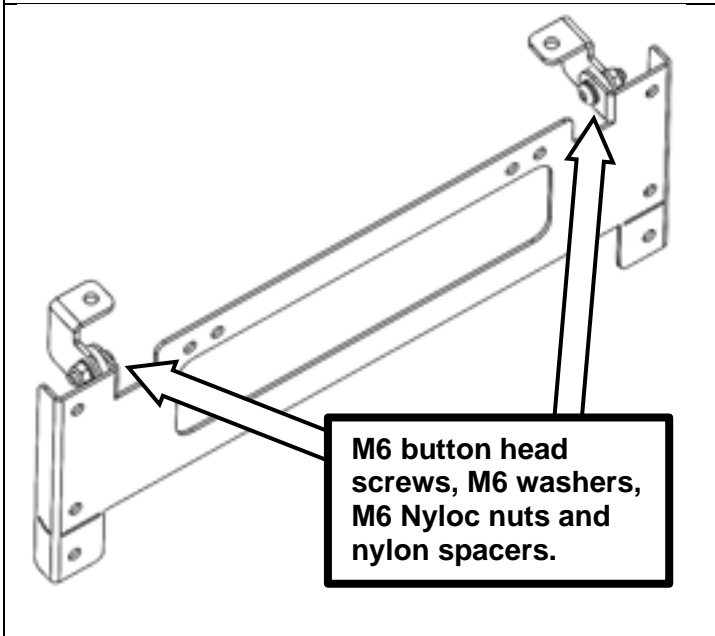
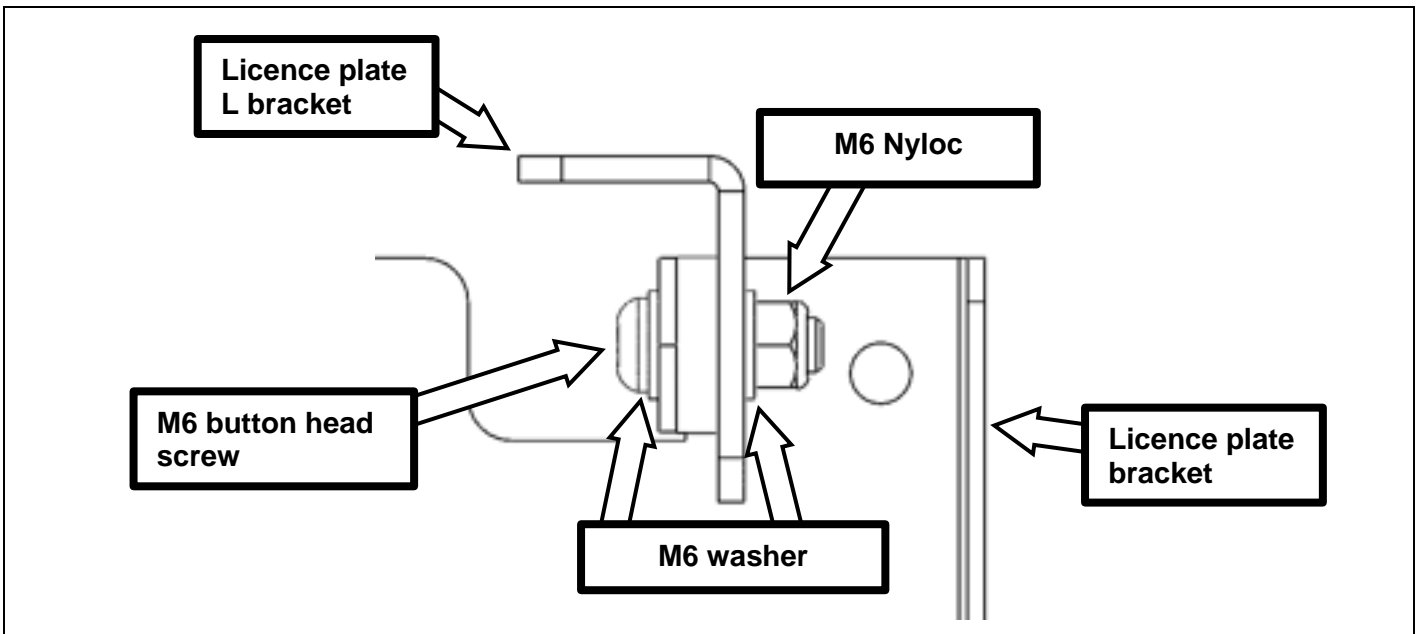

75. Assemble flip up licence plate bracket using two M6 button head screws, two M6 Nyloc nuts, two nylon spacers and four M6 washers. Tighten until firm, but can still rotate.
76. Fit licence plate bracket to bash plate, using two M6 button head screws, two M6 washers and two M6 flange nuts. Torque to spec.

 M6 - 9 Nm

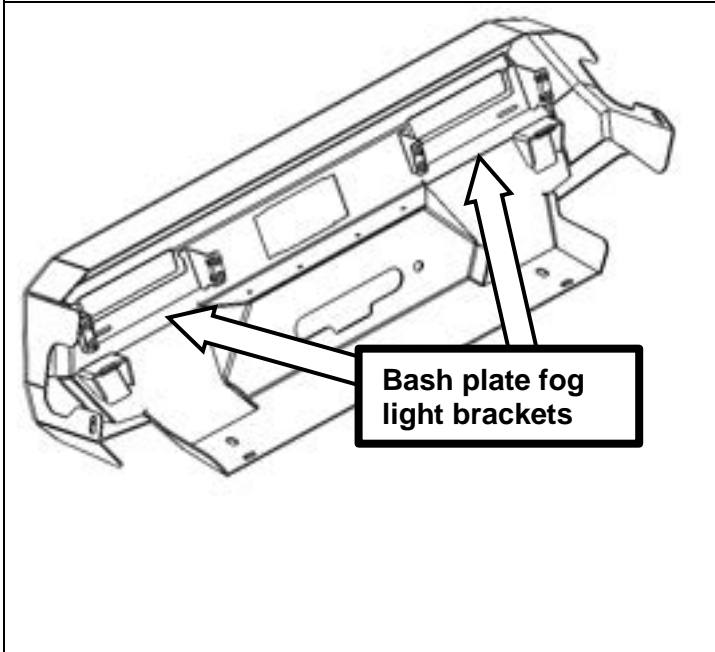

77. Fit eight screw grommets into bash plate fog light brackets.





78. Fit fog lights removed in step 16 to bash plate using eight 10G silver screws. Light units are marked LHS and RHS. Adjust to ensure light is centred in aperture before tightening.



79. Place the dressed bash plate on the vehicle.
- Note: Be careful not to scratch the powder coat on the bar or bash plate in the areas shown.**
80. Plug in radar, parking sensors and fog lights.

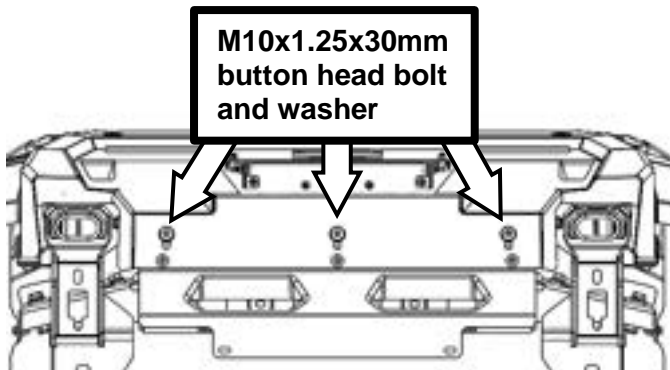

81. Fit three M10x1.5x30 button head screws, three M10 washers and three 10 mm packers (single hole) to secure the bottom of the bash plate to the winch cradle. Leave fasteners loose.

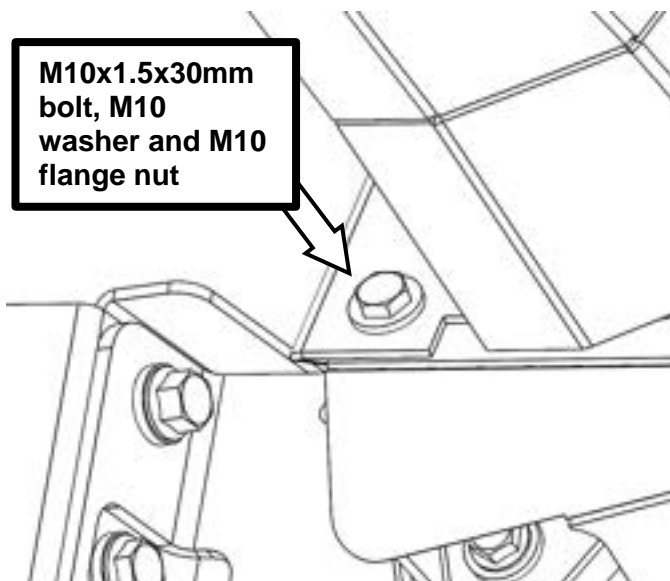

82. Fit two M10x1.5x20 bolts, two M10 washers and two M10 flange nuts to secure bash plate. Leave fasteners loose.

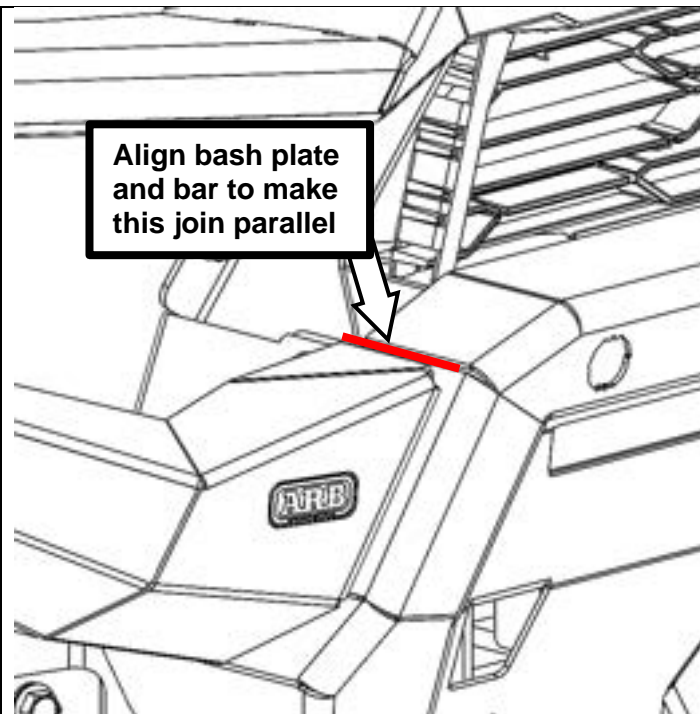

83. Align bash plate to bar, specifically with where it interfaces with the wings of the bar. The edge of the bash plate lines up parallel with the adjacent edge of the bar. Torque bash plate fasteners (five fitted) to spec.

 M10 - 44 Nm

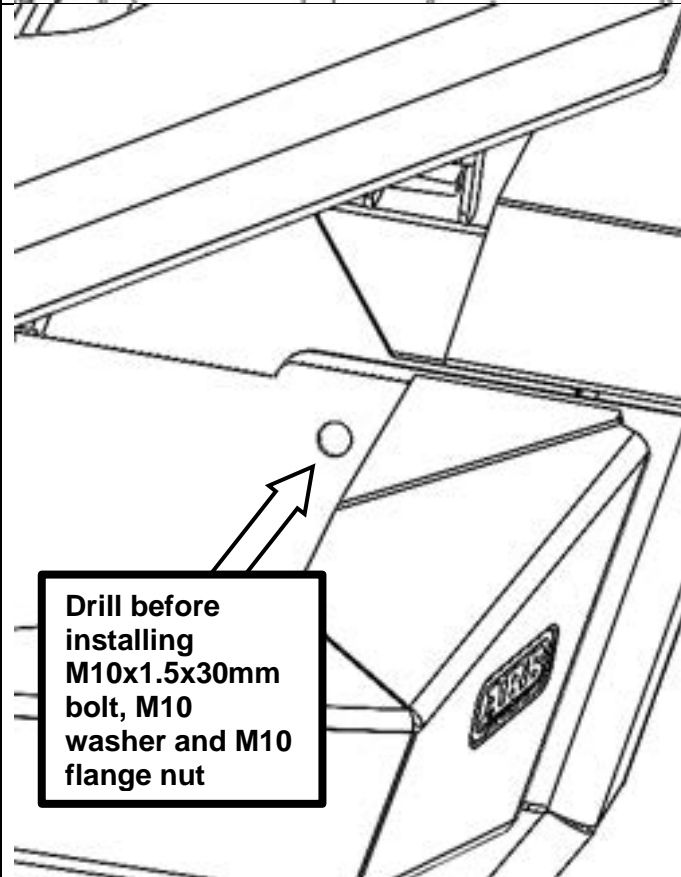

84. With the bash plate aligned with the bar, drill bash plate pinning holes through grille aperture, Ø10mm, one per side.



85. Fit two M10x1.5x30 bolts, two M10 washer and two M10 flange nuts as pinning bolts for the bash plate. Torque to spec.

 M10 - 44 Nm

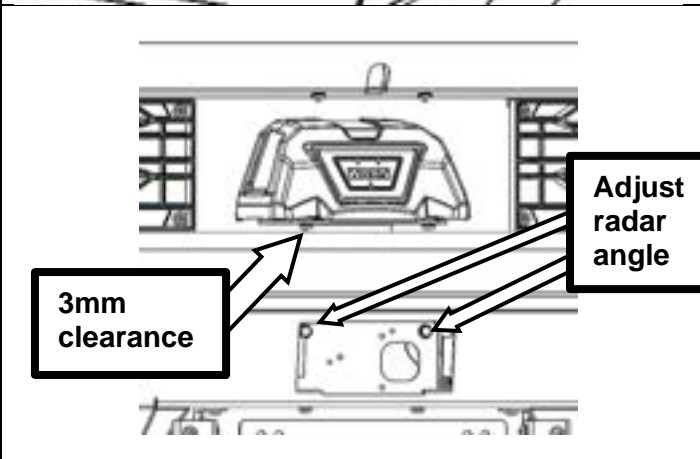

86. Place a digital level on the front face of the radar. The front face should be 90 degrees to level ground with a tolerance of ± 1 degree. Turn the two adjustment bolts evenly to alter the angle of the radar module to fall within this tolerance.

87. If fitted, move winch control box bracket down, allowing 3mm clearance from the control box fasteners to the bash plate. Torque M8 bracket bolts to spec.

 M8 - 22 Nm

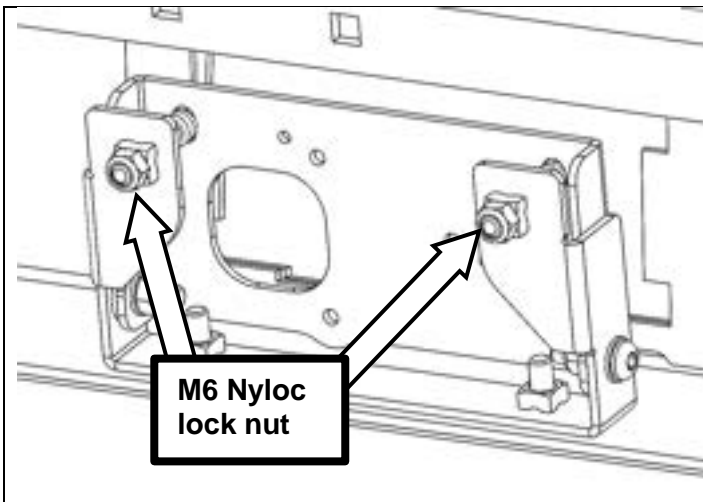

88. Lock the radar adjustment in position with two M6 Nyloc nuts tightened against the radar bracket as shown. Hold adjustment bolts in place when tightening. Torque to spec.

 M6 - 9 Nm



89. Remove OEM plastic radar cover from OEM bumper and clip into aperture in bash plate. Make sure clips fully engage and cover is in the same orientation as fitted to the OEM bumper for a secure fit ("DO NOT PAINT" text right way up).

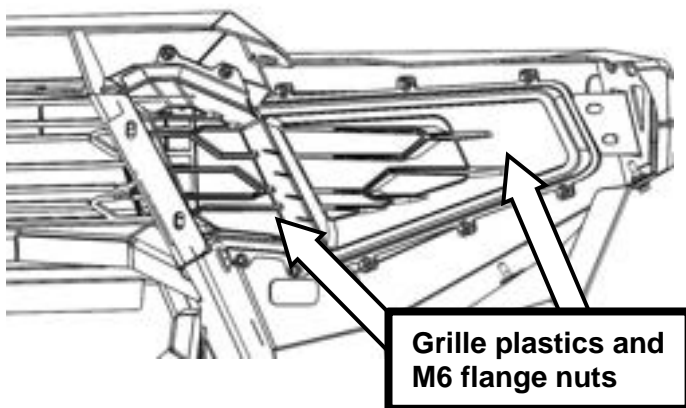

90. Fit grille plastics to bar using twenty M6 flange nuts. Torque to spec.

 M6 - 9 Nm

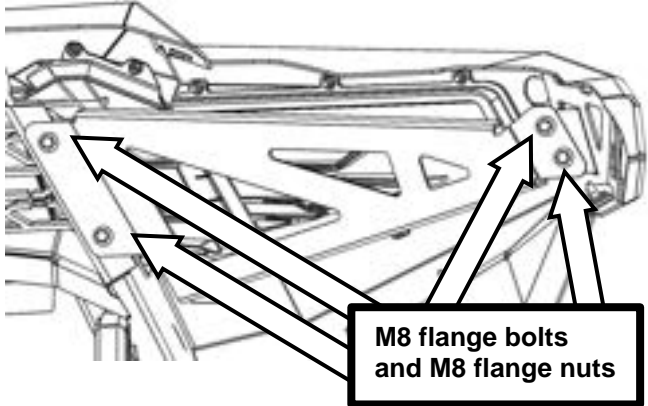

91. Fit wing braces to bar using eight M8 flange bolts and eight M8 flange nuts. Torque to spec.

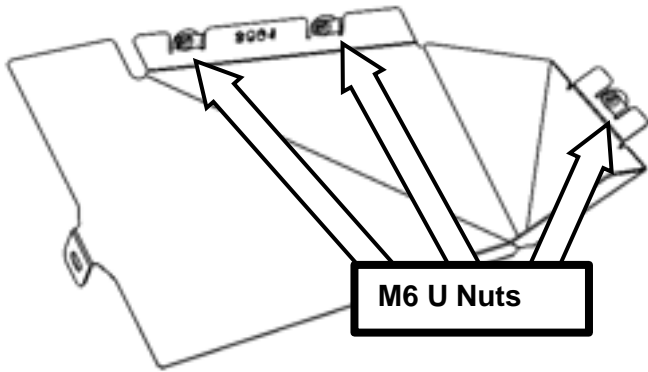
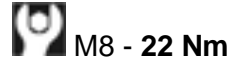

92. Fit M6 U nuts to both under panels as shown, six total.



93. Place the RH under panel in position while tucking the wheel liner in place.

Repeat for other side.



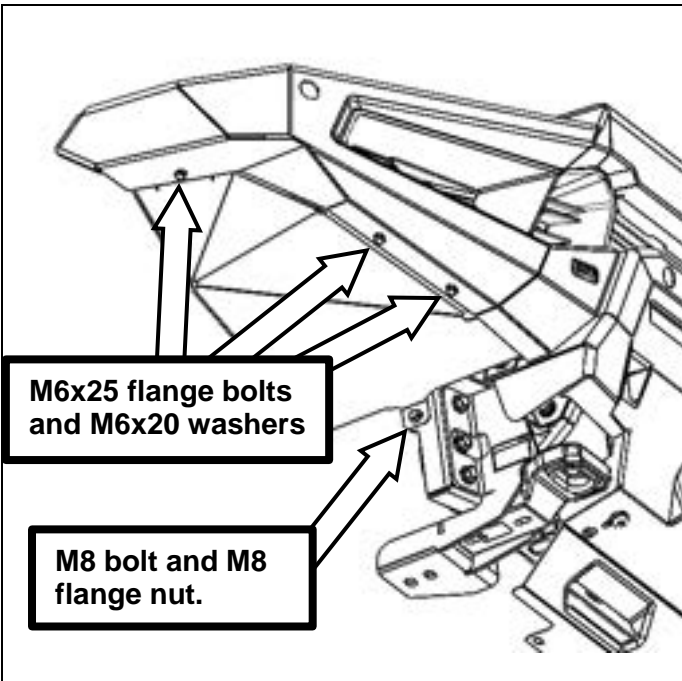

94. Secure the RH wing under panel using three M6 flange bolts, three M6x20 washers, an M8 bolt and an M8 flange nut. Torque to spec.

Repeat for other side.

 M6 - 9 Nm

 M8 - 22 Nm

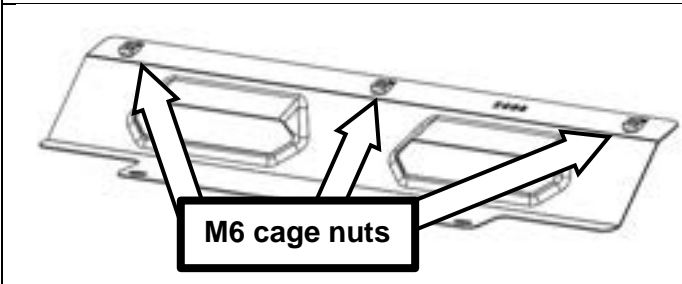

95. Fit three M6 cage nuts to stone tray.



96. Remove front two bolts from OEM underpanel. Fit Zenith stone tray on top, securing with same OEM M8 bolts. Secure with further three M6 button head screws and three M6 washers through the bash plate. Torque to spec.

 M6 - 9 Nm

 M8 - 22 Nm

Silver M6 button head screws and silver M6 washers.

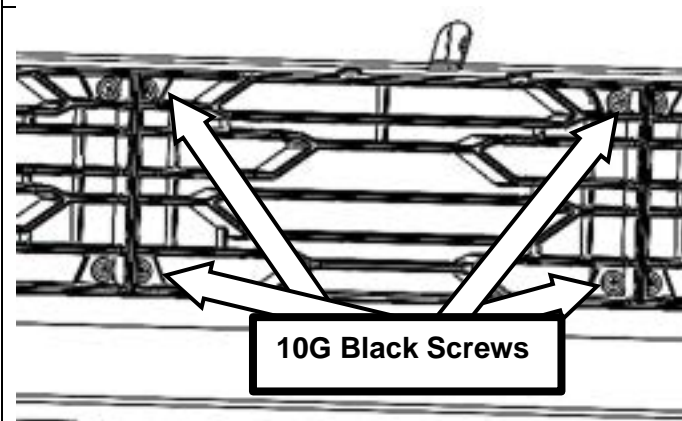
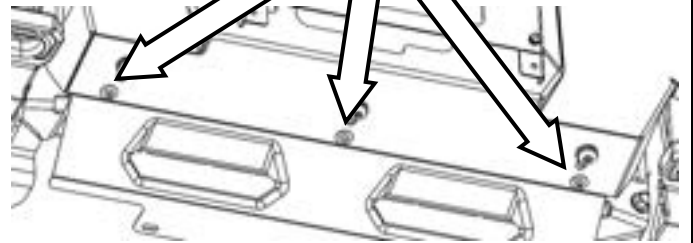

97. Attach centre grille, if not yet fitted, using four 10G black screws.

FITTED PRODUCT

NOTICE: ONCE ZENITH BAR IS FITTED:

- ◆ Ensure all bolts are tensioned correctly.
- ◆ All wiring is clear of sharp edges or moving surfaces and secured properly.
- ◆ Piping is secured well away from sharp or moving components.
- ◆ Check operation of winch, if fitted.
- ◆ Check all wiring and connections to sensors, camera and radar are functioning correctly.
- ◆ Misalignment of parking sensor to hole in bull bar may cause malfunction, if fitted.
- ◆ If fitted, test operation of parking sensors after fitment.

