



FITTING INSTRUCTIONS

Part Number: **3414570**
Product **F/INST HILUX SUMMIT BULLBAR 150N**
Description:
Suited to **2015 TOYOTA HILUX NARROW BODY**
vehicle/s:
Optional **3500530 - ARB AUX Fog Light Loom**
Fitting Kits: **3500680 - Fog Lamp Housing Clear Lens Kit**
3500590 - Fog Light Kit (LH&RH Lights)
3500720 - SUMMIT BAR WINCH INSTALL KIT

WARNING

REGARDING VEHICLES EQUIPPED WITH SRS AIRBAG:

When installed in accordance with these instructions, the front protection bar does not affect operation of the SRS airbag.

ALSO, NOTE THE FOLLOWING:

- ◆ This product must be installed exactly as per these instructions using only the hardware supplied.
- ◆ In the event of damage to any bull bar component, contact your nearest authorised ARB stockist. Repairs or modifications to the impact absorption system must not be attempted.
- ◆ Do not use this product for any vehicle make or model, other than those specified by ARB.
- ◆ Do not remove labels from this bull bar.
- ◆ This product or its fixing must not be modified in any way.
- ◆ The installation of this product may require the use of specialized tools and/or techniques
- ◆ It is recommended that this product is only installed by trained personnel
- ◆ These instructions are correct as at the publication date. ARB Corporation Ltd. cannot be held responsible for the impact of any changes subsequently made by the vehicle manufacturer
- ◆ During installation, it is the duty of the installer to check correct operation/clearances of all components
- ◆ Work safely at all times
- ◆ Unless otherwise instructed, tighten fasteners to specified torque

ARB 4x4 ACCESSORIES

Corporate Head Office

42-44 Garden St
Kilsyth, Victoria 3137
AUSTRALIA

Tel: +61 (3) 9761 6622
Fax: +61 (3) 9761 6807

Australian enquiries
North & South American enquiries
Other international enquiries

sales@arb.com.au
sales@arbusa.com
exports@arb.com.au

www.arb.com.au

GENERAL CARE AND MAINTENANCE

By choosing an ARB Bar, you have bought a product that is one of the most sought after 4WD products in the world. Your bar is a properly engineered, reliable, quality accessory that represents excellent value. To keep your bar in original condition it is important to care and maintain it following these recommendations:



- Prior to exposure to the weather your bar should be treated to a Carnauba based polish on all exposed surfaces. It is recommended that this is performed on a six monthly basis or following exposure to salt, mud, sand or other contaminants.
- As part of any Pre Trip Preparation, or on an annual basis, it is recommended that a thorough visual inspection of the bar is carried out, making sure that all bolts and other components are torqued to the correct specification. Also check that all wiring sheaths, connectors, and fittings are free of damage. Replace any components as necessary. This service can be performed by your local authorized ARB Stockist.

FITTING REQUIREMENTS

REQUIRED TOOLS FOR FITMENT OF PRODUCT:

BASIC TOOL KIT	ELECTRIC DRILL WITH COMPLETE METRIC DRILL SET
MULTITOOL OR JIG SAW WITH BLADE SUITABLE FOR PLASTIC	LOW TACK MASKING TAPE
FILE	UTILITY KNIFE
TAPE MEASURE	CLAMP
STEEL RULER	WHITE FELT MARKER
HACK SAW	TORQUE WRENCH 9-77Nm
TOUCH UP PAINT ANTI CORROSION	RIGHT ANGLE ELECTRIC DRILL
MATT BLACK QUICK DRY SPREY PAINT	

HAVE AVAILABLE THESE SAFETY ITEMS WHEN FITTING PRODUCT:

Protective eyewear 	Hearing protection 
--	--

NOTE: 'WARNING' notes in the fitting procedure relate to OHS situations, where to avoid a potentially hazardous situation it is suggested that protective safety gear be worn or a safe work procedure be employed. If these notes and warnings are not heeded, injury may result.

FASTENER TORQUE SETTINGS:

SIZE	Torque Nm	Torque lbft
M6	9Nm	7lbft
M8	22Nm	16lbft
M10	44Nm	32lbft
M12	77Nm	57lbft

PARTS LISTING

APPLICATION.	PART NO.	QTY	DESCRIPTION
--------------	----------	-----	-------------

FIT MOUNTS TO CHASSIS	3759738R	1	BRKT MNT STEEL HILUX 15ON RHS
	3759738L	1	BRKT MNT STEEL HILUX 15ON LHS
	3759667R	1	BRKT CHASSIS OUT HILUX 15ON RH
	3759667L	1	BRKT CHASSIS OUT HILUX 15ON LH
	3759666R	1	BRKT CHASSIS IN HILUX 15ON RHS
	3759666L	1	BRKT CHASSIS IN HILUX 15ON LHS
	6151094	2	BOLT M12 x 1.25 x 30 Gd8.8 ZP
	6151428	4	NUT FLANGE M12 X 1.75 ZP
	4581007	14	WASHER FLAT ½ x 1 1/2 x 4MM SILVER TZP
	4581050	14	WASHER SPRING ½ x 3/16 x 1/8 ZP
	6151357	8	BOLT SEMS M10 X 30 ZP Gd8.8
	6151321	8	NUT FLANGE M10 x 1.5 ZP
	4581040	4	WASHER FLAT M10 X 25 X 3 ZP
	3194818	4	PLATE NUT ASSY HILUX BAR 15ON
	6151360	12	BOLT M12 x 1.75 x 35 Gd 8.8 ZP
FIT BAR TO MOUNTS	3414570	1	SUMMIT COMBAR HILUX 15ON FLARED AF20 8-10
	6151360	6	BOLT M12 x 1.75 x 35 Gd 8.8 ZP
	6151357	4	BOLT SEMS M10 X 30 ZP Gd 8.8
	4581050	6	WASHER SPRING ½ x 3/16 x 1/8 ZP
	4581007	6	WASHER FLAT ½ x 1 1/2 x 4MM SILVER TZP
	6151428	6	NUT FLANGE M12 X 1.75 ZP
	6151321	4	NUT FLANGE M10 x 1.5 ZP
FIT LIGHTS AND MOULDINGS	3500880	1	GRILLE SPLIT PAN KIT
	5100200	1	BUFF KIT 2PCE FRONT SECTION KIT
	5100210	1	BUFF KIT 2PCE REAR UPRIGHT BAR KIT
	6821287	1	LAMP LED INDICATOR CLEARANCE KIT
	3163082	1	SURROUND ARB FOGLIGHT KIT
	6821116	4	GROMMET NYLON SNAP IN TYPE
	5848428	4	SHIM OVER RIDER 1.6MM
FIT STONE GUARDS	6523042	1	PANEL STONE GUARD HILUX 15ON
	6523092R	1	PANEL WING HILUX 15ON RHS
	6523092L	1	PANEL WING HILUX 15ON LHS
	6151300	8	NUT CAGED M6 2.6-3.5
	6151234	6	BOLT M8 x 1.25 x 25 Gd 8.8 BP
	4581287	10	WASHER SPRING M6 x 2.5 x 1.6 BLK ZN
	4581047	6	WASHER SPRING M8 x 3/32 x 3/33 BLK ZN
	4581082	10	WASHER FLAT, M6 x 19 x 1.6 BZ
	6151301	4	NUT CAGED M8
	4581307	6	WASHER FLAT, M8 x 20 x 2 BLK ZN
	6151213	10	BOLT M6x1.0x20 8.8 BZ
	6151548	2	FLANGE NUT M8X1.25 BLK ZN

PARTS LISTING - Continued

APPLICATION.	PART NO.	QTY	DESCRIPTION
FIT WINCH COVER PANEL	6523091	1	PRESS FORM WINCH COVER PANEL HILUX
	6151213	4	BOLT M6x1.0x20 8.8 BZ
	4581287	4	WASHER SPRING M6 x 2.5 x 1.6 BLK ZN
	4584295	4	WASHER FLAT M6 X 12 X 1.3 BLK ZN
	6151128	4	NUT FLANGE M6 x 1.0 ZP
FIT LICENSE PLATE	3759488	1	BRACKET REG PLATE FIXED LARGE RAD
	6151384	2	SCREW 10G x 5/8 SELF TAPPING
	6821189	2	GROMMET RND FC 1500 080 090
	6151213	3	BOLT M6x1.0x20 8.8 BZ
	4581287	3	WASHER SPRING M6 x 2.5 x 1.6 BLK ZN
	4584295	3	WASHER FLAT M6 x 12 x 1.3 BLK ZN
MISCELLANEOUS	6191025	2	PINCH WELD 480mm
	6191034	2	PINCH WELD 88mm
	3789462	1	TEMPLATE 1 NARROW HILUX 15ON
	3789446	1	TEMPLATE 2 HILUX BULLBAR 15ON
	180302	8	CABLE TIE 4.8 x 180mm BLACK

FITTING PROCEDURE



Note: Read the instructions thoroughly before starting.

1. Open the bonnet and remove all scrivets retaining grille.

Set aside scrivets removed for re-use later on.

Note: Take note where all fasteners are removed from as some have to be refitted later in the fitment.



2. Remove lower grille retaining screws – (Right hand side shown).

Note: Centre grille retaining screw shown in lower image.

Set aside for re-fitment later on.

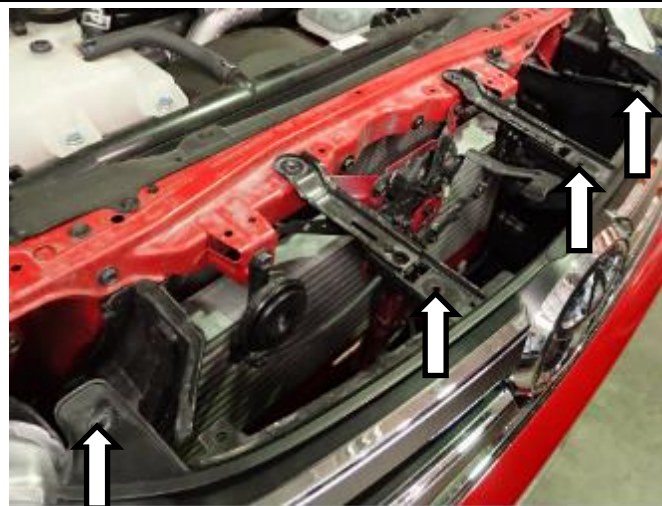
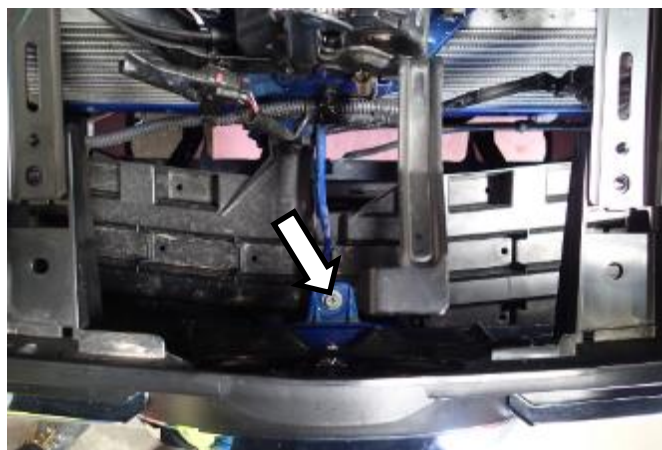

3. Remove upper grille retaining screws.

Set aside for re-fitment later on.

FITTING PROCEDURE - Continued



4. Remove all fasteners and scrivets retaining bumper along inside edge of wheel arches – (Right hand side shown).

Set aside for re-fitment later on.

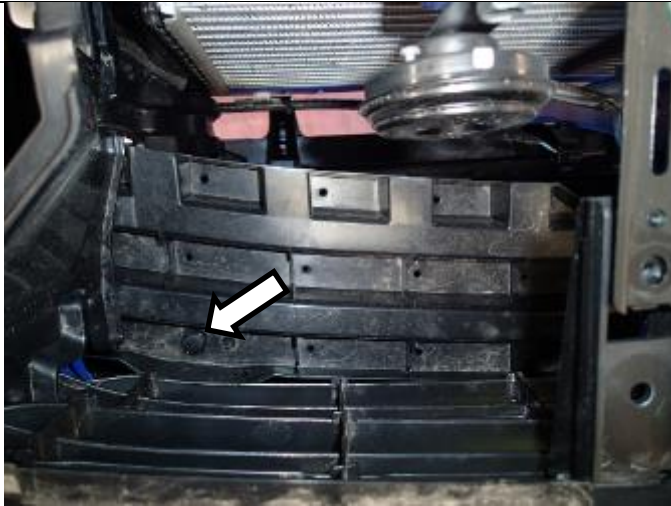

5. Remove the scrivets used to fasten the lower grille tabs to the upper crush panel. (Right hand side shown).

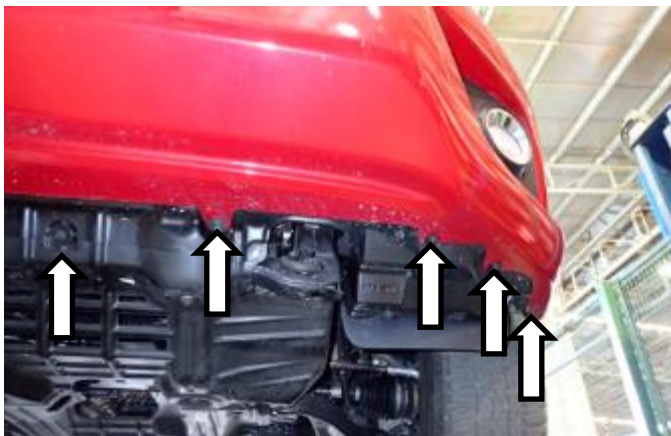

6. Remove all fasteners and scrivets retaining bumper along lower lip – (Left Hand side shown).

Set aside scrivets and fasteners used to attach bumper to OEM stone deflector for re-use later on.



7. Remove dressing piece from underside of bumper and discard.

FITTING PROCEDURE - Continued



8. Ensure inner guards are unclipped from front bumper.



9. Disconnect fog light wiring – (Right Hand side shown).



10. Remove registration plate and set aside, then carefully remove bumper from vehicle by pulling on each side of the bumper near the wheel arches and working your way towards the centre.

Set grille and bumper aside for re-use later in the fitment procedure.



11. Remove plastic lower crush absorber from vehicle and discard.

Note: Lower crush absorber is retained by plastic clips. Levering absorber free with a large screw driver may aid removal.

FITTING PROCEDURE - Continued

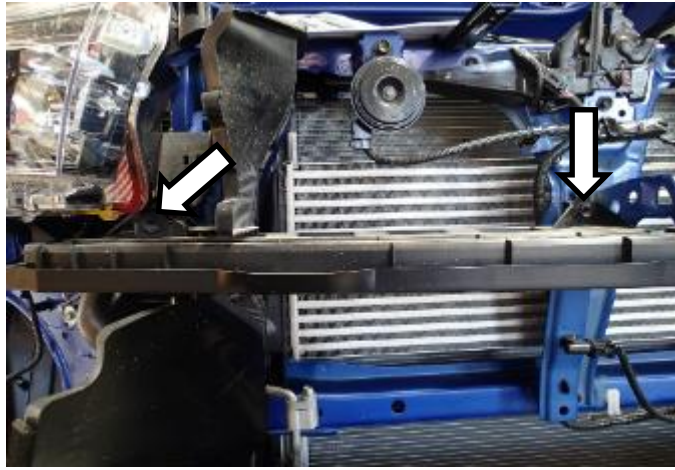

12. Remove 3 x M8 fasteners from upper crush panel. Remove crush panel from vehicle and discard.

Note: LH M8 Fastener not visible.



13. Remove M8 fastener from upper crush panel support brackets. Remove support brackets from vehicle and discard. (Right hand side shown).



14. Remove 2 x M10 bolts on both sides (4 total) fixing crash beam to chassis and remove crash beam.

Discard crash beam.

Note: Retain 4 x M10 bolts for re-use.

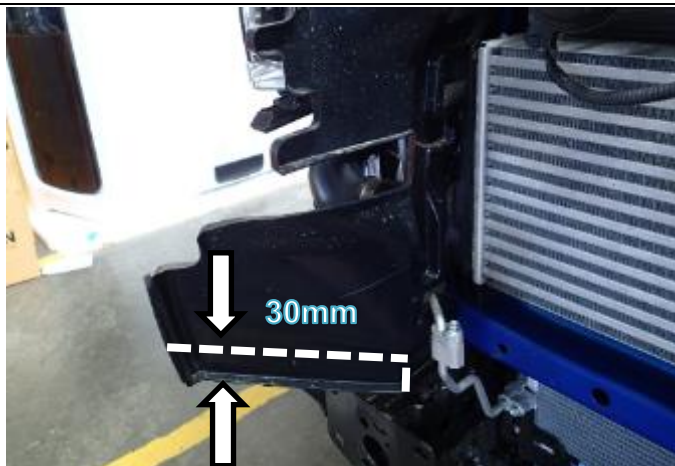

15. Locate air deflector panels and mark up 30mm from bottom edge as detailed in the image – (Right Hand side shown).

16. Use scissors or shears to carefully cut lower portion away and discard.

Note: Take care not to damage any other components on the vehicle whilst cutting.

17. Carefully remove any burrs or sharp edges with a file and/or sandpaper.

FITTING PROCEDURE - Continued

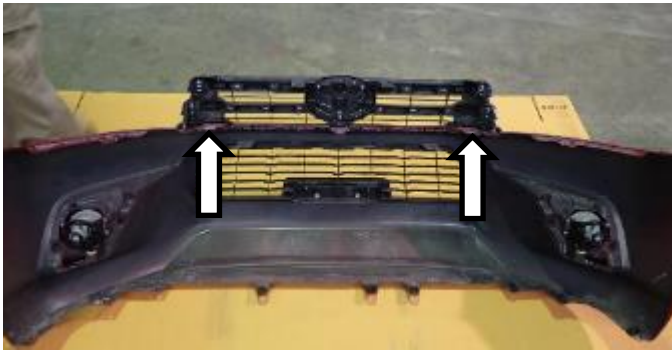

18. Remove grille from bumper by carefully releasing locking tabs whilst removing.

Set grille and bumper aside for re-use later in the fitment procedure.



19. With grille and bumper removed, remove LH and RH headlight retaining fasteners to allow headlight to be moved forward giving access to indicator/headlight wiring.

Note: Retain all fasteners for re-use later in the fitment procedure.



FITTING PROCEDURE - Continued

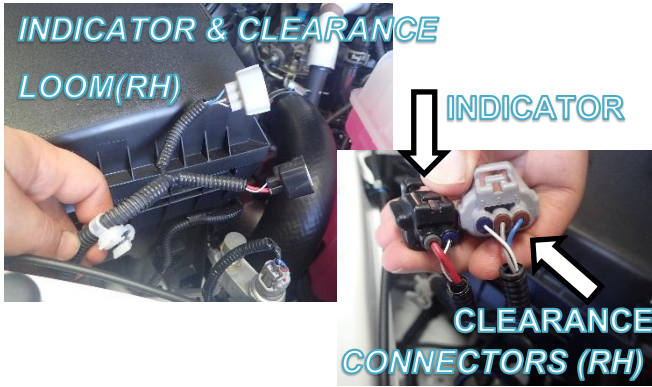

**RHS shown, all images taken from below*

Function	LED Wire	Vehicle Wire
Ground	Black	White Black (RHS & LHS)
Indicator	Green	Red (RHS) Yellow (LHS)
Clearance	Red	Grey (RHS) Green (LHS)

20. Following fitting instructions 3789197 supplied in kit 6821287; attach the LED combination lamp looms (also supplied in same kit). Vehicle coloured wires can be found in the positions indicated.

Notes:

- Use a test light or multimeter to pick the appropriate wire to attach the loom to.
- Cover each joint with either insulation tape or heat shrink tube.
- Use cable ties to secure all wiring.
- Keep all cables clear of sharp edges and moving parts.

Check the operation of all lights wired during bar fitment



21. Remove the bumper retention block.



22. Cut beside plastic rib as shown.



23. Refit bumper retention block.



24. Re-install LH and RH headlights using fasteners retained from step 19.



25. Paint Black the small area of panelling below the bumper retaining block. Ensure all surrounding areas of body work and lights are masked. Use a suitable automotive paint. Leave this area to dry while bumper and bar are prepared.

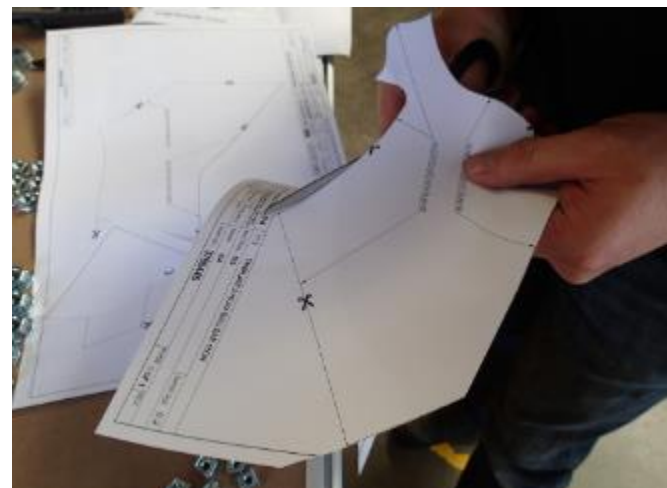

26. Carefully cut out both bumper cut templates supplied.

Note: Templates will be used for both sides (LH & RH) – be careful not to damage.

FITTING PROCEDURE - Continued

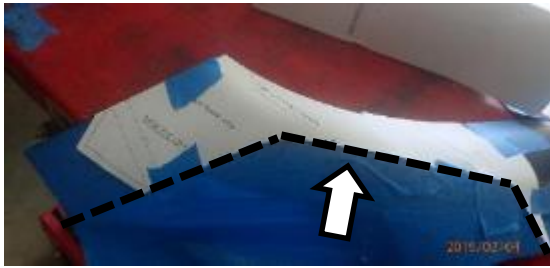

**ALIGN TOP EDGE TO
SMALL RIDGE IN
BUMPER**

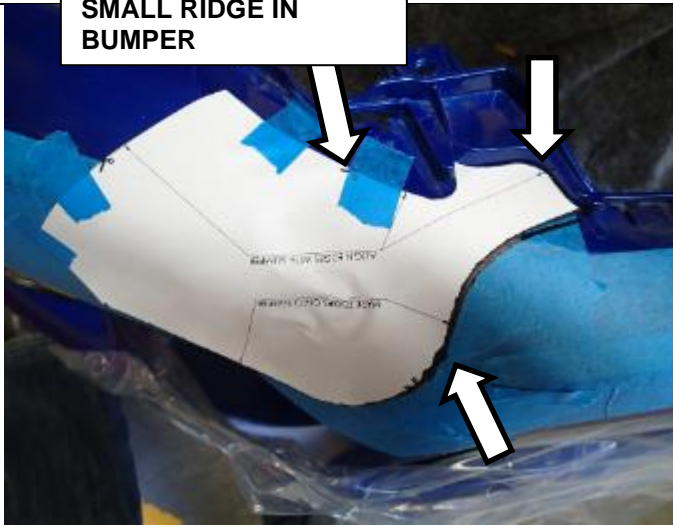

27. Position Template 3789462 onto RHS of bumper aligning with edges specified on template.
28. Stick masking tape onto bumper at area underneath template as shown running the tape well in towards the centre of the bumper.
29. Using a permanent marker, outline edges of bumper cut template onto masking tape where the bumper cut will be performed.
Remove template and repeat the above for LHS. Take care not to rip template upon removal.

30. Position Template 3789446 onto RHS of bumper. Align the profiled shape at the top corner of the template with the corresponding profiled area on the bumper whilst aligning with the ridge on the bumper as specified on template.
31. Stick masking tape onto bumper at area underneath template as shown running the tape well outwards to meet the tape from the outside of the bumper.
32. Using a permanent marker, outline edges of bumper cut template onto masking tape where the bumper cut will be performed.

Remove template and repeat the above for LHS. Take care not to rip template upon removal.



33. Apply a generous amount of masking tape in the area indicated on the bumper.
34. Use a steel rule or tape measure, mark a straight line joining the inner and outer lines created in the previous steps.
35. Repeat above for LHS. Carefully cut bumper along marked lines using a Multi Tool or jig saw and remove all masking tape.
36. Repeat for LHS.
Dispose of lower/centre portion of cut bumper.



Warning: Drilling operations can result in flying metal debris, safety glasses should be

FITTING PROCEDURE - Continued



37. Apply bumper trim pinch weld to both RH and LH sides. Use the 480mm length on the outer edge and the 88mm on the inner.



FITTING PROCEDURE - Continued



38. Re-install trimmed bumper ends and grille using retained OE fasteners.



39. Using a 5mm – 6mm drill bit carefully drill a hole through the upper front corners of the air deflector panels. (RH shown).



Warning: Drilling operations can result in flying metal debris, safety glasses should be



40. Using a 5mm – 6mm drill bit carefully drill a hole through the top face of the grille panel in line with the air deflector panel. (RH shown).



Warning: Drilling operations can result in flying metal debris, safety glasses should be



41. Cable tie the air deflector panels to the grille. (RH shown).

FITTING PROCEDURE - Continued

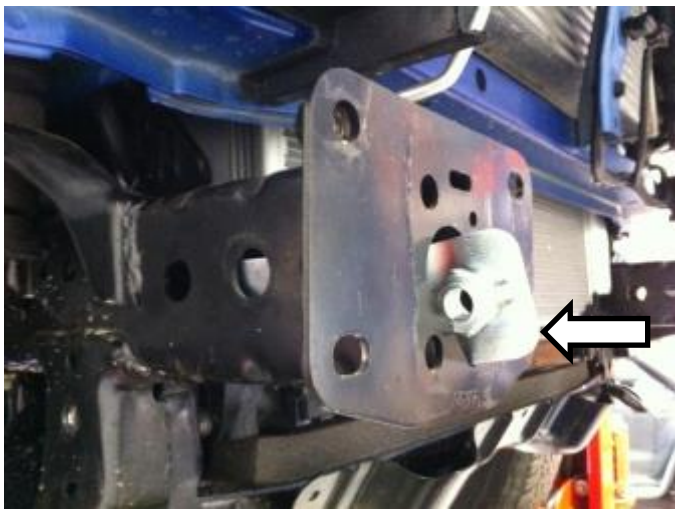

42. Insert 2 x M12x1.75 nut plate into RHS chassis rail as shown.

Note: 1 x nut plate is used to fasten the outer chassis support to the outside of the face of the chassis and 1 x nut plate is to fasten the inner chassis support to the inner face of the chassis. Install nut plates accordingly.

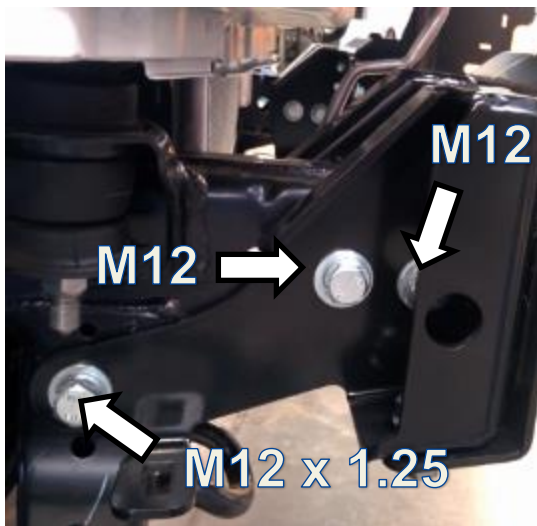

43. Loosely fasten RHS outer chassis support bracket to outside face chassis using 2x M12x1.75x35mm bolts, spring washer and flat washer installed through the front holes into the previously installed nut plate.

44. Loosely fasten the RHS outer chassis support bracket at the rear hole using M12 x 1.25 x 30 bolt, spring washer and flat washer installed into OE captive nut in the chassis bracing.



NOTE: IF USING A LARGE SIZE SOCKET, IT MAY BE NECESSARY TO PLACE THE SOCKET OVER THE FRONT BOLT BEFORE INSERTING AN EXTENSION THROUGH THE HOLE IN THE FLANGE.



45. Loosely fasten RHS inner chassis support bracket to inside chassis face using 2x M12x1.75x35mm bolts, spring washers and flat washers installed through the holes into the previously installed nut plate.

46. Repeat process to install chassis support brackets on LHS.

FITTING PROCEDURE - Continued



Washers

47. On both RH And LH installation it is extremely important that 1 x M10 x 25 x 3mm flat washer per hole is installed on the upper holes between the support brackets and the mount when offering the mount up to the chassis flange. The upper M10 bolts as installed in Step 49 should pass through the mount, spacer washers and the support brackets.



Washers

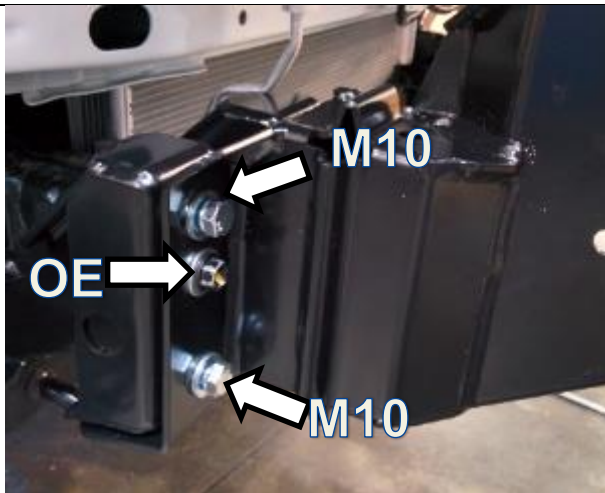

M10

OE

M10

48. Loosely install RHS Bullbar Mount onto chassis flange.

-Install M10x25x3 washers onto 2 x OE M10 bolts (retained at step 14) and re-install into the chassis flange captive nuts (positions as indicated).

49. Ensure 2 x M10x25x3 washers are installed between chassis support bracket and mount plate (as as from step 44).

50. Loosely install 4 x M10 x 30 SEMS bolts and 4 x M10 flange nuts through mount, flange and chassis support brackets.

NOTE: MOUNTS ARE HANDED. RIPPLES ARE ON THE OUTSIDE OF MOUNTS

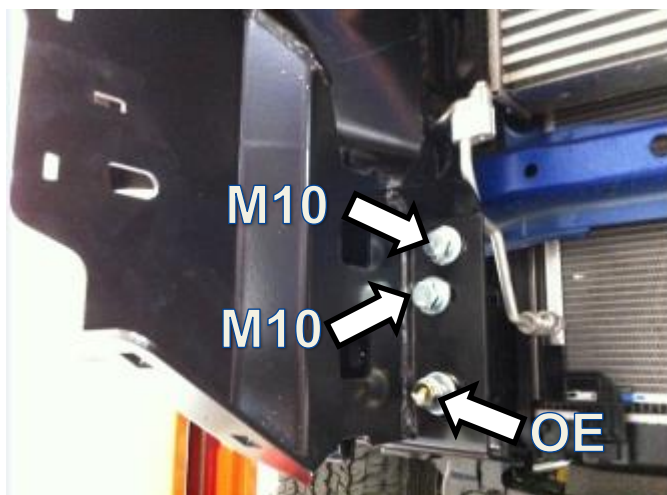

M10

M10

OE

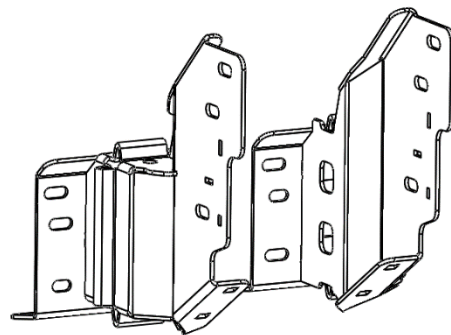

FITTING PROCEDURE - Continued

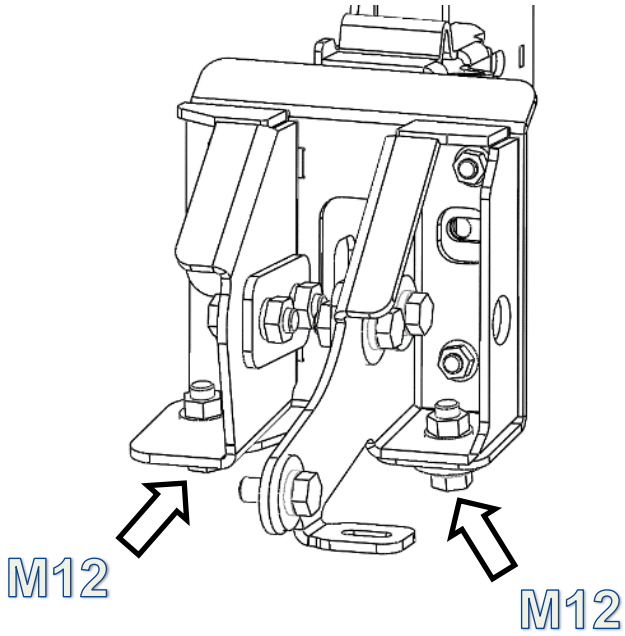

51. Loosely install 2 x M12 x 1.75 x 35 bolts, spring washers and flat washers through lower mount and chassis support brackets into M12 x 1.75 flange nuts.

Note: Starting with the M10 bolts installed from the front of the mount, tighten all fasteners enough to eliminate any play in mount or support brackets but to still allow for adjustment of bullbar.

52. Repeat process to install Bullbar mount on LHS.

FITTING PROCEDURE

Note: If fitting a winch proceed from here using fitting instructions 3789337 supplied with 3500720 winch install kit. Once the winch is fitted please continue to step 56. If no winch is being fitted continue from here.

53. Slide the winch cover panel from the bottom up until it is level with the top face of the bar.

54. Fit the winch cover panel to the bar using 4 x M6 x 20 hex bolts, spring washers, flat washers and flange nuts.

Warning: Be careful not to scratch the finish of the winch cover panel.

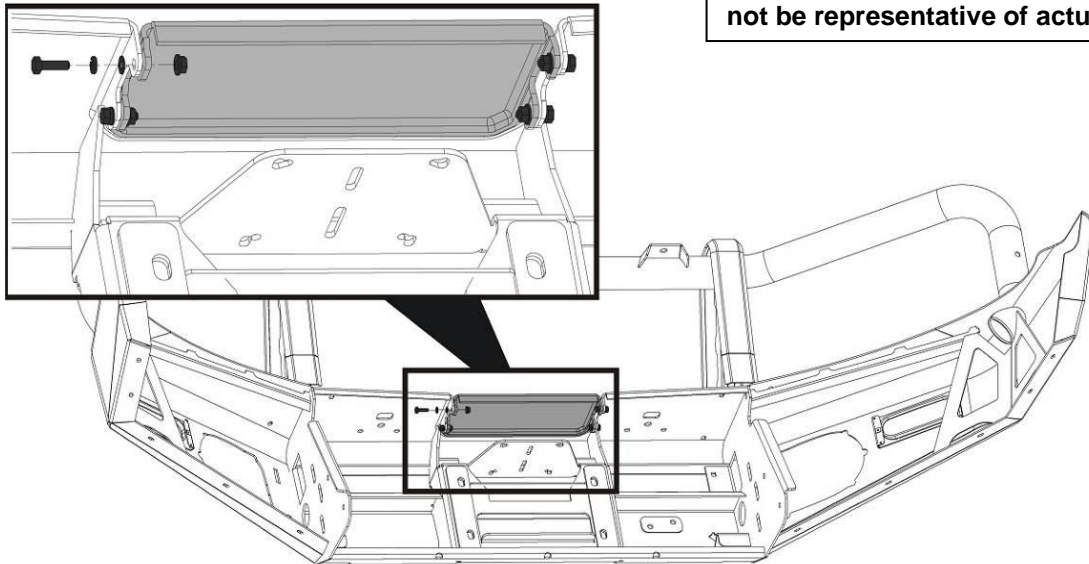

55. Fit the number plate bracket to the top face of the lower-centre pan on the bar using 3 x M6 x 20 hex bolts, spring washers, flat washers and flange nuts.

Note: If you are fitting a winch, fit the folding number plate bracket supplied in winch install kit "3500720 WINCH INSTALL KIT" – See fitting instructions 3789337

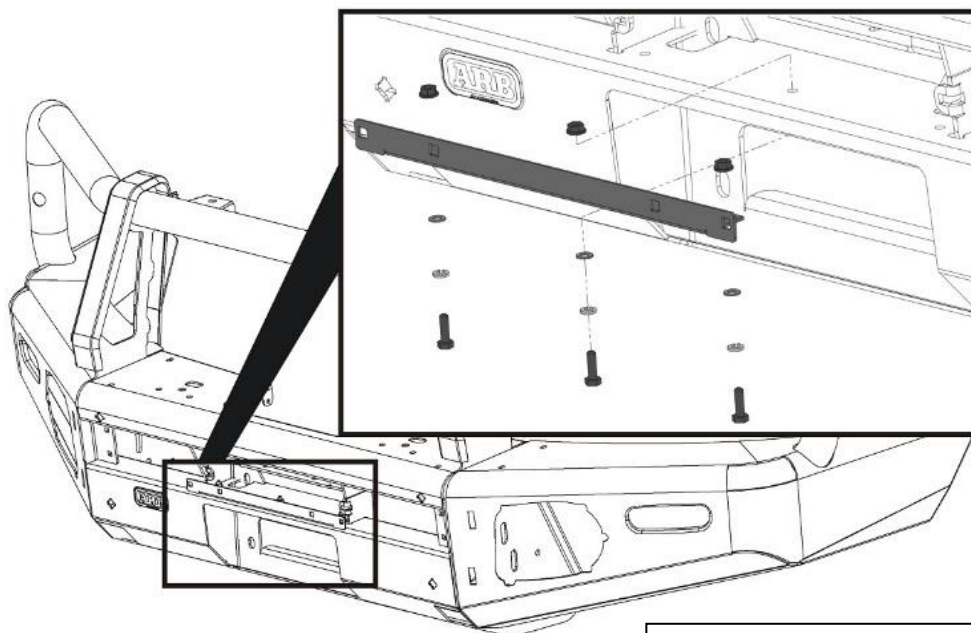

Note: The following steps show the fitment of the plastic moulded parts. The mouldings are supplied in kits along with all fasteners required for fitment. It is important that the fasteners supplied with each kit are only used for the mouldings from the same kit.

The kits included in this bar kit are as follows:

56. Layout the contents of each of the following kits ensuring the contents are kept separate from each other.

Kit No.	Description
5100200	BUFF KIT 2PCE FRONT SECTION
5100210	BUFF KIT 2PCE REAR UPRIGHT BAR
3500880	SPLIT PAN MESH KIT
3163082	FOG SURROUND KIT

57. Mark the grille panel to be cut at the 760mm marks at each end on the back face.

Note: When marked, double check the measurement with a measuring tool.

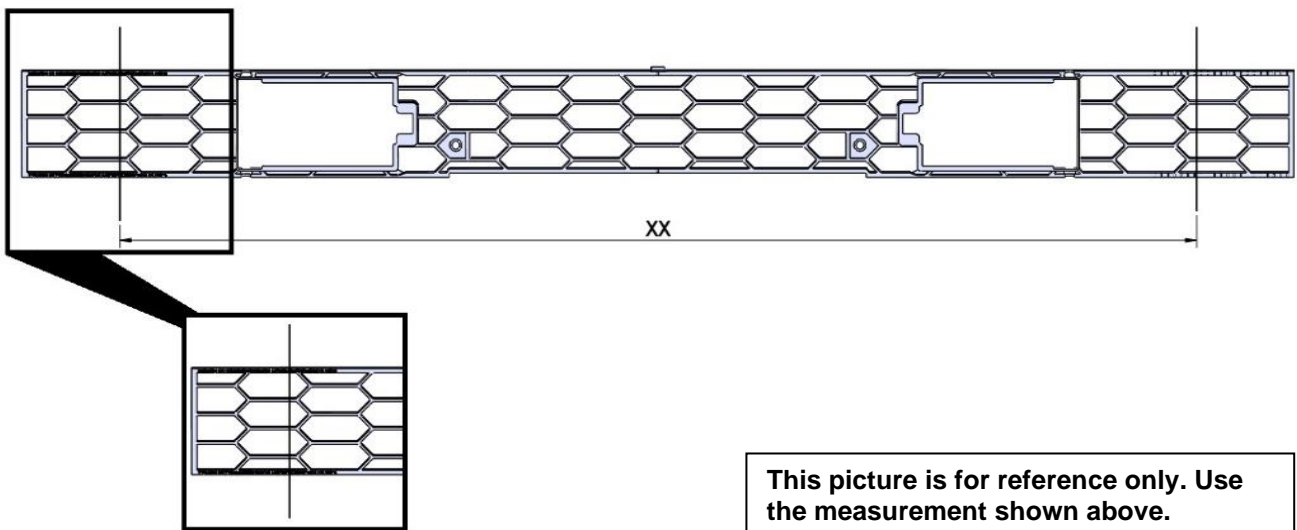

This picture is for reference only. Use the measurement shown above.

58. Use a hacksaw or similar cutting tool to carefully cut the grille panel at the positions marked in the step above.

59. Discard the off cuts and clean up the cut edges using a file or sandpaper.

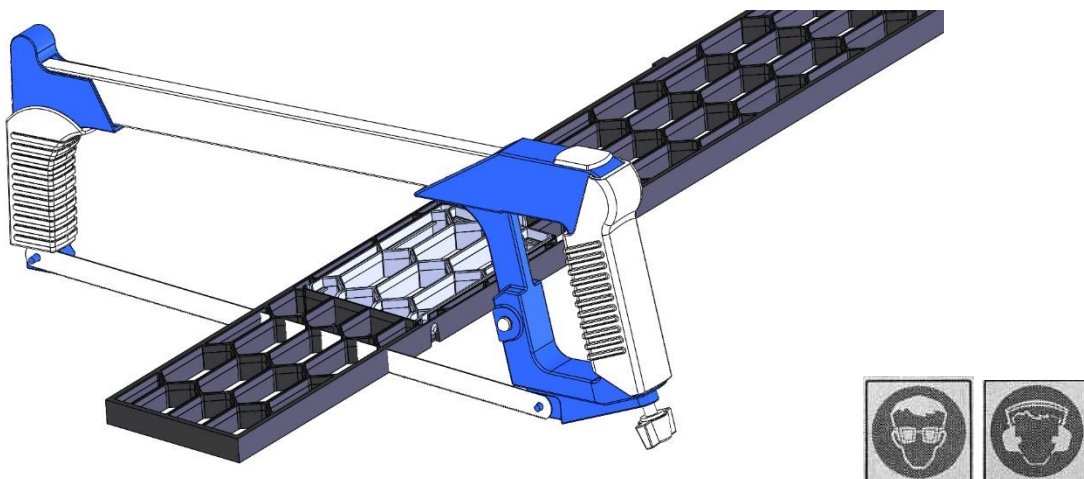

60. Insert the 6 x plastic grommets into the 6 square holes in the front face of the bar.
61. Insert the grille into the bar so that the hatches open outward (facing the front of the bar).
62. Attach the grille to the centre of the bar using the short screws into the grommets fitted above.
63. Attach the ends of the grille to the bar using the longer screws, through the clamp plates into the remaining grommets.

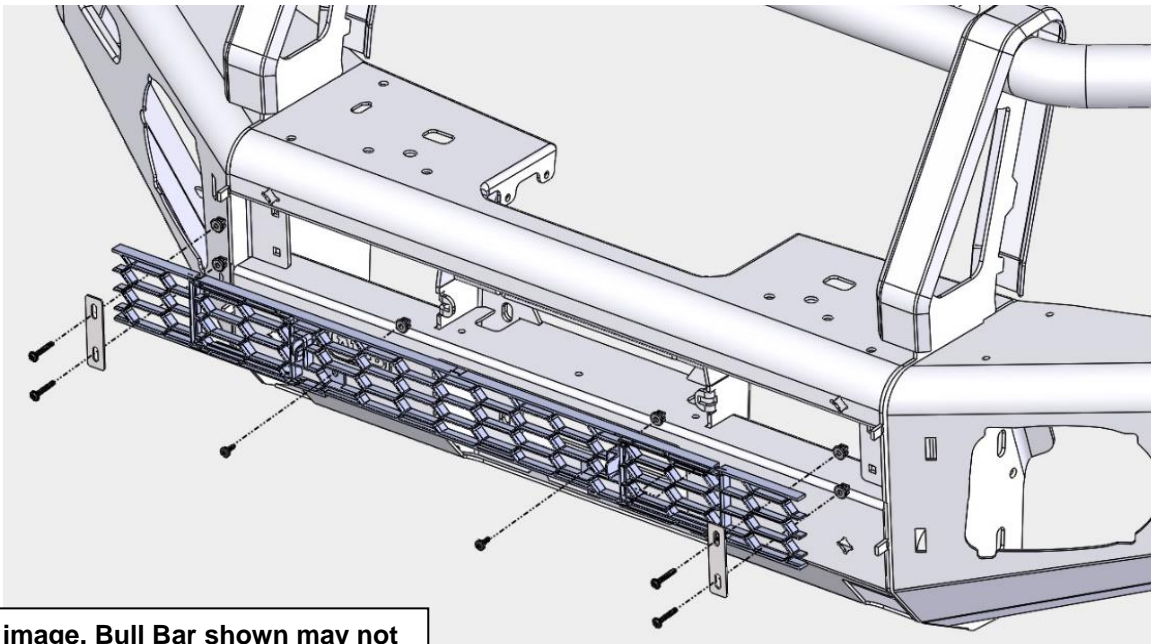

Generic image. Bull Bar shown may not be representative of actual product.

64. Fit the rubber intersection mouldings to the base of each upright cover strap.

Generic image. Bull Bar shown may not be representative of actual product.

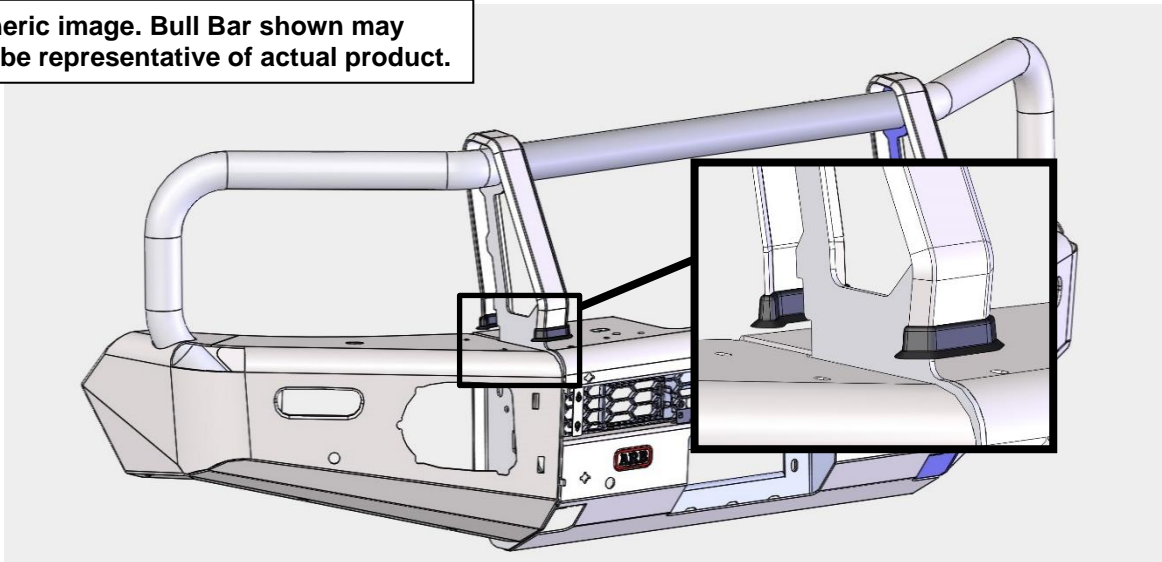

65. From the rear of the bar, slide the rear buffer sections under the rubber mouldings.

Fit 4 x screws and washers. Do not tighten screws. Leave enough play in buffers for adjustment later.

Note: Ensure that the skirts of the rubber intersection mouldings are not folded back on themselves and are sitting flat against the buffers.

Generic image. Bull Bar shown may not be representative of actual product.

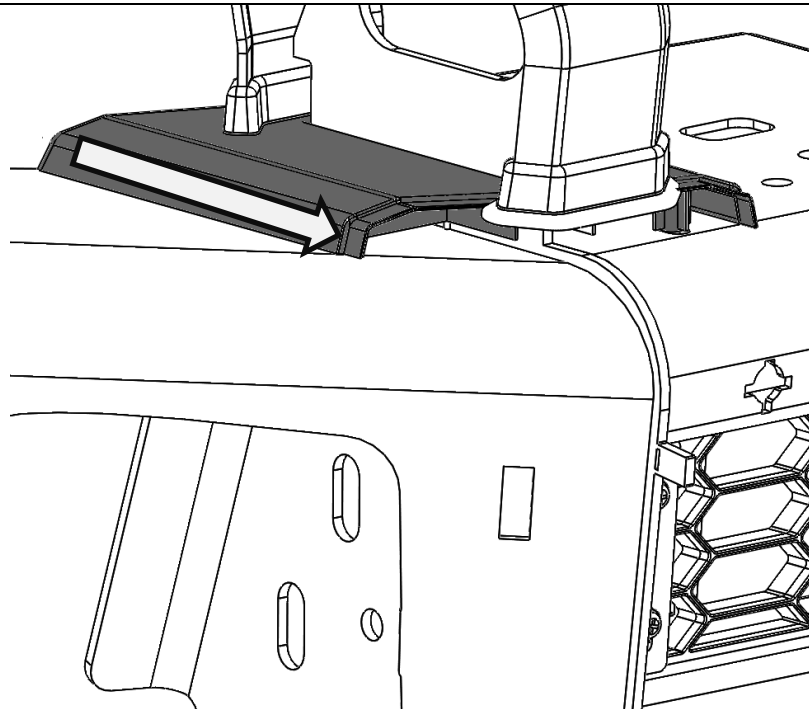

Fit washers under screw heads

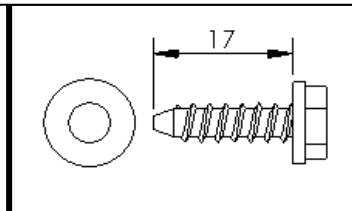

66. By aligning the front buffer with the tongue of the rear buffer, attach the front buffers to the front face of the bar. Ensure each buffer sits flat against the face of bar and is keyed into the top section of the rear buffer.

Secure wing side using retaining clips.

Secure inner side using the angled cup washers, flat washers and screws.

The widest point of the cup washers goes to the top of the bar.

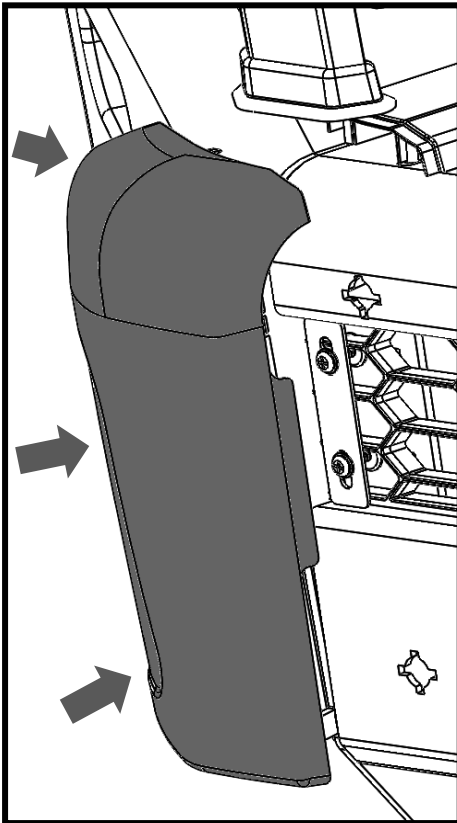

Generic image.
Bull Bar shown
may not be
representative of
actual product.

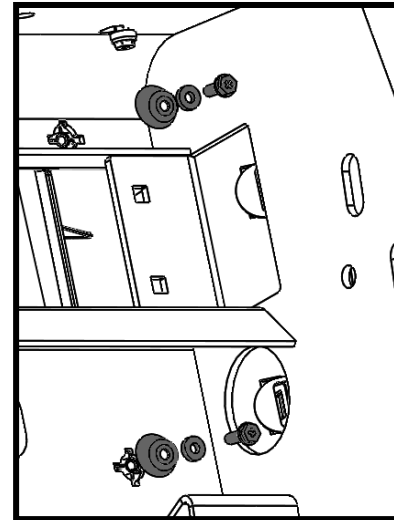

Fit washers under screw heads.

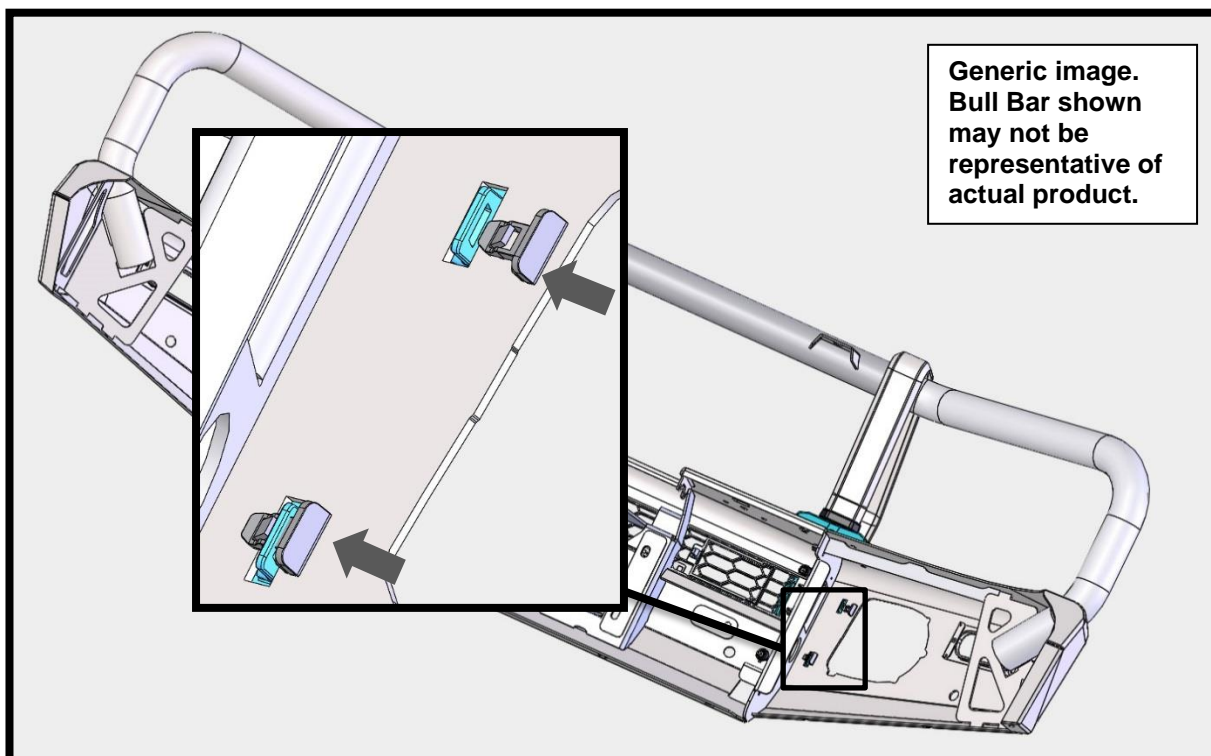
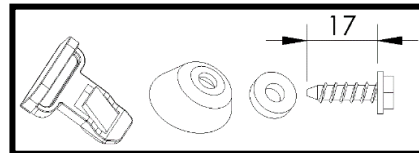

Generic image.
Bull Bar shown
may not be
representative of
actual product.

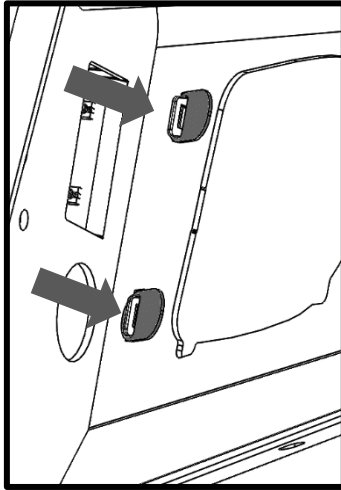

Fit 5848428 shims over tabs.
 Note: If clips are too tight to engage, shims may be removed to reduce tension

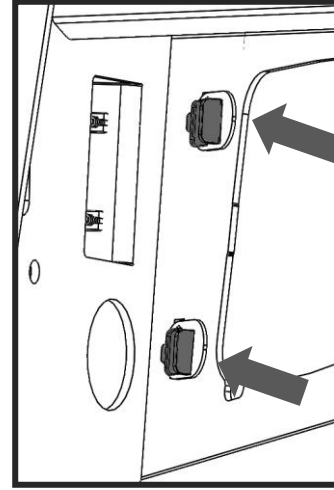

Slide retaining clips through tabs to lock buffer in place

FITTING PROCEDURE - Continued

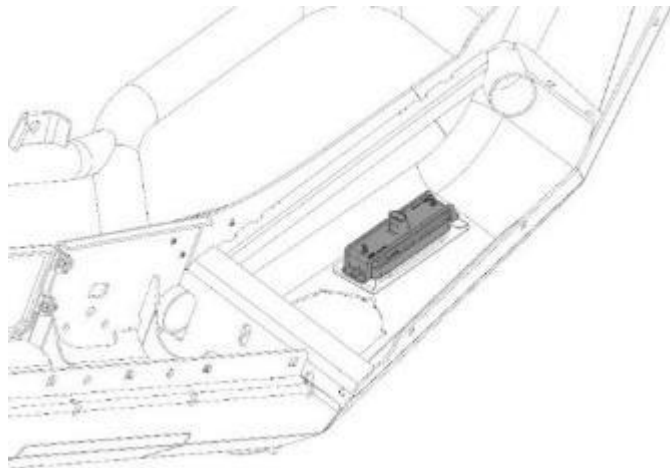

67. Fit the small plastic grommets to the bar and attach the combination LED lamps to the bar using the screws provided with the lamp kit.



68. With the assistance of another person, place the bar on the mount brackets.

Warning: Due to the weight of the bar and winch if fitted, it is advised that you use some form of mechanical assistance when lifting the bar onto the vehicle such as an elevating trolley.

FITTING PROCEDURE - Continued

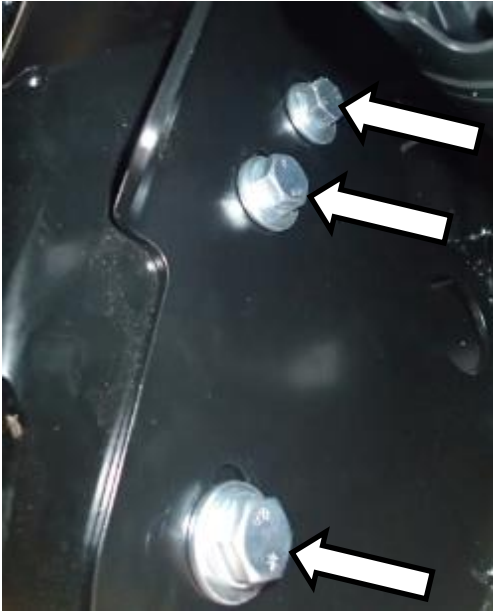

69. Loosely fasten bar to mounts using 6 x M12 x 1.75x35mm bolts, 6 x M12 spring washers, 6 x M12 flat washers (4mm thick) and 6 X M12 flange nuts.



70. Adjust position of bar left/right until it's sitting central to body, then tighten all fasteners joining mount assembly to chassis brackets (4x M10 and 2x M10 OE bolts each side).

 M10 – 44Nm

71. Tighten all inner and outer M12 chassis support bracket fasteners.

 M12 – 77Nm



FITTING PROCEDURE - Continued



72. Position the bar so that it is level with the bumper cut profile as shown and there is an even gap of 15-22mm between the wing edge and bumper cut trim.
73. Once bar is visually in correct position, tighten 6 x M12 fasteners joining bull bar to mount assembly.

 M12 – 77Nm



74. Drill 4 x Ø10mm holes (2 per side) through mount assembly using existing holes in bull bar as guide.
75. Add anti-corrosion touch up paint to area drilled.
76. Fasten 4x M10 SEMS bolts and flange nuts to pinning holes.

 M10 – 44Nm



Warning: Drilling operations can result in flying metal debris, safety glasses should be



- Assemble and install combination light surrounds (p/n 3163082) as per instructions no. 3789190 supplied with surround kit. Note: Optional fog lamps can be installed at this point as per fitting instruction supplied with fog lamp kit no. 3500590 and the 3500530 - ARB AUX Fog Light Loom kit.

CAUTION: Cable-tie all cables together and keep all cables clear of sharp edges and all moving parts.

77. Check the operation of all lights wired during bar fitment.

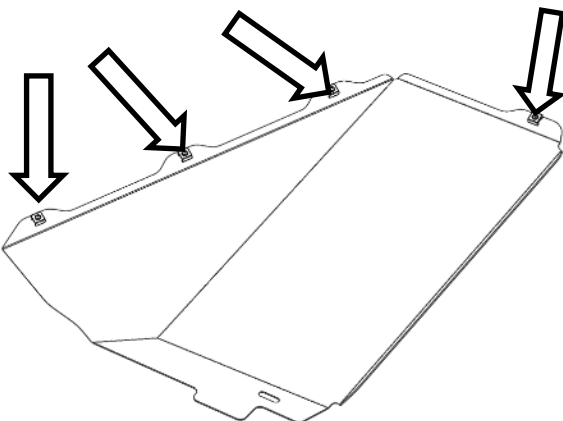

78. Fit 4 x M6 cage nuts to each wing under panel.

Note: Cage nut heads to be located on top side.

FITTING PROCEDURE - Continued

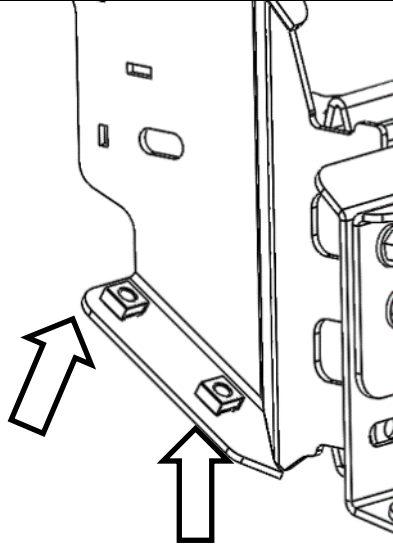

79. Fit 4x M8 cage nuts to RH and LH bull bar mounts as indicated. (RH Mount Shown)

Note: Cage nut heads to be located on top side of bull bar lip and mount assembly.

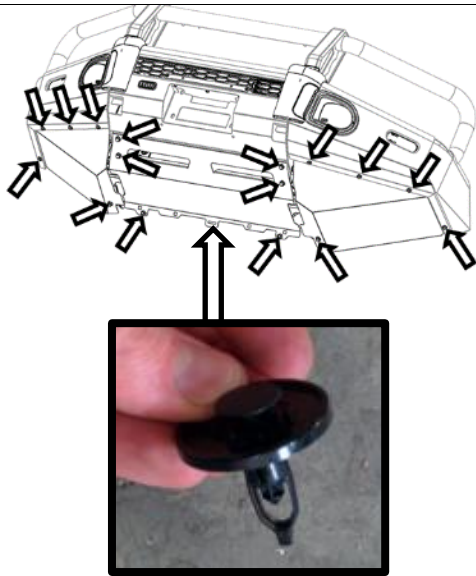

80. Fasten stone tray using 4x M8 bolts, flat washers and spring washers and 2x M6 OEM fasteners

Fasten wing under panels to bull bar using 8 x M6 bolts, 8 x M6 spring washers, 8 x M6 flat washers,

Fasten lower corner of wing under panel using 2 x M8x1.25x25mm bolts, M8 spring washers, M8 flat washers and M8 flange nuts

Fasten centre hole of stone guard using OEM clip shown.

 M6 – 9Nm  M8 – 22Nm

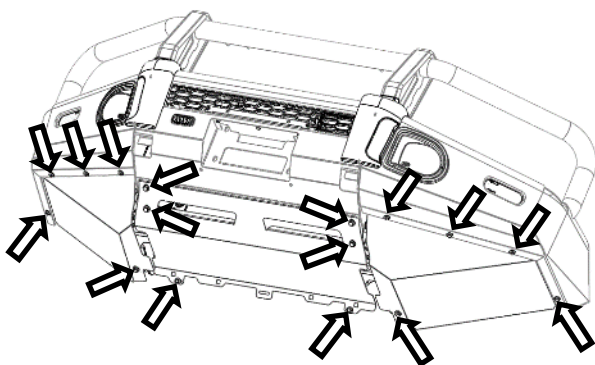

81. Fasten stone tray using 4x M8 bolts, flat washers and spring washers.

Fasten wing under panels to bull bar using 8 x M6 bolts, 8 x M6 spring washers, 8 x M6 flat washers,

Fasten lower corner of wing under panel using 2 x M8x1.25x25mm bolts, M8 spring washers, M8 flat washers and M8 flange nuts.

Fasten centre hole of stone guard using OEM clip shown.

 M6 – 9Nm  M8 – 22Nm

FITTING PROCEDURE - Continued



82. Mark lines onto the OEM inner guards (LH & RH) using lower edge of wing under panels as guide ensuring enough guard remains so that it may be neatly tucked/secured behind wing under panel lip.

Caution: Use care not to damage the windscreen washer bottle or hoses when trimming LH inner guard.

Note: Use a screwdriver or similar to carefully pry metal support (indicated) from inner guard before cutting.

83. Carefully cut along marked lines using jig-saw or shears.



Warning: Drilling operations can result in flying metal debris, safety glasses should be



84. In line with the bottom edge of the lower bumper trim and the top edge of the bulbar wing tip use a pair of shears to cut a section approximately 20mm x 20mm from the inner guard outer edge to allow it to be pushed into the end of the wing. (RH Shown).

85. Push inner guard panel inside the end of the wing and behind the rear lip of the wing underpanels.



86. From the scrivet clip removed from the vehicle earlier remove the scrivet screw and set aside.

FITTING PROCEDURE - Continued



87. Using a 7mm drill bit, drill the previously drilled 3mm holes in the inner guard and bumper out to 7mm.

Note: Pull the bumper end away from the inner guard (as pictured) and drill 1 x hole at a time rather than drilling straight through both holes.



88. Re-Install clip as shown and re-install clip scrivet.

89. If removed in earlier step, re-install upper scrivet.



90. Re-install upper radiator cover panel and fasten using 8 x OE scrivets.

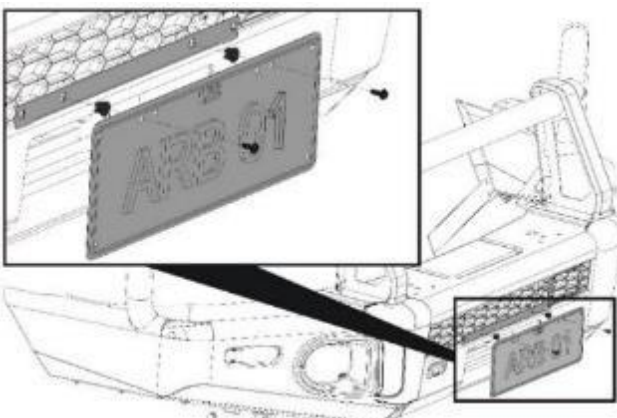

91. Fit the plastic plugs into the square holes in the registration plate bracket. Fit the registration plate to the bull bar using the black self-tapping screws.

92. Discard all remaining fasteners.

FITTED PRODUCT – TOYOTA HILUX Summit bull bar

ONCE BAR IS FITTED:

- ◆ Ensure all bolts are tensioned correctly.
- ◆ All wiring is clear of sharp edges or moving surfaces and is secured properly.
- ◆ Piping is secured well clear of sharp or moving components.
- ◆ Check operation of winch if fitted.
- ◆ Check all wiring and connections to turn signal lamps, sensors, headlamp washers etc. are functioning correctly.

