



FITTING INSTRUCTIONS

Part Number and Description: **2262010: Full modular bar**
 2262020: Lower bar and centre frame
 2262030: Lower bar only

Suited to vehicle/s: **2015on Chevrolet Silverado 2500HD and 3500**

WARNING

REGARDING VEHICLES EQUIPPED WITH SRS AIRBAG:

When installed in accordance with these instructions, the front protection bar does not affect operation of the SRS airbag.

ALSO, NOTE THE FOLLOWING:

- ◆ This product must be installed exactly as per these instructions using only the hardware supplied.
- ◆ In the event of damage to any bull bar component, contact your nearest authorised ARB stockist. Repairs or modifications to the impact absorption system must not be attempted.
- ◆ Do not use this product for any vehicle make or model, other than those specified by ARB.
- ◆ Do not remove labels from this bull bar.
- ◆ This product or its fixing must not be modified in any way.
- ◆ The installation of this product may require the use of specialized tools and/or techniques
- ◆ It is recommended that this product is only installed by trained personnel
- ◆ These instructions are correct as at the publication date. ARB Corporation Ltd. cannot be held responsible for the impact of any changes subsequently made by the vehicle manufacturer
- ◆ During installation, it is the duty of the installer to check correct operation/clearances of all components
- ◆ Work safely at all times
- ◆ Unless otherwise instructed, tighten fasteners to specified torque

ARB 4x4 ACCESSORIES

Corporate Head Office

42-44 Garden St
Kilsyth, Victoria
AUSTRALIA 3137

Tel: +61 (3) 9761 6622
Fax: +61 (3) 9761 6807

Australian enquiries
North & South American enquiries
Other international enquiries

sales@arb.com.au
sales@arbusa.com
exports@arb.com.au

www.arb.com.au

GENERAL CARE AND MAINTENANCE

By choosing an ARB Bar, you have bought a product that is one of the most sought after 4WD products in the world. Your bar is a properly engineered, reliable, quality accessory that represents excellent value. To keep your bar in original condition it is important to care and maintain it following these recommendations:



- As part of any Pre Trip Preparation, or on an annual basis, it is recommended that a thorough visual inspection of the bar is carried out, making sure that all bolts and other components are torqued to the correct specification. Also check that all wiring sheaths, connectors, and fittings are free of damage. Replace any components as necessary. This service can be performed by your local authorized ARB Stockist.

FITTING REQUIREMENTS

REQUIRED TOOLS FOR FITMENT OF PRODUCT:

METRIC SOCKET SET	METRIC RING AND OPEN-ENDED SPANNER SET
MATT BLACK PAINT	PHILLIPS AND FLAT BLADE SCREW DRIVER
TAPE MEASURE	HYDRAULIC LIFTING PLATFORM OR MECHANICAL LIFTING AID.
TRIM REMOVAL LEVERS	TORQUE WRENCH
KNIFE/SHEARS	

HAVE AVAILABLE THESE SAFETY ITEMS WHEN FITTING PRODUCT:

Protective eyewear		Hearing protection	
--------------------	---	--------------------	---

NOTE: 'WARNING' notes in the fitting procedure relate to OHS situations, where to avoid a potentially hazardous situation it is suggested that protective safety gear be worn or a safe work procedure be employed. If these notes and warnings are not heeded, injury may result.

FASTENER TORQUE SETTINGS:

SIZE	Torque Nm	Torque lbft
M6	9Nm	7lbft
M8	22Nm	16lbft
M10	44Nm	32lbft
M12	77Nm	57lbft

- ARB INTENSITY LIGHTS, UP TO 900 SERIES ROUND OR 800 RECTANGULAR DRIVING OR FOG LAMPS SUIT THIS PRODUCT
- BAR IS DESIGNED TO ACCOMMODATE WARN ZEON 12 AND WARN 16.5TI WINCHES

PARTS LISTING

APPLICATION	PART NUMBER	QTY.	DESCRIPTION
CENTRE SECTION TO VEHICLE	180302	10	CABLE TIE 4.8 X 180 MM BLACK
	3163091	8	PLUG BLANKING BLK 17.4mm (0-6.4mm PLATE)
	3314978	1	CENTRE SECTION ASSEMBLY CHEV 2500
	3752000	1	BRACKET LICENSE PLATE
	3759447L	1	BRACKET TOWHOOK LH CHEV 2500 15ON
	3759447R	1	BRACKET TOWHOOK RH CHEV 2500 15ON
	3759448	1	BRACKET FAIRLEAD CHEV 2500 15ON
	3759452L	1	BRACKET PARK SENSOR IN LH 2500 15ON
	3759452R	1	BRACKET PARK SENSOR IN RH 2500 15ON
	3759453	2	BRACKET PARK SENSOR OUT 2500 15ON
	3759484	2	BRACKET CHASSIS MOUNT 2500 15ON
	4581049	10	WASHER FLAT, M12
	4581064	10	WASHER SPRING M12 TZP480
	4581081	2	WASHER FLAT, M8 SS
	4581094	2	WASHER SPRING M8 x 3/32 x 3/32 SS
	4581304	16	WASHER FLAT, M6 SS
	4584325	2	WASHER SPRING M8 BLACK
	4584328	2	WASHER F M8 x 19 x 1.2 BLACK
	5848421	4	PACKER 1MM CHEV 2500 15ON
	5848422	8	PACKER 2MM CHEV 2500 15ON
	6151094	10	BOLT M12 x 1.25 x 30 Gd 8.8 ZP
	6151128	16	NUT FLANGE M6 x 1.0 ZP
	6151184	2	CAP SCREW M8 X1.25X30 SS NYLON PATCH
	6151256	16	Screw M6x16 Button S/S
	6151321	19	NUT FLANGE M10 x 1.5 ZP
	6151357	19	BOLT SEMS M10 X 30 ZP Gd 8.8
	6151480	10	NUT FLANGE M12 X 1.25 ZINC SILVER
	6151546	2	BOLT HXHD M8 x 1.25 x 25 GR8.8 BLACK
	6151548	4	NUT FLANGE M8 x 1.25 GR8.8 BLACK
	6522939	1	PANEL WINCH COVER
	6522975	1	PANEL ASSY CHEV 2500 15ON

APPLICATION	PART NO	QTY	DESCRIPTION
WINGS TO BULLBAR	3131486L	1	WING ASSEMBLY LH CHEV 2500 15ON
	3131486R	1	WING ASSEMBLY RH CHEV 2500 15ON
	3163091	2	PLUG BLANKING BLK 17.4mm (0-6.4mm PLATE)
	3500590	1	FOG LIGHT KIT
	3500640	1	ARB AUX FOG LIGHT ADAPTOR
	3759446L	1	BRACKET WING BRACE LH CHEV 2500 15ON
	3759446R	1	BRACKET WING BRACE RH 2500 15ON
	4581049	10	WASHER FLAT, 1/2 x 1 1/8 x 3 GOLD ZN
	4581050	10	WASHER SPRING 1/2 x 3/16 x 3/16 ZP
	6151094	10	BOLT M12 x 1.25 x 30 Gd 8.8 ZP
	6151321	8	NUT FLANGE M10 x 1.5 ZP
	6151357	8	BOLT SEMS M10 X 30 ZP Gd 8.8
	6151480	10	NUT FLANGE M12 X 1.25 ZP
TOP FRAME	5665933	1	TOP FRAME ASSY
	5665935	2	UPRIGHT END PANEL
	3759392	2	BRACKET ASSY CENTRE FRAME
	4581094	24	WASHER SPRING M8 SS
	4581081	24	WASHER FLAT, M8 SS
	5811060	12	SLEEVE M8 THREAD F TRUCK
	6151263	24	SCREW M8 X 1.25 X 20 S/S SHCS
	6151671	4	SCREW M12x1.75x40 SHCS SS
	4584354	4	WASHER FLAT M12 SS
	4584355	4	WASHER SPRING M12 SS
OUTER FRAMES TO BULLBAR	4581049	2	WASHER FLAT, M12
	4581050	2	WASHER SPRING M12
	6136380L	1	FRAME OUTER ASSY LH 2500 15ON
	6136380R	1	FRAME OUTER ASSY RH 2500 15ON

VEHICLE PREPARATION



1. Remove engine bay cover to expose top of grille as shown.
2. Unbolt the 4x circled bolts along the top edge of the grille.

3. Remove grille from car. It is shown off the car below to show all the clip locations.

Holding the top edge are 4x clips beside each of the bolts removed in the previous step. Lever these up to disengage. Make sure to disengage all of these before moving on!

Next, lever out the 12x clips protruding out the back of the grill. The image below shows the grille after it is removed. The clips can be seen protruding out the back. Use a plastic lever to avoid damage.



4. Underneath the bar, unbolt the wing braces and unplug the loom.

To unplug the loom, first pull out the red slider, than push in the black clip.

Remove the small Torx screw holding the inner guard at the junction of the front fender and Original bumper

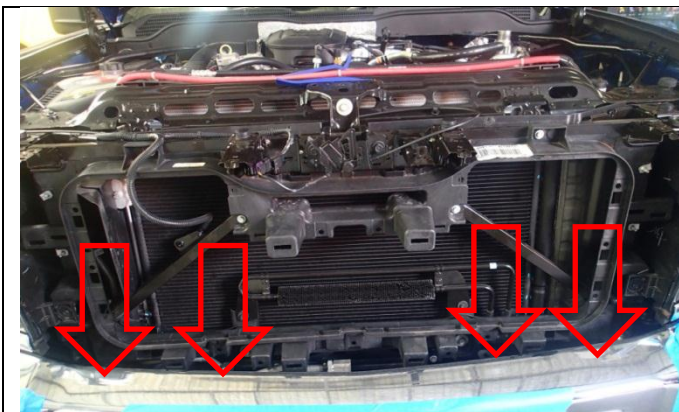

5. Support the weight of the bar and remove the 4x vertical bolts holding the bar in place.

Slide the bar forward taking care to unhook the inner guard liners and wiring loom.



6. Once the bumper is off, remove the original bumper brackets from the chassis, and retain the bolts.



7. Remove the reinforcing from behind the OE bumper. Remove the original wiring loom and park sensors. Remove park sensors by spreading tabs apart and sliding sensors out the back face of the bar.
DO NOT LOSE THE THIN RUBBER WASHERS AROUND THE FRONT FACE OF THE SENSOR.

Note the placement of the sensors in the original bumper as they need to be fitted in the same order in the bullbar.

Bar assembly



8. Secure the lower centre bar on a sturdy trolley or bench.



9. Fit the wings to the centre section using the 10x M12 bolts, flat washer, spring washers and flange nuts from the wing fitting kit. Align the wings to the front and top face of the bar as shown. Have an assistant hold and align the wings, then tighten the bolts.



M12 - 77 Nm.

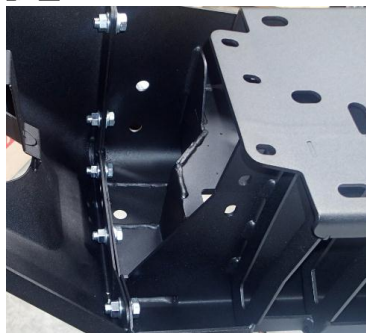

M12 - 77 Nm.

10. Skip to step 14 if you are not fitting the top frame. Place the top frame on the centre section. Fit using the reinforcing plates, stainless steel cap screws, spring washer and flat washer shown. Adjust the top frame so that it is symmetrical on the centre section.





11. Loosely secure the joining sleeves to the upright using:

16x M8 stainless socket head screws
 16x M8 stainless flat washers
 16x M8 stainless spring washers

Fit the inner M8 cap screws, spring washers, flat washers and sleeves to the sides of the top frame. Leave these slightly loose to make fitting the outerframes or blanking plates easier.

12. If no outerframes are to be fitted, secure the blanking plates to each side of the upright using the M8 stainless cap screw, flat washer and spring washers.

 **M8 - 22 Nm.**



13. If fitting outer frames, use the M12 bolt, flat washer and spring washer provided in the outer frame kit to loosely secure the end of the outer frame to the wing.

Use the 16x M8 stainless cap screws, spring washer and flat washers to the sleeves fitted in the previous step.

Loosely fit all the outer frame fasteners before tightening them.

Fully tighten the M12 bolt, before tightening the M8 screws.

 **M8 - 22 Nm.**  **M12 - 77 Nm.**

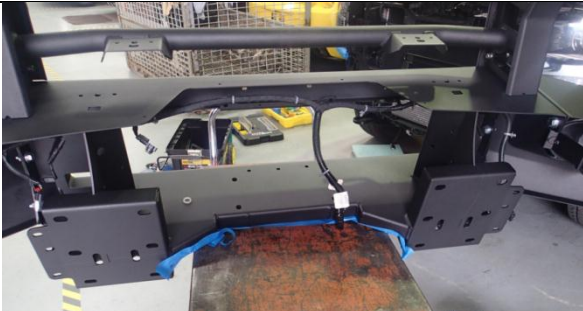

14. Fit parking sensors and loom to the bar as shown, ensure the original order of parking sensors is maintained. Route the loom across the back of the upper pan of the bar.

Secure using the brackets with 8xM6 dome head bolt, flat washers and flange nuts and cable tie the loom in place.

Depending on model, parking sensors may be silver. If desired, These can be painted with a thin matt black paint in order to match the bar.

 **M6 - 9 Nm.**

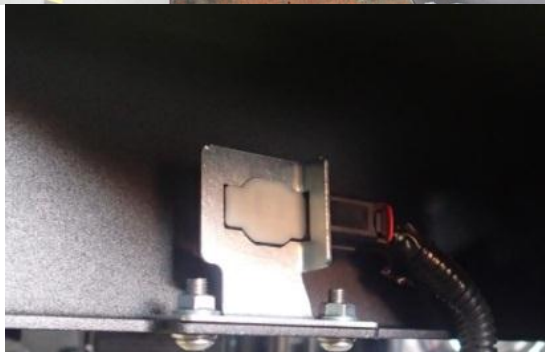

Right hand side inner sensor and bracket



Right hand side outer sensor and bracket



15. Remove globe from fog light by twisting anti clockwise.
Slide fog light into adapter. Ensure that the clips on each side and the rear clip engage fully. Be sure that the tag under the rear clip remains in its locating hole as shown below. Reinstall globe.



Original loom

16. Cut the original fog light plug off the OE loom. Crimp the bullet terminals onto the OE loom. Ensure you connect the black wire on the ARB adapter loom to the black wire on the original loom. Insulate join with heat shrink or electrical wrap.

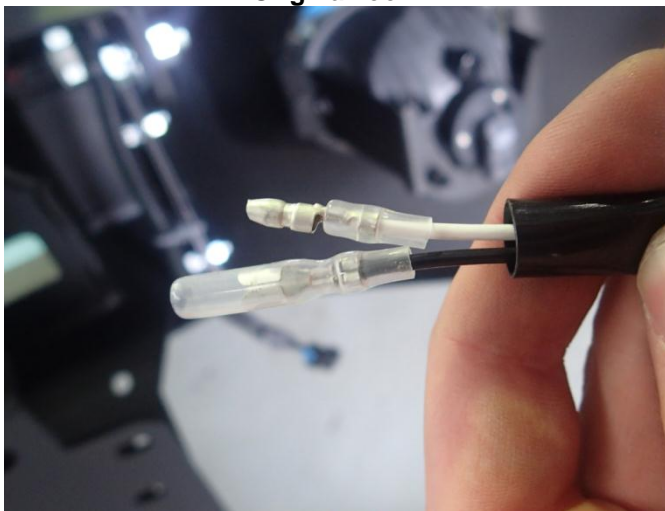

ARB adapter loom

WINCH FITTMENT

This bull bar has been designed to fit Warn Zeon and Warn 16500lb winches. No supplementary parts are required for fitment of these winches.

It is important that a winch of capacity greater than 16500lb is not fitted even if it physically fits into the bar.

Unless otherwise stated, fasteners used during fitment of winch are supplied with bull bar centre pan fitting kit.

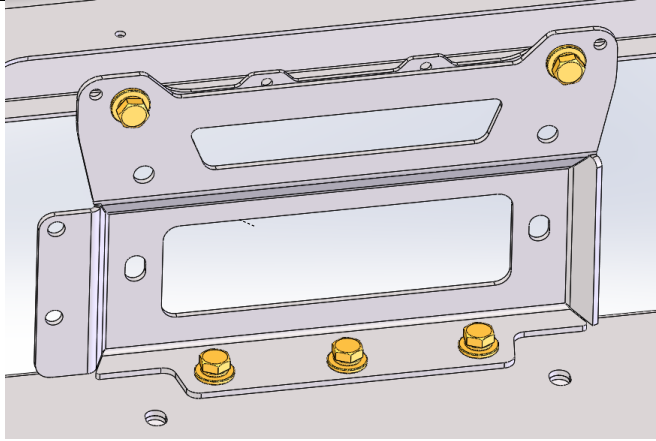

17. Fit fairlead bracket as shown using 5 x M10x30 SEMS bolts and flange nuts

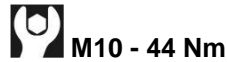

18. Secure fairlead to fairlead mount bracket using 2x M10x30 SEMS bolts and flange nuts

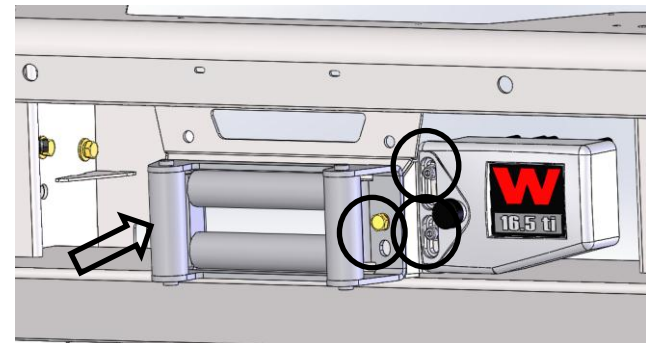

If fitting Warn 16.5 winch, fit control box as shown using the stainless M8 x30 caps screws, flat washers, spring washers and black M8 flange nuts

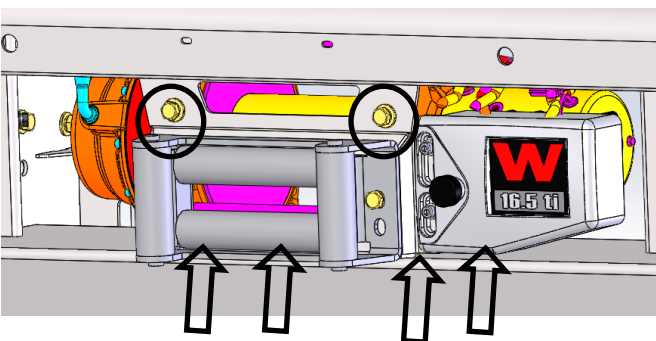

19. Fit the winch into the bar.

If fitting Zeon winch, use 4x M10x50mm bolts and nuts from Warn fitting kit.

If fitting Warn 16.5 use 6x 7/16 bolts from Warn fitting kit. 4x bolts are fitted to the lower pan. 2x are fitted to the fairlead bracket as shown



Wire up winch as per winch fitting instructions.

Bar Fitment

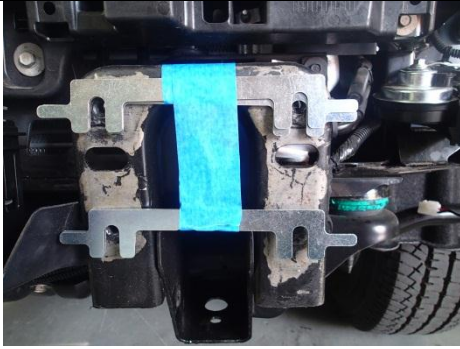

20. Tape fitment shims to the mounts as shown.
Upper: 1x1mm shim+ 1x2mm shim.
Lower: 1x1mm shim+1x2mm shim.

Note: Tape is just to hold shims in place while bar is fitted. It can be pulled out later if desired.



Tape is used under the headlights and under the bar to protect these areas from scratches during fitment.

21. Using a suitable lifting device, bring the bar to the vehicle chassis.

Secure to chassis mounts using the original fasteners.

Adjust bar such that:

Bar is symmetrical on the vehicle,

Wings are parallel to and approximately 20mm below the front fenders

Back edge of wings follows wheel arch lines.

Adjustments can be made by adding or removing shims.

Bar does not need to be removed to adjust shims. With the mount bolts loose, shims can be slid out or new ones dropped in.

If you have difficulty adjusting the bar, the wings may have been bolted on askew. In this case, loosen and correct wings.

Torque all bolts.



M12 - 77 Nm





22. Fit reinforcing bracket under chassis as shown. Use M12 x 30mm bolts, flange nuts flat washers and spring washers.

Snug up and progressively tighten the bolts together to ensure the bracket sits tightly against the chassis and the bull bar mount.

Torque all bolts.

 **M12 - 77 Nm**



23. Fit tow hooks and reinforcing brackets into the bar

Slide the tow hook through the front opening and loosely secure using original M12 bolt in underside of tow hook.

Drop reinforcing brackets over the top of the tow hook as shown.

First fit original M12x100mm bolt as shown then the 6x M10x30 SEMS bolts and nuts.

Torque all bolts.

 **M10 - 44 Nm**

 **M12 - 77 Nm**

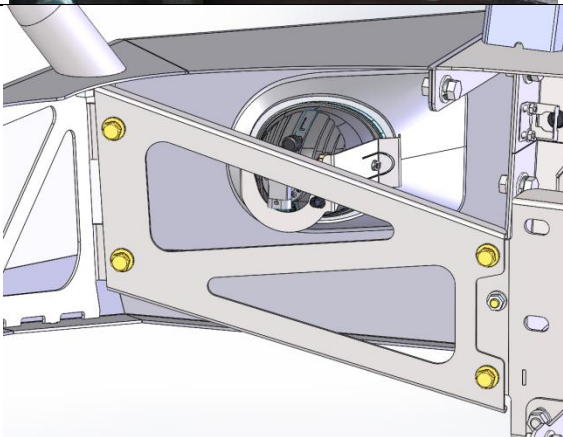

24. Fit wing braces using M10 x30 SEMS bolts and nuts from the wing fitting kit.

Note that the folds bend forward and the notched end is on the inside.

 **M10 - 44 Nm**

25. Feed wiring loom behind bar and plug into vehicle harness.



26. If no winch was fitted, fit the grill.

Use 4x M10x30 SEMS bolts, washers and nuts for the centre upper and lower bolts and M8 x25 bolts for the outer bolts.



M10 - 44 Nm



M8 - 22 Nm.



27. Fit number plate and bracket to upper pan using 4xM6x16 dome head bolts, flat washers and flange nuts.



M6 - 9 Nm.



28. If no winch was fitted, fit the winch cover panel to the upper pan.

Use M6x16 dome head bolts flat washers and flange nuts.

29. Reinstall grill and engine bay cover. Install is opposite of removal in step 1 and 2



M6 - 9 Nm.



30. Trim inner wheel arch liner hanging below the bar. Trim horizontally inwards from the underside of the bulbar wing.

FITTED PRODUCT

