

TOYOTA LANDCRUISER 60, 61 & 62 SERIES

Refer Section 1: General - General Fitting Hints & Procedures, and

CARRY OUT

- Removal of old suspension
- Suspension component prefitment check
- Installation of OME suspension

INSTALLATION HINTS AND SPECIAL NOTES:

TAIL SHAFT SLIP YOKE: Ensure grease nipple used for lubricating sliding sleeve yoke of tail shaft is removed - to allow any excess grease to escape. This will prevent hydraulic lock of the slip yoke. Replace nipple before test drive.

MILITARY WRAP: This end of the spring must be installed at the fixed end.

BRAKE PROPORTIONING VALVE: May need to be adjusted in line with vehicle manufacturer's workshop manual, (see Section 5: Problem Solving for further information).

DIFFERENTIAL BREATHER: Check that the breather remains attached on full suspension droop, fix if required.

BARN DOOR MODELS: These models appear to have a more even vehicle weight distribution and therefore A/A or B/B spring selection can be more appropriate.

STABILISER BAR: Ensure when new suspension is at full droop that the connecting links and stabiliser bar arms do not form a straight line because this will cause stabiliser bar inversion, (see pages 2&3).

When lowering differential housing do not stretch brake hose. It may be necessary to remove the brake hose clip.

TORQUE FIGURES

Item	lbs Torque	Nm Torque
U bolts	90	123
Shackle & fixed end pin	67	91
Hanger pin locating nut	9	13

When fitment of new suspension has been carried out complete 'Final Suspension Check Before Delivery' (see Section 1: General).

TOYOTA LANDCRUISER 60, 61 & 62 SERIES

REAR SUSPENSION STABILISER BAR MODIFICATION RE INVERSION

Note: The procedure below is applicable only to Original Equipment stabiliser bars and links.

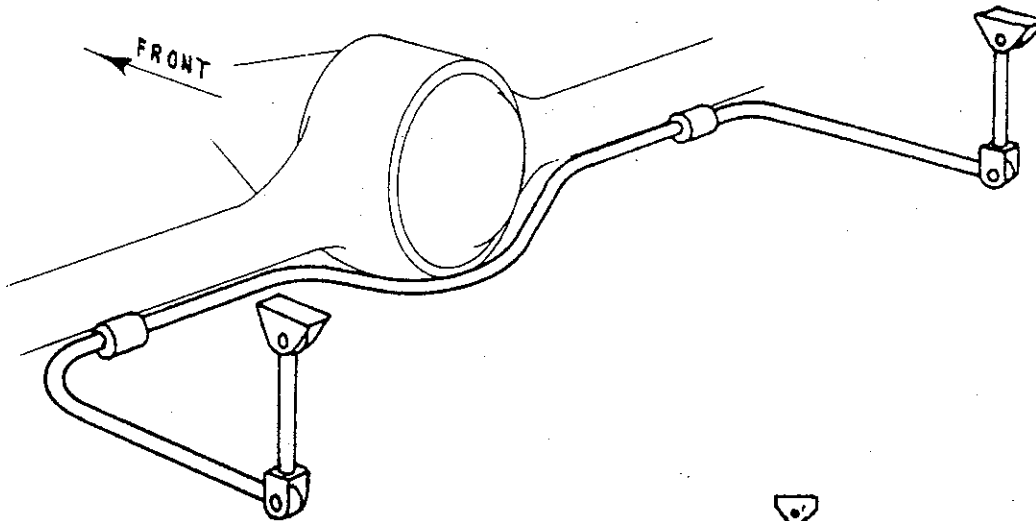

Suspension at normal ride height >>>

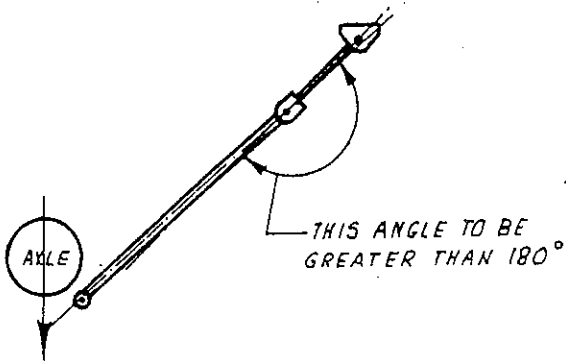
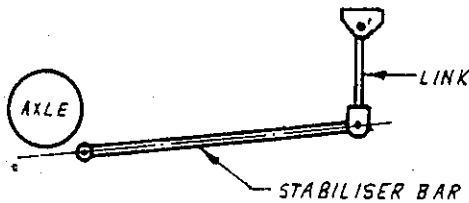

<<< Suspension at full droop (hanging on shocks).

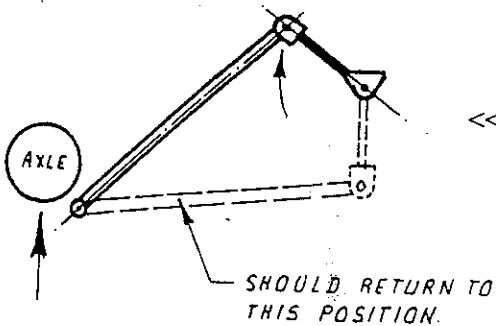

<<< Suspension returns to normal ride height but stabiliser bar legs and links go over centre, or invert. If there is a concern that this can occur, carry out the modifications following.

TOYOTA LANDCRUISER 60, 61 & 62 SERIES

REAR SUSPENSION STABILISER BAR MODIFICATION RE INVERSION

1. Remove links and dismantle any rubber bushes that may be fitted to them.

2.

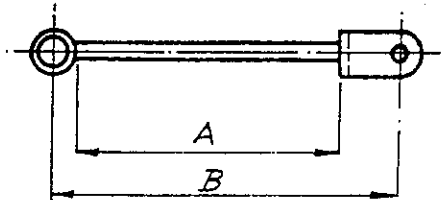

Measure dimensions A & B

3. Cut 2 pieces of thick walled tube (approximately 3mm) to the length of dimension A. The tube inside diameter is to be a neat fit over the link shank.

4.

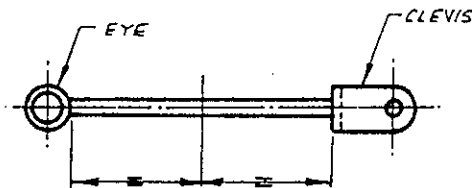

After noting angular relationship between the link clevis and link eye, cut link midway along shank.

5.

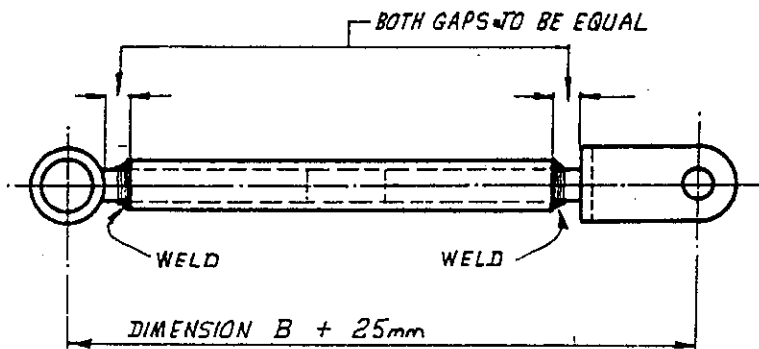

Assemble both halves of link and tube, set correct angular relationship between eye and clevis as noted in step 4. and weld together.

6. Refit rubber bushes and reassemble links on vehicle.

TOYOTA

LANDCRUISER 60, 61 & 62 SERIES

SHACKLE ANTI-INVERSION KIT PART NO. FK08

FRONT & REAR INSTALLATION

It is mandatory to fit an anti-inversion kit (or greasable shackles) to OME long travel suspension to prevent shackle inversion.

FITTING INSTRUCTIONS:

IMPORTANT: Before installing ensure suspension is at full droop.

1. Check shackle angle is no less than 5° + see diagram II. Should shackle angle be less than 5° lower vehicle until the correct angle is achieved.
2. Position FK08 plate with tapered end butting up to chassis while ensuring the plate covers the spring hanger bracket and both side plates, see diagram I. A 2mm gap between FK08 plate and shackle must be obtained, see diagram II. This may require the FK08 plate to be trimmed to the required length.
3. When shackle angle and 2mm gap are achieved tack weld both side plates. Check plate is correctly positioned before completing full welds both sides of plate to hanger bracket.
4. Clean welds & paint black.

diagram I - front view

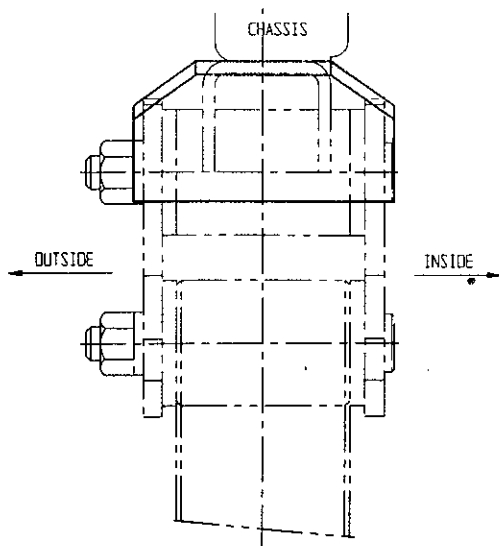
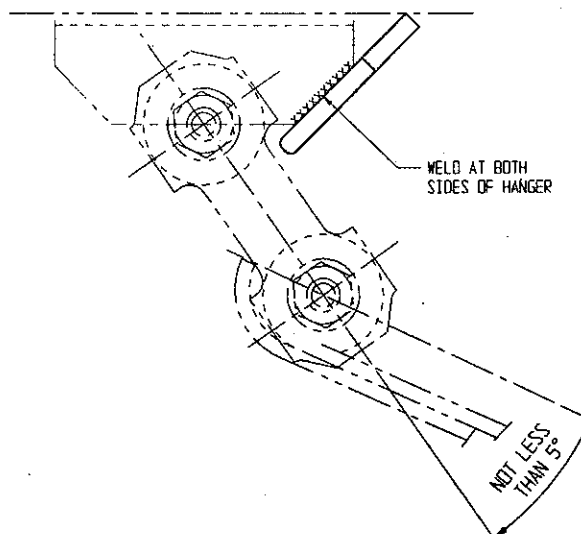

diagram II - side view



TOYOTA LANDCRUISER 60, 61 & 62 SERIES

GREASABLE SHACKLE INSTALLATION

GREASABLE SPRING SHACKLE
ASSEMBLY INSTRUCTIONS
PART NUMBERS: OMEGS1, OMEGS2.

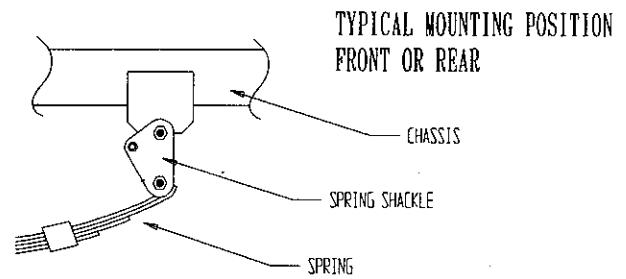

GENERAL ASSEMBLY

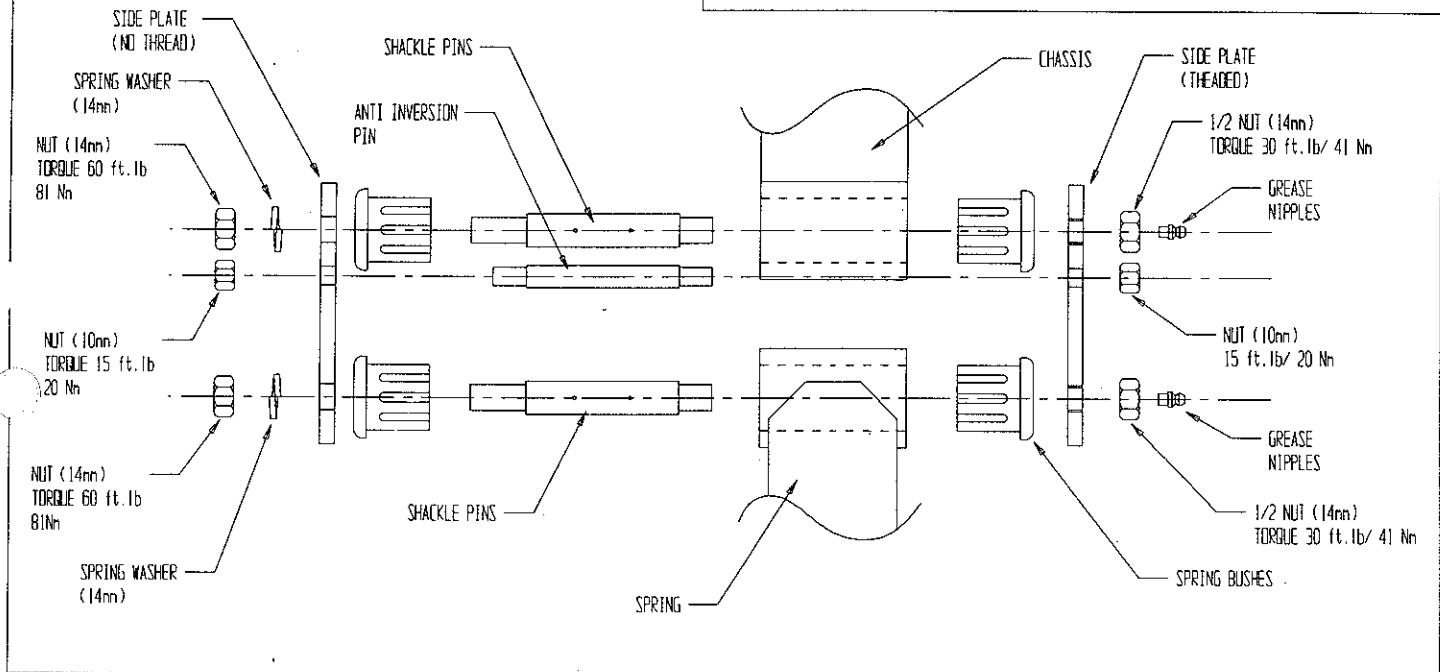

TOYOTA LANDCRUISER 60, 61 & 62 SERIES

GREASABLE FIXED END PIN INSTALLATION

GREASABLE SPRING SHACKLE
ASSEMBLY INSTRUCTIONS FIXED END
PART NUMBERS: OMEGP1, OMEGP2,
OMEGP3, OMEGP4

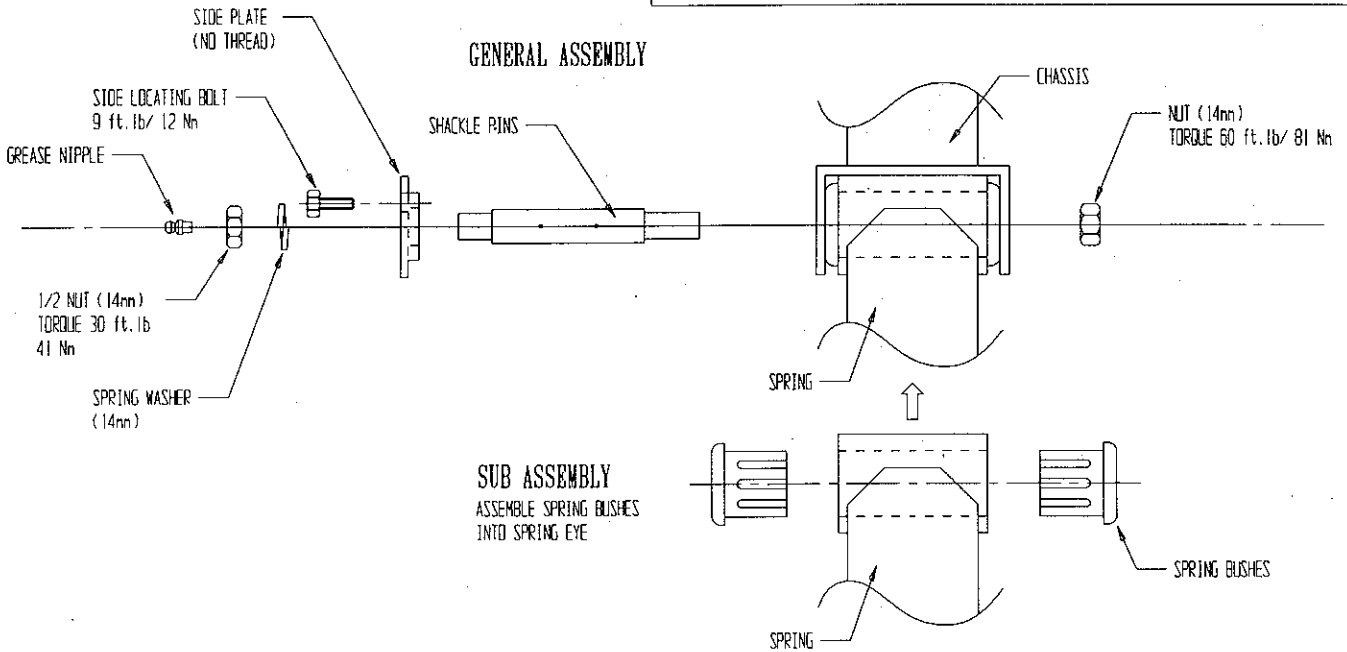
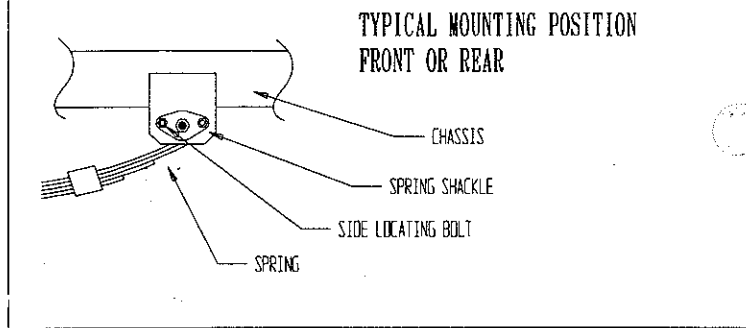

TOYOTA LANDCRUISER 60, 61 & 62 SERIES

REAR SUSPENSION: U BOLT & RETAINER SPACERS' SELECTION CHART

Application chart suits G, GX and Sahara models only.

Spring Type	OME221A/B	OME113A/B	OME1131 A/B
Stack height	48mm	58mm	64mm
Number of leaves second stage	-	2	2
60mm Retainer depth spacer required	-	FK0411	FK0418
54mm Retainer depth spacer required	FK047	FK0418	FK0418 & FK047
U bolt	OMEU59A	OMEU59B	OMEU59B

Note:

1. All FK04 series contain 4 spacers per kit.
2. FK01 fitting kits will need to be used if you run out of thread when tightening U bolts.

