



OLD MAN EMU

FITTING INSTRUCTIONS

FK69

Ford Superduty
2008 On F250/350
Panhard Bracket kit

HAND TOOLS REQUIRED

Ring / Open end Spanner set (Metric)
Socket Set (Metric)
Inc. 30mm and 24mm
Torque Wrench

WORKSHOP TOOLS REQUIRED

N/A

KIT CONTENTS

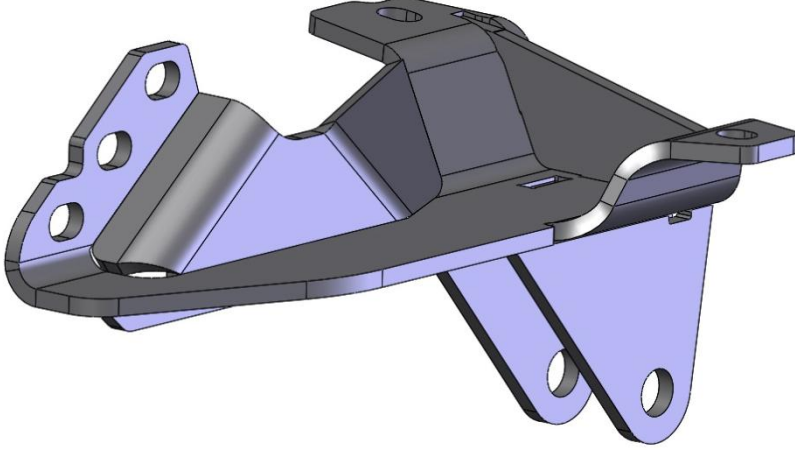
PART NO.	Qty.	DESCRIPTION	PICTURE
3759343	1	OME Panhard Bracket	

Fitment Notes

- This kit should be fitted after raised 4" suspension has been installed to re-centre the front axle.

Fitting Procedure

1. Remove upper panhard bolt using 30mm socket and 30mm ring spanner. Lower panhard rod.

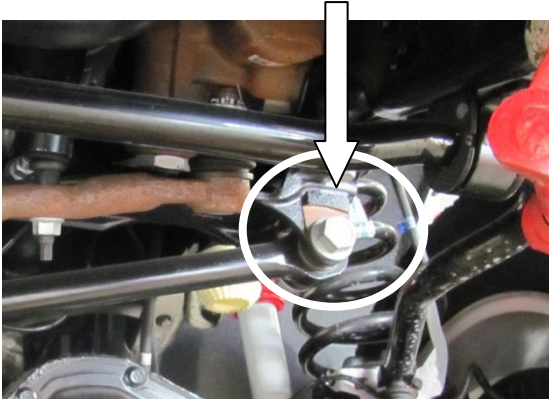

2. Remove OE Panhard Bracket, 3x M14 bolts at the engine cross member and 2x M14 bolts from underneath the chassis rail.

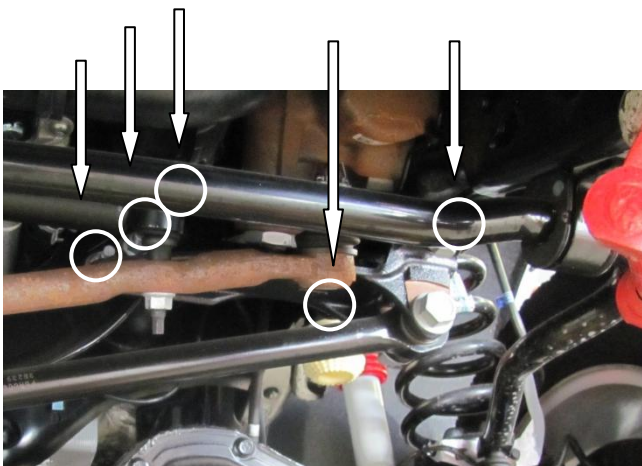

3. Replace with new OME Panhard Bracket re-using the OE bolts, loosely start all 5 bolts first then tighten.

Torque M14 bolts to 200Nm (140 lbf.ft)



4. Re fit upper panhard mount to new bracket using OE M18 Bolt, (If having trouble aligning get someone to turn the steering wheel.)

Torque M18 Bolts to 350 Nm (260 lbf.ft)

