

FITTING INSTRUCTIONS

BP5160036

TO SUIT DEFENDER 110 & 130 REAR

WARNING

- ◆ This product must be installed exactly as per these instructions using only the hardware supplied.
- ◆ In the event of damage to any suspension component, contact your nearest authorised ARB stockist. Repairs or modifications to the suspension system components must not be attempted.
- ◆ Do not use this product for any vehicle make or model, other than those specified by ARB.
- ◆ Do not remove labels from suspension components.
- ◆ This product or its fixing must not be modified in any way.
- ◆ The installation of this product may require the use of specialized tools and/or techniques
- ◆ It is recommended that this product is only installed by trained personnel
- ◆ These instructions are correct as at the publication date. ARB Corporation Ltd. cannot be held responsible for the impact of any changes subsequently made by the vehicle manufacturer
- ◆ During installation, it is the duty of the installer to check correct operation/clearances of all components
- ◆ Work safely at all times

Note: These fitting instructions should be read in conjunction with the vehicle workshop manual.

It is critical these BP-51 dampers are fitted with the correct coil springs. Refer to the Defender long travel page of the OME catalogue to select the appropriate springs for your application.

Caution: Front drive shaft MUST be replaced / modified with Double Cardan Joints and checked for Uni bind with BP-51 installed at full droop.

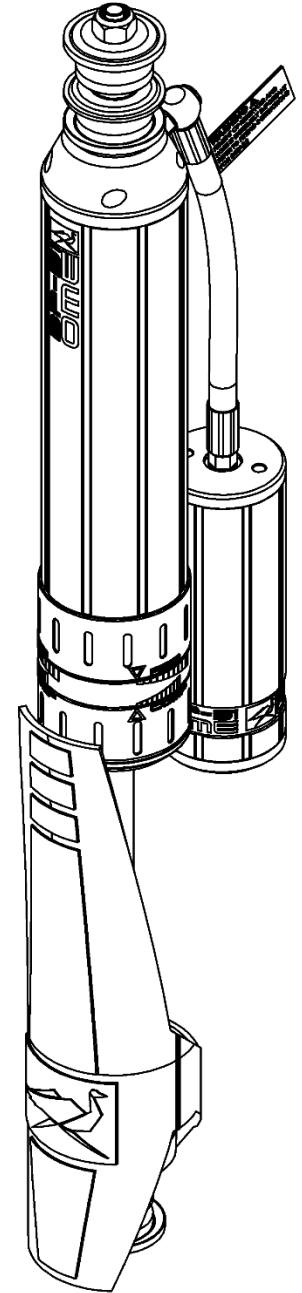

FITTING KIT CONTENTS – VM80010037

Item	Description	Qty	Spare Part No.
1	RESERVOIR CLAMP	2	VE10010003SP
2	M8 X 40MM CUP HEAD/ SQUAR NECK BOLT	4	6151439SP
3	M8 WASHER	44	VE70020004SP
4	M8 NYLOC NUT	24	VD60010004SP
5	M6 NYLOC NUT	4	VD60010003SP
6	M6 WASHSER	4	VE70020005SP
7	M6 X 16MM BOLT	4	VD60030003SP
8	REAR BUMP STOP SPACER	2	3759137SP
9	M8 X 60MM BOLT	4	6151914SP
10	ADJUSTER TOOL	1	VC10010071SP
11	REAR RESI BRACKET 1	2	VE10020033SP
12	REAR RESI BRACKET 2	2	VE10020034SP
13	REAR SHOCK TOP MOUNT RIGHT (SHOWN) REAR SHOCK TOP MOUNT LEFT	1 1	3759128RSP 3759128LSP
14	M10 WASHER	12	4581040SP
15	M10 NYLOC NUT	6	6151322SP
16	M10 X 100MM BOLT	6	6151299SP
17	M8 X 25MM BOLT	16	6151546SP
18	REAR SWAY BAR SPACER	2	3759131SP

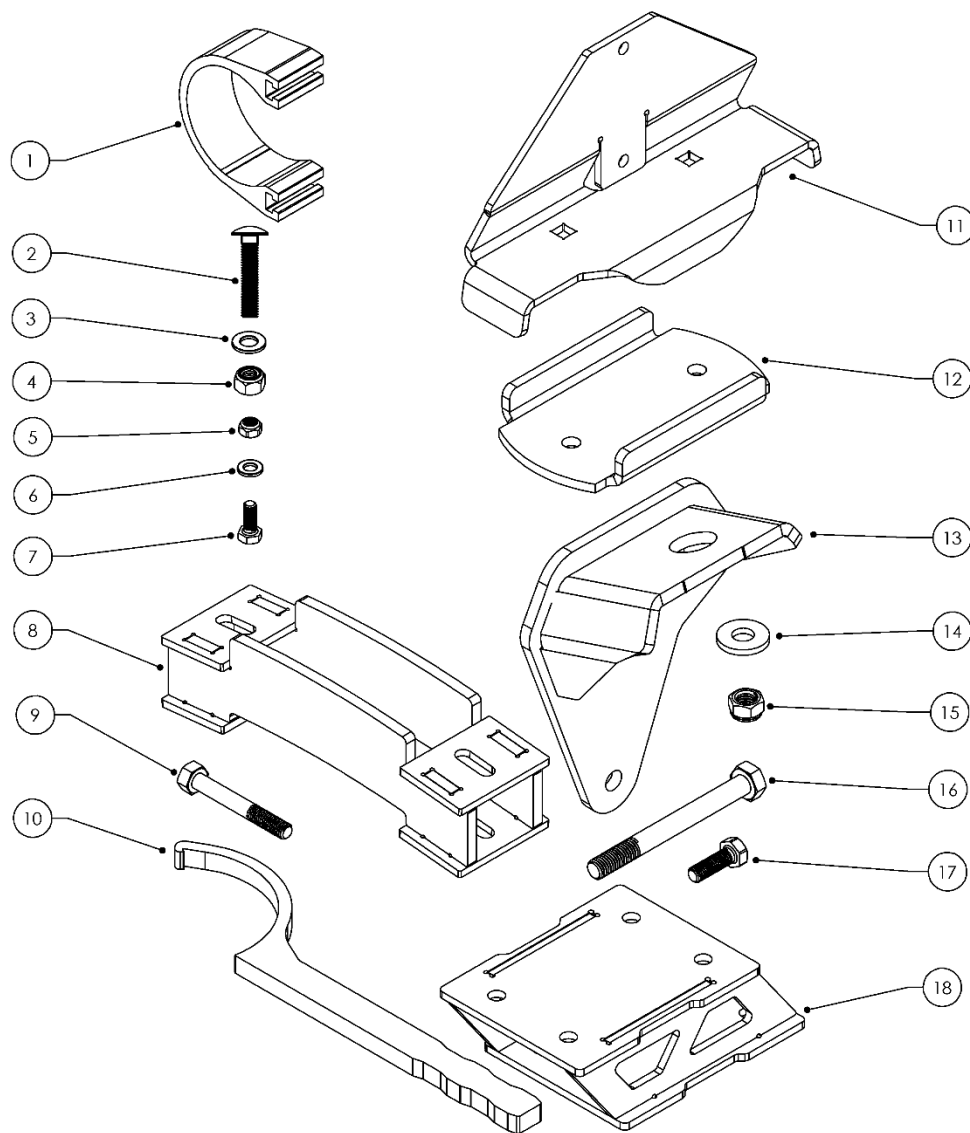

PREPARATION

Remove OE damper and Rear Upper Damper Mount from the chassis as per workshop manual.

Install the new supplied mounting bracket using the supplied M10 X 100 bolts, washers and nut as shown.

Torque to 44 N.m

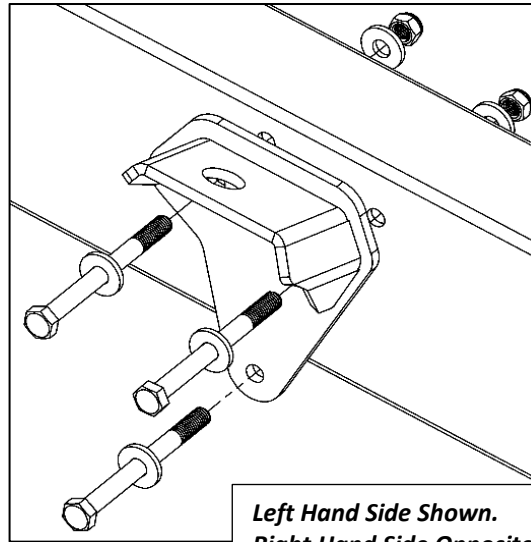

SECURING SHAFT GUARDS

It is easiest to fit the shaft guards before fitting the dampers to the vehicle.

Fit the retaining clips to the shaft guard adaptor as shown in the diagram.

Note the orientation.

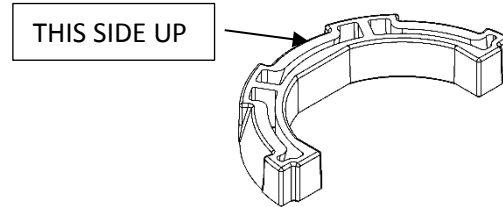

There are features on the shaft guard that locate in the gap between the two retainers.

Align the guard with these gaps and firmly pull the guard down over the retainers to secure in place.

Check retainers are completely secured by guard.

If not secured, use a flat blade screw driver to poke retainer under tab on guard as required.

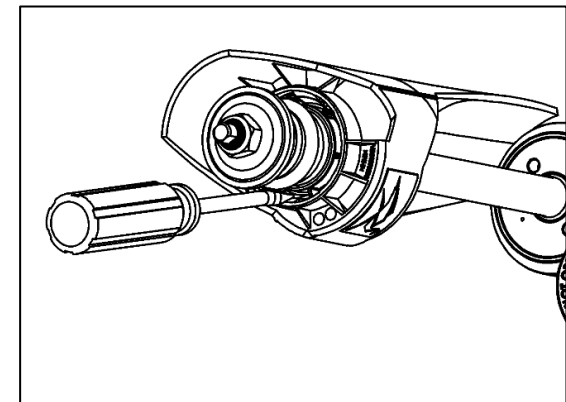
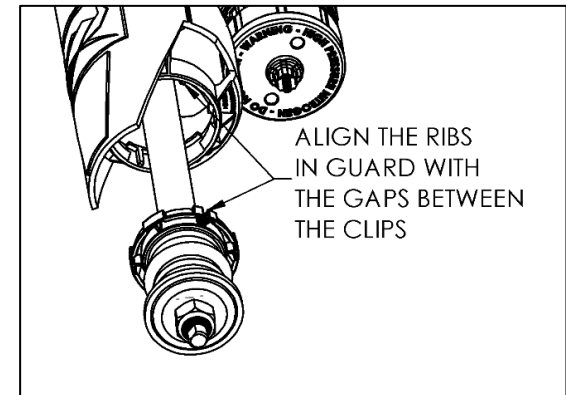
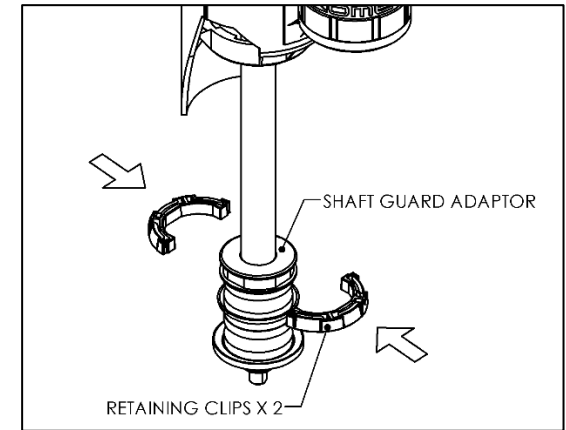

DAMPER MOUNTING

The BP-51 needs to be fitted with the suspension in droop.

Remove nut, retaining washer and bush from top and bottom as shown in the diagram.

1. Fit the damper to the vehicle top mount first.

Ensure the hose leaving the damper is pointing towards the outside of the vehicle as shown in picture 1b.

Fit the bush and retaining washer and secure with the Nyloc nut.

Torque to 70 N.m

2. Fit the damper to the axle mount then fit the bush and retaining washer and secure with the nut as shown.

Torque to 70 Nm.

Note:

For vehicles fitted with locating cups, before fitting the damper remove the cups using a chisel and hammer or drilling the spot welds just enough to remove the cups from the mount.

3. Ensure guard is facing toward the front of the vehicle.

BUSH KIT VM50010005

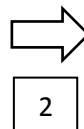
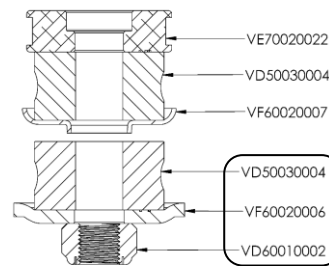
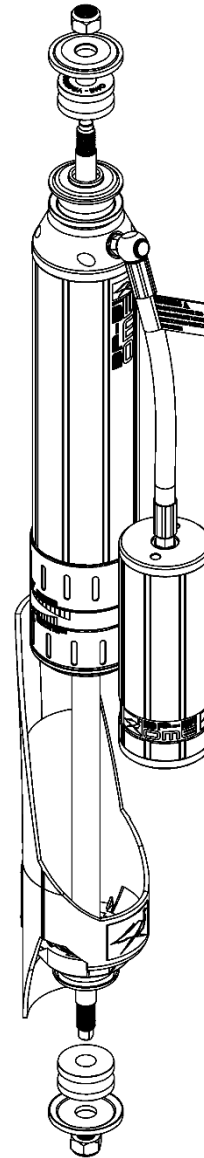
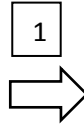
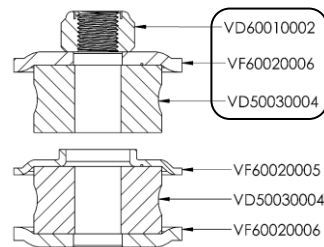

BUSH KIT VM80010024



RESERVOIR MOUNTING SEQUENCE

Left and Right are the same

1. Pre-assemble M6 fasteners to the reservoir bracket finger tight.
2. Fit the preassembled bracket to the vehicle using M8 fasteners as shown.

Torque to 17 N.m

3. Fit the mounting saddle to the reservoir and slide over the heads of the bolts in the mounting plate. Centralise the saddle on the plate and adjust the position of the reservoir as shown.

Ensure the reservoir hose has a clean arc with no kinks. (3a)

Note position of reservoir to saddle as shown by the picture 3b.

Securely tighten M6 nuts.

Torque to 12 N.m

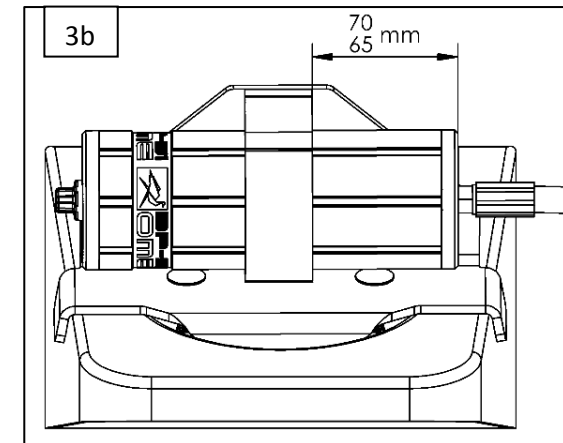
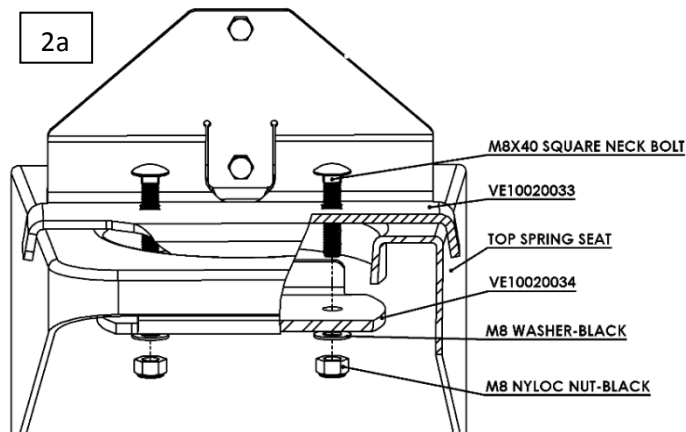
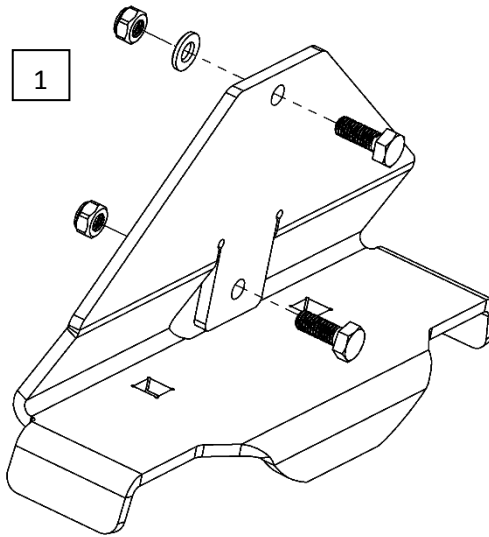

REAR BUMPSTOP SPACER

Remove the rear bump stop.

Install the supplied bump stop bracket between the bump stop and the chassis using the new M8 fasteners as shown in the pictures.

Torque to 12 N.m

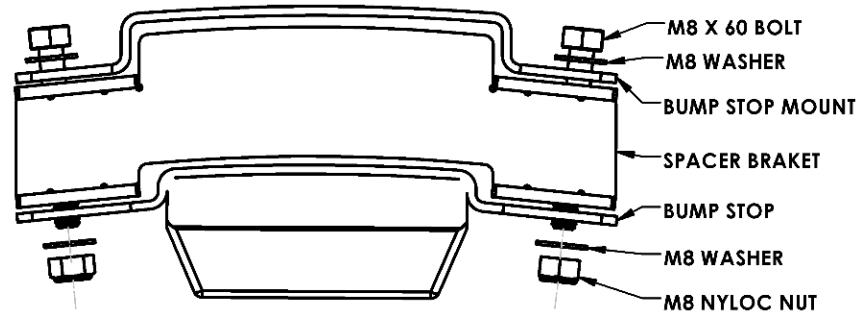

REAR SWAY BAR SPACER

The brackets are designed to move the sway bar position down and forward.

Remove the front sway bar and install the supplied sway bar bracket with the new supplied M8 fasteners as shown.

Raise the sway bar to meet the bracket and install the remaining M8 fasteners as shown.

Torque to 22 N.m

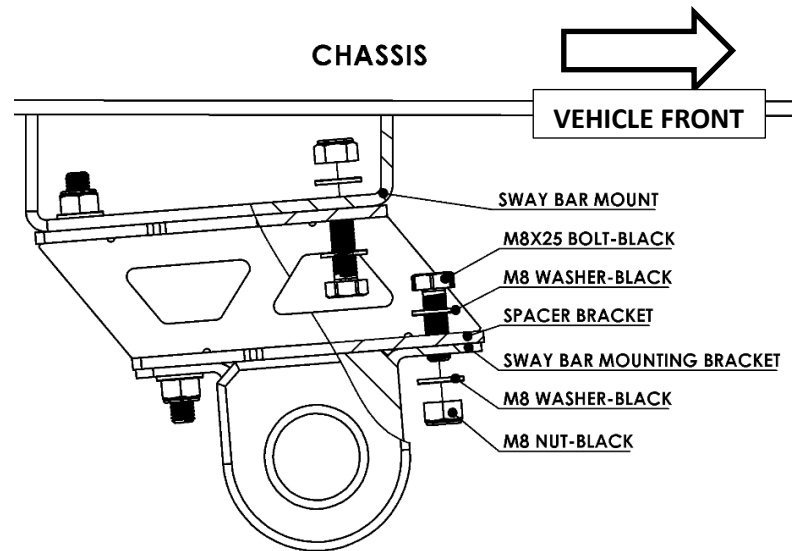

SPECIFICATIONS AND SPARE PARTS

1	Spare Part: Top Bush Kit	VM50010005SP
2	Spare Part: Hose	VD81020225SP
3	Spare Part: Oil	VM80020015
4	Specification: Nitrogen Pressure	2000 kPa
5	Specification: Factory Rebound Setting	0
6	Specification: Factory Compression Setting	3
7	Spare Part: Valve Assy	VM80030001SP
8	Spare Part: Shaft Guard	VD31010260SP
9	Spare Part: Retaining Shaft Guard Yellow	VD31000003SP
10	Spare Part: Lower Bush Kit	VM50010024SP
11	Spare Part: Damper Mounting Kit	VM80010037SP

DAMPING ADJUSTMENT

These dampers have been set in the factory to be used for a vehicle with accessories fitted. If your load or accessory fitment differs, use the table below as a guide for recommended compression (Comp) and rebound (Reb) adjuster settings. Refer to the Owners' Manual for more information.

Rear Load	Comp	Reb
0 - 200 kg	0-4	0-4
200 - 400 kg	2-6	4-8
400 - 600 kg	4-8	6-10

