

# FITTING INSTRUCTIONS

## BP5160032

### JEEP JK WRANGLER 2 INCH LIFT REAR

## WARNING

- ◆ This product must be installed exactly as per these instructions using only the hardware supplied.
- ◆ In the event of damage to any suspension component, contact you're nearest authorised ARB stockist.
- ◆ Repairs or modifications to the suspension system components must not be attempted.
- ◆ Do not use this product for any vehicle make or model, other than those specified by ARB.
- ◆ Do not remove labels from suspension components.
- ◆ This product or its fixing must not be modified in any way.
- ◆ The installation of this product may require the use of specialized tools and/or techniques
- ◆ It is recommended that this product is only installed by trained personnel
- ◆ These instructions are correct as at the publication date. ARB Corporation Ltd. cannot be held responsible for the impact of any changes subsequently made by the vehicle manufacturer
- ◆ During installation, it is the duty of the installer to check correct operation/clearances of all components
- ◆ Work safely at all times

**Note:** These fitting instructions should be read in conjunction with the vehicle workshop manual.

**BP5160032 (2" Lift) requires a rear bump spacer min. 40mm, Use supplied 3757564 spacer bracket (45mm) or FK40 (65mm).**

The stone guard fitted to the rear shock absorbers is designed to protect the shaft from front tyre stone roost. When used in rock crawling terrain the stone guards may become dislodged from the eyelet in the event of heavy rock contact. In this terrain it may be preferable to remove the stone guards.

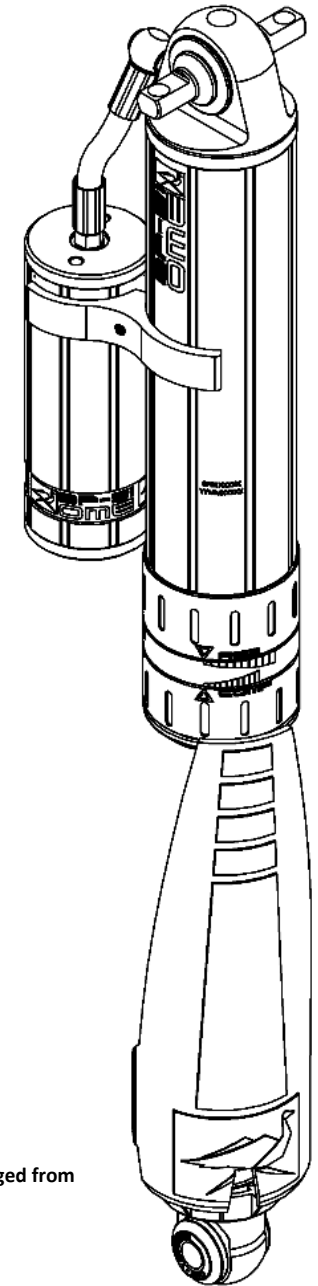

**FITTING KIT CONTENTS – VM80010031**

Item	Description	Qty	Spare Part No.
1	ADJUSTER TOOL	1	VC10010071SP
2	SPACER JEEP JK REAR TOP	2	VE10010012SP
3	M10 WASHER SPRING BLACK	2	4581292SP
4	M10 x 1.5 X 45mm SHCS	2	VD60020009SP
5	BUMP SPACER BRACKET JK 2"	2	3757564SP
6	BOLT M8 x 1.25 x 20	4	6151021
7	NUT M8 FLANGE 1.25	4	6151132
8	WASHER M8 FLAT	4	4581044
9	RESI CLAMP ASSEMBLY	2	VM20010001SP

**SUPPLIED WITH BP-51 DAMPER**

**SHAFT GUARD RETAINERS**

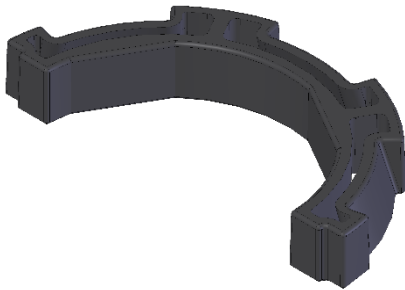

GREY (for RHS)  
(Spare Par No. VD31000004SP)

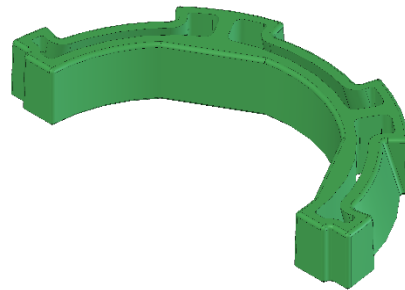

GREEN (for LHS)  
(Spare Part No. VD31000005SP)

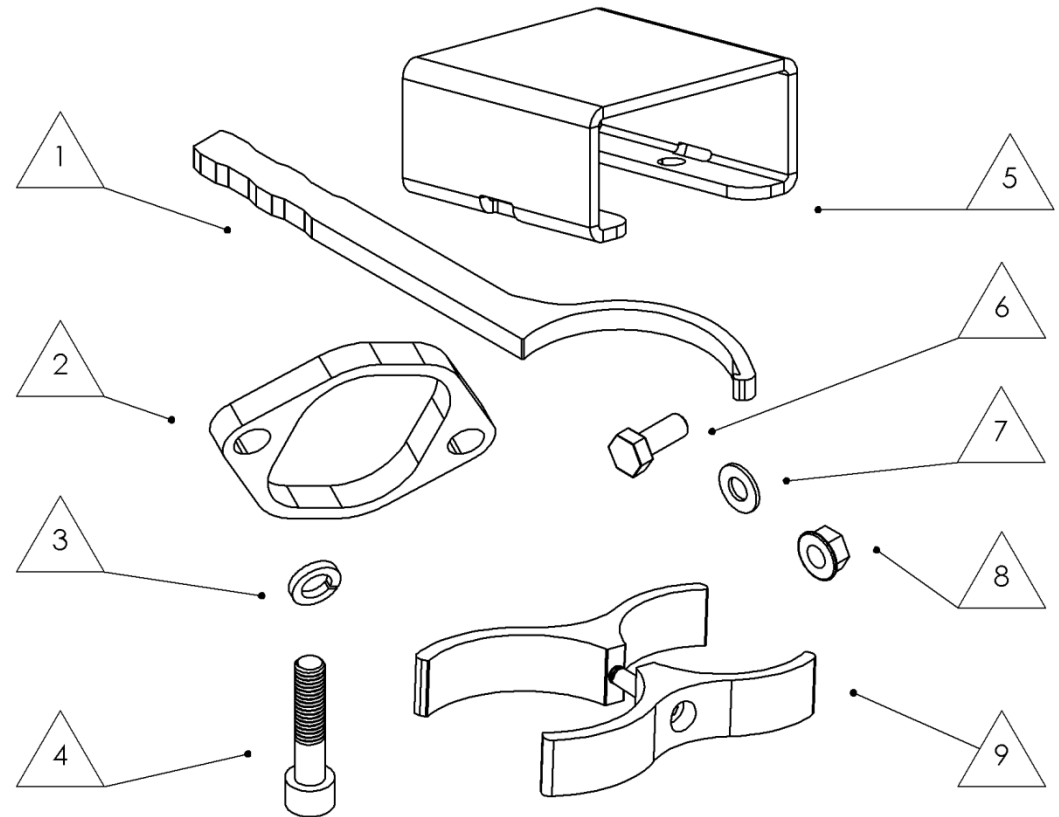

## DAMPER PREPARATION

Before fitment, the Reservoir needs to be clamped to the shock absorber body.

Left and right reservoir positions are mirrored.

Refer to diagrams for orientation.

It is also easiest to secure the shaft guard to the eyelet prior to fitment to the Jeep. Refer to next page for details.

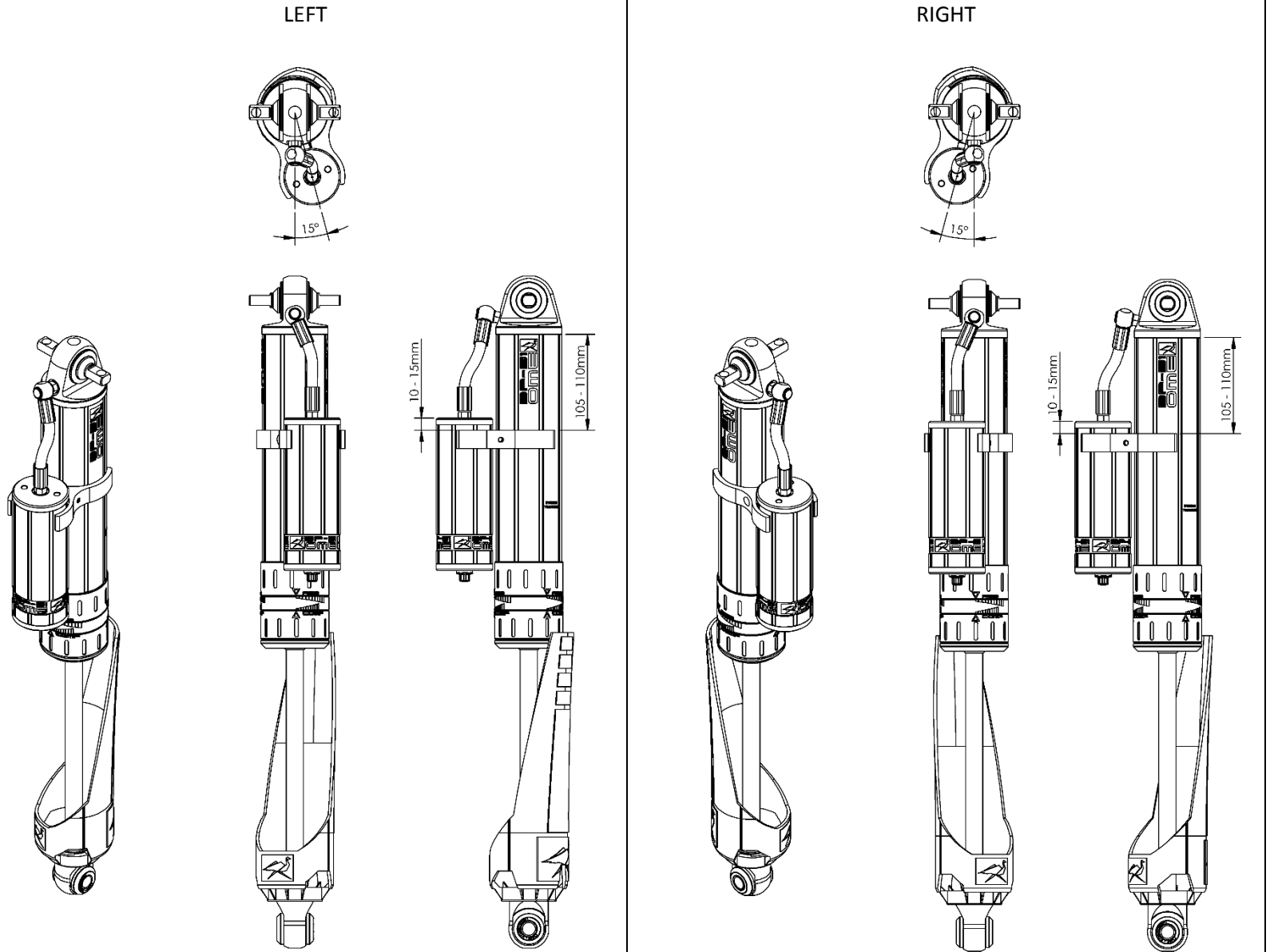

## SECURING SHAFT GUARDS

(RH SHOWN)

The way the shaft guard and retainers are secured is different for left and right hand dampers.

Images shown are right hand side.

It is best to secure the shaft guards before fitting the dampers to the Jeep.

Fit the two retainers to the eyelet as shown.

There are two different retainers to secure the shaft guard.

**Use the grey retainers for the RHS and green retainers for the LHS.**

There are features on the shaft guard that locate in the gap between the two retainers. Align the guard with these gaps such that the cut out in the front of the guard points at an angle forwards and to the centre of the Jeep.

Firmly pull the shaft guard down over the retainers to secure in place.

Check retainers are completely secured by guard. Use a flat blade screwdriver to poke retainer under tab on guard if required.

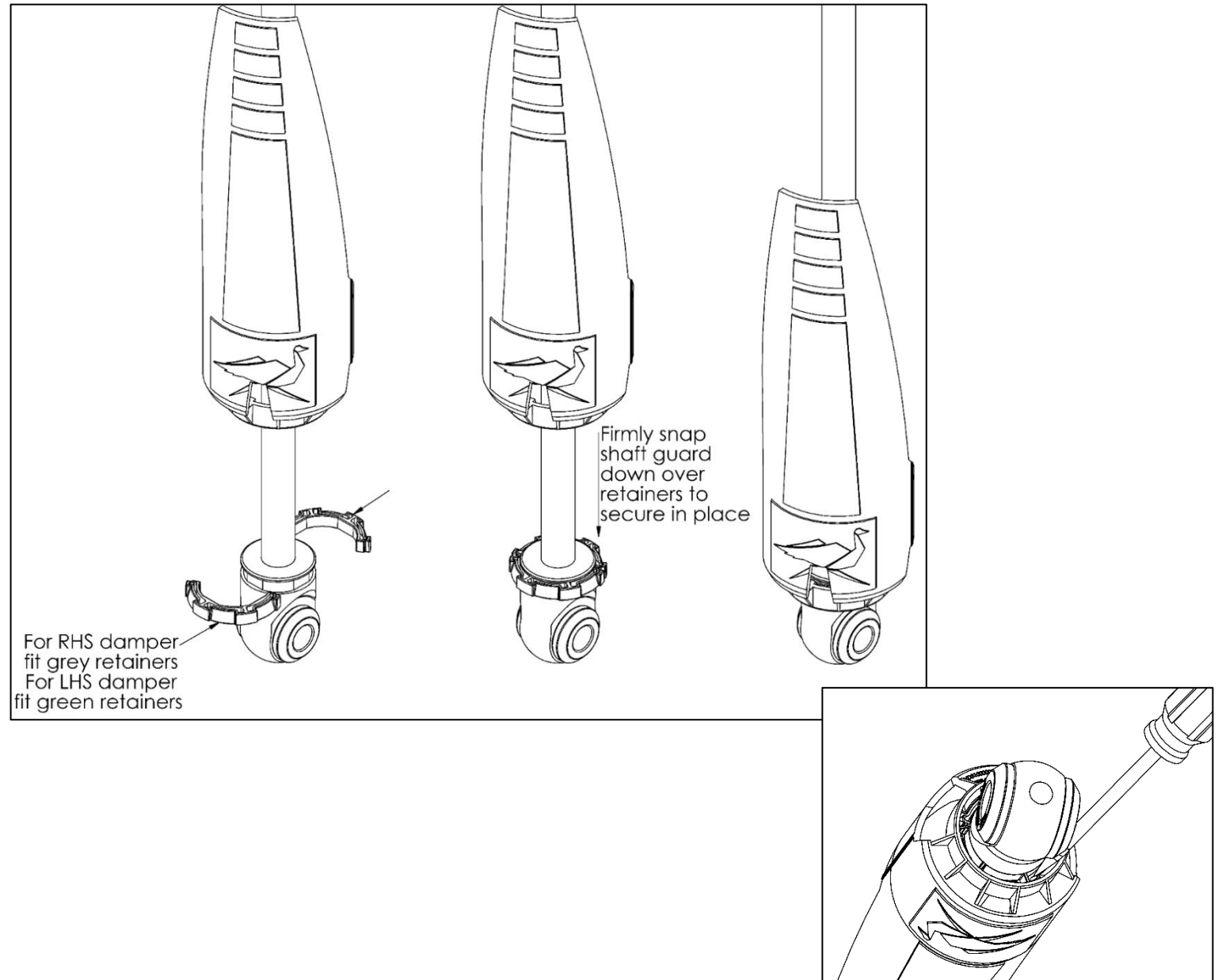

## MOUNTING SEQUENCE

Remove old dampers from vehicle.

The BP-51 needs to be fitted with the suspension in droop.

Mount the BP-51 dampers using the hardware in the sequence as shown in the diagram.

Fit the top mount and droop the wheel to secure the bottom mount.

Ensure the hoses have no kinks and reservoirs are clear of any obstructions such as the rear swaybar or aftermarket panhard brackets.

The shaft guard is designed to protect the shaft from front tyre roost. The open side of the guard should be to the rear so that the shaft is visible from behind the vehicle.

The cut out in the front of the guard is designed to fit around the OE axle mount. This cut out may need modification if fitting to aftermarket axles.

(RH Shown)

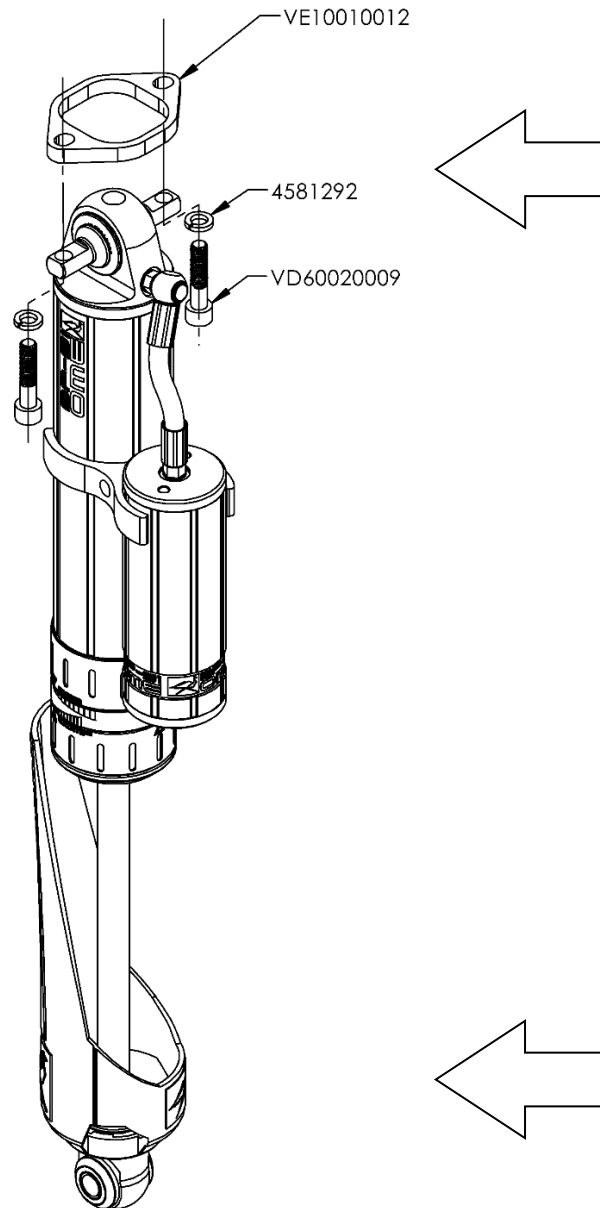

### Top Mount

Fit the damper to the vehicle top mount first. Place the spacer on top and use supplied M10 x 45mm Socket Head Cap Screws (VD60020009) with a Spring Washer to secure as shown by the diagram.

Fit the top mount such that the hose leaving the damper is pointing towards the Rear of the vehicle.



### Bottom Mount

Reuse the OE bolts and nuts to secure the lower mount.

Ensure you locate the cut out on the shaft guard around the OE clevis. The Yellow OME Logo should be facing the rear of the vehicle as shown above.

## REAR BUMP SPACER

Fit M8 x 20 bolts with flat washers to bump stop plate from underside as shown.



Fit bump stop spacer bracket over bolts and secure with flange nuts.

Tip: Secure nuts finger tight and then tighten bolt with spanner from below. Flange nuts will bite into bracket and will not spin.

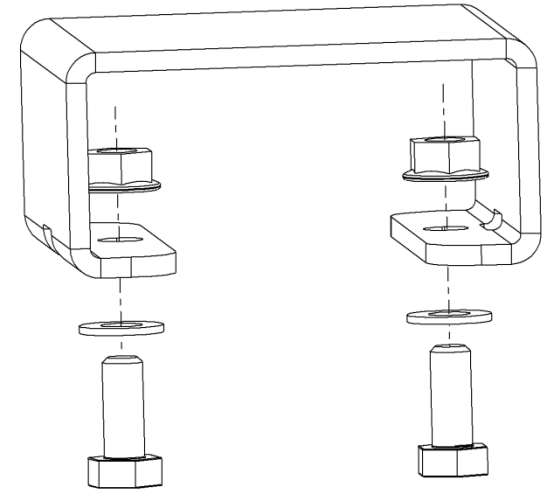



## FINAL CHECKS

Be sure to check clearances once rear shocks are fitted.

- A- Ensure the reservoir hose has 5-10mm of clearance between the hose and the rear sway bar. Adjust the reservoir clamp to suit.

Position the clamp as high as possible on the reservoir and the body as shown.

This clearance ensures no contact between hose and sway bar and also clearance for OME Rear Panhard Bracket kit FK47 as shown in the picture. (Australian spec Right Hand Drive vehicle shown)

- B- Ensure the Banjo Hose Fitting has 5-10mm min. clearance. Remove/grind minimal material from OE Upper mount to provide adequate hose clearance.

- C - Ensure the shaft guards are fitted as shown to protect the Shaft from front tyre roost.

## REAR SHOCK CLEARANCE CHECKS

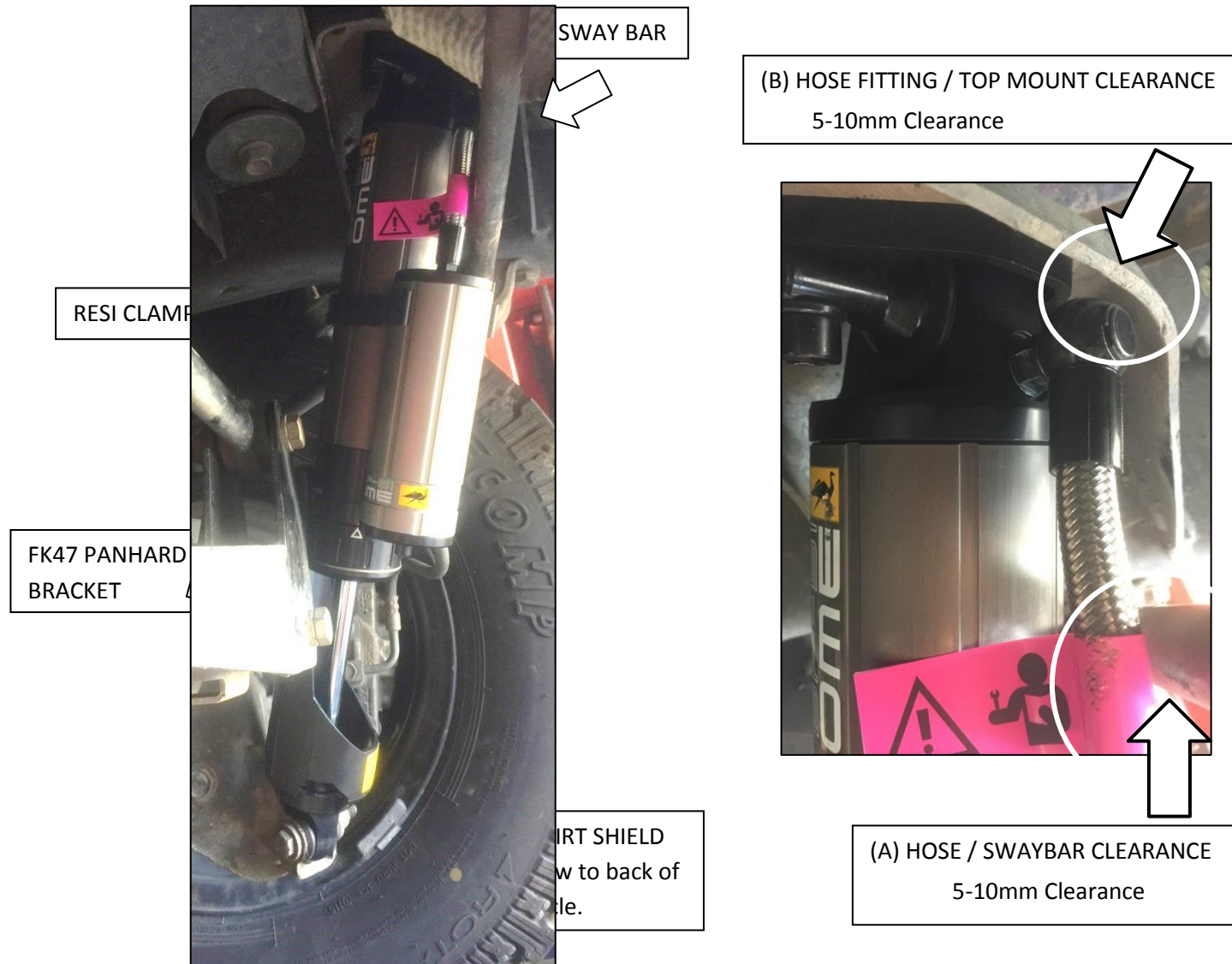

## SPECIFICATIONS AND SPARE PARTS

1	Spare Part: Bush Kit Bar Pin	VM50010009SP		
2	Spare Part: Hose	VD80020090SP		
3	Spare Part: Resi Clamp Assy	VM20010001SP		
4	Spare Part: Oil	VC30040001SP		
5	Specification: Nitrogen Pressure	2000 kPa		
6	Specification: Factory Rebound Setting	5		
7	Specification: Factory Compression Setting	0		
8	Spare Part: Valve Cap	VD30020003SP		
9	Spare Part: Shaft Guard (BP5160032)	VD31030240SP		
10	Spare Part: Shaft Guard Retainer Grey (RHS)	VD3100004SP		
	Spare Part: Shaft Guard Retainer Green (LHS)	VD3100005SP		
11	Spare Part: Bush Kit ID12x40L	VM50010010SP		
12	Spare Part: Damper Mounting Kit	VM800010015		
13	Shock BP5160032	Extended Length 616 mm	Closed Length 393 mm	Shaft Travel 223 mm

## DAMPING ADJUSTMENT

These dampers have been set in the factory to be used for a vehicle with accessories fitted and minimal rear load. If your load or accessory fitment differs, use the table below as a guide for recommended compression (Comp) and rebound (Reb) adjuster settings. Refer to the Owners' Manual for more information.

Rear Load	Comp.	Reb.
0-100kgs (0-200lbs)	0-4	2-6
100-200kgs (200-400lbs)	2-6	4-8
200-300kgs (400-600lbs)	4-8	6-10

