

FITTING INSTRUCTIONS

BP5160025

TOYOTA PRADO 150 / FJ CRUISER REAR

WARNING

- ◆ This product must be installed exactly as per these instructions using only the hardware supplied.
- ◆ In the event of damage to any suspension component, contact your nearest authorised ARB stockist. Repairs or modifications to the suspension system components must not be attempted.
- ◆ Do not use this product for any vehicle make or model, other than those specified by ARB.
- ◆ Do not remove labels from suspension components.
- ◆ This product or its fixing must not be modified in any way.
- ◆ The installation of this product may require the use of specialized tools and/or techniques
- ◆ It is recommended that this product is only installed by trained personnel
- ◆ These instructions are correct as at the publication date. ARB Corporation Ltd. cannot be held responsible for the impact of any changes subsequently made by the vehicle manufacturer
- ◆ During installation, it is the duty of the installer to check correct operation/clearances of all components
- ◆ Work safely at all times

Note: These fitting instructions should be read in conjunction with the vehicle workshop manual.

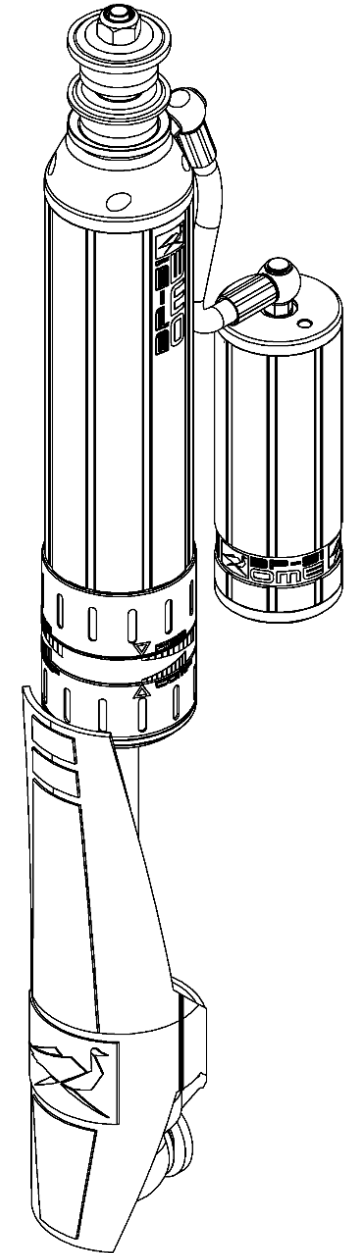

FITTING KIT CONTENTS – VM80010010

| Item | Description | Qty. | Spare Part No. |
|------|--------------------------------|------|----------------|
| 1 | BRKT RESI MOUNT PRADO REAR (R) | 1 | VE10020013SP |
| 2 | RESERVOIR CLAMP | 2 | VE10010003SP |
| 3 | BRKT RESI MOUNT PRADO REAR (L) | 1 | VE10020011SP |
| 4 | BRKT CAGE NUT TWIN M8 220MM | 2 | VE10040006SP |
| 5 | ADJUSTER TOOL | 1 | VC10010071SP |
| 6 | WASHER ID12 OD19 T3 | 2 | VE70020001SP |
| 7 | WASHER ID19 OD46 T5 | 2 | VE70020010SP |
| 8 | NUT M6 NUT NYLOC | 4 | VD60010003SP |
| 9 | WASHER 6mm FLAT BLACK | 4 | VE70020005SP |
| 10 | BOLT M6x1.0x16 | 4 | VD60030003SP |
| 11 | NUT M8 CAGED | 4 | 6151303SP |
| 12 | WASHER SPRING 8mm BLACK | 4 | 4584325SP |
| 13 | WASHER 8mm FLAT BLACK | 4 | VE70020004SP |
| 14 | BOLT M8x1.25x20 | 4 | VD60030001SP |

SUPPLIED WITH BP-51 DAMPER

PIN MOUNT BUSH KIT (Spare Part No. VM50010004SP)

| Item | Description | Qty. | Part No. |
|------|-------------------------|------|------------|
| A | M12 NUT NYLOC | 1 | VD60010002 |
| B | WASHER LOCATING 195002 | 1 | VF60020005 |
| C | WASHER RETAINING 195004 | 2 | VF60020006 |
| D | BUSH NR 143820 | 2 | VD50030004 |

SHAFT GUARD RETAINER (Spare Part No. VD31000003SP)

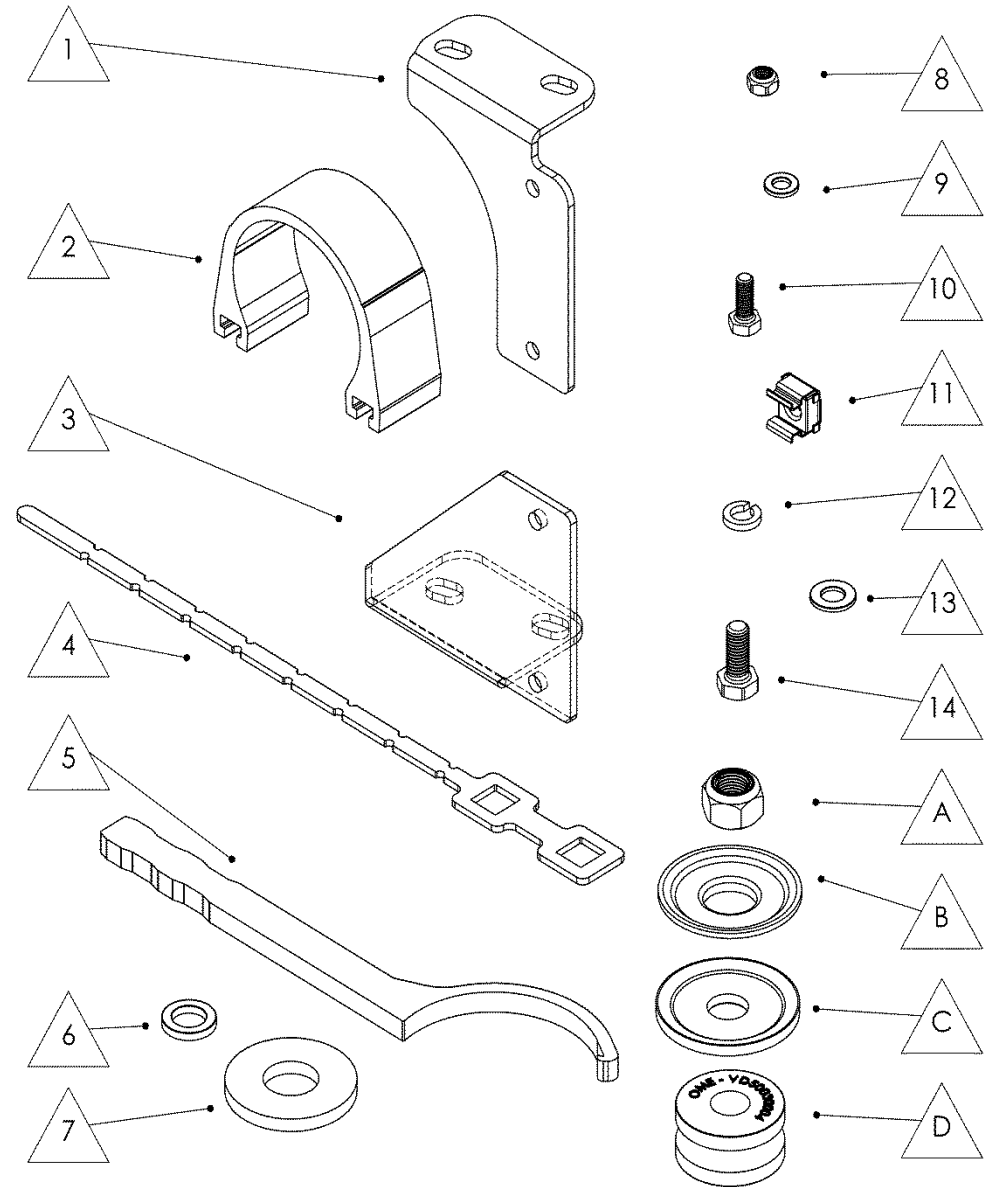
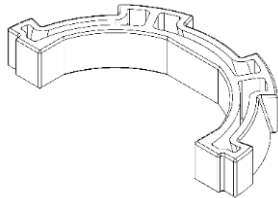

DAMPER PREPARATION

The new BP-51 needs to be prepared with mounting components before it is fitted to the vehicle.

Left and Right are the same.

Refer to the next step for mounting the damper to the vehicle.

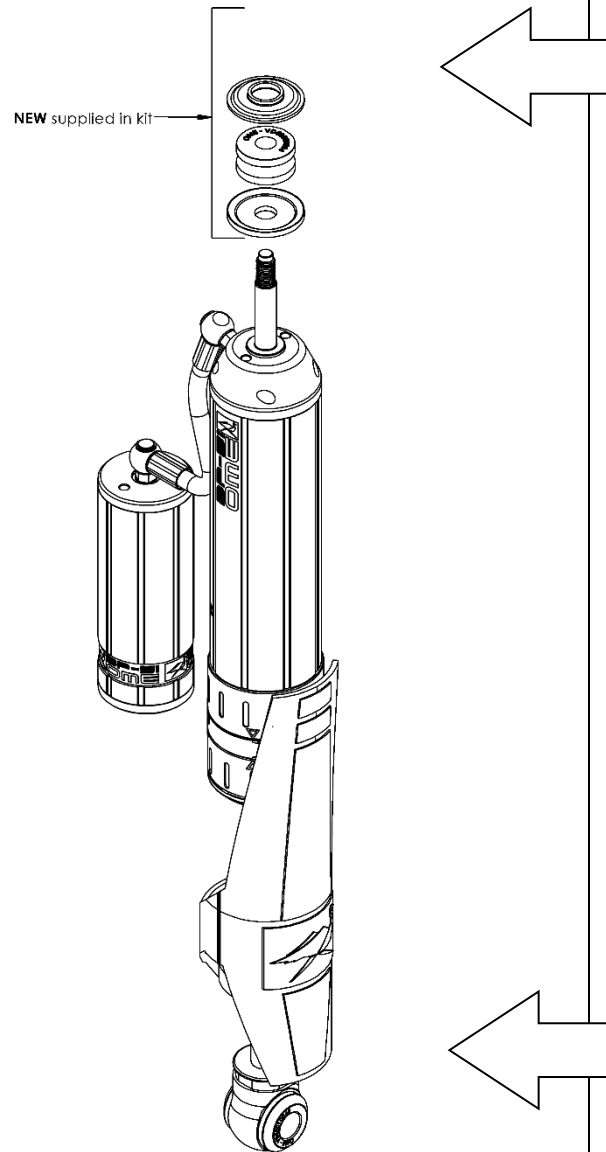

Top Mount

First fit the retaining washer, bush and then locating washer to the pin.

Bottom Mount

Slide the guard and clamp assembly up off the eyelet so that the bottom mount can be accessed.

DAMPER MOUNTING SEQUENCE

The BP-51 needs to be fitted with the suspension in droop.

Before fitting the damper, fit the 5mm washer (VE70020010) to the bottom mount as shown by the diagram.

Mount the BP-51 dampers using the hardware in the sequence as shown, first the top mount then the bottom.

For the bottom mount slide the shaft guard up to access the eyelet. Fasten using original and new hardware as shown then fit the two shaft guard retainers to the eyelet and secure by firmly pulling the guard down over the retainers. Refer to next page for more detail on securing shaft guards.

Ensure all top and bottom mounting hardware is securely fastened.

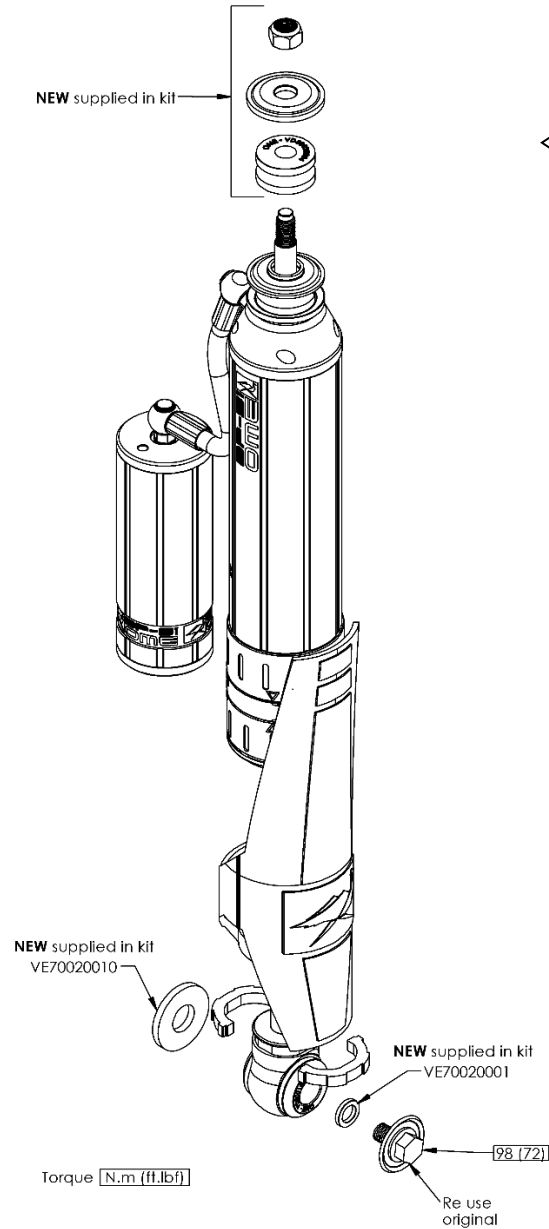

Top Mount

Fit the damper to the vehicle top mount first. Now fit the bush and retaining washer, securing with the nut as shown by the diagram. Leave finger tight and tighten once the bottom eye is mounted and secured.

Fit the top mount such that the hose leaving the damper is pointing outwards into the wheel tub of the vehicle.

Bottom Mount

Ensure the new 5mm flat retaining washer (VE70020010) is in place then slide the guard up, fit the damper and secure with the original and new hardware as shown. Fit the two shaft guard retainers to the eyelet and secure by firmly pulling the guard down over the retainers. Refer to next page for more detail

SECURING SHAFT GUARDS

The shaft guards need to be secured after the dampers are fitted to the vehicle.

Fit the two retainers to the eyelet as shown.

There are features on the shaft guard that locate in the gap between the two retainers. Align the guard with these gaps and firmly pull down over the retainers to secure in place.

Check Retainers are completely secured by guard. Use a flat blade screwdriver to poke retainer under tab on guard if required.

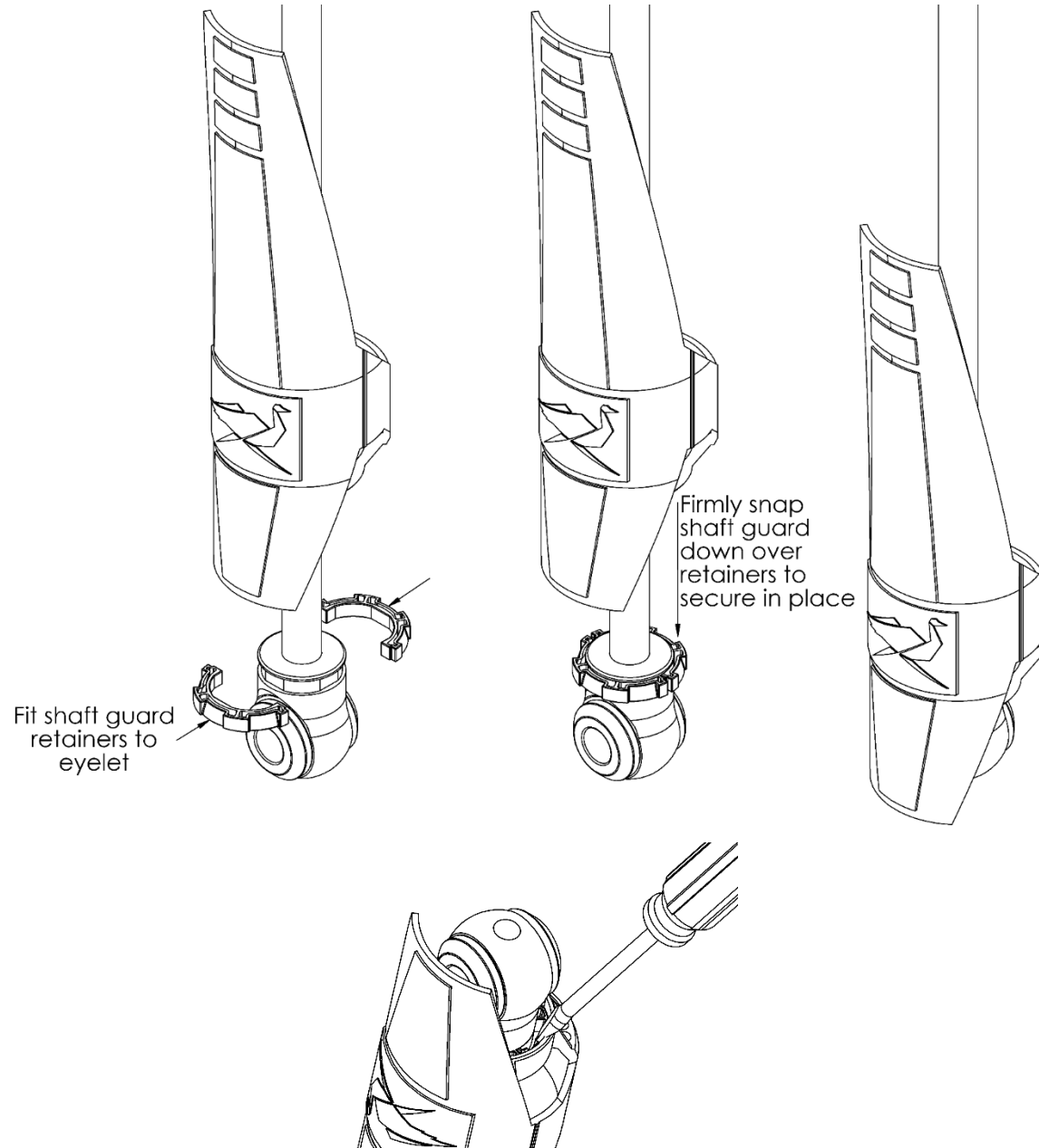

RESERVOIR MOUNTING SEQUENCE

(RIGHT HAND SIDE)

Locate two M8 holes under the chassis behind the damper next to exhaust mount. If vehicle is equipped with HID headlight tilt (shown), there will be a bracket fitted in this location **(1)**.

FJ CRUSIER ONLY:

When fitting to a FJ Cruiser the chassis mount holes are not threaded. **(2)**

Insert M8 cage nuts into cage bracket **(3)** Feed M8 cage nuts + twin cage nut bracket down the inside of the chassis until the holes line up. **(4)**

TIP: Removal of rear coils will improve access to inside hole of chassis.

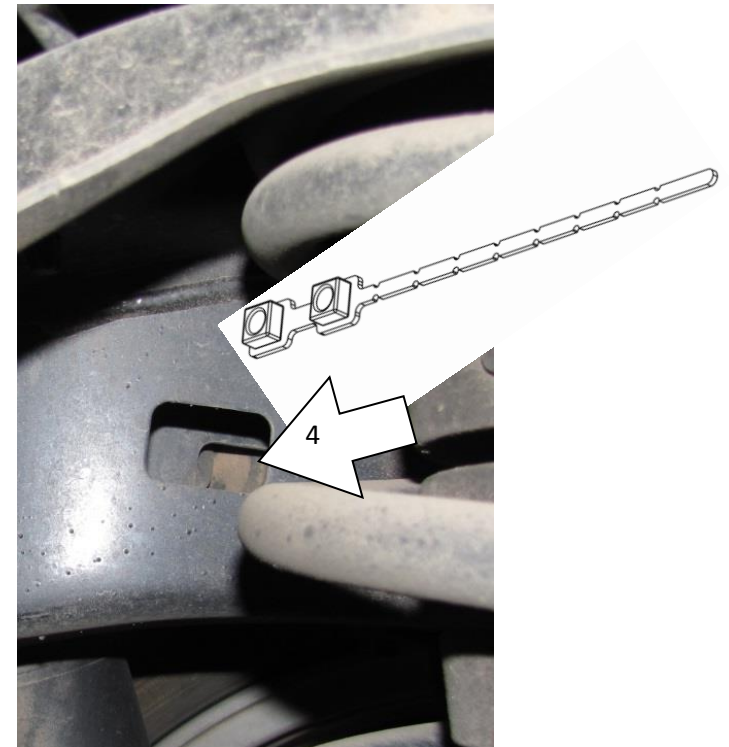
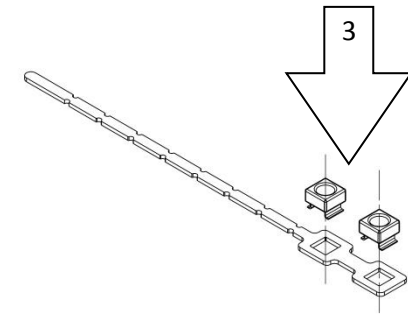
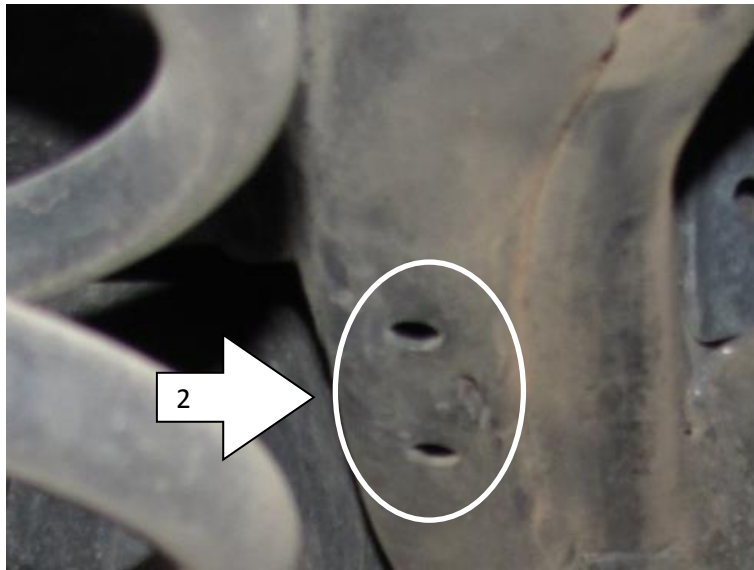
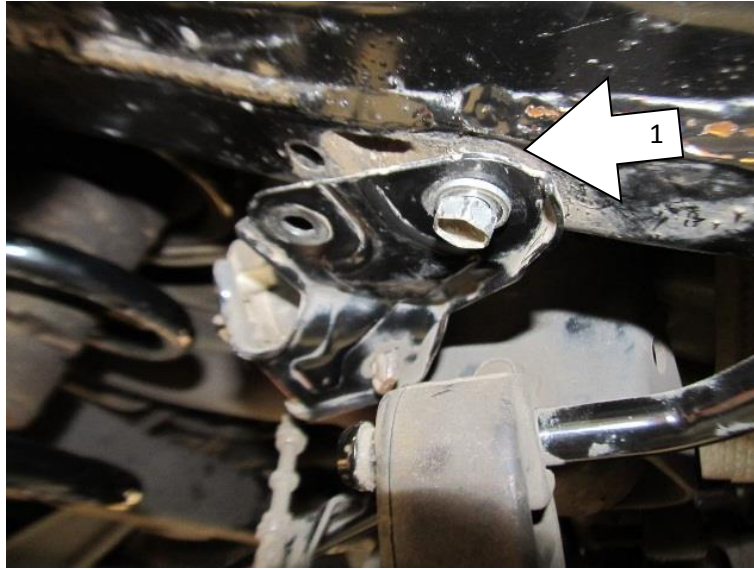

Note: RH reservoir mounting bracket is the one with a curved edge.

Fit M6x 16 bolt, flat washer and nyloc nut to the mounting bracket as shown and secure finger tight only. **(5)**

Fit the reservoir mounting bracket to the chassis using two M8 x 20 bolts, spring washers and flat washers. **(6)**.

(If headlight tilt brackets are fitted fit the reservoir mounting bracket over the top and secure using original bolts).

Torque to 13 N.m (9 ft.lbf).

Fit the reservoir clamp to the reservoir then slide the assembly over the heads of the bolts in the bracket. The edge of the mounting clamp should be parallel with the edge of the bracket **(7)**.

Ensure the reservoir clears the spring and that the hose has a clean arc with no kinks **(8)**.

Note position of reservoir to clamp shown by the photos as a guide. Fasten hardware securely and torque where specified.

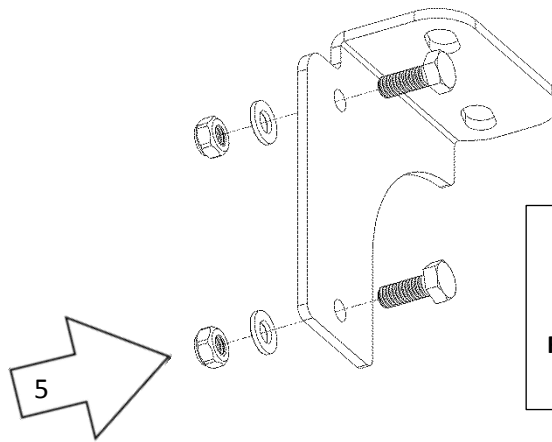

Note:
Brackets are different for RHS and LHS.
RHS shown.

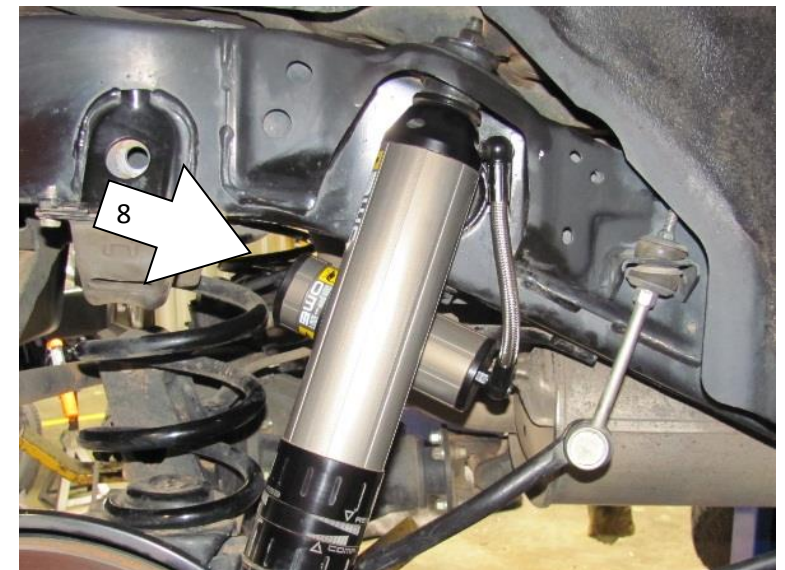

(LEFT HAND SIDE)

LHS fitment as per RHS instructions only now using the LHS Resi Mount Bracket as shown.

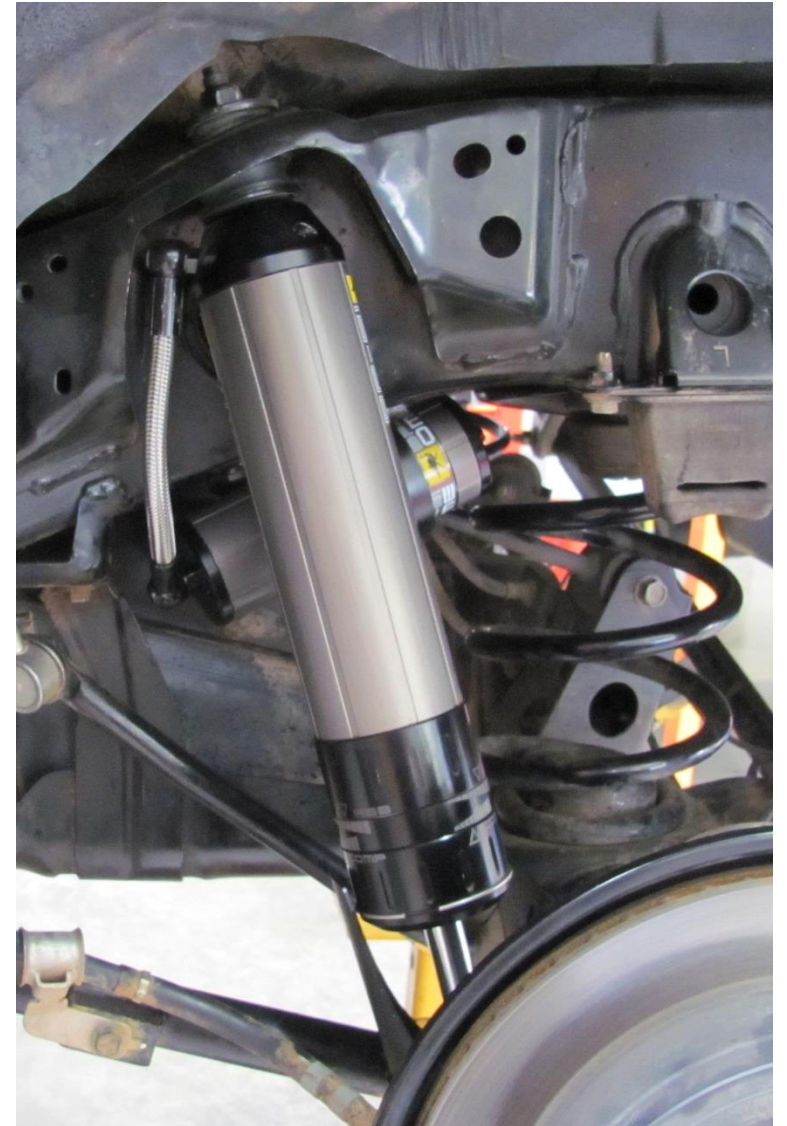
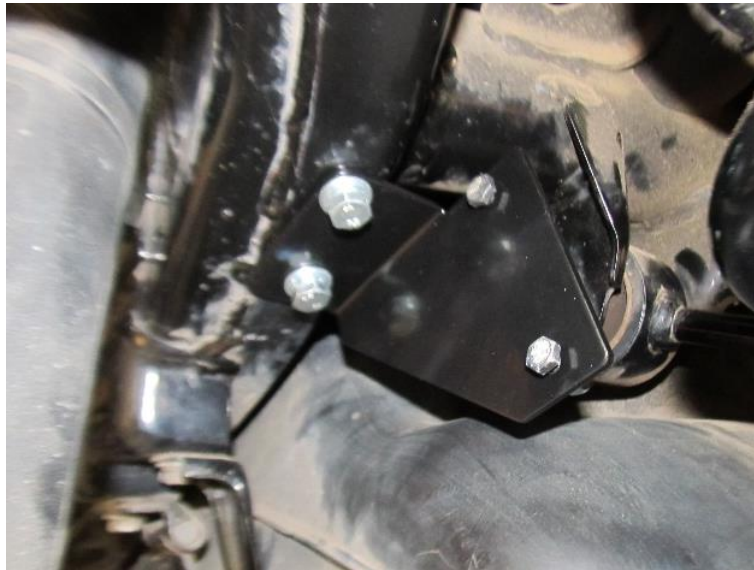
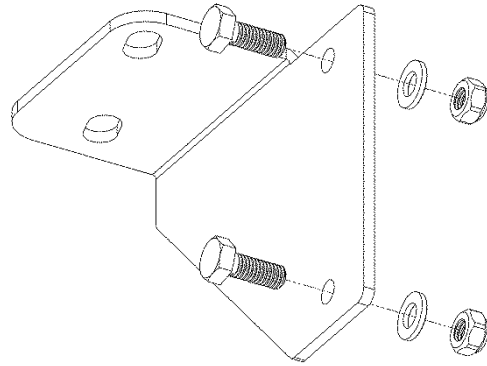

SPECIFICATIONS AND SPARE PARTS

| | | |
|----|--|--------------|
| 1 | Spare Part: Top Bush Kit | VM50010005SP |
| 2 | Spare Part: Hose | VD80031165SP |
| 3 | Spare Part: Oil | VC30040001SP |
| 4 | Specification: Nitrogen Pressure | 2000 kPa |
| 5 | Specification: Factory Rebound Setting | 6 |
| 6 | Specification: Factory Compression Setting | 3 |
| 7 | Spare Part: Valve Cap | VD30020003SP |
| 8 | Spare Part: Shaft Guard | VD31010240SP |
| 9 | Spare Part: Shaft Guard Retainer | VD31000003SP |
| 10 | Spare Part: Bottom Bush | VD50010045SP |
| 11 | Spare Part: Damper Mounting Kit | VM80010010 |

DAMPING ADJUSTMENT

These dampers have been set in the factory for a vehicle with little or no load. If your load or accessory fitment differs, use the table below as a guide for recommended compression (Comp) and rebound (Reb) adjuster settings. Refer to the Owners' Manual for more information.

| Rear Load | Comp | Reb |
|--------------|------|------|
| 0 – 200 kg | 0-4 | 4-8 |
| 200 – 400 kg | 2-6 | 6-10 |
| 400 – 600 kg | 4-8 | 6-10 |

