

FITTING INSTRUCTIONS

BP5160031, BP5160021 & BP5160022

JEEP JK WRANGER FRONT

WARNING

- ◆ This product must be installed exactly as per these instructions using only the hardware supplied.
- ◆ In the event of damage to any suspension component, contact your nearest authorised ARB stockist. Repairs or modifications to the suspension system components must not be attempted.
- ◆ Do not use this product for any vehicle make or model, other than those specified by ARB.
- ◆ Do not remove labels from suspension components.
- ◆ This product or its fixing must not be modified in any way.
- ◆ The installation of this product may require the use of specialized tools and/or techniques
- ◆ It is recommended that this product is only installed by trained personnel
- ◆ These instructions are correct as at the publication date. ARB Corporation Ltd. cannot be held responsible for the impact of any changes subsequently made by the vehicle manufacturer
- ◆ During installation, it is the duty of the installer to check correct operation/clearances of all components
- ◆ Work safely at all times

Note: These fitting instructions should be read in conjunction with the vehicle workshop manual.

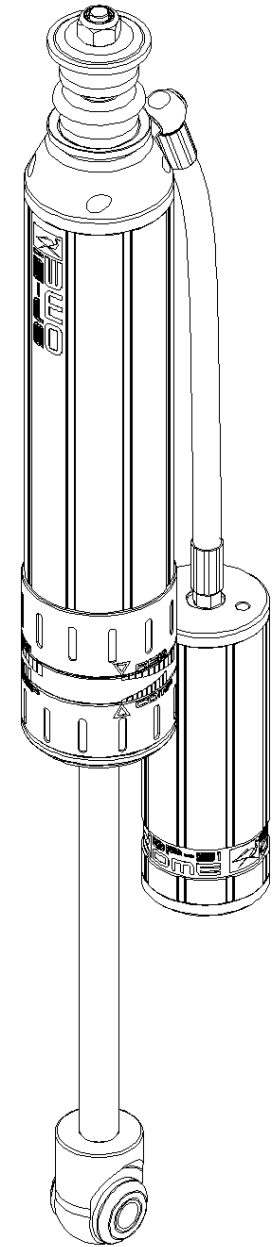

WARNING

BP5160031 is designed to be used with a 2" Lift kit. No Bump Spacing required.

BP5160021 and BP5160022 are designed to suit and work with the OME JK 4" Lift Kit which addresses the following requirements with components as described.

Features	Component	OME Part numbers		Comments
		Front	Rear	
Lift	Springs	2642 / 3047	2643 / 3046	4" lift coils designed to stay located with longer dampers
Damping	Shocks absorbers	60066M / BP5160022	60067 / BP5160023	Dampers with optimised lengths for maximum down travel
Bump Stops	Bump stop spacers	FK40		Bump stops spacers optimised for extended and compressed lengths to allow for maximum compression and rebound control. Minimum Front bump spacer height - BP5160021 50mm (2") - BP5160022 75mm (3")
Castor Correction	Offset washer	FK53		Rectangular washers return factory caster angle
Centre Front Axle	Adjustable panhard rod	PANRJK002	-	Heavy Duty Adjustable front panhard rod to fine tune axle centre location
Centre Rear Axle	Track bar relocation bracket	-	FK47 (LHD/RHD)	Rear track bar bracket centres axle and repositions rear roll centre to provide positive rear stability.
Brake lines	Relocation brackets	FK46		Brake line relocation brackets reroute factory brake lines to work with this kits extended dampers.
Handbrake Cable	Relocation bracket			Handbrake relocation bracket lowers brake line mounting position to relieve stress on brake lines resulting from higher ride height.
Roll Control / Articulation	Extended disconnect sway bar links	FK48		New longer sway bar links to correct sway bar alignment and ensure droop travel is limited by the dampers. Front Link can also be disconnected for increased front axle articulation
Front end wobble	Steering damper & bracket	OMESD48	-	Steering damper with increased control for JK

If not using the complete OME 4" kit please ensure all the above features are considered.

**FITTING KIT CONTENTS
VM80010014**

Item	Description	Qty	Spare Part No.
1	TOOL: ADJUSTER TOOL	1	VC10010071SP
2	RESI MOUNT: JEEP FRONT (part 1)	2	VE10020002SP
3	RESI MOUNT: JEEP FRONT (part 2)	2	VE10020003SP
4	MOUNT: RESERVOIR CLAMP	2	VE10010003SP
5	MOUNT: JEEP FRONT LOWER (L)	1	VF60050004LSP
	MOUNT: JEEP FRONT LOWER (R)	1	VF60050004RSP
6	SLEEVE (16MM OD) 12 x 40	2	VF50021240SP
7	M6 NYLOCK NUT	4	VD60010003SP
8	M6 WASHER BLACK	4	VE70020005SP
9	M6 x 1.0 x 16 BOLT	2	VD60030003SP
10	M6 x 1.0 x 25 BOLT	2	6151550SP
11	M8 NYLOCK NUT	8	VD60010004SP
12	M8 WASHER BLACK	16	VE70020004SP
13	M8 x 1.25 x 20 BOLT	8	VD60030001SP
14	M12 NYLOCK NUT	4	VD60010002SP
15	M12 WASHER OD28 T3	6	VE70020007SP
16	M12 X 1.25 X 80 SCREW BUTTON HEAD	2	VD60020011SP
17	M12 x 1.25 x 70 BOLT	2	VD60030007SP

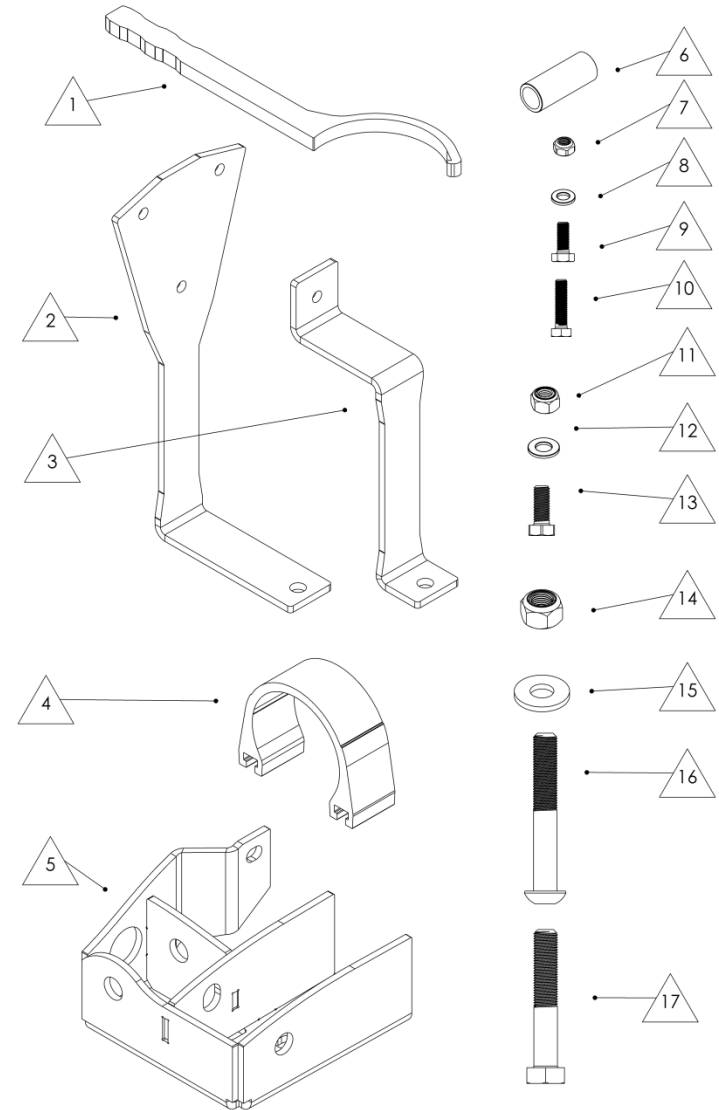

Remove existing Shock absorbers and fit as described.

Lower Shock Mount:

Step 1 – Mount VF60050004L/R using M12 x 80mm Screw , Sleeve as a crush tube, M12 washer and nut to loosely fasten.

Step 2 – Fix in three places M8 bolts nuts and washers.
Torque M8 bolts to 25Nm.
Torque M12 bolt to 60Nm. (step1)

Step 3 – Repeat for opposite side.

Step 1. (LHS shown)

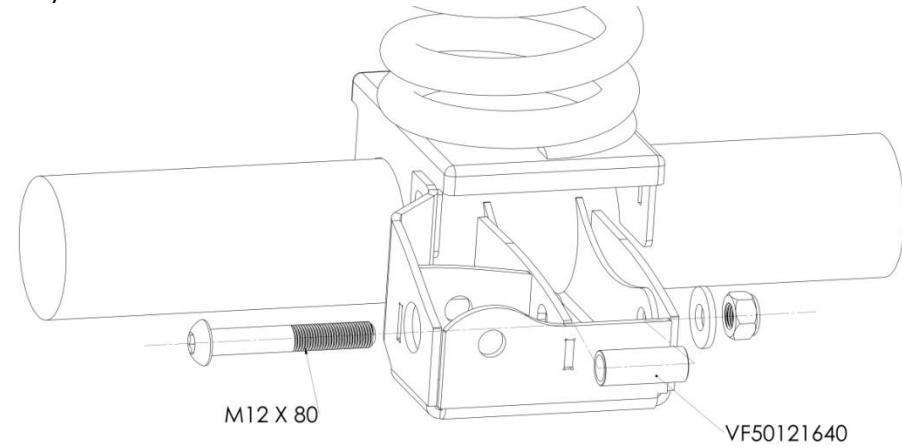

Step 2. (LHS Shown)

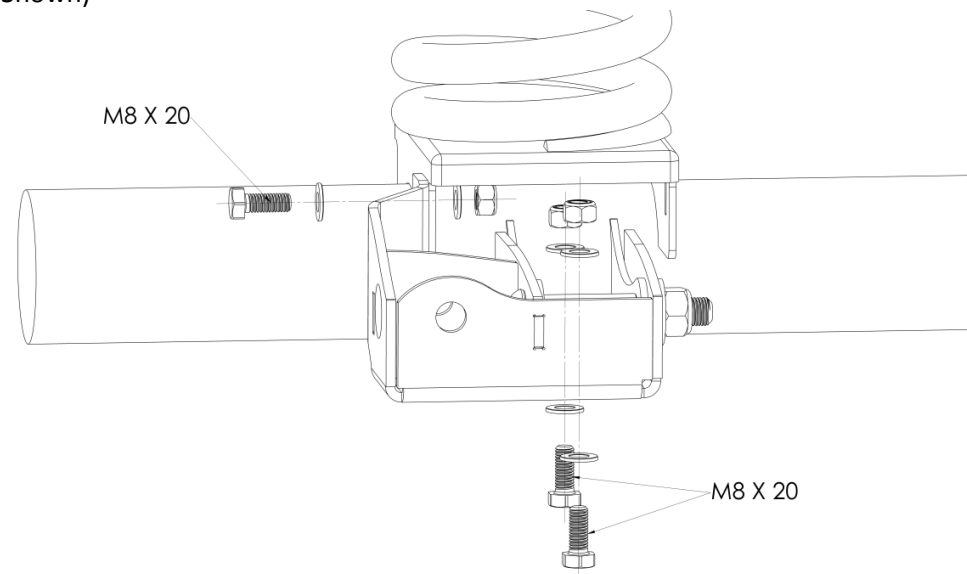

DAMPER MOUNTING SEQUENCE

The BP-51 needs to be fitted with the suspension in droop. Front sway bar and diff breather can be removed to gain more droop.

Mount the BP-51 dampers using the hardware in the sequence as shown.

Ensure all top and bottom mounting hardware is securely fastened.

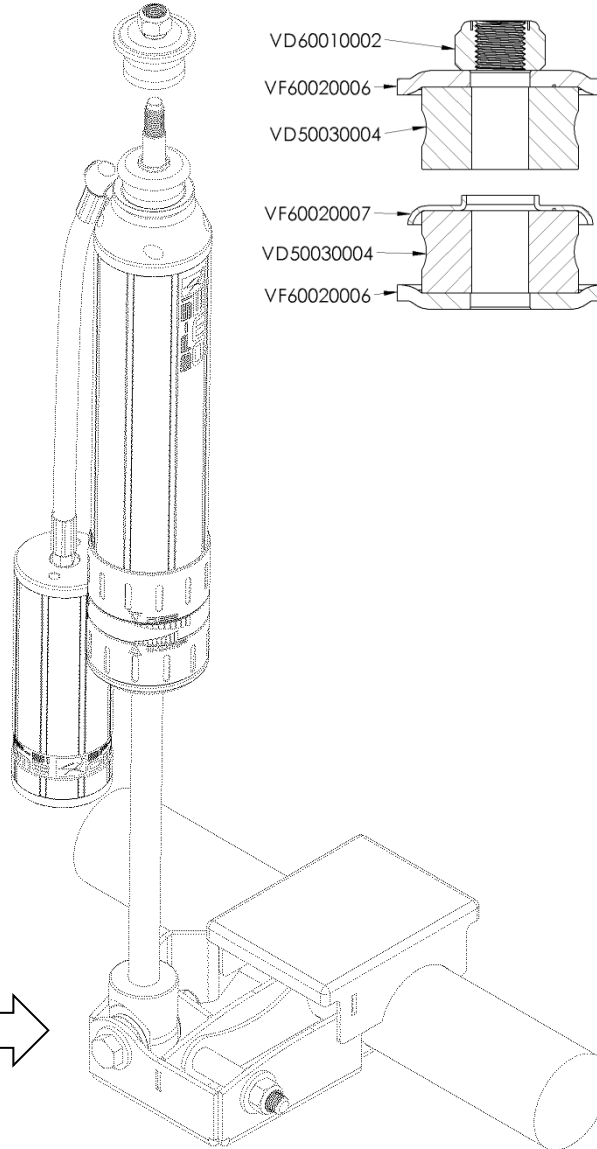

Top Mount

The top mount should be fitted first. Fit retaining washer (VF60020006), Bush (VD50030004) and then Location washer (VF60020007). Insert damper into vehicle mount as shown. Fit bush (VD50030004), retaining washer (VF60020006) and secure nyloc nut. The nyloc nut should be firmly secured against the retaining washer. Fit the top mount such that the hose leaving the damper is pointing towards the outside of the vehicle.

Bottom Mount

Fit the damper into the new lower mount using supplied M12 x 70mm, M12 washers and M12 nyloc nut and secure as shown.

Torque M12 to 60Nm.

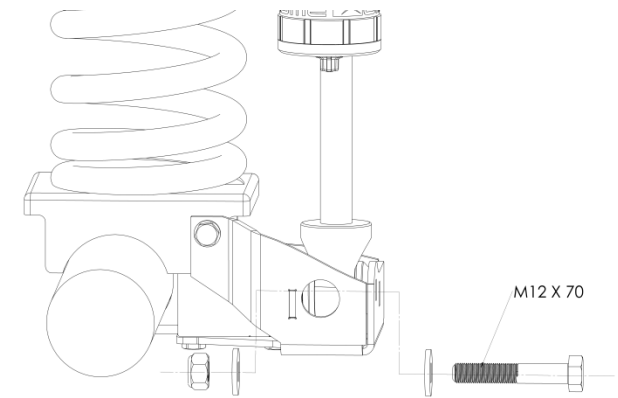

RESERVOIR MOUNTING SEQUENCE

Fit mounting brackets around the chassis rail using M6 x 25 and M8 x 20 as shown in picture loosely.

Trim the wheel arch plastic to create clearance for the resi as shown in far right picture.

Fit M6 x 16 loosely into front mounting bracket using the hole as shown and secure with nyloc nut and flat washer.

Secure finger tight only at this stage.

Fit the mounting saddle to the reservoir and slide over the heads of the bolts in the mounting plate. Adjust the position of the reservoir as shown tilting downwards towards the front of the vehicle and tighten M6 and M8 fasteners.

Ensure the reservoir clears the vehicle body and that the hose has a clean arc with no kinks. You can lightly twist the resi to direct the hose path as required.

Note position of reservoir to clamp shown by the photos as a guide. Fasten hardware securely and torque where specified.

(LHS SHOWN)

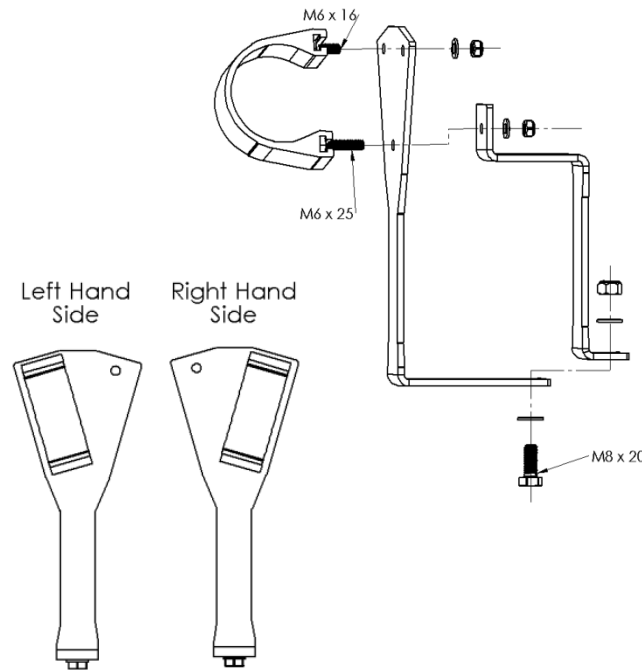

Trim the Wheel Arch plastic as shown below to make clearance for resi.

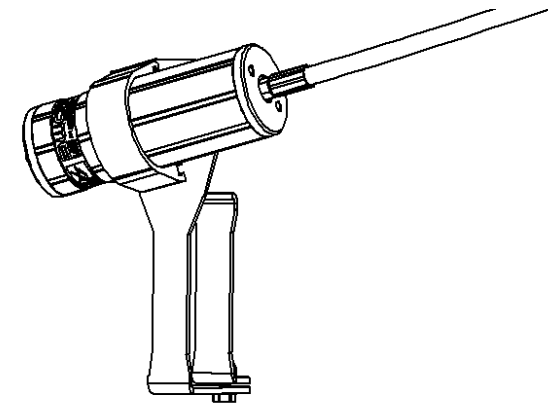

SPECIFICATIONS AND SPARE PARTS

1	Spare Part: Top Bush Kit	VM50010008SP
2	Spare Part: Hose	VD80020275SP
3	Spare Part: Oil	VC30040001SP
4	Specification: Nitrogen Pressure	2000 kPa
5	Specification: Factory Rebound Setting	5
6	Specification: Factory Compression Setting	5
7	Spare Part: Valve Cap	VD30020003SP
8	Spare Part: Bush Kit ID12x40L	VM50010010SP
9	Spare Part: Damper Mounting Kit	VM8000100014

Shock	Extended Length	Closed Length	Shaft Travel
10 BP5160031	578 mm	370 mm	208 mm
BP5160021	628 mm	395 mm	233 mm
BP5160022	678 mm	420 mm	257 mm

DAMPING ADJUSTMENT

These dampers have been set in the factory to be used for a vehicle with accessories fitted. If your load or accessory fitment differs, use the table below as a guide for recommended compression (Comp) and rebound (Reb) adjuster settings. Refer to the Owners' Manual for more information.

Front accessories	Comp	Reb
Bar & winch	4-8	4-8
Bar only	2-6	2-6
No accessories	0-4	0-4

