

FITTING INSTRUCTIONS

BP5160020L & BP5160020R

TOYOTA TUNDRA REAR

WARNING

- ◆ This product must be installed exactly as per these instructions using only the hardware supplied.
- ◆ In the event of damage to any suspension component, contact you're nearest authorised ARB stockist. Repairs or modifications to the suspension system components must not be attempted.
- ◆ Do not use this product for any vehicle make or model, other than those specified by ARB.
- ◆ Do not remove labels from suspension components.
- ◆ This product or its fixing must not be modified in any way.
- ◆ The installation of this product may require the use of specialized tools and/or techniques
- ◆ It is recommended that this product is only installed by trained personnel
- ◆ These instructions are correct as at the publication date. ARB Corporation Ltd. cannot be held responsible for the impact of any changes subsequently made by the vehicle manufacturer
- ◆ During installation, it is the duty of the installer to check correct operation/clearances of all components
- ◆ Work safely at all times

Note: These fitting instructions should be read in conjunction with the vehicle workshop manual.

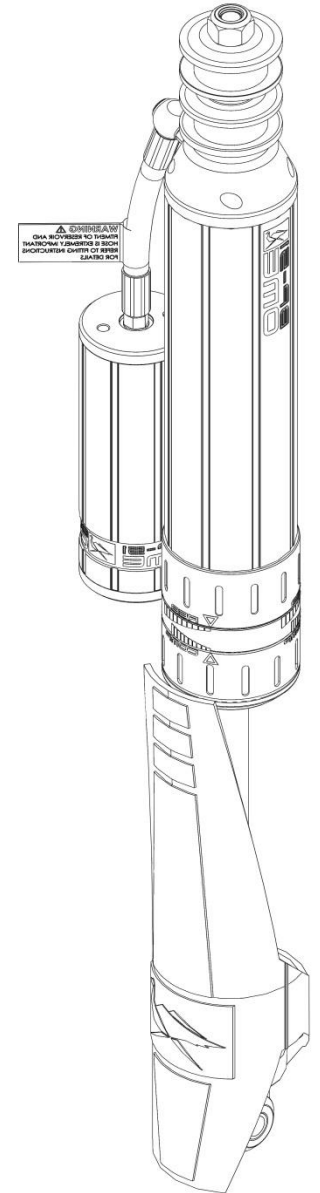

FITTING KIT CONTENTS – VM80010035

Item	Description	Qty	Spare Part No.
1	MOUNT: RESERVOIR CLAMP	2	VE10010003SP
2	TOOL: ADJUSTER TOOL – ASSY	1	VC10010071SP
3	BOLT M8 X 1.25 X 25	4	6151546SP
4	WASHER FLAT M8	8	VE70020004SP
5	WASHER SPRING M8	4	4584325SP
6	NUT NYLOC M8	4	6151547SP
7	RESI MOUNT TUNDRA REAR	2	VE10020028SP
8	M6 x 1.0 X 16 BOLT	4	VD60030003SP
9	M6 WASHER FLAT BLACK	4	VE70020005SP
10	M6 NYLOC NUT	4	VD60010003SP

PIN MOUNT BUSH KIT CONTENTS – VM50010006SP

(Supplied fitted to BP-51 damper)

Item	Description	Qty	Part No.
A	M14 x 1.5 NYLOC NUT	1	VD60010007
B	WASHER LOCATING 215603	2	VF60020002
C	WASHER RETAINING 175604	2	VF60020004
D	BUSH NR 174020	2	VD50030003
E	WASHER ID17 OD32 T5	1	VE70020013

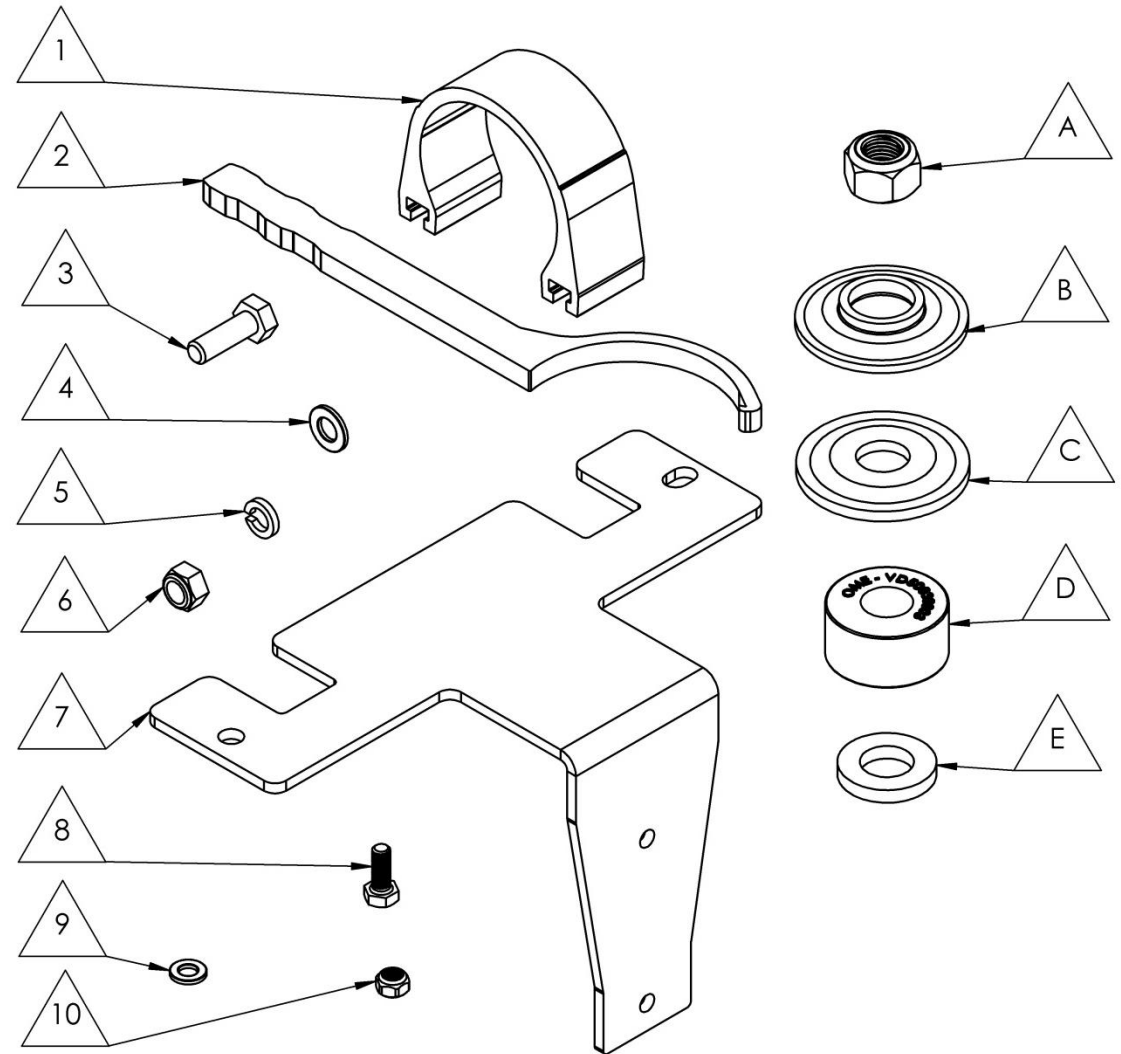

SECURING SHAFT GUARDS (LEFT SHOWN)

It's easiest to secure the shaft guards before the dampers are fitted to the vehicle.

The shaft guards are designed to protect the shaft from front tire roost. Fit the longer guard, that protects the eyelet, to the right (passenger side) damper that mounts to the front of the axle. Fit the shorter guard to the driver's side damper that mounts behind the axle.

Fit the two retainers to the eyelet as shown right.

There are features on the shaft guard that locate in the gap between the two retainers. Align the guard with these gaps and firmly pull down over the retainers to secure in place.

Check the retainers are completely secured by the guard. Use a flat blade screwdriver to poke the retainers under the tabs on the guard if required.

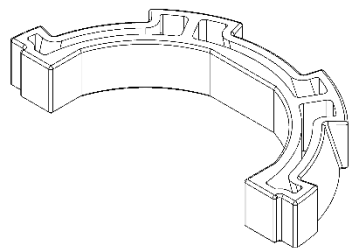

Retainer spare part number
VD3100003SP

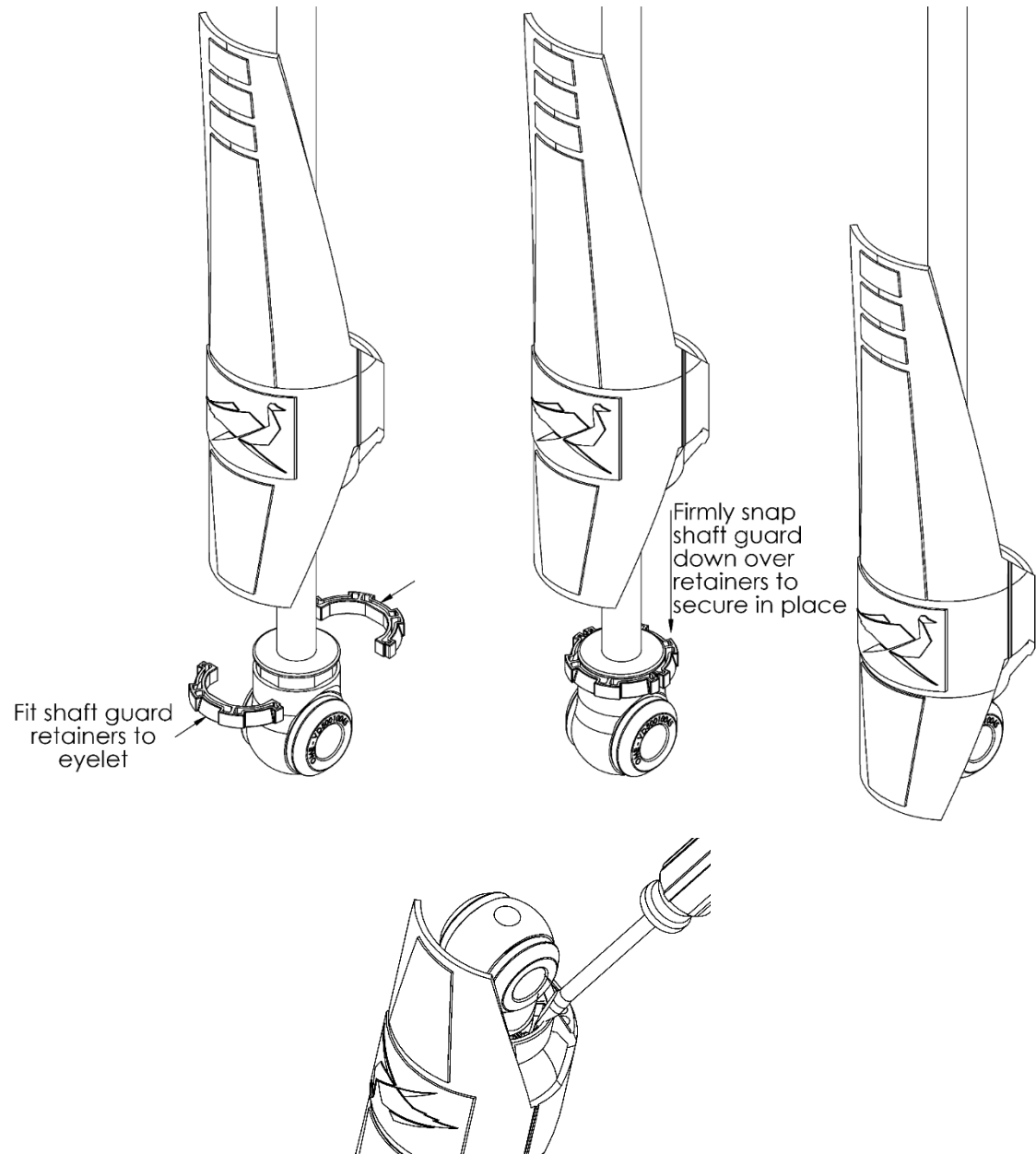

DAMPER MOUNTING

The left is mounted in front of the axle, the right is mounted behind the axle, ensure the guard is on the front side of the damper to protect the shaft from front tire roost.

The BP-51 needs to be fitted with the suspension in droop.

Top Mount

Fit the damper to the vehicle top mount first as described below. Remove the nut, top washer, top rubber bush and locating washer. Fit such that the hose fitting is pointing towards the outside of the vehicle. Insert shock into top mount, then fit Locating Washer (VF60020002), then Bush (VD50030003), Washer (VF60020006) and secure with M14 nut (VD60010007) as shown by the diagram. To hold the damper body still while tightening the top nut place a Phillips head screwdriver into one of the holes adjacent to the hose fitting.

Torque to 108 Nm (80 ft.lbf).

Lower Mount

Fit the lower eye of the shock into the lower mount using OE bolt, washers and nuts.

Torque to 108 Nm (80 ft.lbf).

LEFT

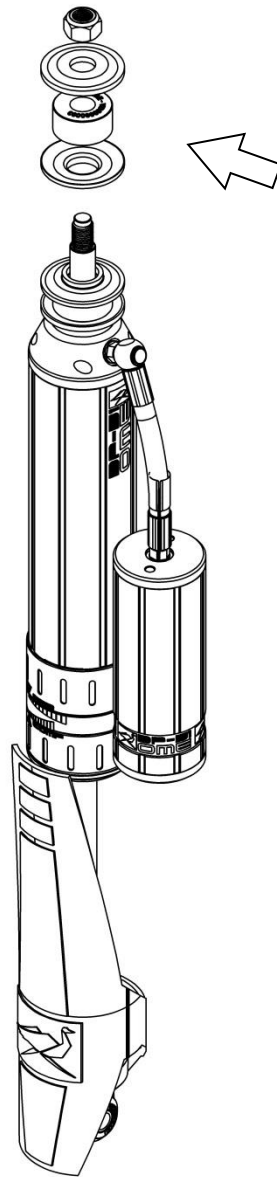

BUSH KIT VM50010006 TUNDRA

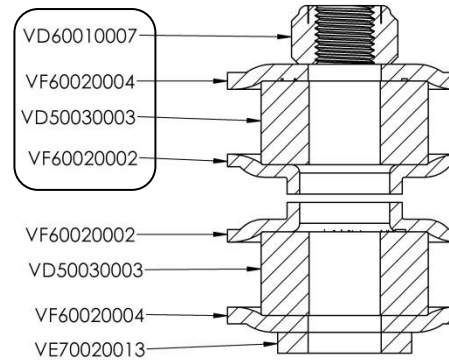

RIGHT

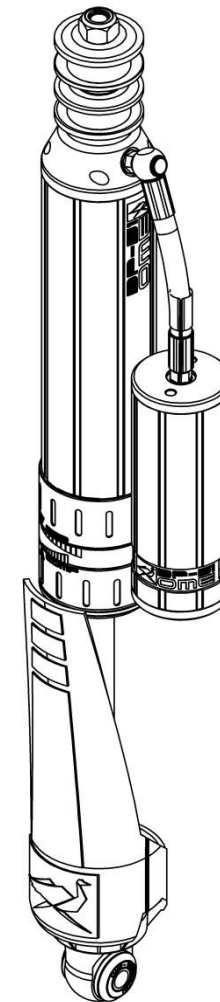

RESERVOIR MOUNTING

Step 1
Slide the reservoir mount clamp (VE10010003) over the reservoir. Fit M6 to the reservoir mount bracket (VE10020028), as shown in diagram and secure finger tight only.

Step 2
Fit reservoir mounting bracket on top of the chassis rail. Use new M8x25 bolts supplied.
Torque to 25Nm (18 lbf.ft).

Note position of reservoir to clamp shown by the photos as a guide.

Fasten hardware securely and torque where specified.

Step 3.
Tighten M6 hardware.
Torque 12Nm (9 lbf.ft)

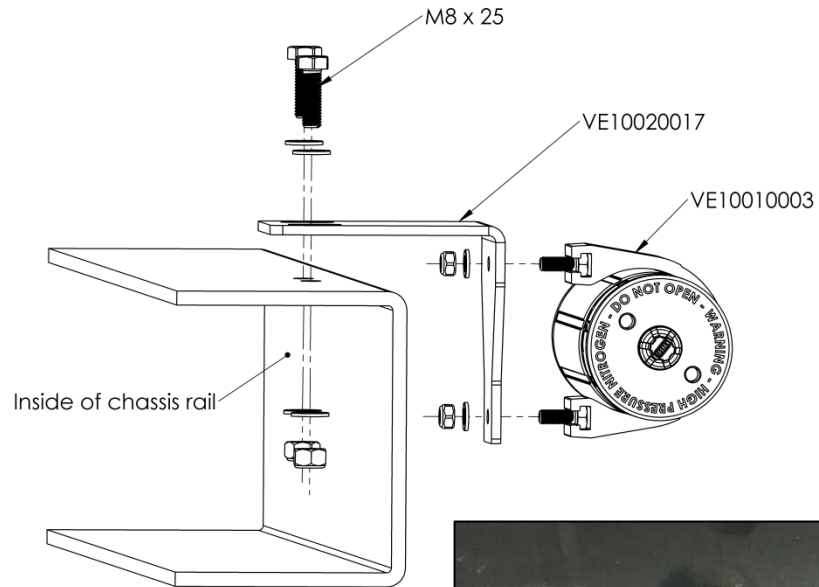

FINAL CHECKS

Be sure to check clearances once rear shocks are fitted.

A- Ensure the Banjo Hose Fitting has 10mm minimum clearance. Remove/grind minimal material from OE upper mount to provide adequate hose clearance.

B- Ensure the shaft guards are fitted as shown to protect the Shaft from front tyre roost.

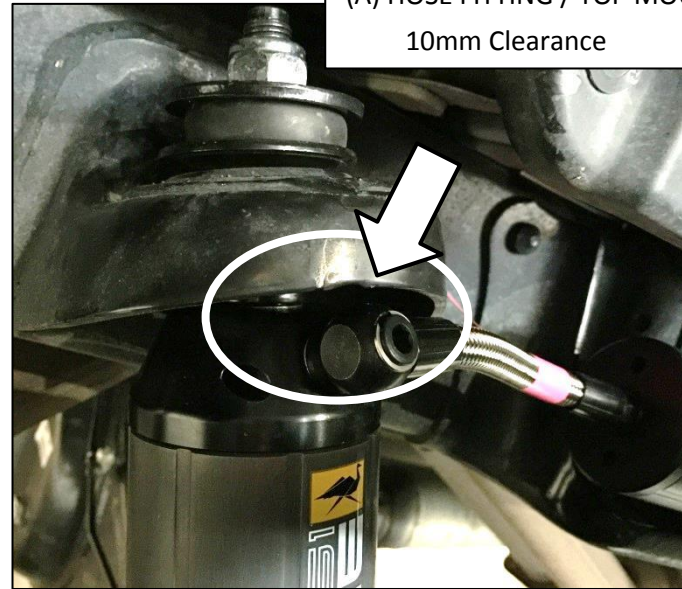

(A) HOSE FITTING / TOP MOUNT CLEARANCE
10mm Clearance



(B) DIRT SHIELD
Yellow to back of
vehicle.

SPECIFICATIONS AND SPARE PARTS

1	Spare Part: Top Bush Kit	VM50010006SP
2	Spare Part: Hose	VD81020125SP
3	Spare Part: Oil	VM80020015
4	Specification: Nitrogen Pressure	2000 kPa
5	Specification: Factory Rebound Setting	3
6	Specification: Factory Compression Setting	3
7	Spare Part: Resi Valve Kit	VM80030001SP
8	Spare Part: Stone Guard	VD31010260SP (Left) VD31020260SP (Right)
9	Spare Part: Stone Guard Mount Kit	VD31000003SP
10	Spare Part: Bottom Bush	VM50010010SP
11	Spare Part: Sleeve	
12	Spare Part: Damper Mounting Kit	VM80010035

DAMPING ADJUSTMENT

These dampers have been set in the factory to be used for a vehicle with accessories fitted. If your load or accessory fitment differs, use the table below as a guide for recommended compression (Comp) and rebound (Reb) adjuster settings. Refer to the Owner's Manual for more information.

Rear Load	Comp	Reb
0 – 200 kg	0-4	4-8
200 – 400 kg	2-6	6-10
400 – 600 kg	4-8	6-10

