

# ROUGH COUNTRY

## SUSPENSION SYSTEMS

Dodge 2009-17 Ram 1500/2500/3500 Quad Cab

2	Steps	24	8mm x 24mm x 2mm Flat Washers
2	Driver/left Front and Center Mounting Brackets	12	8mm Lock Washers
2	Passenger/right Front and Center Mounting Brackets	6	8mm Hex Nuts
1	Driver/left Rear Mounting Bracket	6	8mm Nylon Lock Nuts
1	Passenger/right Rear Mounting Bracket	6	6mm Double Bolt Plates
3	Support Brackets (DS Front/Center & PS Rear)	12	6mm x 25mm Hex Bolts
3	Support Brackets (PS Front/Center & DS Rear)	36	6mm x 22mm x 2mm Flat Washers
6	8mm Nut/Bolt Plates	12	6mm Lock Washers
6	8mm Plastic Retainers	12	6mm Nylon Lock Nuts
18	8mm-1.25 x 30 Hex Bolts	12	6mm Hex Nuts

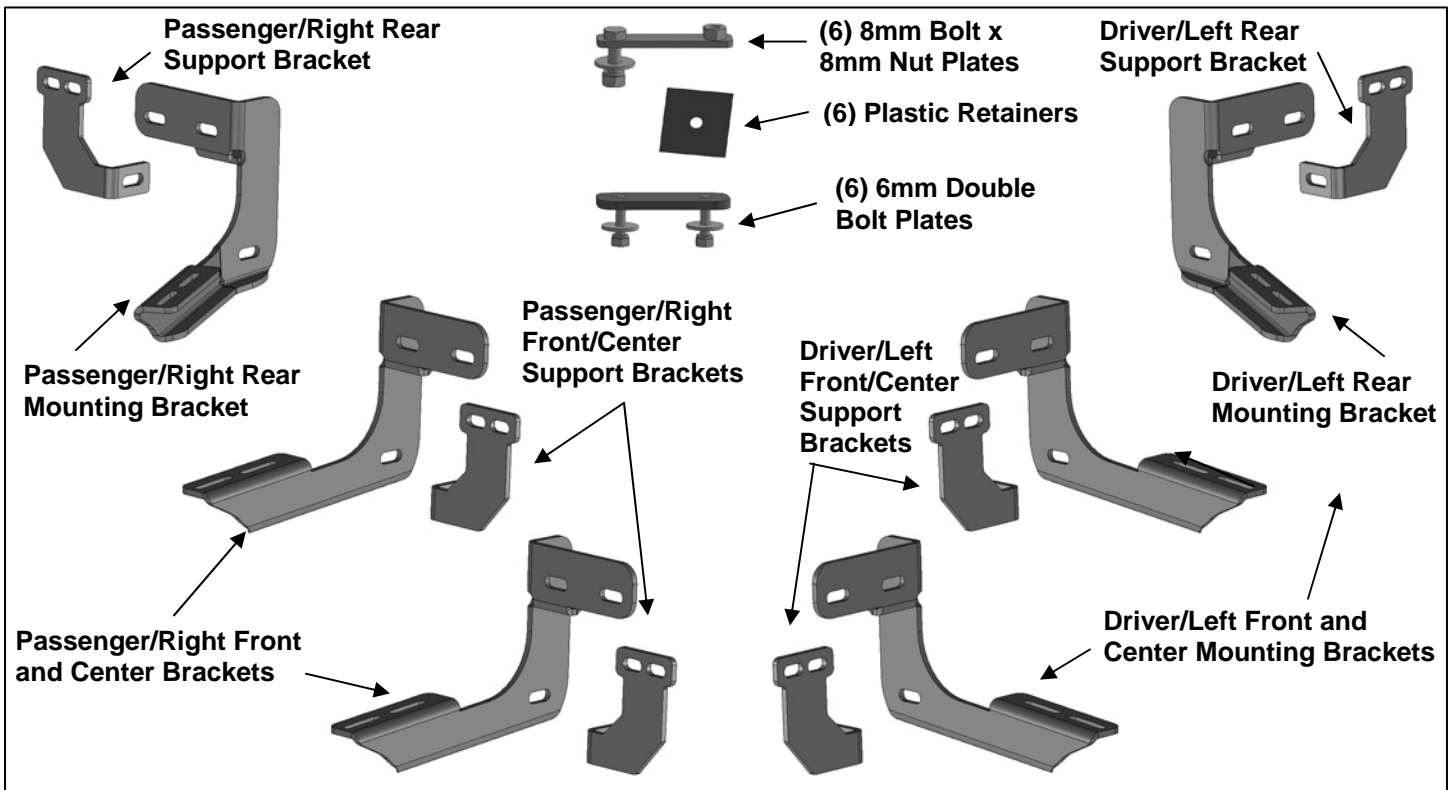

### PROCEDURE:

- REMOVE CONTENTS FROM BOX. VERIFY ALL PARTS ARE PRESENT. READ INSTRUCTIONS CAREFULLY BEFORE STARTING INSTALLATION. DRILLING MAY BE REQUIRED.**
- Starting at the driver side-front of the vehicle, remove the sealing tape covering the factory holes in the side of the inner panel, **(Figure 1)**.
- Determine the correct procedure to attach the driver side front bracket for your model/year:
 

**Models without factory threaded inserts in body panel:**

  - Partially thread an 8mm hex bolt into the threaded end of an 8mm bolt and nut plate, **(Figure 2)**. Thread the hex bolt in until it is flush with the welded nut, **(Figure 3)**. Use the hex bolt as a handle and insert the bolt and nut plate into the oval hole, **(Figure 4)**. Feed the threaded bolt on the bolt plate through one of the hex shaped factory holes. Thread (1) 8mm plastic retainer onto the threaded end and down tight against the body panel, **(Figure 5)**. **NOTE:** The plastic retainer is designed to keep the bolt/nut plate from falling into the body panel and to aid in bracket installation.
  - Select the driver side front mounting bracket, **(Figure 6)**. Attach the bracket to the threaded end of the bolt plate with (1) 8mm flat washer, (1) 8mm lock washer and (1) 8mm hex nut, **(Figure 7A)**. Do not tighten at this time.

- c. Remove the 8mm hex bolt from the nut on the bolt plate from **Step 3a**. Rotate the bolt on the bolt plate until the threaded nut lines up with the remaining hole in the mounting bracket and body panel, (**Figure 7B**). Attach the bracket to the threaded nut plate with (1) 8mm x 30mm hex bolt, (1) 8mm lock washer and (1) 8mm flat washer. Do not tighten hardware at this time.

**Models with factory threaded inserts:**

- a. Attach the driver side front bracket to the threaded inserts with (2) 8mm x 30mm hex bolts, (2) 8mm lock washers and (2) 8mm flat washer, (**Figures 8 & 9**). Leave hardware loose.
4. Next, select the driver side front support bracket. Attach the bracket to the front facing side of the front bracket with (1) 8mm x 30mm hex bolt, (2) 8mm flat washers and (1) 8mm nylon lock nut, (**Figure 10**). Rotate the support bracket to the back of the pinch weld. Line up the slots in the top of the support bracket with the (2) factory holes in the pinch weld. Attach the bracket to the back of the pinch weld with (2) 6mm x 25mm hex bolts, (4) 6mm flat washers and (2) 6mm nylon lock nuts, (**Figures 11 & 12**). Do not fully tighten hardware at this time. **IMPORTANT: 2009-10** models are not equipped with factory holes and will require drilling through the pinch weld to attach the support bracket. Do not drill through pinch weld at this time, (**see Step 9**).
5. Move along the side of the body panel to the center mounting location, (**Figure 13**). Repeat the appropriate **Step 3** to install the driver side center bracket, (**Figure 14**). Select (1) driver side front/center support bracket. Repeat **Step 4** to attach the support bracket to the front of the center bracket and factory holes (if equipped) in the pinch weld, (**Figure 15**).
6. Move to the rear location, (**Figure 15**). Repeat **Step 3** to install the rear mounting bracket, (**Figure 16**). Select the driver side rear support bracket. Repeat **Step 4** to attach the support bracket to the rear of the rear bracket and factory holes (if equipped) in the pinch weld, (**Figure 17**). **IMPORTANT:** The angled rear bracket is different from the front/center brackets, (see illustration above-note angle and direction of mounting plate).
7. Once all (3) brackets have been installed, select (1) Step. Place the Step on top of the brackets. Locate the channels in the bottom of the Step. Select (3) 6mm double bolt plates. Insert the bolt plates into the channels in the bottom of the step closest to the brackets, (**Figure 18**). Lift the step up and guide the studs through the brackets.
8. Attach the step to the brackets with (6) 6mm flat washers, (6) 6mm lock washers and (6) 6mm hex nuts, (**Figures 19 & 20**). **NOTE:** The step is designed to fit close to the vehicle. It may be necessary to loosen the bracket hardware and tilt the brackets downward to insert the step between the brackets and the body. Do not tighten hardware at this time.
9. Properly level and adjust the step and fully tighten all hardware.  
**2009-10 models requiring drilling for driver side support brackets:**
  - a. Make sure the step is level to the vehicle. Adjust and tighten all mounting hardware.
  - b. Line up the slots on the support brackets with the back of the pinch weld. Mark the location of the slots onto the pinch weld.
  - c. Drill (2) 1/4" holes through the pinch weld for each support bracket. **IMPORTANT:** Do not drill too close to the bottom edge of the pinch weld. Adjust the brackets as necessary to move the slots up the body panel away from the edge. Drill the holes toward the outside of the marked slots.
  - d. Attach each Support Bracket to the pinch weld with (2) 6mm Hex Bolts, (4) 6mm Flat Washers and (2) 6mm Nylon Lock Nuts, (**Figures 12, 14, 17, 19 & 20**). Check for level then fully tighten all hardware.
10. Move to the passenger side of the vehicle. Remove tape covering front, center and rear locations. Repeat **Steps 2—9** for passenger side step installation. **NOTE:** Refer to the illustration on **Page 1** to identify the correct mounting bracket for each of the remaining locations.
11. Do periodic inspections to the installation to make sure that all hardware is secure and tight.

**To protect your investment**, wax this product after installing. Regular waxing is recommended to add a protective layer over the finish. Do not use any type of polish or wax that may contain abrasives that could damage the finish.

**For gloss black finishes:** Mild soap may be used to clean the Steps.

## Driver Side Installation Pictured

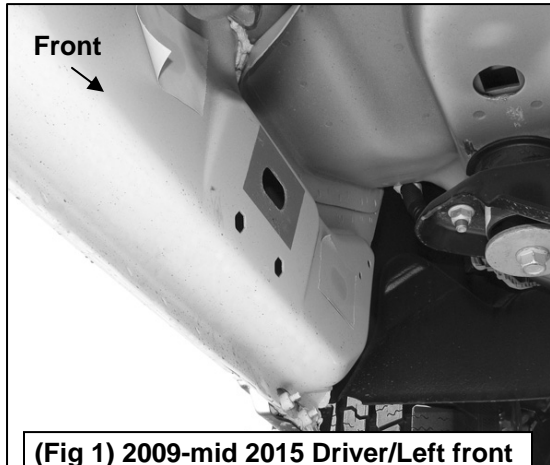

(Fig 1) 2009-mid 2015 Driver/Left front mounting location (No factory holes in pinch weld 2009-2011 models)

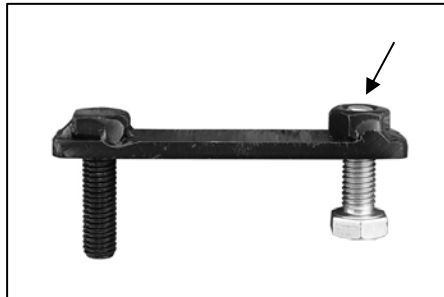

(Fig 3) Thread (1) 8mm Hex Bolt into the nut on the plate. Stop when bolt reaches end of nut as pictured



(Fig 2) 8mm Bolt-8mm nut plate, NOTE: 8mm bolt-nut plate is not required on models with threaded inserts

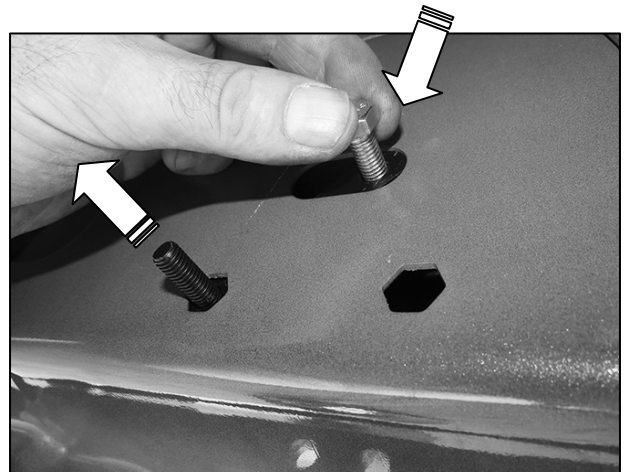

(Fig 4) Use the loose hex bolt as a handle. Insert the Bolt Plate into the oval hole and feed the threaded end out either factory hex shaped hole. IMPORTANT: Do not let go of the hex bolt until after plastic retainer has been threaded onto bolt (Fig 5)

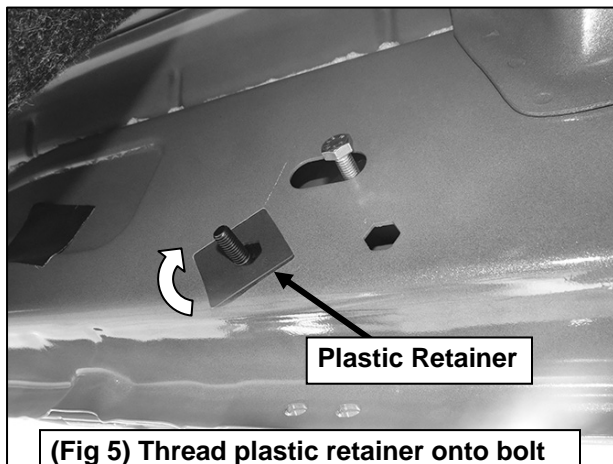

(Fig 5) Thread plastic retainer onto bolt plate to hold bolt plate in position.

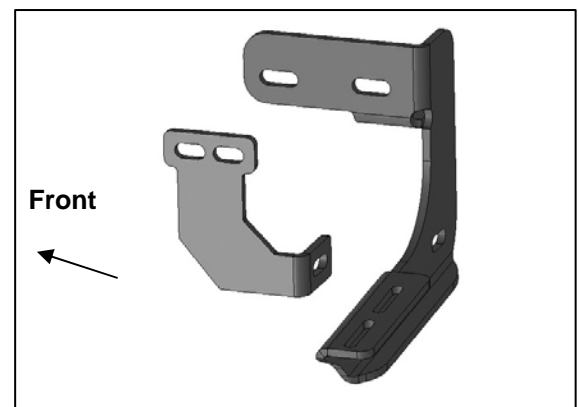

(Fig 6) Driver side front and center brackets

**Driver Side Installation Pictured**

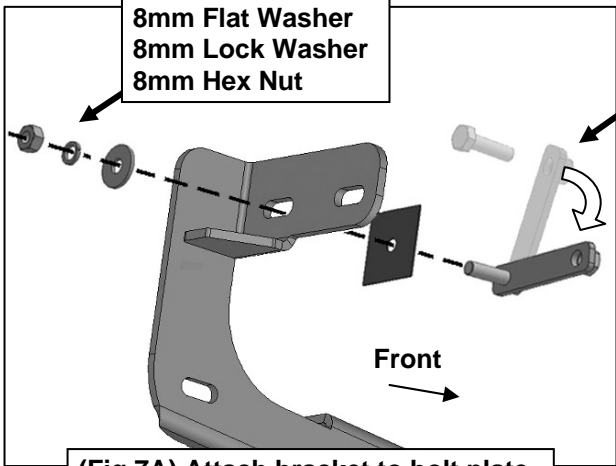

8mm Flat Washer  
8mm Lock Washer  
8mm Hex Nut

Remove hex bolt, rotate bolt/nut plate to line up threaded nut with body panel and mounting bracket (see arrow)

**(Fig 7A) Attach bracket to bolt plate**

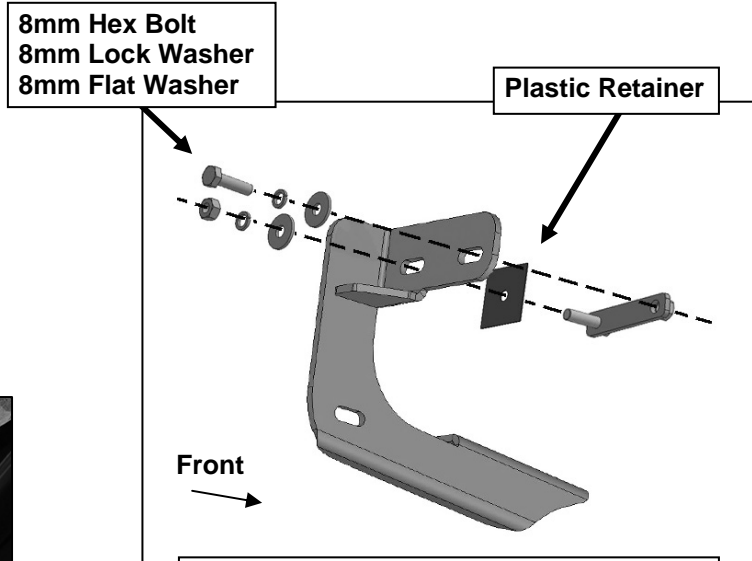

8mm Hex Bolt  
8mm Lock Washer  
8mm Flat Washer

Plastic Retainer

**(Fig 7B) Attach bracket to threaded end of bolt plate first. Remove 8mm hex bolt (see Fig 3). Rotate bolt plate to line up with remaining factory hex shaped hole.**

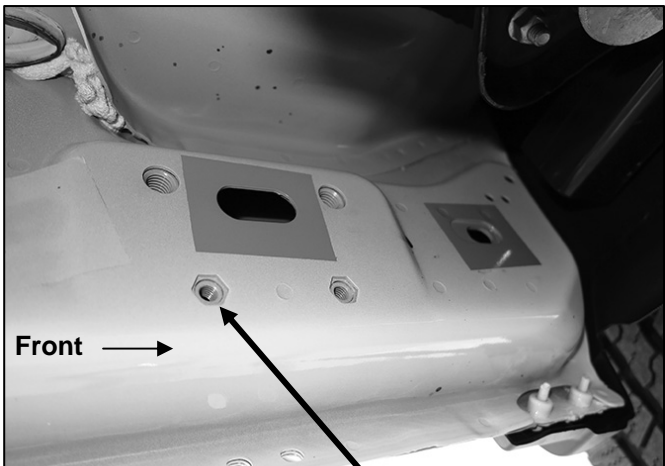

**(Fig 8) Driver side front mid 2015-on, an example of models with factory installed threaded inserts**

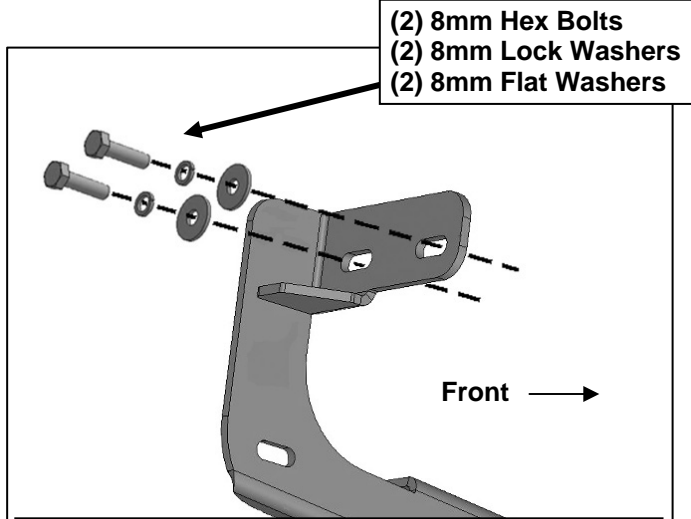

(2) 8mm Hex Bolts  
(2) 8mm Lock Washers  
(2) 8mm Flat Washers

**(Fig 9) Driver side front models with factory installed threaded inserts. Bolt Plate not required**

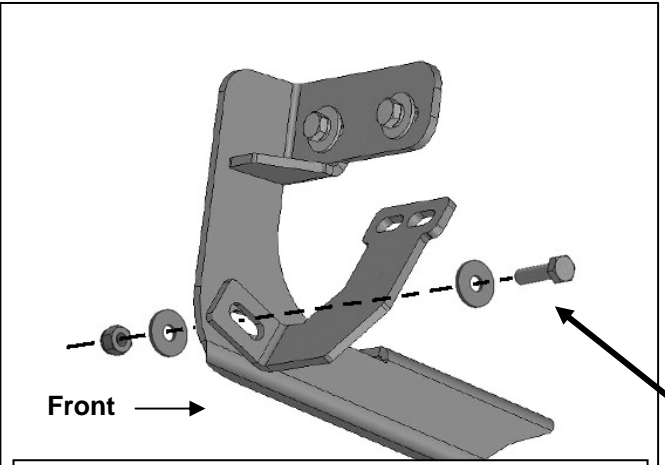

**(Fig 10) Attach Driver/Left front support bracket to front facing side of mounting bracket**

8mm Hex Bolt  
(2) 8mm Flat Washers  
8mm Nylon Lock Nut

## Driver Side Installation Pictured

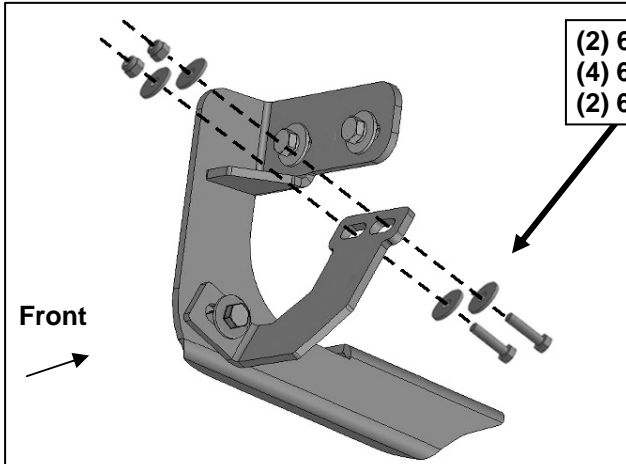

(2) 6mm Hex Bolts  
(4) 6mm Flat Washers  
(2) 6mm Nylon Lock Nuts

8mm Hex Bolt  
(2) 8mm Flat Washers  
8mm Nylon Lock Nut

(2) 6mm Hex Bolts  
(4) 6mm Flat Washers  
(2) 6mm Nylon Lock Nuts

(Fig 11) Attach support bracket to back of pinch weld (models with factory holes in pinch weld only)

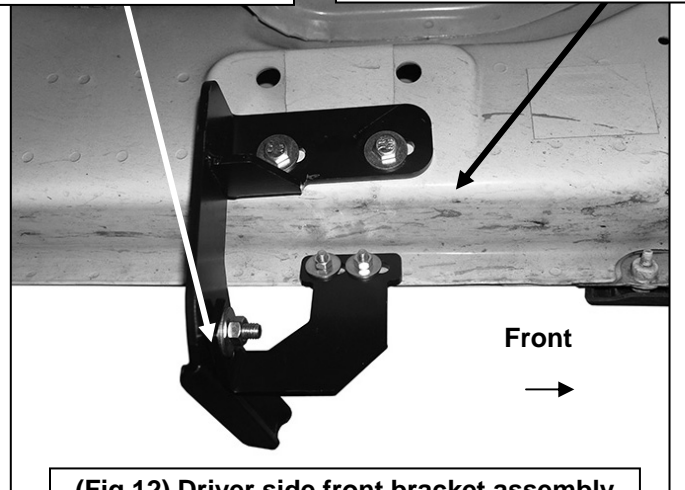

(Fig 12) Driver side front bracket assembly

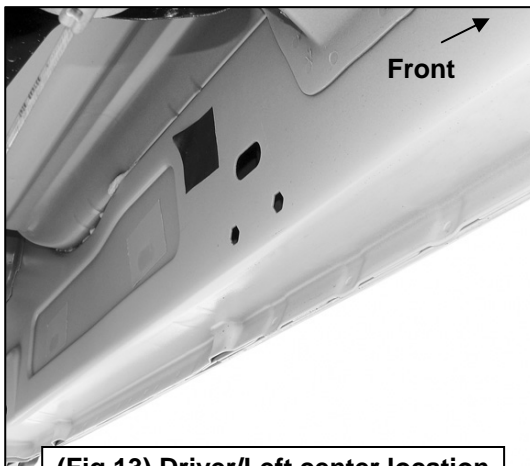

(Fig 13) Driver/Left center location

8mm Hex Bolt  
(2) 8mm Flat Washers  
8mm Nylon Lock Nut

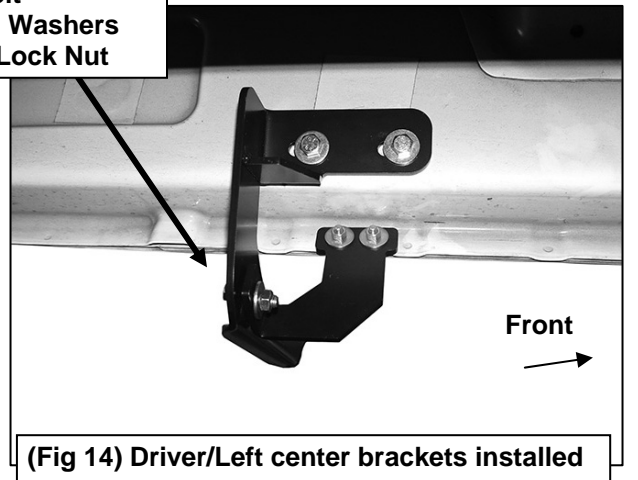

(Fig 14) Driver/Left center brackets installed

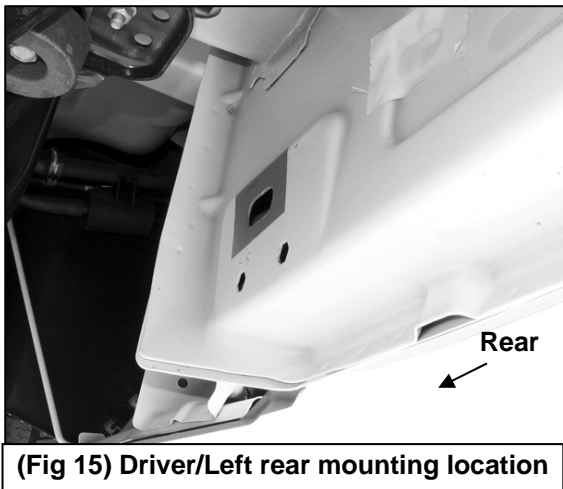

(Fig 15) Driver/Left rear mounting location

**IMPORTANT:** 2009-2010 models without holes in pinch weld will require drilling 1/4" holes through pinch weld to attach support brackets. Do complete installation of steps first and level steps before drilling holes for support brackets.

## Driver Side Installation Pictured

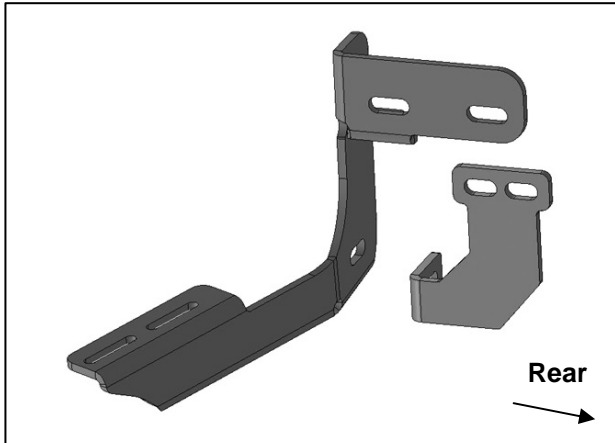

(Fig 16) Driver/Left angled rear mounting brackets

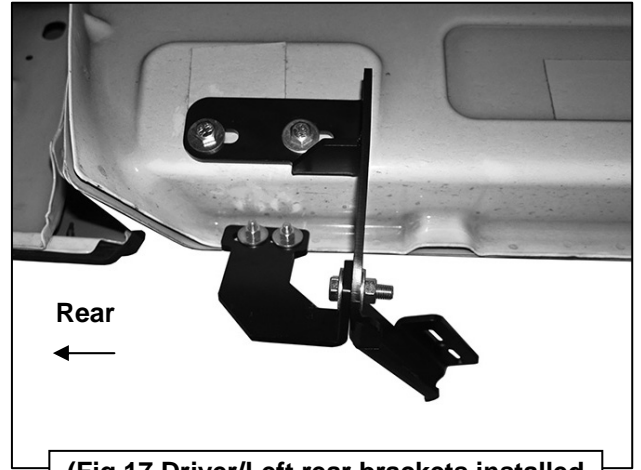

(Fig 17) Driver/Left rear brackets installed

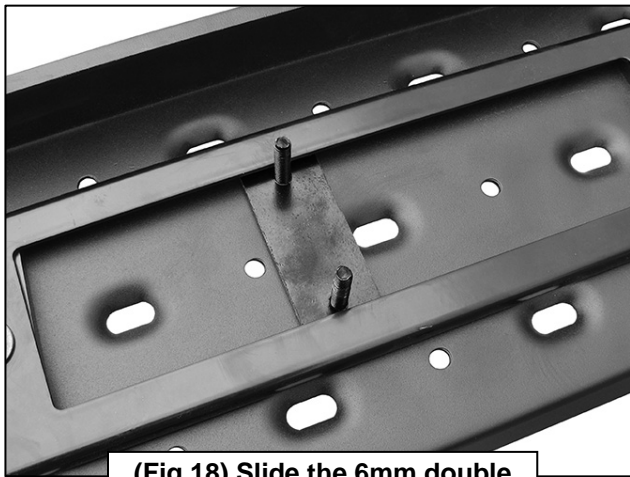

(Fig 18) Slide the 6mm double bolt plate into channels

(2) 6mm Flat Washers  
(2) 6mm Lock Washers  
(2) 6mm Hex Nuts

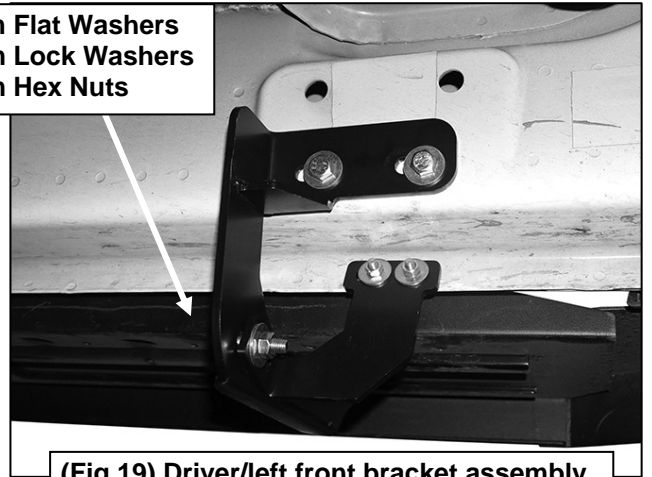

(Fig 19) Driver/left front bracket assembly

(2) 6mm Flat Washers  
(2) 6mm Lock Washers  
(2) 6mm Hex Nuts

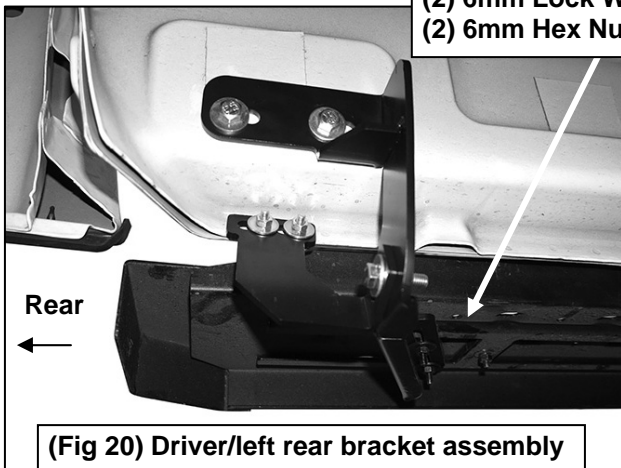

(Fig 20) Driver/left rear bracket assembly

By purchasing any item sold by Rough Country, LLC, the buyer expressly warrants that he/she is in compliance with all applicable, State, and Local laws and regulations regarding the purchase, ownership, and use of the item. It shall be the buyer's responsibility to comply with all Federal, State and Local laws governing the sales of any items listed, illustrated or sold. The buyer expressly agrees to indemnify and hold harmless Rough Country, LLC for all claims resulting directly or indirectly from the purchase, ownership, or use of the items.