

ROUGH COUNTRY

SUSPENSION SYSTEMS®

Bolt-On/Rugged Fender Flares Toyota Tundra (07-13) FIT-FF759

Please read instructions entirely before installing this product.

| Hardware Included | QTY |
|-------------------|------|
| ALCOHOL TOWELETTE | 4 |
| CLIP .9MM | 6 |
| EXTRUSION | 28ft |
| GROMMET | 2 |

| | |
|------------|----|
| SCRIVET M6 | 2 |
| SPACER 9MM | 10 |
| SCREW 12G | 10 |
| SCREW 14G | 24 |
| | |

| Bolt Kit Included | QTY |
|-------------------|-----|
| ALLEN KEY BOLT | 42 |
| NUT | 42 |
| | |
| | |

Ensure that both left and right hand Fender Flares suit the profile of the vehicle. Note the areas where the Fender Flares come in contact with the vehicle. NOTE: Before fitting Fender Flares remove any moldings, strips or existing flares from the wheel arch. If there is a body side molding, mark where the molding is to be cut, alternatively the Fender Flare can be cut to go around the molding. Be sure to allow enough room for the extrusion.

***PRIOR TO ANY PAINTING & INSTALLATION, PRODUCT SHOULD BE THOROUGHLY INSPECTED FOR ALL COMPONENTS LISTED ABOVE. PRODUCT SHOULD ALSO BE TEST FITTED PRIOR TO ANY PAINTING & INSTALLATION. PLEASE CONTACT ROUGH COUNTRY IF YOU HAVE ANY FITMENT QUESTIONS AND OR MISSING COMPONENTS.**

***For Rugged look flares begin installation at STEP 2.**

PAINTING INSTRUCTIONS – If Fender Flares are being painted; do not install edge extrusion until painting is complete. Prior to painting, clean all surfaces to be painted using clean water and a mild detergent, do not use lacquer thinner or any solvent based products. Wipe completely dry. Best results will be achieved by wiping the areas to be painted with a tack rag just prior to painting. Most automotive paints can be applied directly to the Fender Flares, however some may require a primer (check paint manufacturer specifications). Good adhesion will be achieved without sanding. Select a paint (and primer if necessary) that is suitable for rigid plastics PMMA (Acrylic). If using a paint system that requires baking, do not expose the product to temperatures above 70°C (158°F). Do not fit the extrusion or any of the hardware to the Fender Flares until the paint is completely dry.



STEP 1: Attach 10 bolts to each Fender Flare using a 3/16" Allen key and a 10.0mm wrench/socket. (wrench/socket and Allen key not supplied). Ensure inside of Fender Flares where the rubber seal is attached is clean, using the alcohol wipes provided. Wipe away any residue with a dry clean cloth.



STEP 2: Attach the included rubber seal to the Fender Flares. Peel back 2" of the adhesive backing and position on the Fender Flare. Attach the seal to the Fender Flare, peeling back a few inches at a time. Attach rubber seal along all areas the Fender Flare will make contact with the vehicle body.

ROUGH COUNTRY

SUSPENSION SYSTEMS®

Bolt-On/Rugged Fender Flares Toyota Tundra (07-13) FIT-FF759



STEP 3: Pulling at right angles to the extrusion, remove the liner from the extrusion in small portions and apply thumb pressure to ensure that it adheres to the Fender Flares.

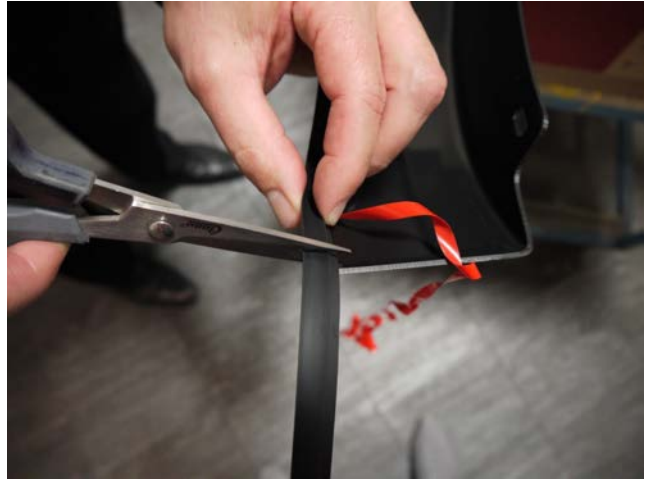

STEP 4: Trim any unnecessary extrusion and discard.



STEP 5: Clean the body areas where the Fender Flares will make contact..



STEP 6: Remove factory mud flap from vehicle by removing the 2 screws from the mud flap corresponding to the holes in the Fender Flare. For vehicles with chrome bumper remove and discard the fastener. For bumpers with body color remove and retain fastener.

ROUGH COUNTRY

SUSPENSION SYSTEMS

Bolt-On/Rugged Fender Flares Toyota Tundra (07-13) FIT-FF759



STEP 7: Place Fender Flare on vehicle and attach the screw and the fastener as shown. Do not fully tighten at this stage.

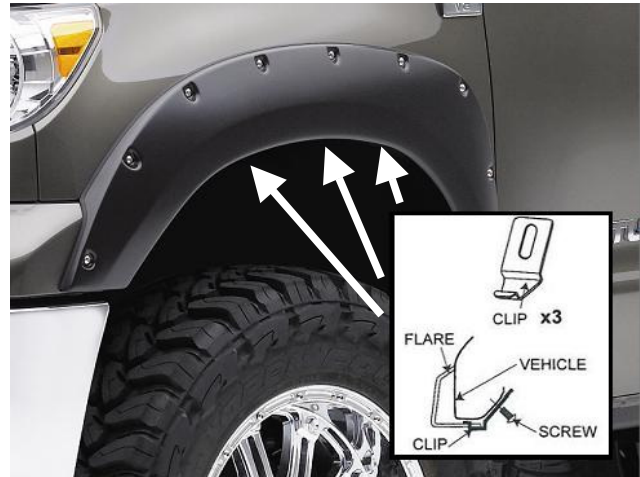

STEP 8: Locate the clips in the slots on the Fender Flare as shown. Secure to vehicle using the screws supplied.



STEP 9: If necessary, make minor adjustments to the Fender Flare's position to achieve the best fit for your vehicle. Once satisfied, tighten all screws currently installed.

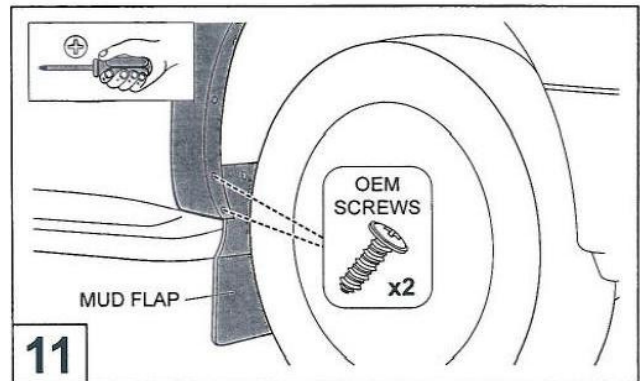

STEP 10: If the vehicle is equipped with mud flaps, line up with the screw plugs and replace and tighten the OEM screws. For vehicles without mudflaps, proceed to Step 11.

ROUGH COUNTRY

SUSPENSION SYSTEMS

Bolt-On/Rugged Fender Flares Toyota Tundra (07-13) FIT-FF759

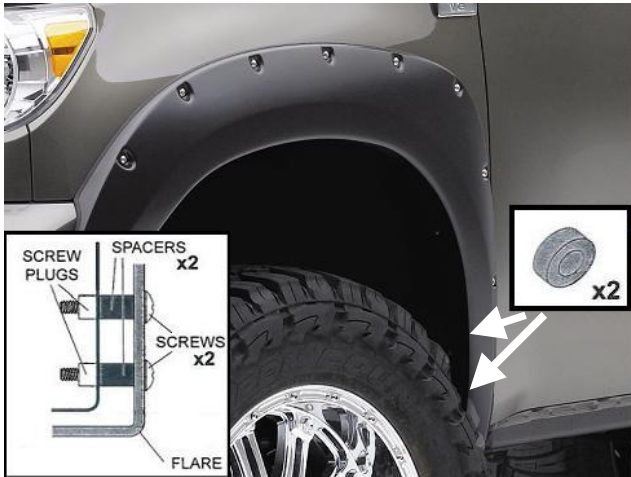

STEP 11: Slide the supplied spacers up behind the Fender Flare to fill the gap between the Fender Flare and the fender. Use a screwdriver to locate the spacers in line with the screw plugs. Once lined up, use 2x screws to secure the Fender Flare to the fender. Repeat for the opposite side.

ROUGH COUNTRY

SUSPENSION SYSTEMS

Bolt-On/Rugged Fender Flares Toyota Tundra (07-13) FIT-FF759

REAR FENDER FLARE INSTALLATION



STEP 12: Attach 12 bolts to the RHS Fender Flare and 10bolts to the LHS Fender Flare using a 3/16" Allen key and a 10.0mm wrench/socket. (wrench/socket and Allen key not supplied). Ensure inside of Fender Flares where the rubber seal is attached is clean, using the alcohol wipes provided. Wipe away any residue with a dry clean cloth



STEP 13: Attach the included rubber seal to the Fender Flares. Peel back 2" of the adhesive backing and position on the Fender Flare. Attach the seal to the Fender Flare, peeling back a few inches at a time. Attach rubber seal along all areas the Fender Flare will make contact with the vehicle body. Trim any excess rubber seal.



STEP 14: Clean the body areas where the Fender Flares will make contact.

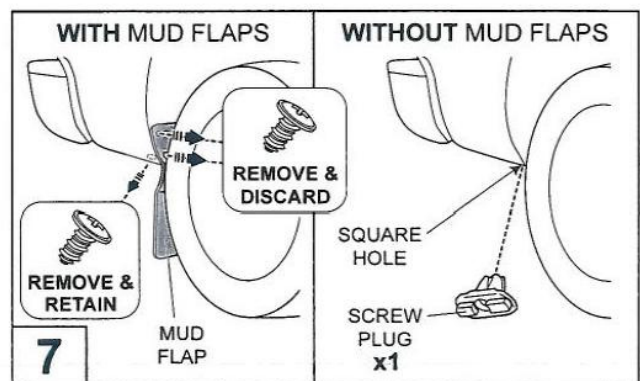

STEP 15: If vehicle is equipped with mud flaps, remove the two (2) screws from the mud flap corresponding to the holes in the Fender Flare and discard. Also remove the screw from the underside of the mudflap and retain. If the vehicle is not fitted with mud flaps, install the plastic screw plug provided into the square hole.

ROUGH COUNTRY

SUSPENSION SYSTEMS

Bolt-On/Rugged Fender Flares Toyota Tundra (07-13) FIT-FF759



STEP 16: Place Fender Flare on the vehicle and attach 7 small screws into the original screw plugs in the positions shown.

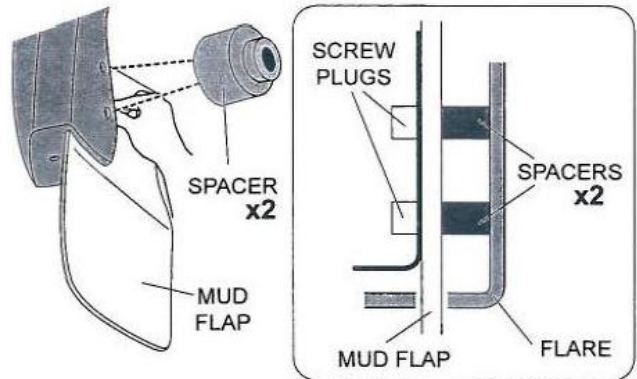

STEP 17: Once in position, slide the spacers up behind the flare to fill the gap between the flare and the mud flap. Use a screwdriver to locate the spacers in line with the screw plugs.

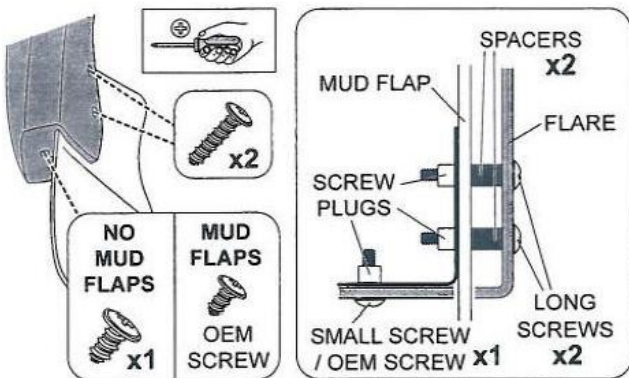

STEP 18: Once lined up, use the OEM screw and two (2) long screws to secure the Fender Flare and mud flaps to the fender as shown.

If the vehicle has no mud flaps, the procedure is the same and all the steps should still be followed, however, all references to the mud flap should be disregarded, and use the one (1) small screw at the very lower hole.

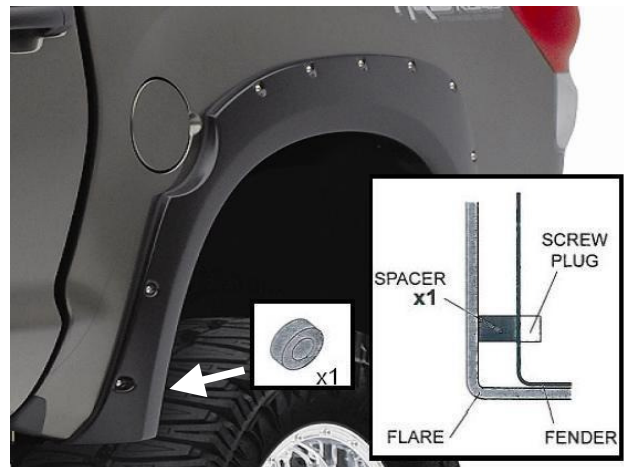

STEP 19: At the front of the fender, slide a spacer up behind the Fender Flare to fill the gap between the Fender Flare and the fender. Use a screwdriver to locate the spacer in line with the screw plug. Once lined up, use a long screw to secure.

ROUGH COUNTRY

SUSPENSION SYSTEMS®

Bolt-On/Rugged Fender Flares **Toyota Tundra (07-13)** FIT-FF759



STEP 20: Make any necessary adjustments to achieve best fit. Once satisfied, tighten all fixtures. Repeat procedure for the opposite Fender Flare.