

ROUGH COUNTRY

SUSPENSION SYSTEMS®

Rough Country Bull Bar w/ 20" LED LIGHT MOUNT

Thank you for choosing Rough Country for all your off road needs.

▲ NOTICE Rough Country Lights are intended for off road use only

Please read instructions before beginning installation. Check the kit hardware against the kit contents shown below. Be sure you have all needed parts and know where they go.

If questions exist, please call us @ 1-800-222-7023. We will be happy to answer any questions concerning the design, function, and correct use of our products.

INSTALLATION INSTRUCTIONS

1. Place light in between light mounts on inside of bull bar. **See Photo 1.**
2. Using supplied hardware and Allen wrench, center light and tighten. **See Photo 2.**



3. Locate an appropriate location in the vehicle for the switch mounting.
4. Route the harness to the mounting location. *Do not secure at this time.* The wiring will be zip-tied after the lights are installed and adjusted to ensure the wiring can reach the lights.

Beware of sharp edges, abrasive surfaces and heat sources. Re-route wiring as needed. Make sure when mounting the relay, attach in a dry area where the wires coming out of the relay are facing down.

5. After the light is mounted, the wiring harness simply plugs into the light pigtail. Take care not to damage the wires.
6. Attach the red terminal to the (+) side of the battery, or any 12V DC Source.
7. Secure the black terminal to a suitable ground, or the Negative (-) side of the battery.

▲ NOTICE Some lights have multiple positive and negative wires.

8. Secure any part of the wiring harness away from hazards using zip-ties.

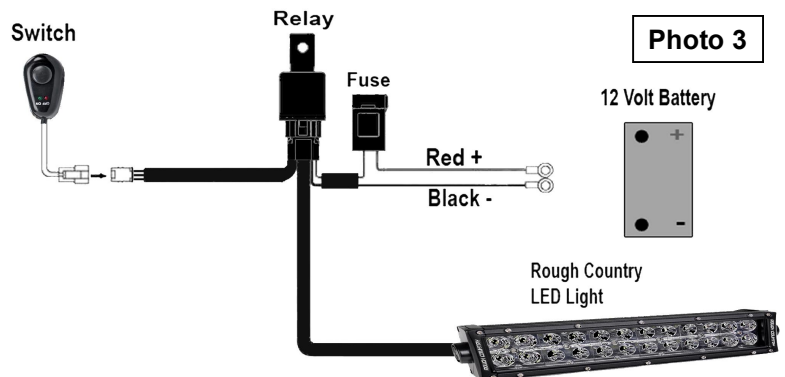

By purchasing any item sold by Rough Country, LLC, the buyer expressly warrants that he/she is in compliance with all applicable Federal, State, and Local laws and regulations regarding the purchase, ownership, and use of the item. It shall be the buyers responsibility to comply with all Federal, State and Local laws governing the sales of any items listed, illustrated or sold. The buyer expressly agrees to indemnify and hold harmless Rough Country, LLC for all claims resulting directly or indirectly from the purchase, ownership, or use of the items.





PARTS LIST:

Qty	Description	Qty	Description
1	3" Bull Bar	8	10-1.50mm Nylon Lock Nuts
1	Driver side Frame Bracket	4	8-1.25mm x 35mm Hex Bolts
1	Passenger Side Frame Bracket	4	8mm x 22mm OD x 2mm Flat Washers
2	Bull Bar Mounting Brackets	4	8mm Lock Washers
4	12mm x 40mm Bolt Plates	1	20" Single Row LED Light Bar
4	12mm x 32mm OD x 3mm Flat Washer	2	D8 Lock Washer(Light Bar)
4	12mm Lock Washers	2	8mmx24mmx2mm Large Flat Washer(Light Bar)
4	12-1.75mm Hex Nuts	2	8mm_16mm Hex Bolt(Full Thread) (Light Bar)
2	10mm U-Bolt (for use on "closed frames" only)	1	License Plate Mounting Bracket
4	10-1.50mm x 35mm Hex Bolts	2	6mm Hex Nut(License Plate)
12	10mm x 27mm OD x 3mm Flat Washers	2	D6 Flat Washer(License Plate)
4	PVC Plastic Bock	4	Assembly For M6 Button Head Screw/ M6 Lock Washer/M6 Flat Washer(License Plate)

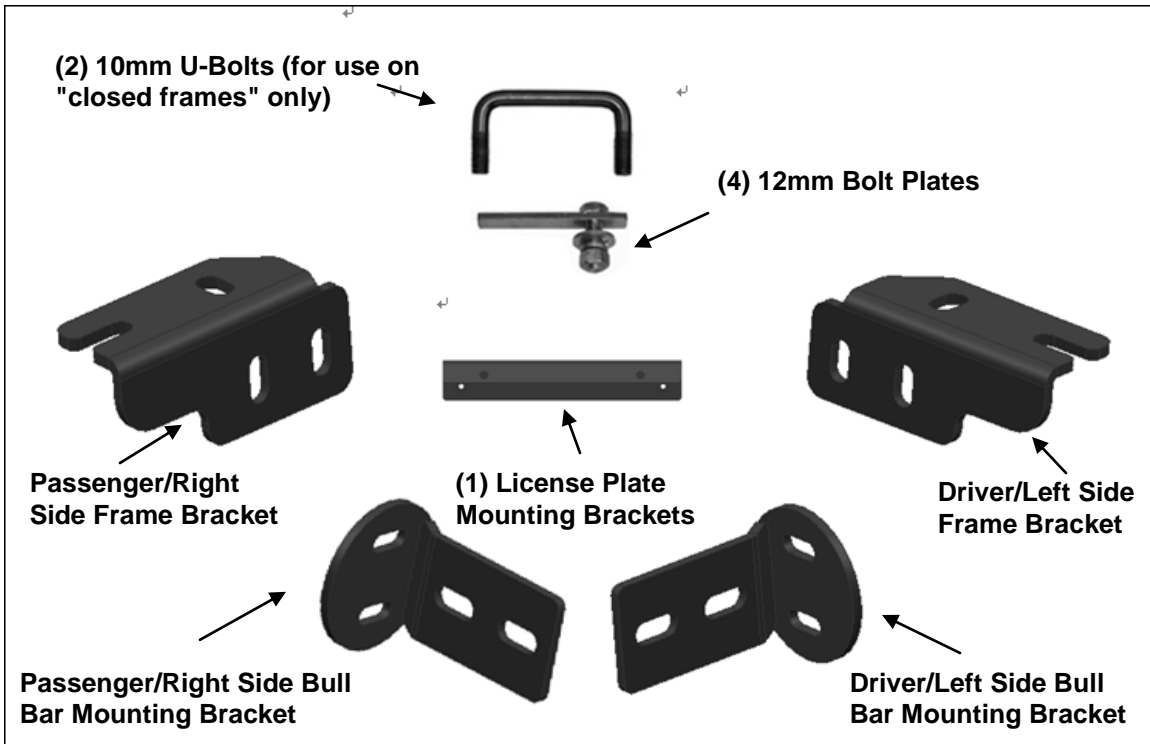

PROCEDURE:

1. REMOVE CONTENTS FROM BOX. VERIFY ALL PARTS ARE PRESENT. READ INSTRUCTIONS CAREFULLY BEFORE STARTING INSTALLATION. CUTTING



MAY BE REQUIRED. ASSISTANCE IS RECOMMENDED. NOTE: It may be necessary to remove/relocate the front license plate and license plate bracket. It is not required, but strongly recommended. If local/state law requires a license plate, license plate relocation kit is available.

2. Determine if the vehicle is equipped with tow hooks, **(Figure 1)**.

Vehicles with Factory Tow Hooks

- a. Remove each tow hook by removing the front bolt and only loosening the rear bolt, **(Figure 2)**. Slide the tow hook off. Keep the factory double nut plate in the frame and aligned with the holes. **NOTE:** Tow hooks cannot be reinstalled.
- b. Select the driver side Frame Bracket. Position the Bracket up to the bottom of the frame. Reuse the tow hook hardware to attach the Bracket to the bottom of the frame and factory double nut plate, **(Figure 3)**.
- c. Repeat to install the passenger side Frame Bracket.
- d. Skip to **Step 3**.

All vehicles without Tow Hooks

Remove the lower plastic portion of the bumper to gain access to the ends of the frame rails, **(Figure 4)**. The lower bumper or splash guard will need to be cut out to allow the Mounting Brackets and end of Bull Bar to pass through. On some models, access to the mounting hardware is limited. For access, first remove the plastic bumper cover from each side of the opening and in the center of the bumper, **(Figure 5)**.

Vehicles without Tow Hooks and open end of frame

- a. Starting on the driver side of the vehicle, insert (1) 12mm Bolt Plate through the opening in the end of the frame and down through the rear hole in the bottom of the frame, **(Figure 6A)**. Thread (1) 12mm Flat Washer, (1) 12mm Lock Washer and (1) 12mm Hex Nut onto the end of the Bolt Plate.
- b. Slide the slotted end of the driver side Bracket under the nut and washers. Insert the second 12mm Bolt Plate through the remaining hole toward the front of the Mounting Bracket. Secure the Bracket to the Bolt Plate with (1) 12mm Lock Washer, (1) 12mm Flat Washer and (1) 12mm Hex Nut, **(Figure 6B)**.
- c. Snug but do not tighten the hardware at this time.
- d. Repeat to install the passenger side frame Bracket.

Vehicles without Tow Hooks, closed end of frame

- a. Starting on the driver side of the vehicle, locate the two holes on the bottom of the frame. Insert (1) 10mm U-Bolt into one hole and out the other, **(Figures 7A & 7B)**.
 - b. Hold the driver side Bracket up in position with the slotted end toward the rear. Secure the Bracket to the U-Bolt with (2) 10mm Flat Washers and (2) 10mm Nylon Lock Nuts, **(Figure 8)**.
 - c. Snug but do not tighten the hardware.
 - d. Repeat to install the passenger side frame Bracket.
3. Next, carefully unwrap the Bull Bar. Select the driver side Bull Bar Mounting Bracket, **(Figure 9)**. Attach the Bracket to the end of the Bull Bar with (2) 8mm x 35mm Hex Bolts, (2) 8mm Lock Washers and (2) 8mm Flat Washers, **(Figures 10A & 10B)**. Center the mounting flange on the Bracket with the end of the tube on the Bull Bar. Snug but do not tighten hardware. Repeat this Step to install the passenger side Mounting Bracket.
 4. With assistance, line up the mounting tabs on the Bull Bar with the inside of the (2) previously installed Frame Mounting Brackets. Bolt the Bull Bar to the Brackets with the included (4) 10mm x 35mm Hex Bolts, (8) 10mm Flat Washers, (4) 10mm Nylon Lock Nuts, **(Figure 11)**. Snug but do not tighten hardware at this time.
 5. Level and adjust the Bull Bar properly and tighten all hardware.

Models without openings in lower bumper or splash guard for tow hooks. Hold the cover up to the bottom of the bumper, **(Figure 12A)**. Trace the location of both Brackets onto the back of the cover. Temporarily remove the Bull Bar with attached Tube Brackets only. Cut openings in the cover to clear the Frame Brackets and end of Bull Bar as necessary, **(Figure 12B)**. For best results, start with a small slot and slowly



enlarge the opening to clear the Brackets. Once cover is properly fit to the Brackets, reinstall the cover and Bull Bar as previously described.

6. Do periodic inspections to the installation to make sure that all hardware is secure and tight.

To protect your investment, wax this product after installing. Regular waxing is recommended to add a protective layer over the finish. Do not use any type of polish or wax that may contain abrasives that could damage the finish.

For stainless steel: Aluminum polish may be used to polish small scratches and scuffs on the finish. Mild soap may be used also to clean the Bull Bar.

For gloss black finishes: Mild soap may be used to clean the Bull Bar.

Driver Side Installation Pictured

Remove tow hooks if equipped

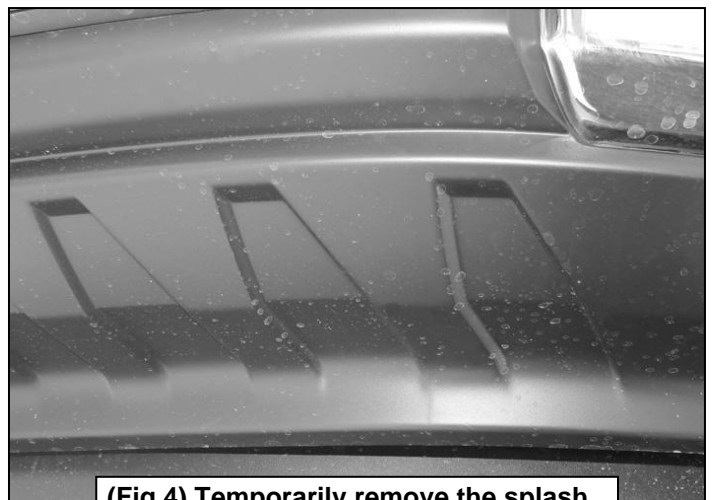
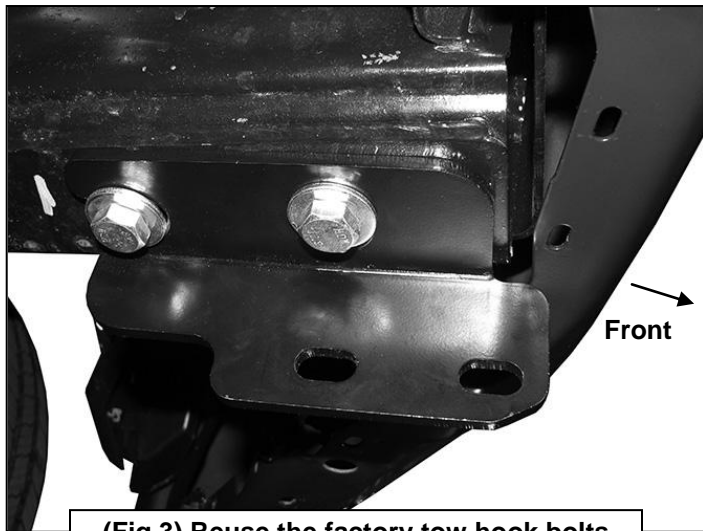
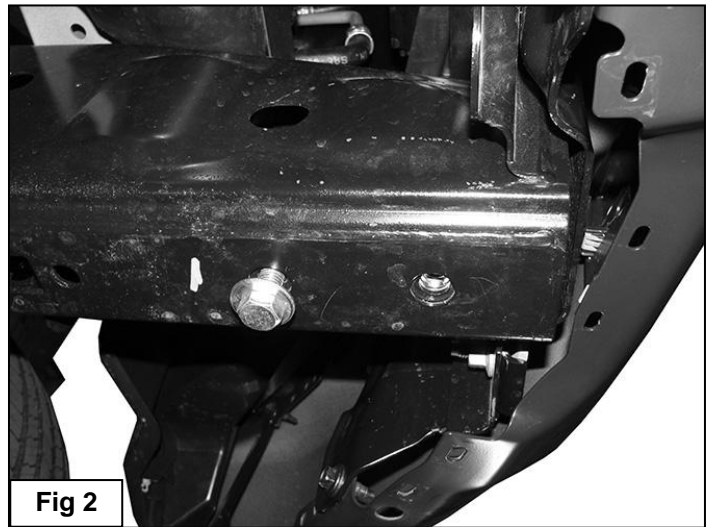

Driver Side Installation Pictured



(Fig 5) Remove bumper pads to access splash guard hardware if necessary. 2015 F150 pictured

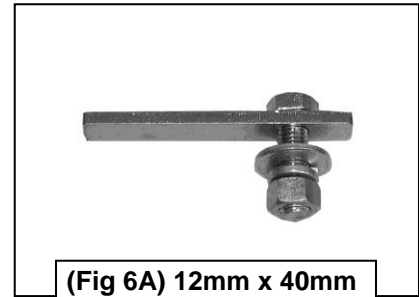

(Fig 6A) 12mm x 40mm Bolt Plates

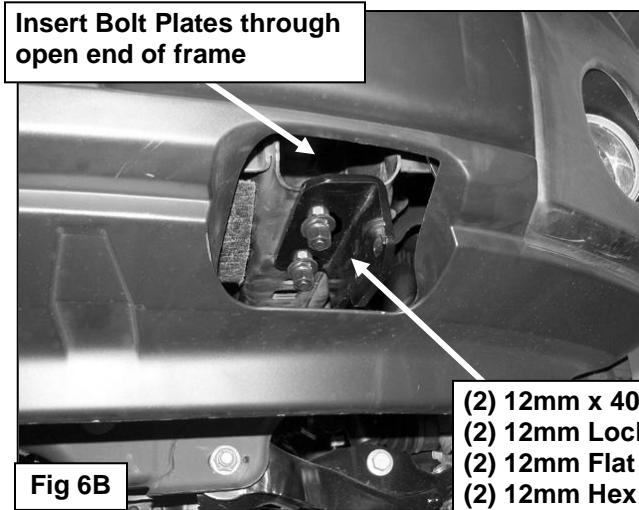

Insert Bolt Plates through open end of frame



(Fig 7A) 10mm U-Bolt

- (2) 12mm x 40mm Bolt Plates
- (2) 12mm Lock Washers
- (2) 12mm Flat Washers
- (2) 12mm Hex Nuts

Fig 6B

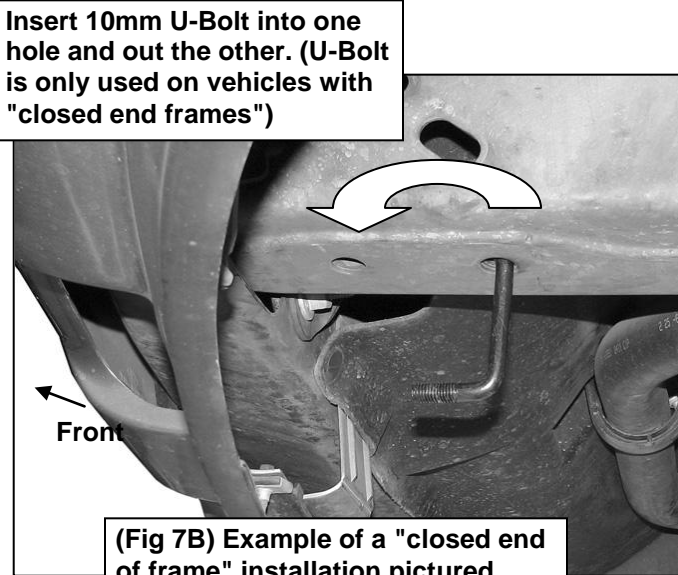

Insert 10mm U-Bolt into one hole and out the other. (U-Bolt is only used on vehicles with "closed end frames")

- 10mm U-Bolt
- (2) 10mm Flat Washers
- (2) 10mm Nylon Lock Nuts

(Fig 7B) Example of a "closed end of frame" installation pictured

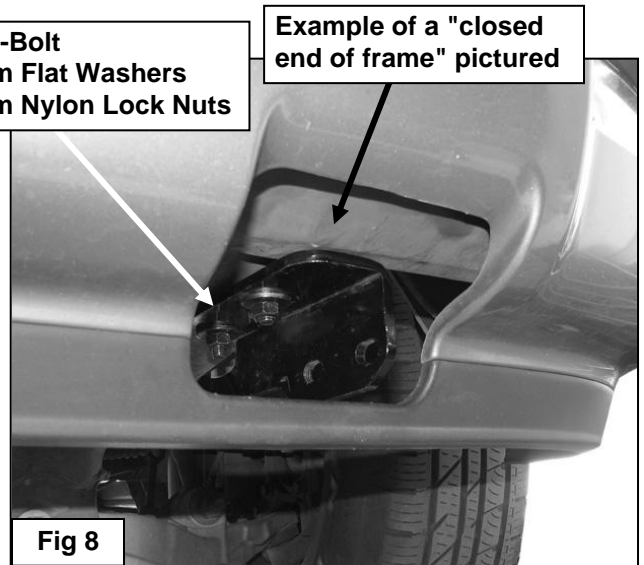

Example of a "closed end of frame" pictured

Fig 8

Driver Side Installation Pictured

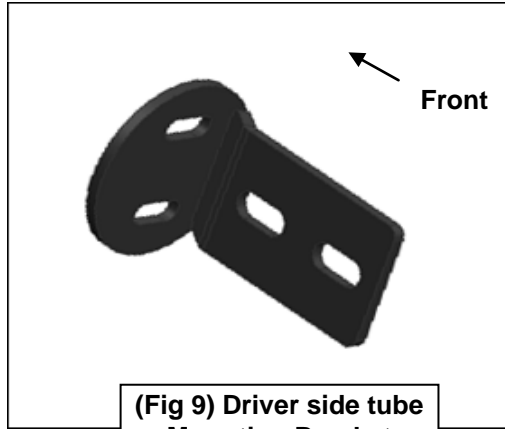

(Fig 9) Driver side tube Mounting Bracket

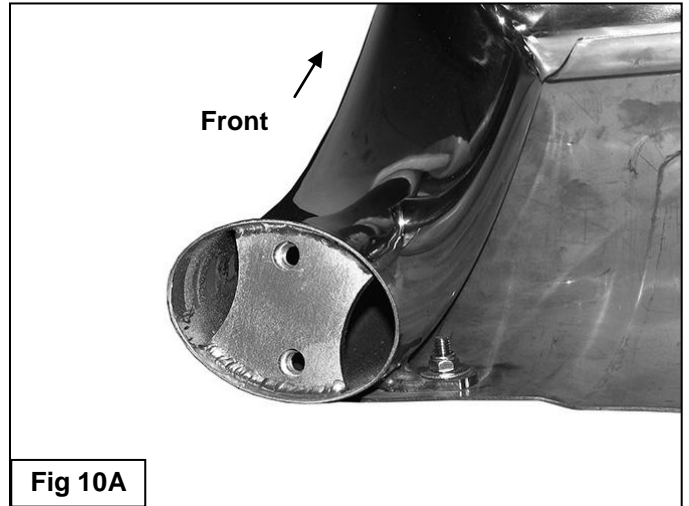

Fig 10A

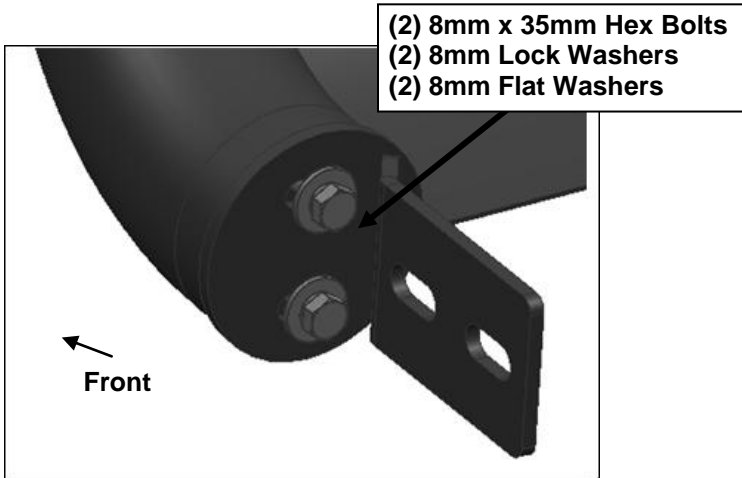

Fig 10B

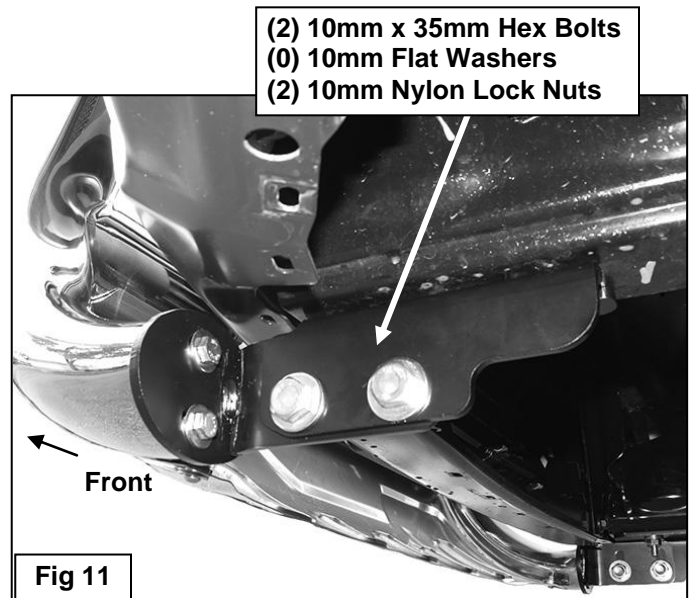

Fig 11

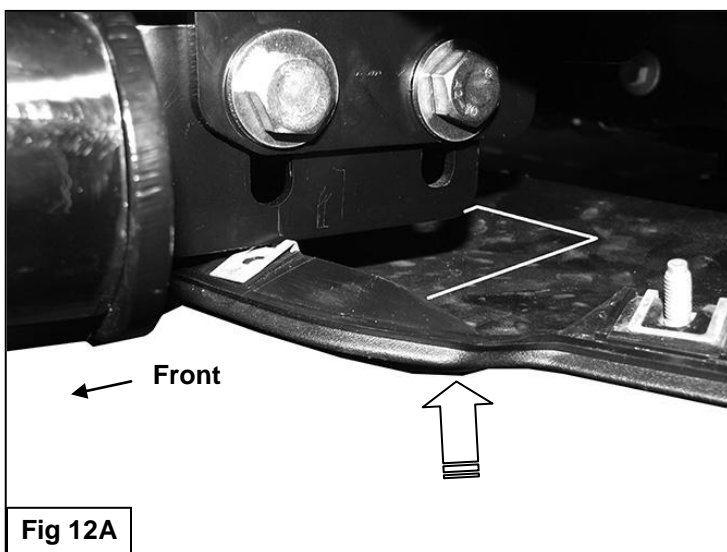

Fig 12A

Hold the splash guard up to the bottom of the Brackets. Trace the location of the Brackets onto the inside of the splash guard. Use a sharp knife or hacksaw blade to cut out the plastic cover. Only cut enough to clear the Brackets, do not cut through the front or rear edges of the cover.

Driver Side Installation Pictured

