

# ROUGH COUNTRY

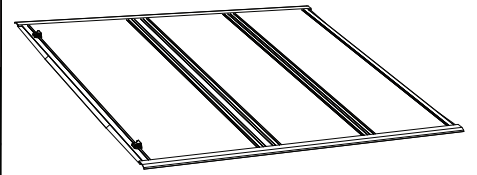

## Hard Folding Cover

Fits: 47620500- 2020-Current Jeep Gladiator JT



30-60 min

Cutting Required

Drilling Not Required



THE ROUGH COUNTRY HARD FOLDING COVER COMES FULLY ASSEMBLED.



[www.roughcountry.com](http://www.roughcountry.com)



REMOVE CONTENTS FROM BOX. VERIFY ALL PARTS ARE PRESENT.



1-800-222-7023



READ INSTRUCTIONS CAREFULLY BEFORE STARTING INSTALLATION.



3 YEAR WARRANTY

# RC-G5

### PARTS LIST OF COMPONENTS

PN	Part Description / Qty	PN	Part Description / Qty
1	Hard Folding Cover (1)	8	Front Mounting Brackets (2)
2	Left Mounting Rail (1)	9	Rear Mounting Brackets (2)
3	Right Mounting Rail (1)		
4	Mounting Bolts (10- M6 Flange Head Bolts ) & Nuts (4- 1/4-20 )		
5	Bulkhead Seal (1)		
6	Cover Retainers (x4)		
7	Drain Tubes (2)		

### Components

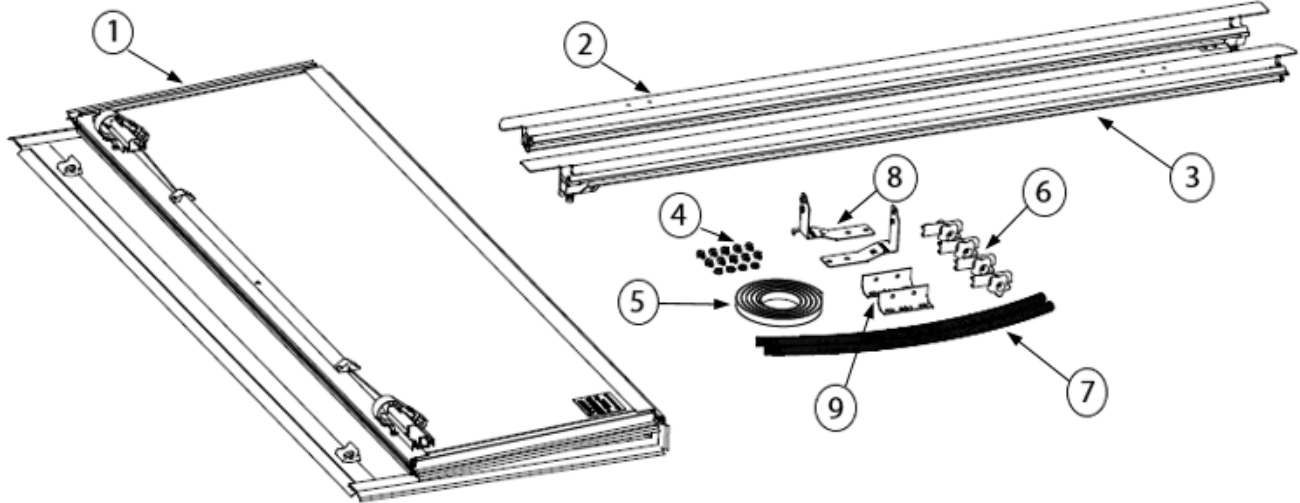

### Tools Required

Ratchet & 7/16" Socket & 10MM Wrench/ Socket

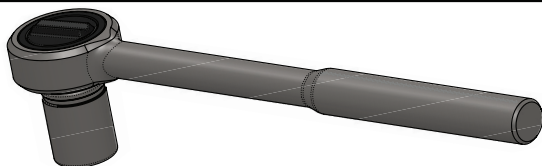

INSTALLATION PROCEDURE

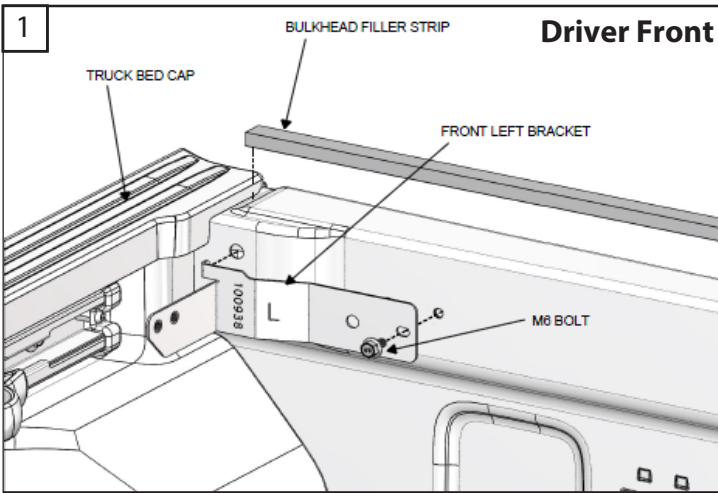

1. Install the bulkhead seal on top of the front bulkhead of the bed, centering the bulkhead seal front to back. Make sure to place the bulkhead seal, so that both ends set flush against the inside edge of the plastic bed rail caps, ( driver to passenger side ). Trim to fit.

**Note:** If your Jeep is equipped with the track system, the front track must be removed at this time to allow for the installation of the front brackets.

Next locate the driver's side front left bracket ( labeled with an L as shown in Drawing 1)( Passenger side labeled R ). Locate the pre-bent tab on the front bracket and place in the upward most hole located towards the front corner of the bulkhead on both sides. Repeat on passenger side.

**Note:** If you previously removed your front track, place the front track over the face of the 2 front brackets and reinstall front track.

Place an M-6 flange head mounting bolt through the slotted hole in the mounting bracket( same hole used for the front track ) The M-6 bolts for the front brackets ( and front track can now be tightened at this time).

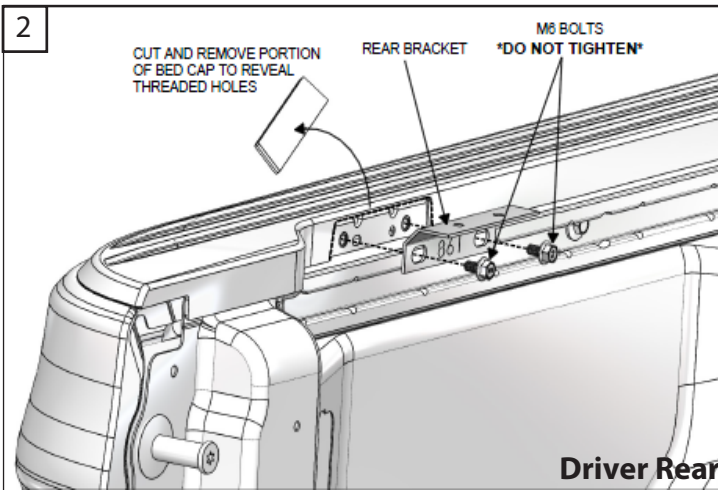

2. Locate the outlined section on the inside of the bed cap towards the tail light well at the rear of the bed. Cut and remove the outlined section of bed cap to reveal threaded holes. Repeat process for both Driver and Passenger side. Locate the 2 rear brackets and install ( as shown in Drawing 2 ), using 2 M-6 flange head mounting bolts per side. Do not tighten, leave slightly loose at this time.

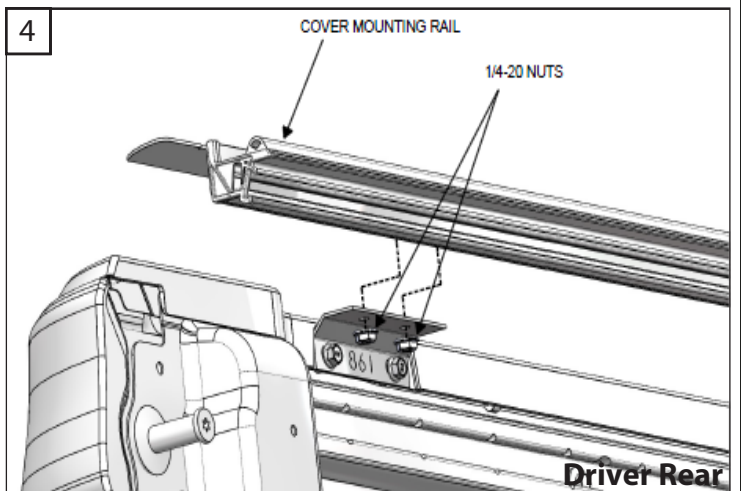
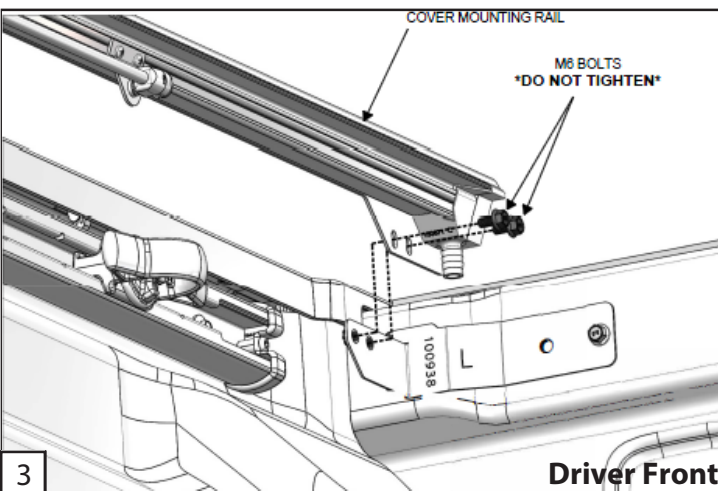

3. Locate the Driver side mounting rail. Using 2 M-6 flange head mounting bolts, install the driver side mounting rail to the driver side front bracket ( as shown in Drawing 3 ). Do not tighten, leave slightly loose until rear mounting bolts are installed. Repeat process for passenger side.

4. Install the rear portion of each mounting rail, (as shown in Drawing 4 ) Locate the 2 studs on the bottom side of the mounting rail and place the studs through the 2 holes in the rear bracket. Use 2 ( 1/4-20 ) nuts, thread on to the studs and tighten, using a 7/16" socket. Repeat process for opposite side.

5

APPLY PRESSURE WHILE TIGHTENING BOLTS TO ASSURE RAIL IS SEALED AGAINST BED CAP

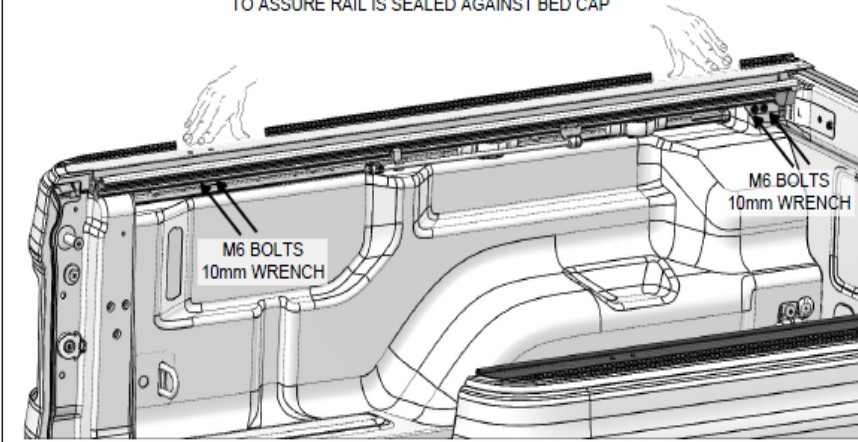

5. Once the mounting rails are in place, apply pressure while tightening the bolts to assure rails are sealed against the bed cap. ( The use of a ratchet, 10MM socket or wrench for the M-6 bolts is recommended ). The assistance of another person may be needed for this step to get the proper seal.

6



6. Set the tonneau onto the mounting rails, the buckles should be to the front.

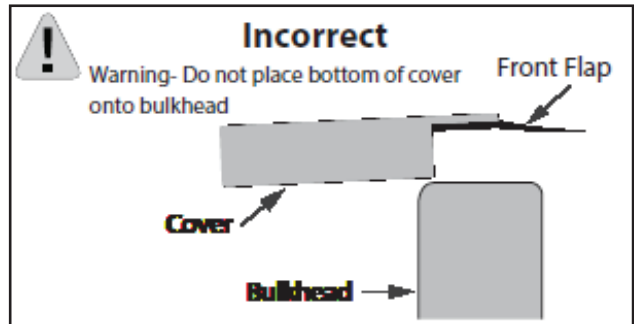
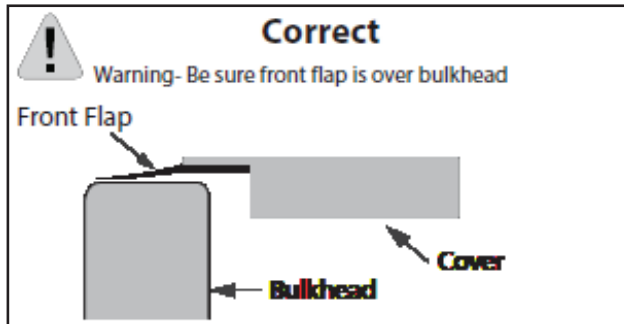



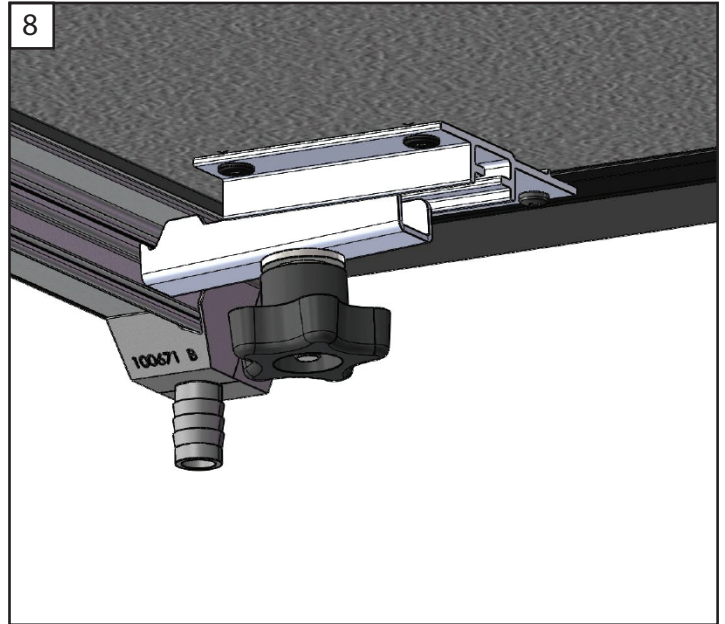
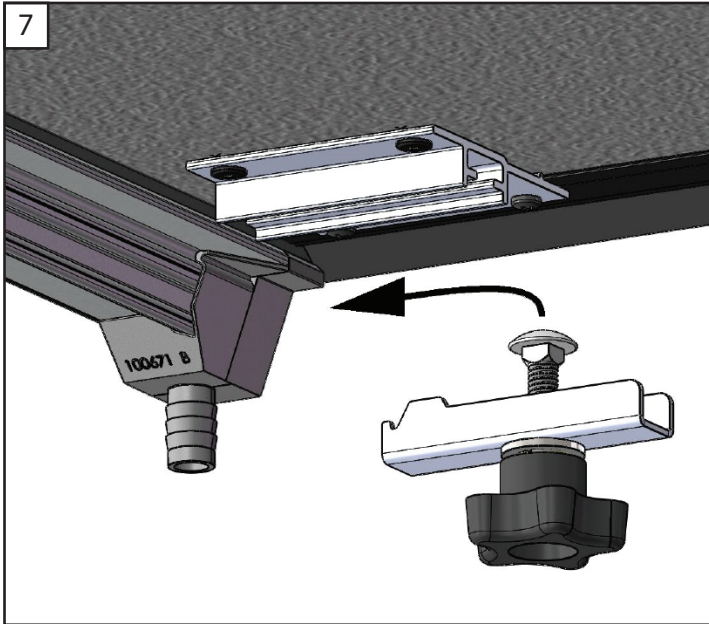

7 & 8. Assemble the four retainer clamps, slide each of them into the track on the underside of the tonneau, slide into position, but do not tighten at this time.

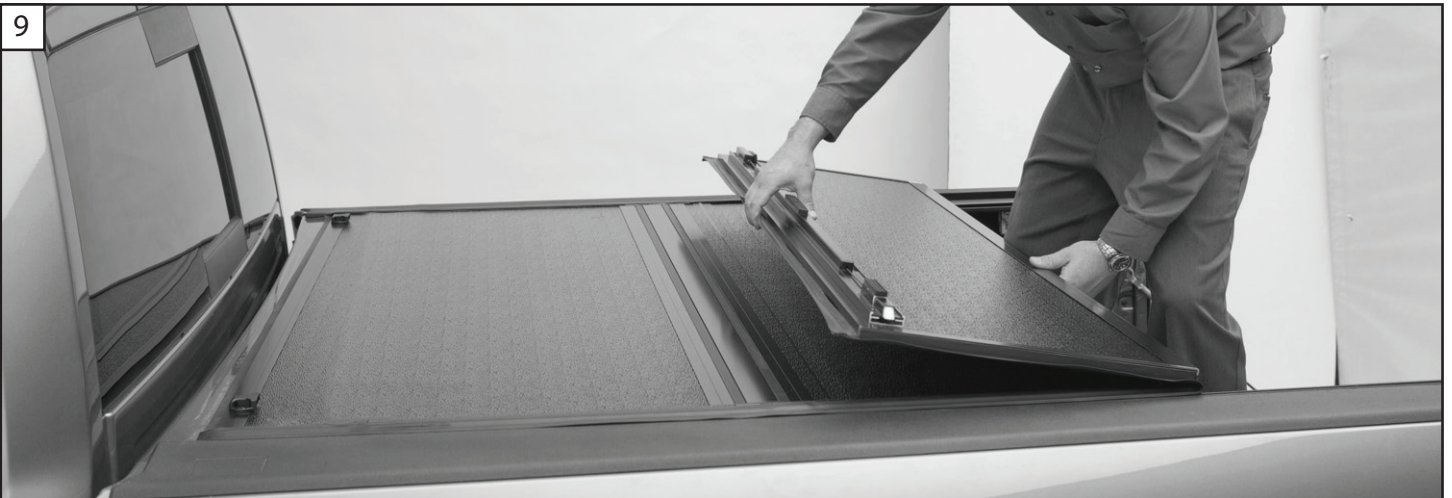

9. Carefully unfold the cover. Position the cover so it is centered side to side and front to back on the truck bed.

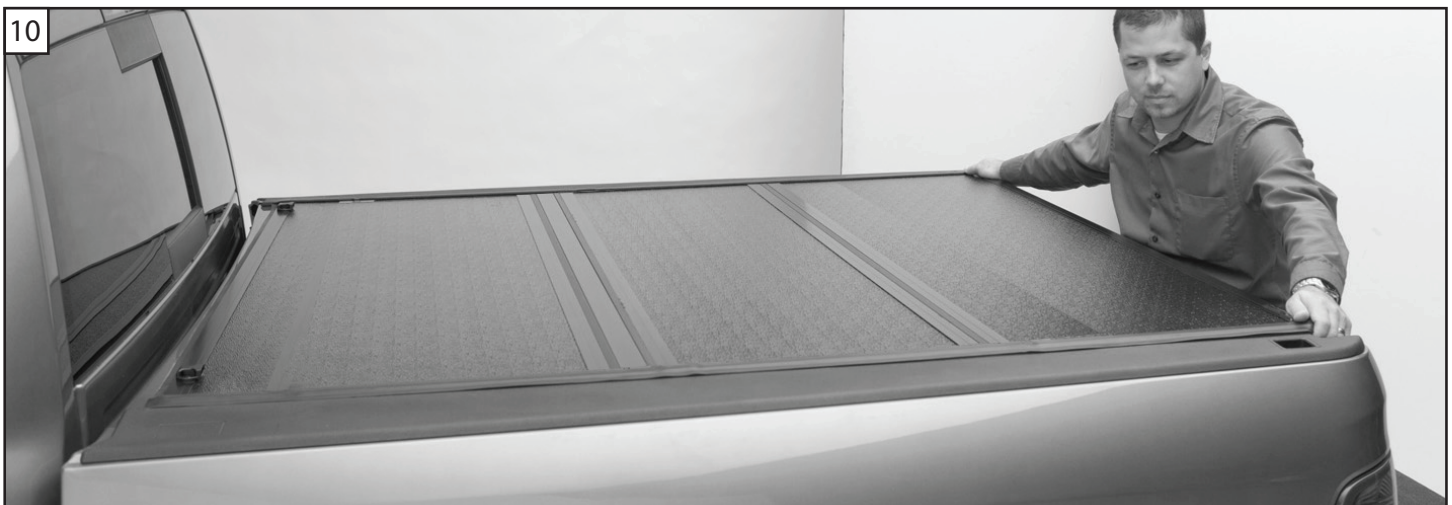

10. Test the rear latching assembly for smooth operation as this is the best indicator of the cover being positioned correctly. Be sure the latches on both sides are engaging with the cover mounting rail.  
*Note: If your truck is equipped with a tailgate protector, you may need to slightly raise the rear of the side mounting rails for the latches to engage properly.*





11 & 12. Once the cover is located correctly, fold the cover to the open position. Pull the release cables on the rear panel to release it from the side rail. Take care to fold it gently so the position of the cover is not disturbed.

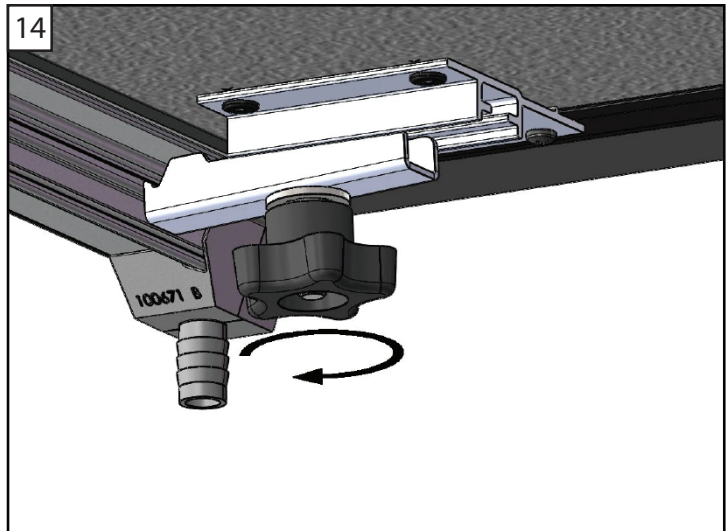
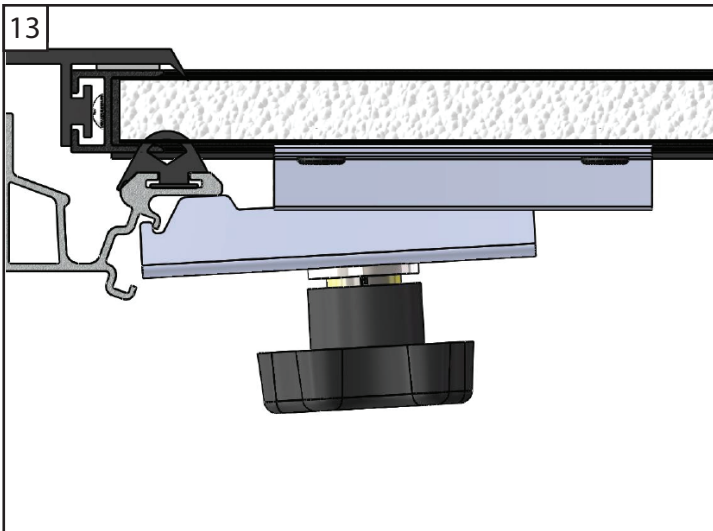

13 & 14. Once in the open position double check the clamp engagement to the side rail and tighten. Test the cover again for proper operation, adjust as needed, then tighten the star knobs.

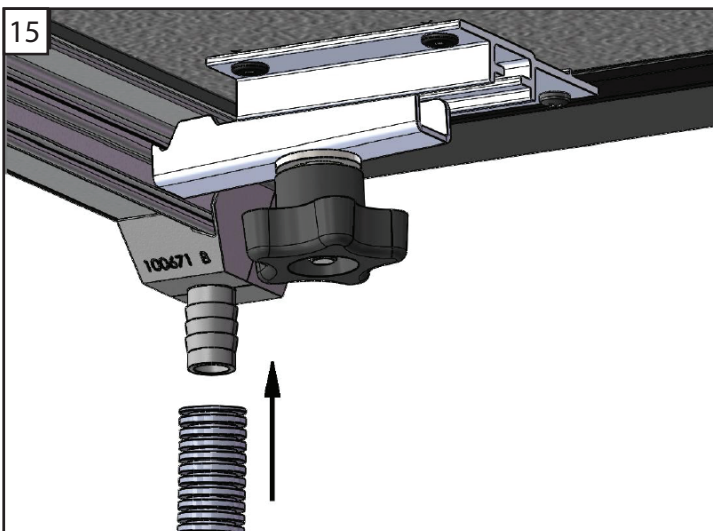

15. Attach the drain tubes to the fittings at the front of the bed rail and position the tubes to divert water out of the truck bed. This can be done by placing the tube behind a bed liner, through an existing hole in the bed, or by drilling a 5/8" hole in the bulkhead.

*Note: If you choose to place the tube behind your bedliner, be sure your drain holes in the bed are not clogged.*

*Note: If you choose to drill holes, be sure to clean up the metal shavings.*

## OPERATION INSTRUCTIONS



1 & 2. To open the cover: Lower the tailgate and pull the cable. While pulling on the cable lift the panel up and towards the cab.

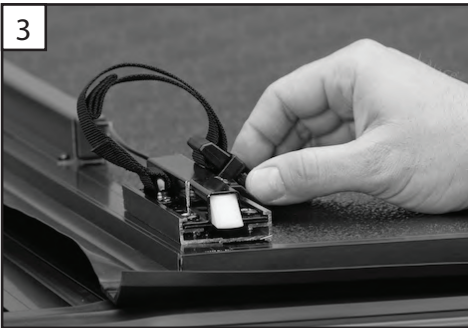

3, 4 & 5. Release the strap from the stowed position by squeezing the tabs. Attach the buckle at the bulkhead, pull the strap to take up the slack and secure the cover. Repeat this for the opposite side.

## WARRANTY COVERAGE

### Terms of Warranty

The structure of your cover is warranted to be structurally free from defects in material and workmanship for (3) three years from the retail date of purchase. The hinges, seals, and hardware are warranted to be free from defects in material and workmanship for (3) three years from the retail date of purchase. This warranty applies only to the original purchaser and is nontransferable. Your original sales receipt will serve as proof of purchase for this warranty. Before credit can be issued on a warranty claim, proof of defect may be required. This can be determined at the time of the claim.

### Exclusions of Warranty

Not covered under this warranty is failure due to neglect, improper installation including any modifications to installation hardware, alterations, addition of equipment, abuse, accident, weather related damage, exposure to chemicals that are labeled "safe for rubber" and normal wear from lack of maintenance.

### Caution

Always read the ingredients of any product you are using to clean your cover. Make sure that you only use products that are safe for use with rubber. Many chemicals contain material that will permanently discolor or damage your cover hinges and seals. This is not considered a manufacturer defect.

### Own Responsibilities

Incidental or consequential damage or loss of contents due to use, neglect, lack of maintenance, misuse or abuse of the cover is the sole responsibility of the truck owner and operator. Paint damage to your truck is not covered under this warranty. When operating your truck always keep the cover in either the fully closed and latched position, or properly bucked in the approved open position. The approved open position would be the first and second panels stacked on top of each other with the second panel still latched to the bed rail and both buckles snapped and pulled tight. Do not lean the cover up against the cab of the truck and do not operate truck with the cover in the temporary open position.

### Repair and Replacement

In the event that your cover is found to be defective under the terms of this warranty, it is at our discretion to repair or replace the defective part. All repairs must be made under our direction and we are not responsible for any transportation costs associated with warranted claim.

### Maintenance & Care

The panels of your cover require only periodic cleaning with mild car wash soap. Avoid all use of abrasive type cleaners as they may dull the finish. Some chemicals and fluids such as insect repellents, oils, solvents, and lubricants could potentially damage the rubber hinges and seals and void the warranty.

## FAQ

1. How difficult is it to install the tonneau cover?

***Installing of tonneau cover is easy, please follow the steps in installation manual carefully.***

2. How do I clean my tonneau cover?

***Wash the tonneau same as your truck. We recommend using soap and water.***

3. Will the tonneau cover scratch my paint?

***No. Please follow the installation instruction manual carefully to avoid scratching paint.***

4. Missing or Excess Hardware?

**Re-check hardware count as per the part list.**

5. Why is my tonneau cover not installing properly?

**Ensure year, make, model, cab length and bed size of your vehicle is listed in the application and installation steps are followed correctly.**