



www.fabtechmotorsports.com

**1000 BEACON STREET ~ BREA, CA 92821
714-990-8850 FAX 714-990-8854**

**1999-2002 CHEVROLET C1500
FTS1599-7 3" LIFT SPINDLES**

PARTS LIST:

- 1 EA. PASSENGER SIDE LIFT SPINDLE FTS1599-7P**
- 1 EA. DRIVER SIDE LIFT SPINDLE FTS1599-7D**
- 2 EA. 1/4" x 3/4" BOLT**
- 2 EA. 1/4" LOCK WASHER**
- 2 EA. 1/4" FLAT WASHER**
- 1 EA. PACKAGE THREAD LOCKING COMPOUND**

TOOL LIST: (NOT INCLUDED)

- FLOOR JACK**
- JACK STANDS**
- ASSORTED METRIC AND S.A.E SOCKETS, & ALLEN WRENCHES**

READ ALL INSTRUCTIONS THOROUGHLY FROM START TO FINISH BEFORE BEGINNING INSTALLATION! IF THESE INSTRUCTIONS ARE NOT PROPERLY FOLLOWED, SEVERE FRAME OR UPPER CONTROL ARM DAMAGE MAY RESULT TO THE VEHICLE.

OEM WHEELS AND TIRES CANNOT BE USED AFTER THE INSTALLATION OF THIS KIT. WE RECOMMEND AFTER MARKET WHEELS WITH A MAXIMUM BACKSPACING OF 4 5/8".

INSTRUCTIONS:

1. Jack up the front end of the truck and support the frame rails with jack stands. **NEVER WORK UNDER AN UNSUPPORTED VEHICLE!** Remove the front tires.
2. Starting on the passenger side of the truck, remove the bolt attaching the brake line tab to the spindle. Remove the two bolts securing the brake caliper bracket to the spindle, do not separate the brake caliper from the caliper bracket, and tie it up and out of the way. **DO NOT LET THE CALIPER HANG BY THE BRAKE LINE!**



3. Follow the antilock brake sensor wire from the hub to the frame rail. Separate the wire from the upper control arm and separate the connector at the frame.



- Remove the nuts securing the tie rod, upper and lower ball joints to the spindle. Separate all three joints from the spindle and remove the spindle from the control arms. Remove the three bolts securing the wheel bearing assembly to the spindle, noting the position of the hub and air deflector in the spindle for reassembly.

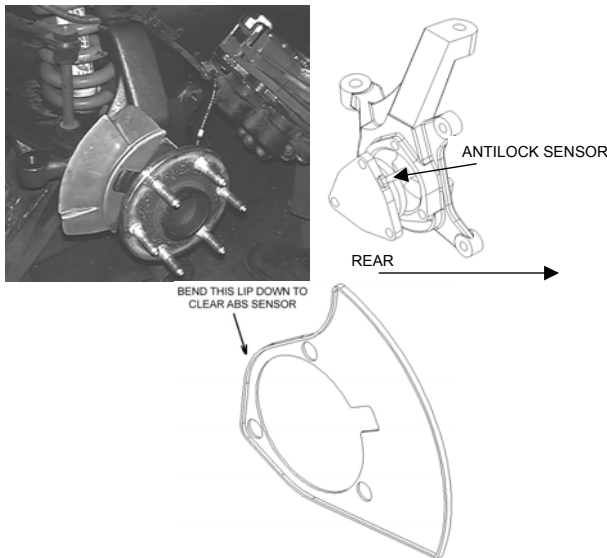

- Take the spindle marked FTS1599-7P and set it onto the lower ball joint. Tighten the nut on the lower ball joint to 94 ft/lbs. Modify the air deflector as shown above and place it with the bearing/hub assembly in the lift spindle. Using the original position of the antilock sensor as a reference, rotate the bearing/hub assembly towards the rear of the truck 120° or one bolt hole, **DO NOT CHANGE THE POSITION OF THE AIR DEFLECTOR.** The sensor should be pointing towards the rear of the truck.

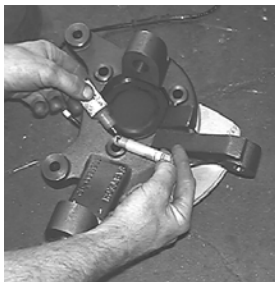

- Apply several drops of the supplied thread locking compound to the three original spindle bolts and torque to 133 ft/lbs.

CUT OUT TEMPLATE FOR PASSENGER SIDE CALIPER MOUNTING BRACKET

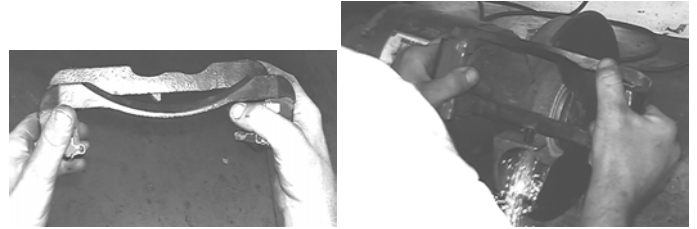
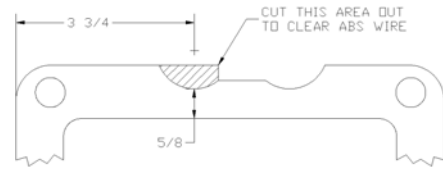

- Place the caliper and bracket assembly onto the lift spindle. **ON THE PASSENGER SIDE ONLY, YOU WILL HAVE TO CLEARANCE THE CALIPER BRACKET AS SHOWN ABOVE. A FULL SIZE TEMPLATE CAN BE FOUND ON THE LAST PAGE.**



- Apply several drops of the supplied thread locking compound to the two original bolts and torque to 129 ft/lbs. With the brake line routed behind the spindle, place the spindle onto the upper ball joint and torque the nut to 74 ft/lbs., you may need to hold the ball joint shaft with a wrench. Install the tie rod end into the steering knuckle and torque the nut to 46 ft/lbs.

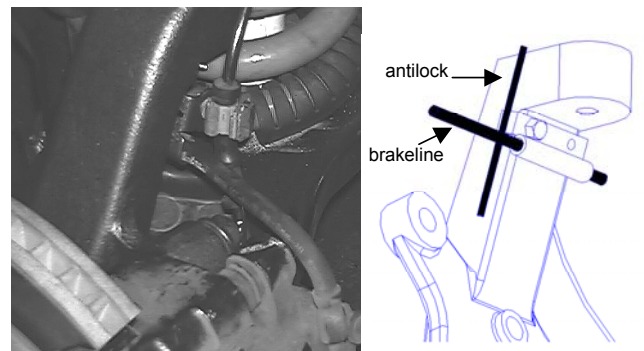

- Locate the brake line tab onto the two holes on the backside of the spindle. Using the supplied 1/4" bolt and lock washer, place one drop of the supplied thread locking compound on the threads and attach the brake line tab to the spindle. Be sure the locating tab is positioned in the adjacent hole. Torque the bolt to 5 ft/lbs.

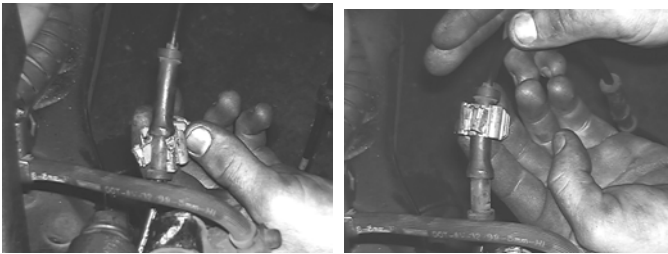

BEFORE

AFTER

10. Reattach the antilock sensor wire to the brake line tab, moving the clip to the lower portion of the wire insulator for more slack between the spindle and the frame. Also

reconnect the antilock sensor wire to the upper control arm and frame connector.

11. Repeat steps two through seven on the driver side of the truck.
12. Reinstall the front tires and torque the wheel lugs to factory specifications, located in the owners manual. Set the truck back on the ground. **WHILE TURNING THE STEERING WHEEL FULLY IN EACH DIRECTION, MAKE SURE THERE IS AMPLE CLEARANCE BETWEEN THE WHEELS, TIRES, CONTROL ARMS, BRAKE LINES AND ABS WIRES.**

RETORQUE ALL NUTS, BOLTS AND LUGS AFTER 50 MILES AND PERIODICALLY THEREAFTER.

For technical assistance call: 714-990-8850

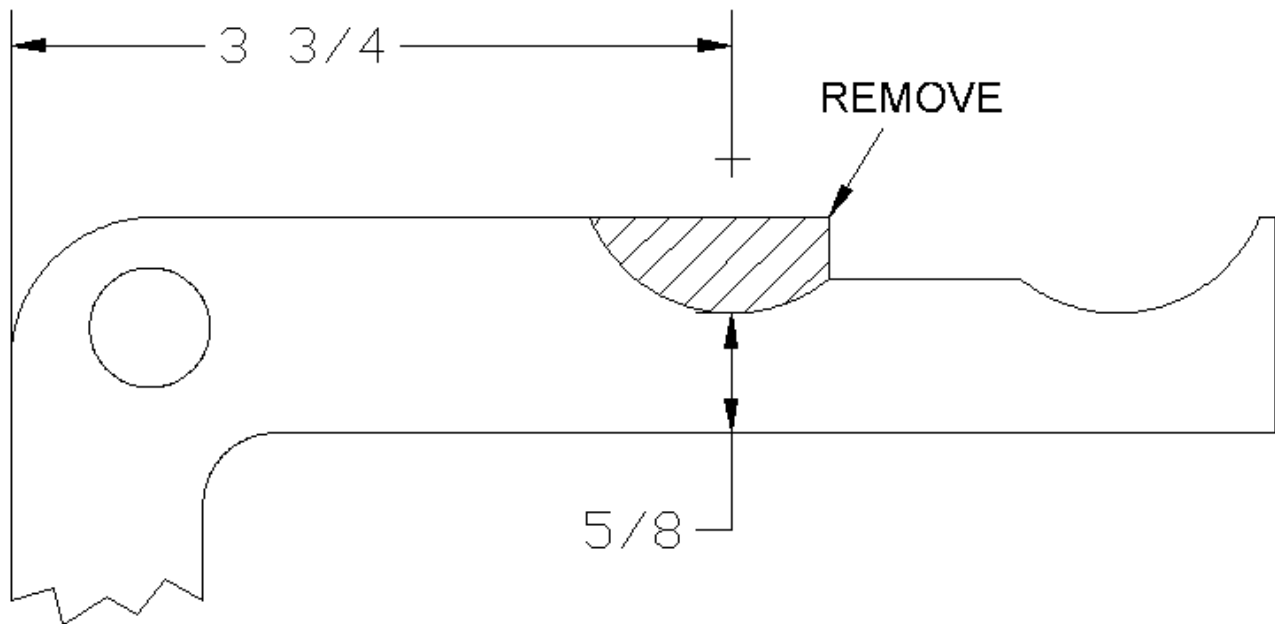

RETORQUE ALL NUTS, BOLTS AND LUGS AFTER 50 MILES AND PERIODICALLY THEREAFTER.

For technical assistance call: 714-990-8850

Fabtech Motorsports Suspension Products

Fabtech Motorsports warrants to the original retail purchaser who owns the vehicle on which the product was originally installed. Fabtech Motorsports does not warrant the product for finish, alterations, modifications and/or installation contrary to Fabtech Motorsports' instructions. Fabtech Motorsports suspension products are not designed nor intended to be installed on vehicles used in race applications or for racing purposes or for similar activities. (A "RACE" is defined as any contest between two or more vehicles, or any contest of one or more vehicle against the clock, whether or not such contest is for a prize). This warranty does not include coverage for police or taxi vehicles, race vehicles, or vehicles used for government or commercial purposes. Also excluded from this warranty are sales outside of the United States of America. Fabtech suspension products that increase the vehicle's ride height may greatly increase the risk of vehicle roll over. Vehicles should be operated in a safe manner at all times as not to cause a roll over or an accident resulting in injury or death. Fabtech Motorsports' obligation under this warranty is limited to the repair or replacement, at Fabtech Motorsports option of the defective product. Any and all costs of removal, installation or re-installation, freight charges, incidental or consequential damages are expressly excluded from this warranty. This warranty is expressly in lieu of all other warranties expressed or implied. This warranty shall not apply to any product that has been subject to accident, negligence, alteration, abuse or misuse. Fabtech Motorsports does not warrant products not manufactured by Fabtech Motorsports. Please see Fabtech's Jobber Price Sheet for additional conditions and warnings.