



RD201

NISSAN C200, 31 SPLINE

**AIR OPERATED
LOCKING DIFFERENTIAL
INSTALLATION GUIDE**

No liability is assumed for damages resulting in the use of the information contained herein.
ARB Air Locker Locking Differentials and Air Locker are trademarks of ARB Corporation Limited.
Other product names used herein are for identification purposes only and may be trademarks of their respective owners.

ARB 4x4 ACCESSORIES

Corporate Head Office

**42-44 Garden St
Kilsyth, Victoria
AUSTRALIA
3137**

Tel: +61 (3) 9761 6622

Fax: +61 (3) 9761 6807

Australian enquiries

North and South American enquiries

Other international enquiries

sales@arb.com.au

sales@arb.com.au

exports@arb.com.au

www.arb.com.au

Table of Contents:

1	Introduction	3
1.1	Pre-Installation Preparation	3
1.2	Tool-Kit Recommendations	4
2	Removing the Existing Differential	5
2.1	Vehicle Support	5
2.2	Differential Fluid Drain	5
2.3	Removing the Axles	5
2.4	Marking the Bearing Caps	6
2.5	Checking the Current Backlash Amount	7
2.6	Spreading the Differential Housing	8
2.7	Use of the Thrust Block	9
3	Bench Measurement	10
3.1	Measurement for Pre-Load Shimming	10
3.2	Calculation & Selection of Shims	12
4	Installing the Air Locker	13
4.1	Ensuring Adequate Oil Drainage	13
4.2	Installing the Carrier Bearings	16
4.3	Mounting the Ring Gear	17
4.4	Drilling & Tapping the Bulkhead Port	18
4.5	Assembling the Differential Carrier	19
4.6	Modifying the Bearing Cap	21
4.7	Air Locker Final Assembly	25
4.8	Final Backlash Checking	25
4.9	Profiling the Seal Housing Tube	27
4.10	Setting Up the Bulkhead Fitting	28
4.11	Bench Testing the Air Locker	29
4.12	Reinstalling the Axles	30
5	Installing the Air System	31
5.1	Mounting the Solenoid	31
5.2	Running & Securing the Air Line	33
5.3	Connection to the Bulkhead Fitting	34
6	Mounting & Connecting the Electrical System	36
6.1	Mounting the Actuator Switch(es)	36
6.2	Wiring the Actuator System	37
7	Testing & Final Assembly	41
7.1	Leak Testing	41
7.2	Testing the Air Locker Actuation	41
7.3	Re-Sealing & Filling the Differential	42
7.4	Post-Installation Check List	43
8	Parts List	45
8.1	Exploded Assembly Diagram	45
8.2	Specifications	45
8.3	Itemized Parts List	46



1 Introduction

IMPORTANT :

BEFORE ATTEMPTING TO DISMANTLE YOUR VEHICLE FOR THIS INSTALLATION, PLEASE READ THIS INSTALLATION GUIDE IN ITS ENTIRETY, AS WELL AS ALL APPLICABLE SECTIONS OF YOUR VEHICLE MANUFACTURER'S SERVICE MANUAL.

1.1 Pre-Installation Preparation

This booklet is to be used in conjunction with your vehicle manufacturer's service manual. ARB endeavors to account for every possible variation in vehicle model when publishing its installation guides, and guides are updated regularly as new model information becomes available, however, the rapid and globally varied release of some vehicles makes it difficult to insure that your vehicle model has been accurately accounted for. In the case of any technical discrepancies between this guide and your service manual, we strongly advise that you adhere to the specifications and techniques as documented in your service manual.

Although your *ARB Air Locker* comes complete with all the step by step instructions you will need to supplement your vehicle manufacturer's service manual and install your new differential, ARB recommends that you have your *Air Locker* installed by a trained professional. Many ARB distributors around the world have been fully instructed in *Air Locker* installations by ARB, and have gained a wealth of experience and skill from years of performing similar installations.

Once you begin this installation your vehicle will be immobile until all steps of the installation are complete. Make sure your *Air Locker* kit is the correct model for your vehicle and that it contains all of the parts listed on back cover of this booklet. Also be sure you have appropriately equipped yourself with all the necessary tools, parts, and materials to complete this installation (see section 1.2 *Tool-Kit Recommendations*), and that you have allowed for an appropriate amount of vehicle down time.

HINT :

Place a ✓ mark inside each of the symbols as you complete each step. It is very important NOT to miss any of the steps!



1 Introduction

1.2 Tool-Kit Recommendations

Below is a list of tools and supplies you may need to complete this installation. Requirements for your vehicle may vary. Please consult your vehicle service manual for additional recommendations.

1.2.1 Tools

- Standard automotive sizes (metric and/or imperial) of sockets, wrenches, Allan keys, and drills.
- A dial indicator or other suitable measuring tool for checking ring & pinion backlash.
- Automotive brake tubing cutters to cut the steel tubing.
- A razor knife to cut the nylon tubing.
- A differential housing spreader, to facilitate removal and installation of the carrier. (e.g. ARB Spreader #0770003)
- A torque wrench. (See vehicle manual for required torque range.)
- A lubricant drain reservoir.
- Suitable measuring tools to measure a differential for pre-load and/or backlash shimming. (e.g. an automotive feeler gauge. See Section 3 *Bench Measurement*)
- An 11.2mm [7/16"] drill and ¼" NPT tap for bulkhead fitting installation.
- An automotive bearing puller (e.g. ARB Bearing Puller #0770001) or a differential carrier bearing puller.
- A bearing press or arbor press.
- A suitable shim driver (e.g. ARB Shim Driver #0770004)

1.2.2 Supplies

- Thread lubricant/sealant compound for pressure fittings (e.g., LOCTITE #567 or Teflon Paste)
- Thread locking compound (e.g., LOCTITE #272)
- A replacement gasket or gasket sealant, for your differential cover.
- A sufficient volume of differential oil to completely refill your housing. (see the *ARB Air Locker Operating and Service Manual* for recommended lubricants)
- A soap and water mixture to test for air leaks.
- A selection of differential bearing shims to set-up pre-load and backlash. (See section 3 *Bench Measurement*)

2 Removing the Existing Differential

2.1 Vehicle Support

- Safely secure the vehicle on a hoist. We recommend supporting the vehicle on a chassis hoist to keep the differential area at a convenient working height and to leave the wheels and axles free to be rotated and removed.
- Once supported off the ground, release the parking brake and leave the vehicle in neutral. Chock the wheels if necessary.

2.2 Differential Fluid Drain

- Clean around the differential cover plate seal to prevent dirt from entering the differential.
- Position a fluid drain reservoir under the differential.
- Remove the differential drain plug and completely drain all differential fluid.
- Once drained, reinstall the drain plug finger tight to prevent drips coming out of the housing and dust getting in.

HINT : This is a good time to check for metal particles in your oil and in the bottom of the housing which may indicate a worn bearing or differential component.

2.3 Removing the Axles

- Remove the axles as indicated in your vehicle manufacturer's service manual.

IMPORTANT :

Collision damage or heavy off-road use of your vehicle in the past may have resulted in some degree of bending in the axle. Any misalignment of the axle tubes may result in excessive wear and/or failure of your differential and axle shafts. ARB strongly recommends that you have your axle assembly inspected for concentricity and straightness before installing your *Air Locker*.

2 Removing the Existing Differential

2.4 Marking the Bearing Caps

- Using a pointed center punch, gently mark the bearing caps in a way that will enable you to know which cap is 'LEFT' and which cap is 'RIGHT', which way is 'UP' and which way is 'DOWN'. (Fig.1.)

HINT : Many installers choose to make one punch mark on the left hand side of the left hand bearing cap and one similar punch mark on the housing at close proximity to the cap mark. The right hand side is then designated with two punch marks on the right hand side of the cap and two similar punch marks on the housing.



2 Removing the Existing Differential

2.5 Checking the Current Backlash Amount

IMPORTANT:

This step is a precautionary measure recommended by ARB due to the fact that some aftermarket ring and pinion sets have been manufactured to run with different backlash settings than those specified by your vehicle manufacturer. Although ARB must recommend you set backlash according to your service manual guidelines, we also advise that you compare the backlash measurements taken here to the recommended backlash settings in your vehicle service manual. Measurements found to be outside of your service manual recommendations may indicate the need to deviate from those settings in order to achieve quiet running with a good contact mark.

Refer to your vehicle service manual or your local authorized ARB installer for more information.

- Set a depth indicator on one of the ring gear teeth as in figure 2.



- While supporting the pinion gear by holding the drive shaft, rotate the differential in both directions while observing the maximum variation in depth from the indicator (i.e., the highest value minus the lowest value). This value is referred to as the ring and pinion backlash.
- Rotate the differential center 90° and measure again for accuracy.
- Record the average of all measurements.

2 Removing the Existing Differential

2.6 Spreading the Differential Housing

IMPORTANT:

Spreading the differential housing with a differential case spreader is a step which is critical to set up bearing pre-load when a differential is installed. Improper pre-load will result in undue bearing wear, increased stresses in the differential center, increased running noise, and ultimately, ring and pinion gear damage.

- Unbolt and remove the bearing caps from the differential housing.

HINT : Be sure not to mix up the left and right hand bearing caps. Later it will be necessary to know which cup came from which bearing and which shim came from which side.

- Carefully spread the housing (Fig.3.) enough to remove the differential center. (Refer to your vehicle's service manual).

NOTE : Do not spread the housing more than 0.50mm [0.020"].

- Once the housing has been adequately spread, the differential may be removed by pulling forward on the differential carrier.

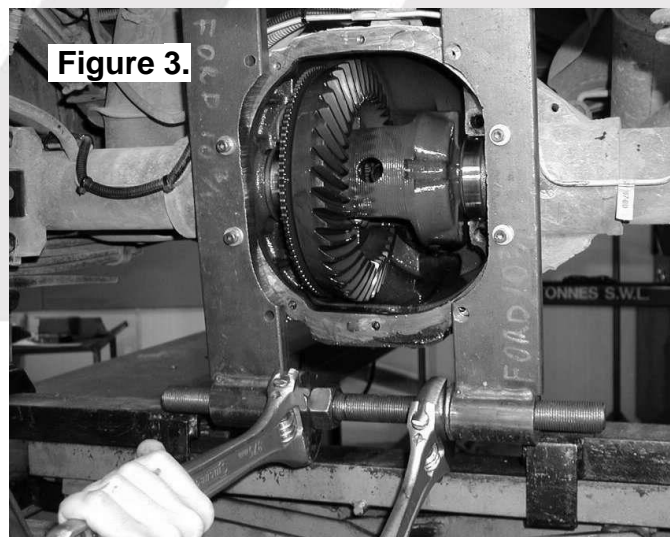

NOTE : Keep the shims separated so that they can be identified as to which end of the differential they came from.

- Release all spreader tension immediately after removing the differential carrier.

2 Removing the Existing Differential

2.7 Use of the Thrust Block

IMPORTANT:

This model of *Air Locker* was manufactured to replace Nissan differentials which employ either of the two distinctly different methods of retaining the axle shafts.

- 1 Full Floating Axles
- 2 Semi-Floating Axles

Depending on which axle type you have, you may be required to install the thrust block included with the *Air Locker* kit before final assembly.

4.3.1 Full Floating Axles

Full-floating axles are completely supported and therefore do not require a thrust block at all.

4.3.2 Semi-Floating Axles

Semi-floating axles are only retained inward at the wheel end of the axle shaft and are supported in the center of the axle assembly by a thrust block. You can easily identify this by looking through the axle splines of your original differential carrier to see if a thrust block was used.

If this is the case then you will have to insert the thrust block (supplied with the *Air Locker* kit) into the differential center just before inserting the *Air Locker* into the axle housing.

HINT : A wad of thick grease on the thrust block should keep it from sliding around during installation.

3 Bench Measurement

3.1 Measurement for Pre-Load Shimming

When fitting an ARB *Air Locker*, a master shim and a variable shim pack (supplied) are used in conjunction with the original bearing on the left hand side of the differential (as pictured in Fig.12.) in order to achieve the correct ring and pinion backlash and carrier bearing pre-load once the *Air Locker* has been installed.

The original bearing type and shim type are used on the right hand (case) side of the Air Locker (as pictured in Fig.5.). Measurements will, however, need to be taken to determine the correct shim thickness for this side in order to reproduce a similar backlash and pre-load to that of your existing differential.

The large spacer on the outside of the ring gear side shim must not be used again when the Air Locker is installed.

NOTE : Keep the shims separated so that they can be identified as to which end of the differential they came from.

- Secure the differential to a work bench.
- Remove the bolts that hold the ring gear in place.
- Using a plastic or copper hammer, tap in a circle around the ring gear to separate it from the differential carrier.
- Remove the original bearings from the differential center using a bearing puller.
- Using a caliper or similarly accurate measurement method (i.e., able to take accurate measurements within 0.04mm [0.0015"]), measure the distance from the shoulder of the bearing journal to the ring gear mounting face (shown as 'A' in Figure 4.) and record this measurement as 'A'.
- Measure the thickness of the OE master shim removed from the case side of the differential carrier (shown as 'B' in Figure 4.) and record this measurement as 'B'.
- Measure the distance from the *Air Locker* bearing shoulder to the ring gear mounting face (shown as 'C' in Figure 5.) and record this measurement as 'C'.

3 Bench Measurement

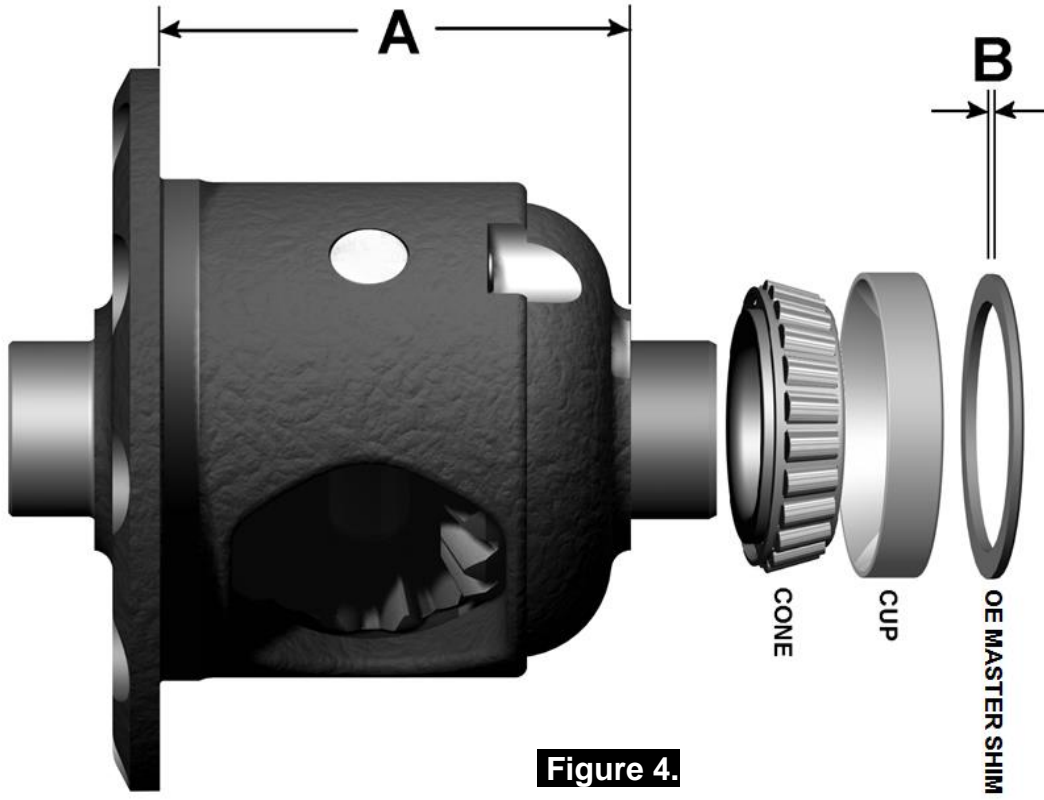

Figure 4.

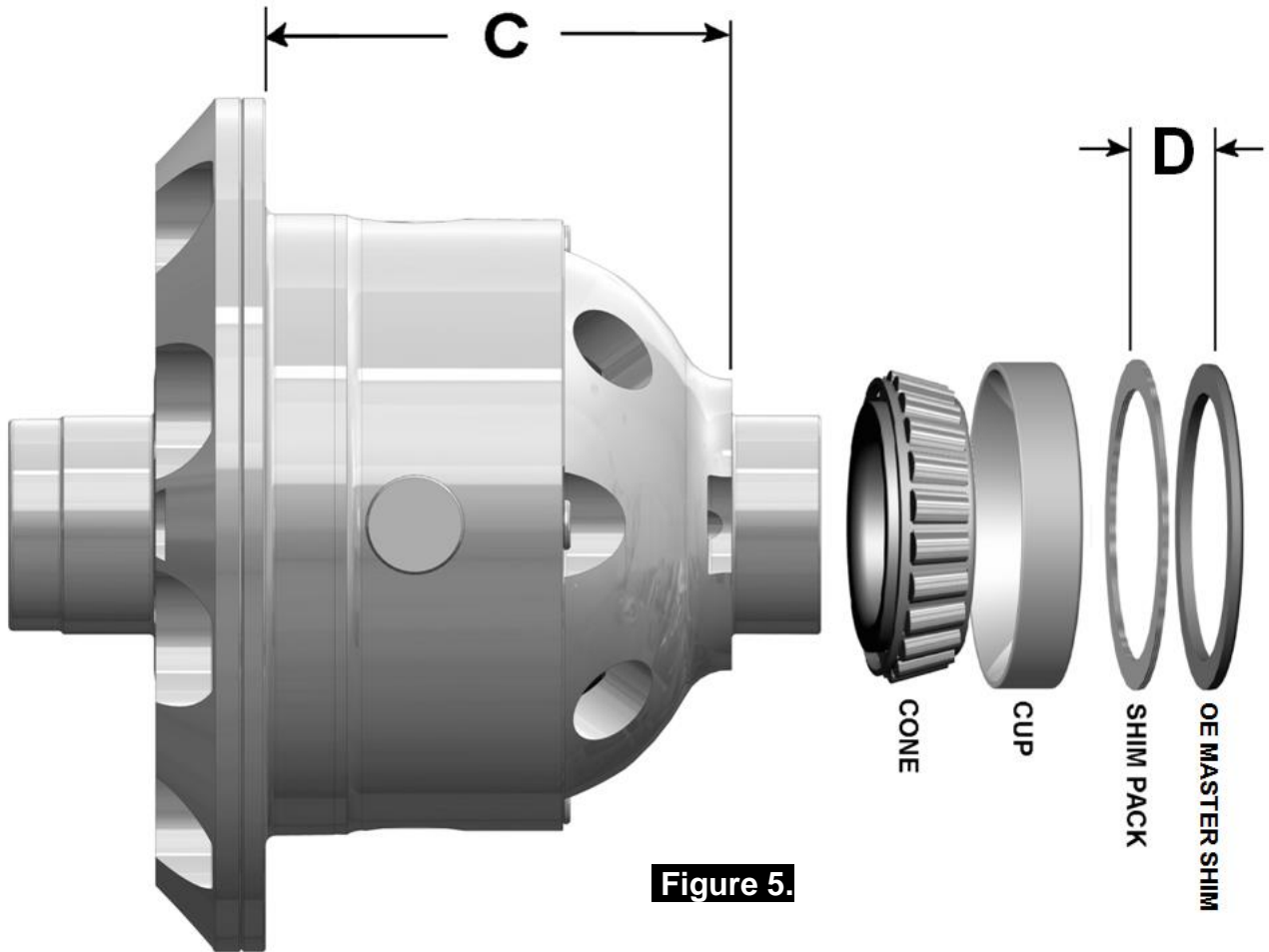

Figure 5.

3 Bench Measurement

3.2 Calculation & Selection of Shims

The thickness of the shim pack required for the *Air Locker* (shown as 'D' in Figure 5.) can now be determined by substituting the measurements taken into the following equation.

$$A + B - C = D$$

HINT : If your calculations are correct then the following equation will also be true:

$$A + B - C - D = \text{ZERO}$$

To make a shim pack to match the measurement you calculated as 'D' you can:

- Use shims from the supplied shim kit.
- Purchase a new shim kit from your Nissan dealer.
- Use a universal shim kit available from most drive train specialists.

NOTE : Never re-use any shims which are damaged or worn.

4 Installing the Air Locker

4.1 Ensuring Adequate Oil Drainage

IMPORTANT:

Some axles were manufactured with poor oil drainage between the axle tubes and the differential housing. This can often result in one of the axle tubes filling up with differential oil while running. In most cases this will result in a blocked air vent which will cause the differential housing to pressurize and expel oil from the axle seals at the wheels or force oil into the air system of the *Air Locker*, eventually expelling oil at the solenoid valve. This is a design flaw which was corrected by most automakers in the later releases of their axle assemblies. If no lower drainage points are present in the differential housing then it is critical that you modify the housing to include them.

- Inspect the differential housing for the presence of adequate drainage in both axle tubes (refer to Fig.6.).

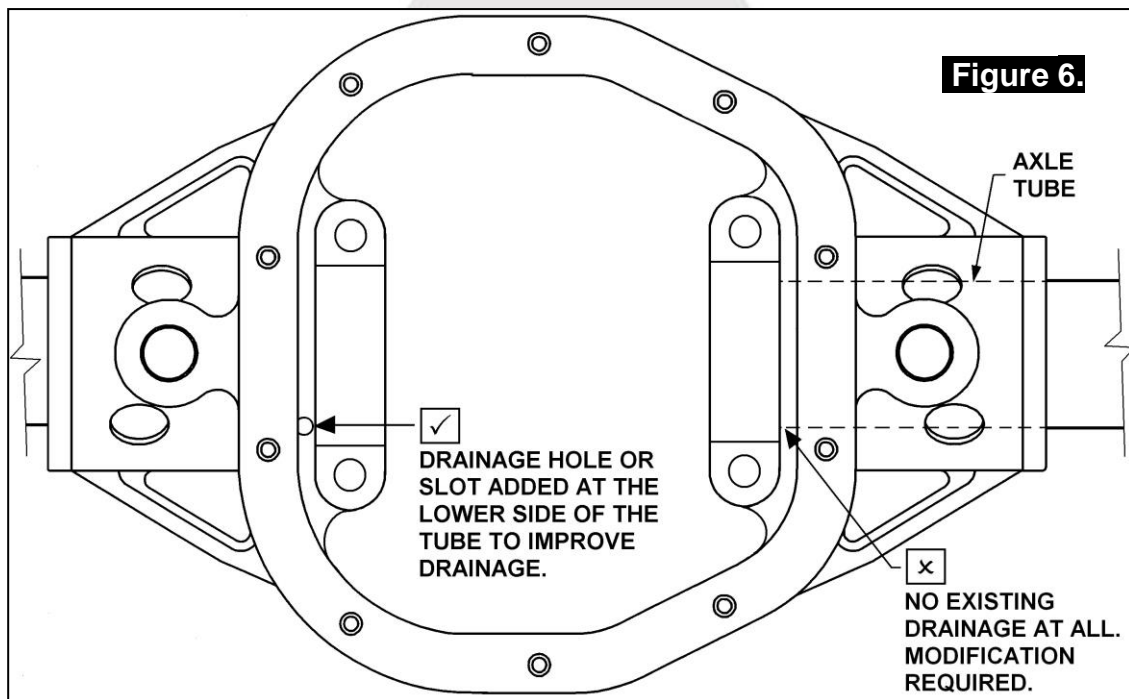

- If no drainage exists then two slots should be created in the bearing seat face of both axle tubes; one on the upper side of the tube, and one on the lower side. Figure 7. shows an example of an axle housing with no existing oil drainage.

4 Installing the Air Locker

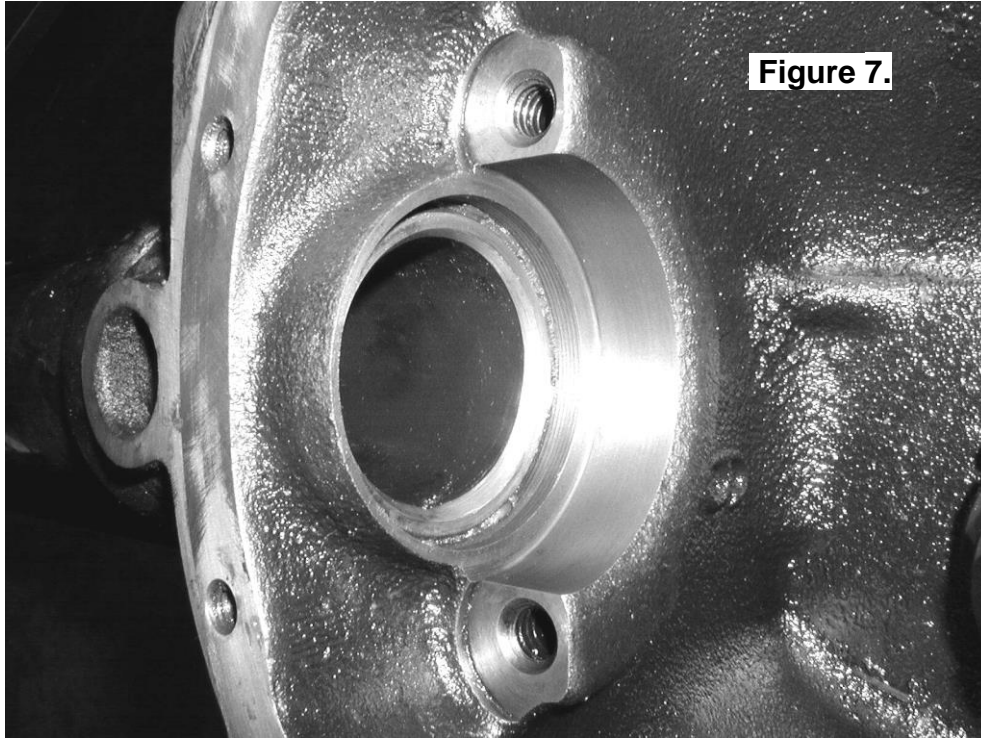

NOTE : Cover the differential housing cavity and the axle tube openings with a rag to protect them from metal filings.

4 Installing the Air Locker

- If drainage exists but is inadequate then slots or holes should be cut into the housing on the upper and lower side of the tubes where required.

NOTE : Figure 9. shows upper and lower drainage slots cut into a bearing seat which had no existing drainage at all before modification.

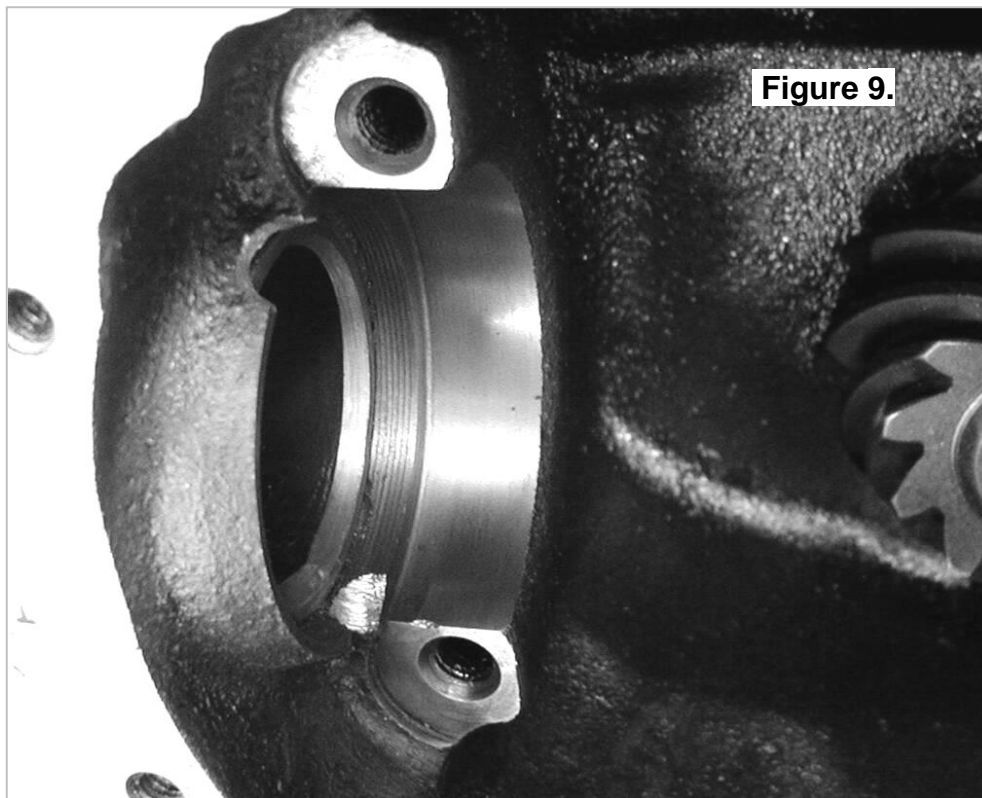

- Remove any sharp edges left behind by the modifications that could break off and fall into the cavity.
- Make sure any grinding dust, filings or drill chips left behind by cutting the drainage slots are completely cleaned out of the housing.
- Check that the axle air vents are clear and working correctly.

4 Installing the Air Locker

4.2 Installing the Carrier Bearings

- With the *Air Locker* well supported in an arbor press, apply a thin film of high pressure grease to the case side bearing journal.
- Press the tapered roller bearing cone onto the bearing journal of the differential carrier.

NOTE : Never re-use any bearings which are damaged or worn.

- Invert the *Air Locker* and apply a thin film of high pressure grease to the seal housing side bearing journal.
- Press the second bearing cone onto the opposite bearing journal. (Figure 10.)

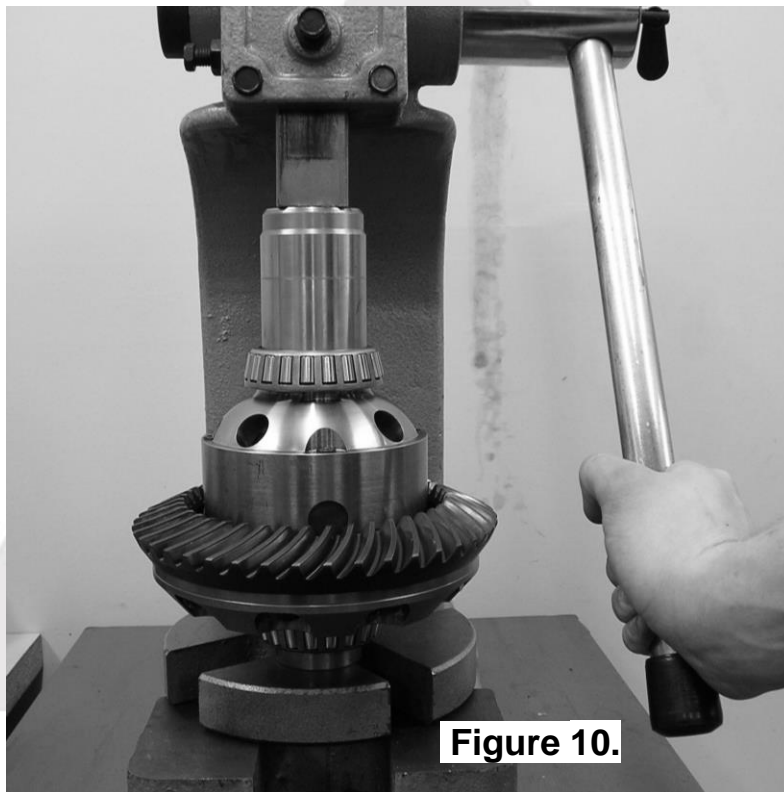

NOTE : Do not add any shims between the seal housing bearing and the bearing seat.

4 Installing the Air Locker

4.3 Mounting the Ring Gear

IMPORTANT:

Your *Air Locker* was manufactured to replace differentials using 12mm [0.472"] diameter ring gear bolts. Ring gears with smaller bolts should **ONLY** be installed using cylindrical spacers to reduce the clearance between the bolts and the *Air Locker* flange.
(not supplied)

- Apply a thin film of high-pressure grease to the ring gear shoulder of the *Air Locker* to prevent seizing.
- Thoroughly clean any thread locking compound or other foreign matter from the holes of the ring gear, the threads of the ring gear bolts, and the mating surfaces of the ring gear and the *Air Locker* flange.

NOTE : Rubbing the ring gear mounting face with a flat oil stone before installation will remove any high spots around the threads.

- Heat the ring gear to between 80 and 100°C (175 - 212°F) in an oven or in hot water to slightly expand the gear and facilitate assembly.

NOTE : **NEVER HEAT GEARS WITH A FLAME!** This could damage the hardened surface of the gear and result in premature wear or failure.

- Dry the ring gear with compressed air (if wet), paying particular attention to the threaded holes.
- Install the ring gear onto the *Air Locker* by aligning the holes in the flange with the tapped holes in the ring gear, then gently tapping it around in a circle with a plastic or copper hammer.

NOTE : Avoid using the bolts to pull down the ring gear as this puts excess strain on the bolts and the differential flange.

- Apply a thread locking compound to the thread of each ring gear bolt before inserting it.

NOTE : Do not apply threading compound directly into the threaded hole as this could prevent the bolt from reaching its full depth.

- Tighten the ring gear bolts in a star pattern with a torque wrench according to your vehicle manufacturer's specified torque.

4 Installing the Air Locker

4.4 Drilling and Tapping the Bulkhead Port

A port must be drilled and tapped through the differential housing to allow the seal housing tube through the housing to connect with the air line from the air compressor.

- Mark a spot for the bulkhead port on the right hand side toward the top of the differential housing that is in an area that will be well clear of the ring gear, the differential, and any other obstructions that may snag the seal housing tube.
- Cover the drive pinion and axle tube areas with a rag to protect them from metal filings.



- Drill through the housing square to the outside surface using an 11.2mm [7/16"] drill. (Fig.11.)
- Tap the hole from the outside using a 1/4" NPT tapered pipe thread tap.
- Remove any sharp edges from the hole that may chip-off and fall into the housing.
- Very carefully remove rags and inspect with a service light inside the housing to insure no metal filings are left behind.

4 Installing the Air Locker

4.5 Assembling the Differential Carrier

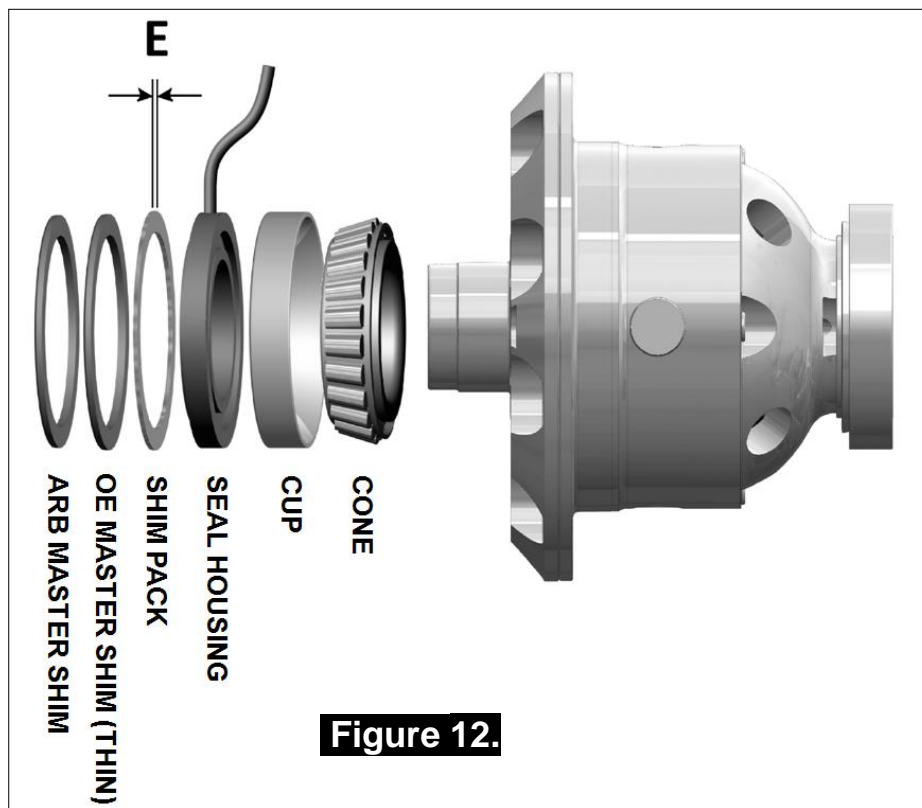

- Clean all parts of the differential assembly. It is very important to make sure the bearings, seal housing internal walls and the shims surfaces are free from any contaminants (e.g. water, dirt, metal fillings etc.)
- Place the bearing cup over the bearing cone (Figure 12.).
- Generously lubricate the O-rings with oil prior to assembly, then insert them into the grooves of the seal housing.
- With a slight twisting motion, carefully slide the seal housing all the way onto the bearing journal. Install the OE master shim onto the seal housing.
- There should be two OE master shims on the LHS, measuring approximately 8mm and 2.3mm respectively. Discard the thicker shim but keep the thinner shim in use.

NOTE : The shim pack cannot be installed at this time as the required thickness (shown as 'E' in Figure 12.) has yet to be determined.

- Hold the bearing cup in place on the case side.
- Hold the ARB master shim, OE thin master shim, seal housing and bearing cup on the ring gear side. Then insert the *Air Locker* assembly into the differential housing with the seal housing tube pointing straight out of the housing.

4 Installing the Air Locker

- Install one bearing cap on the case side. The bearing cap on the seal housing side will need to be drilled or slotted as clearance for the seal housing tube.
- Install the bearing cap bolts finger tight.
- Push the *Air Locker* hard across to the case side, and measure the gap (end float) between the master shim and the housing with a feeler gauge.
- Consult your vehicle manufacturer's service manual to determine the carrier bearing pre-load amount specified for your vehicle.
- Add the specified pre-load amount to the measurement taken with the feeler gauge to determine a shim amount for 'E' in Figure 12.

PRE-LOAD + END FLOAT = SHIM PACK

- Select suitable shims from the supplied shim kit to make up a shim pack of this thickness and leave it aside for final assembly.

IMPORTANT:

When installing the Air Locker into the housing, it is critical to check for clearance between the Air Locker case and the pinion gear. The pinion head is very large and runs very close to the Air Locker. Any less than 1mm of clearance should be considered inadequate, and the pinion will have to be removed from the housing and the corners ground to create adequate clearance (See Figure 13.). Modifying the pinion gear in this way does not weaken the pinion at all.

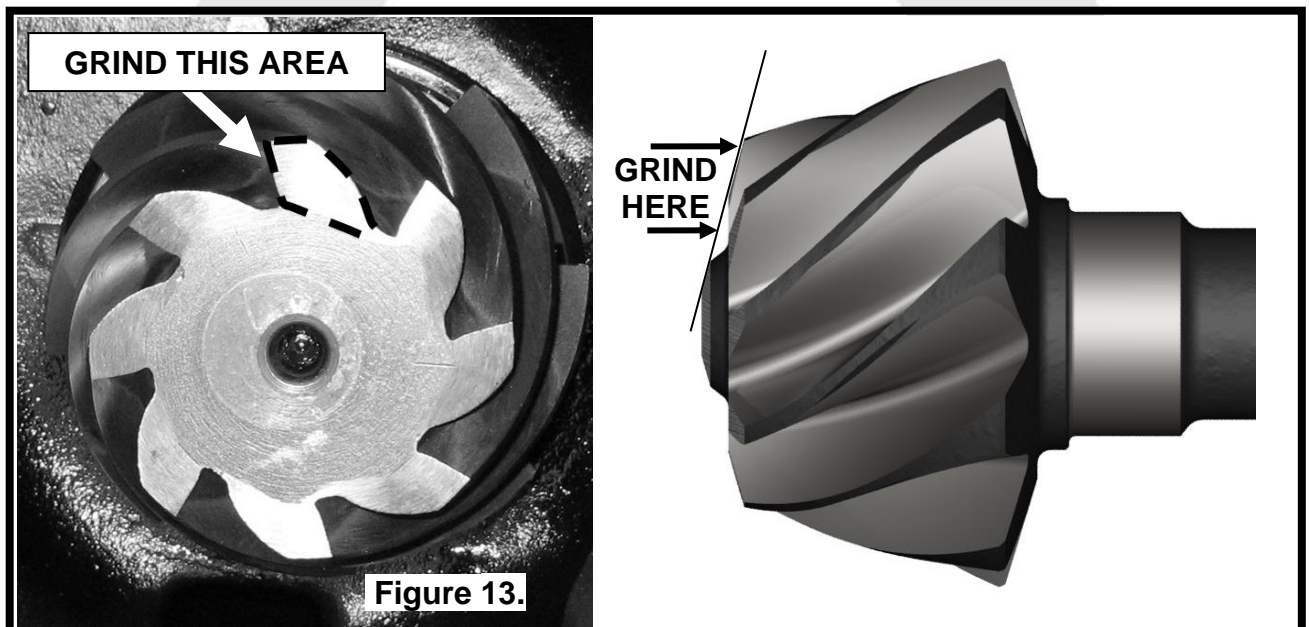

4 Installing the Air Locker

4.6 Modifying the Bearing Cap

Clearance for the seal housing tube must be made in the bearing cap.

4.6.1 Marking the Tube Position

- Without using a spreader, fill the gap (end float) between the master shim and the seal housing with a reasonable thickness of shims.
- Ensure the *Air Locker* is securely fitted in place and there is no significant movement when you push it left and right.
- An accurate measurement for the seal housing tube clearance can now be made.

NOTE : Take time and double check when taking your measurements, as bearing caps are custom fitted to the axle housing and cannot be replaced.

- With the seal housing tube pointing straight out, measure the distance from a fixed position inside the differential housing to the center of the seal housing tube. (Fig.14.)

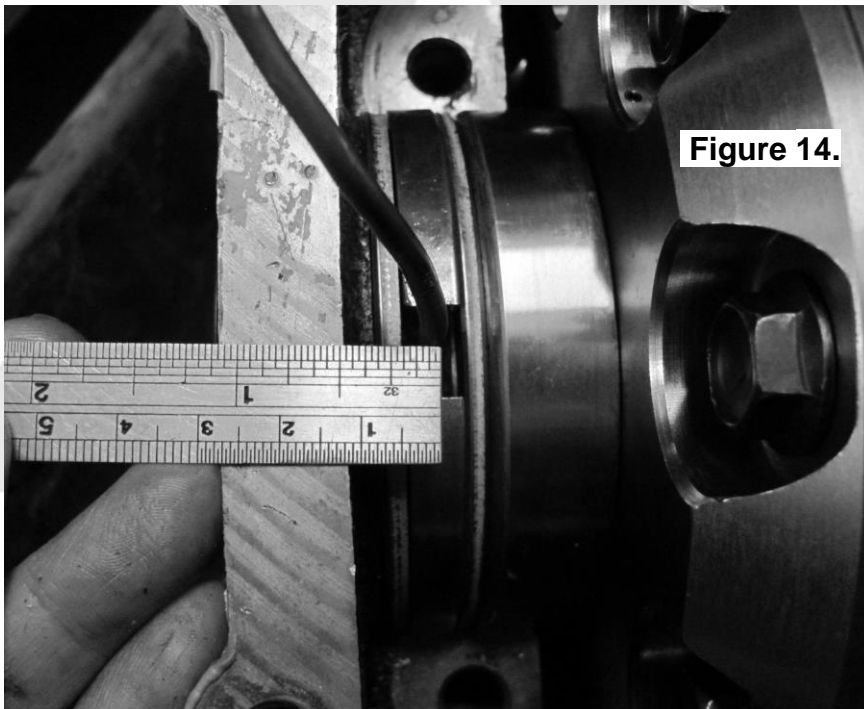

- Record your findings and recheck for accuracy.
- Remove the bearing cap from the case side of the differential.
- Remove the *Air Locker* from the differential housing.
- Install the seal housing side bearing cap and hand-tighten the bearing cap bolts.

4 Installing the Air Locker

- Measure to the bearing cap from exactly the same position on the differential housing that you took the previous measurements from. (Fig.15.)
- Mark the tube position where the clearance is to be made for the seal housing tube with a center punch.

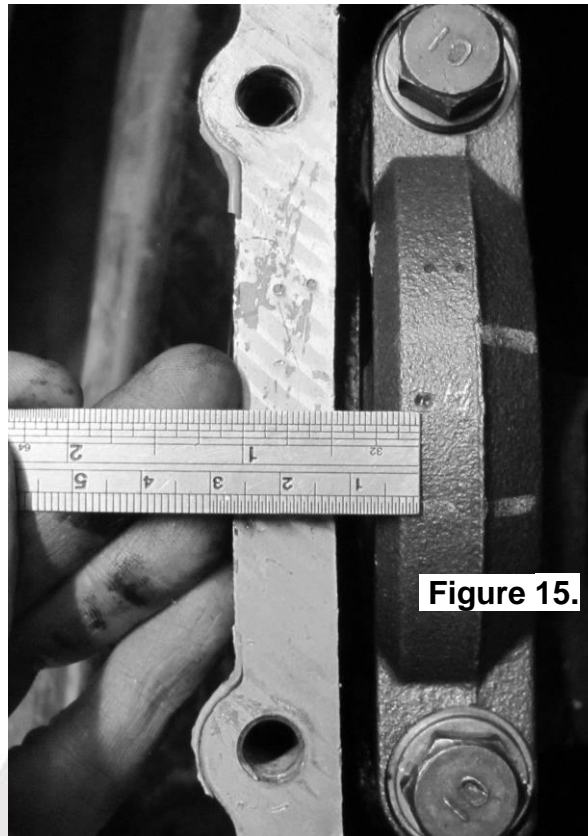

- Remove the bearing cap from the differential housing.
- Measure the distance from the center punch mark made on the bearing cap to the closest edge of the bearing cap.
- If the center punch mark is greater than 5mm [3/16"] from the closest edge of the bearing cap, it is recommended that a hole be drilled through the bearing cap (Section 4.6.2). If less than 5mm [3/16"] from the edge it is recommended that a notch is filed into the side of the bearing cap to avoid break-through while drilling (Section 4.6.3).

4 Installing the Air Locker

4.6.2 Drilling the Bearing Cap

- Hold the bearing cap steady for drilling in a soft jawed vise clamp.

NOTE : Do not apply too much clamping pressure with the vise. The bearing cap may be damaged.

- Using a pedestal drill, drill a 6.35 [1/4"] hole through the bearing cap where the seal housing tube hole has been marked. (Fig.16.)

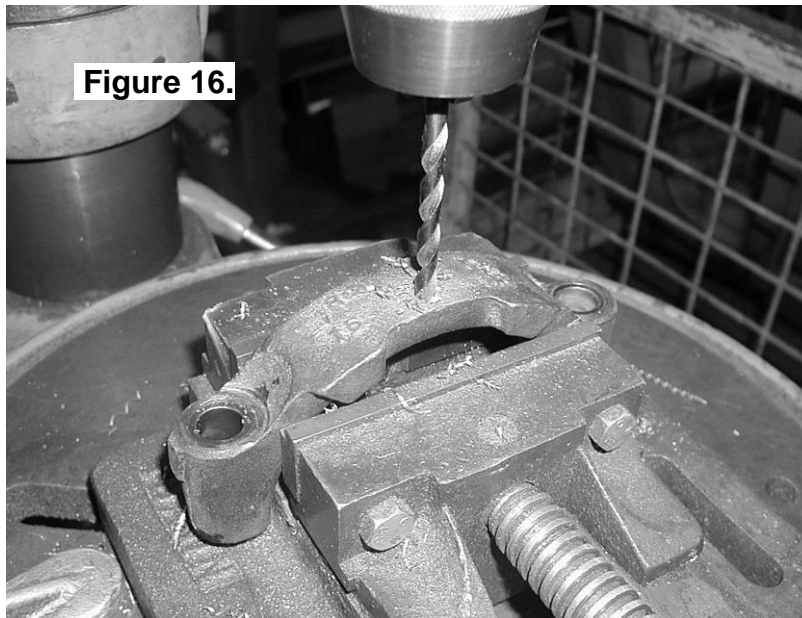

Figure 16.

- The drilled hole must be chamfered remove any sharp edges that may chip-off and fall into the housing. (Fig.17.)

4 Installing the Air Locker



4.6.3 Notching the Bearing Cap

- Use a soft jawed vise clamp to hold the bearing cap steady.
- Using a 6.35mm [$\frac{1}{4}$ "] rat-tailed file. File out a notch in the bearing cap from the closest edge until an adequate notch has been cut around the position of the punch mark. (Fig.18.).

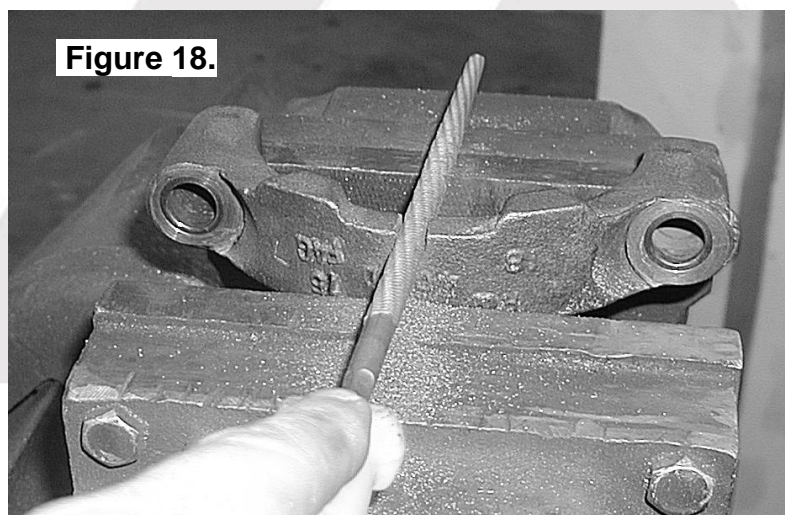

- File a chamfer around the inside edge of the notch to remove any sharp edges from the notch that may chip-off and fall into the housing.

4 Installing the Air Locker

4.7 Air Locker Final Assembly

- Remove the seal housing, shim pack, and master shim, and clean all parts of the differential assembly again. It is very important to make sure the seal housing internal walls are free from any contaminants (e.g.: water, dirt, metal fillings, etc.)
- Lubricate the O-rings on the seal housing with oil.
- Place the bearing cups onto their respective bearing cones.
- Carefully install the seal housing by sliding it all the way onto the bearing journal with a gentle twisting motion until it sits flat against the bearing cup.
- Spread the differential housing again (Refer to section 2.6)
- Assemble the respective shim pack(s) and master shim(s) to the Air Locker, making sure they are on the correct sides.
- Fit the assembly into the differential housing.

NOTE : If the carrier is too difficult to install with the added shim pack then the spreader tension may need to be increased. However, do not spread the housing more than 0.50mm [0.020"].
Alternatively, pick the thickest master shim from the ring gear side, leave it out from the assembly, and drive it in last with a shim driver

- Point the seal housing tube straight out of the housing, hold the shims and tapered roller bearing cups in place, and insert and hold the *Air Locker* into the differential housing.
- Install the bearing cap on the ring gear side.
- Check to see if the bearing cap on the seal housing side fits over the tube without fouling.

NOTE : Do not forget to check the bearing caps are turned the correct way around.

- Install all bearing cap bolts and torque to manufacturer's specs.

4.8 Final Backlash Checking

- Relieve all tension on the housing spreader.
- Tighten all bearing cap bolts with a torque wrench to the torque specified in your vehicle manufacturer's service manual.

4 Installing the Air Locker

- Set a depth indicator on one of the ring gear teeth as in Figure 19.
- While supporting the pinion gear by holding the drive shaft, rotate the differential in both directions while observing the maximum variation in depth from the indicator (i.e., the highest value minus the lowest value). This value is referred to as the ring and pinion backlash.
- Rotate the differential center 90° and measure again for accuracy.

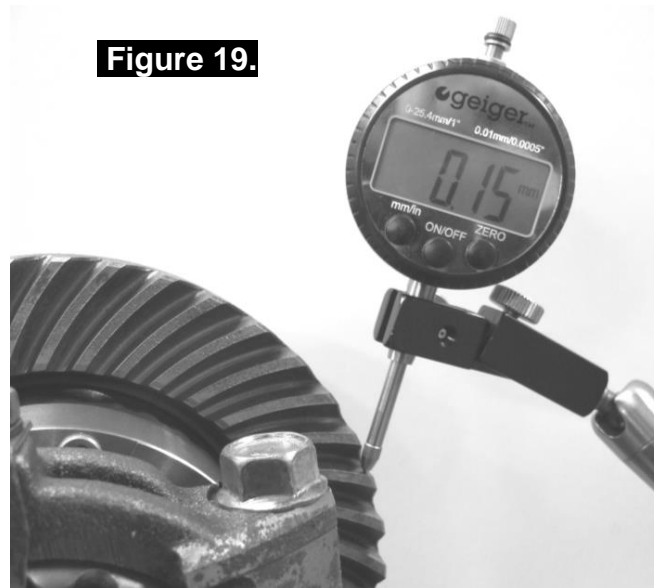

- Refer to your vehicle service manual for the specified maximum and minimum amounts of backlash. If the backlash is not within the specifications then the differential will have to be removed and re-shimmed.

4.8.1 Re-Shimming the Backlash

NOTE : This step is only necessary when adjusting for incorrect backlash.

- Reapply the spreader to the differential housing.
- Remove the bearing caps.
- Remove the differential.
- To increase the amount of backlash, increase the shim thickness 'D' (Fig.5.) and decrease the shim thickness 'E' (Fig.12.) by the same amount. Reverse this step to decrease the backlash.
- Remount the differential as before.
- Release spreader tension.
- Check backlash again as before.

4 Installing the Air Locker

4.9 Profiling the Seal Housing Tube

- Without using sharp, jagged tools such as pliers (usually your hands are the best tool for this job), bend the seal housing tube so that it closely follows the profile of the differential housing and protrudes through the bulkhead port in the differential housing. (Fig.20.)

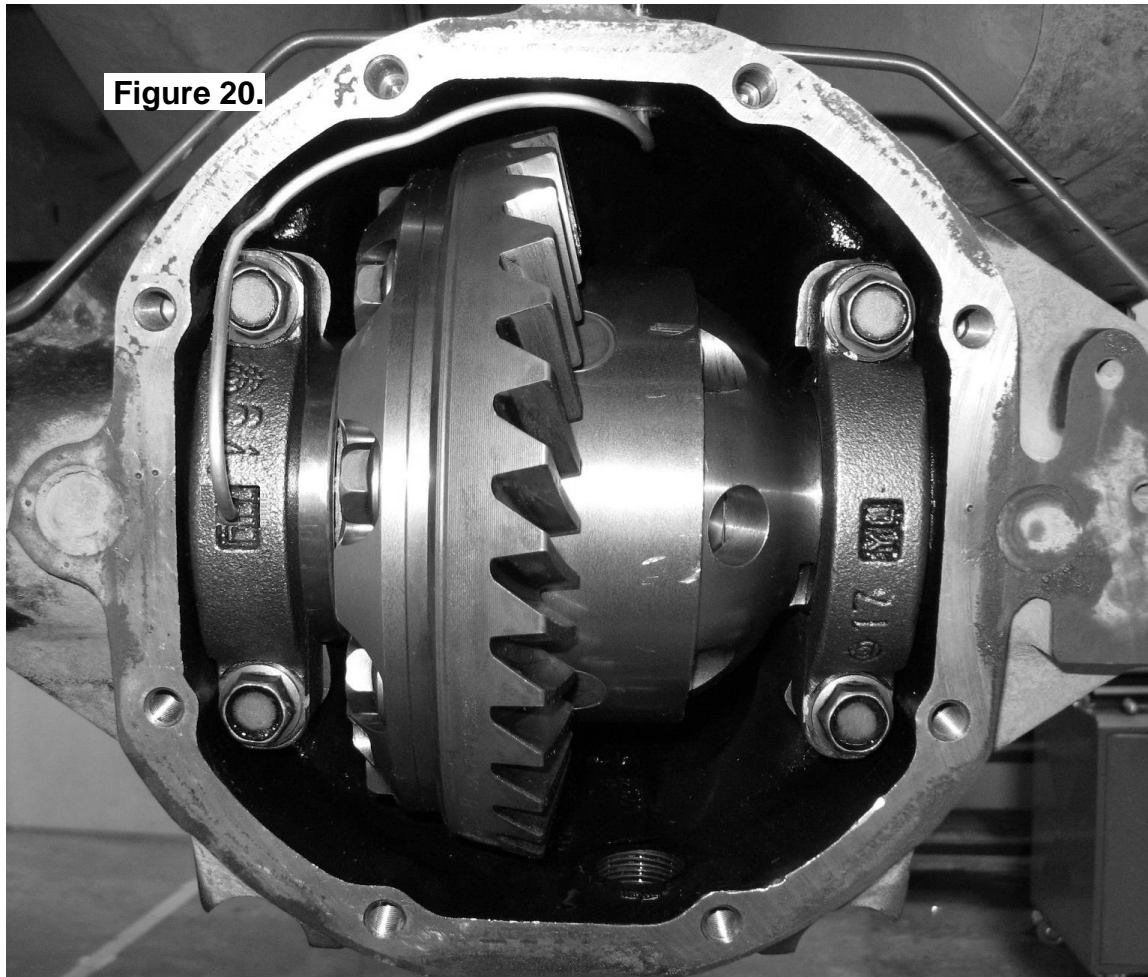

- Check that the contour of the tube will not interfere with the ring gear, differential, or the cover plate.

4 Installing the Air Locker

4.10 Setting Up the Bulkhead Fitting

- Apply thread sealant to the outside threads of the bulkhead body.
- Screw the bulkhead body into the tapped hole, and lightly tighten using a 14mm [9/16"] spanner.
- Wipe the area clean of any excess thread sealant (inside and outside of the housing).
- Insert the free end of the seal housing tube into the bulkhead fitting until it protrudes approximately 8mm [5/16"] through the other side.
- From the outside of the housing, assemble one of the small O-rings over the top of the short length of seal housing tube protruding through the bulkhead fitting.
- Install the brass spacer.
- Install the second small O-ring after the spacer.
- While holding the seal housing tube into the bulkhead fitting, insert the chamfered end of the center compression nut over the extended tube as shown in the assembly diagram (Fig. 21.), and screw it into the bulkhead body, and tighten using Pozidriv #3 screwdriver.

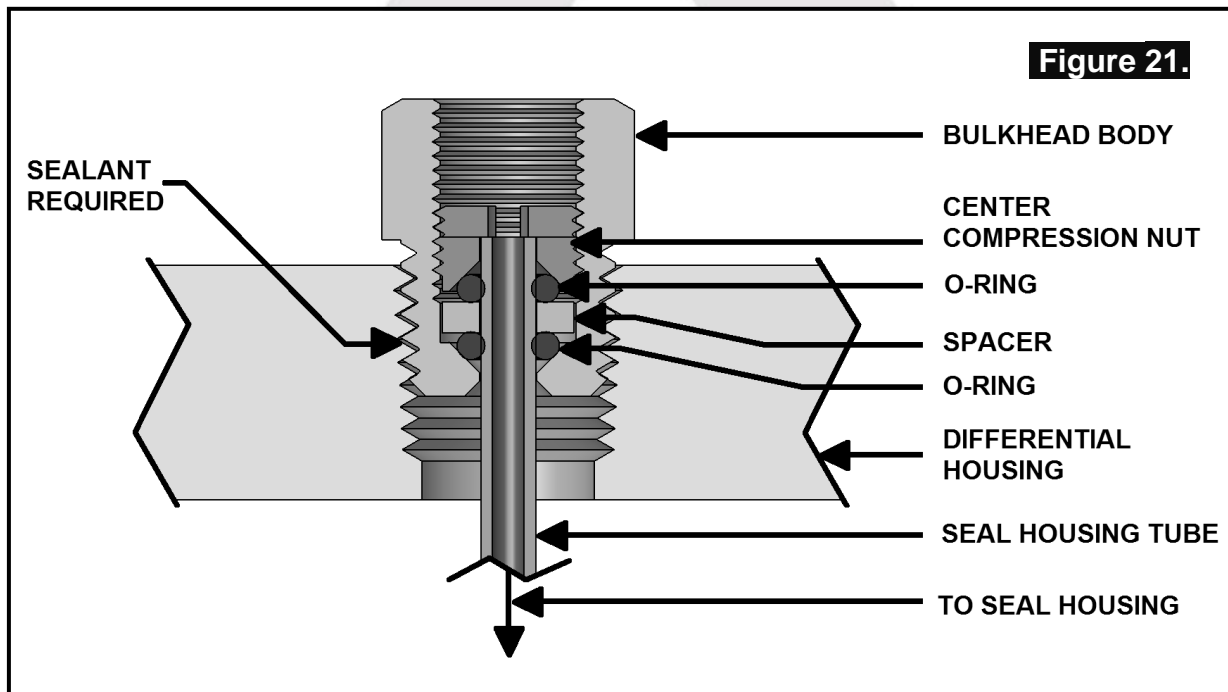

4 Installing the Air Locker

NOTE : Make sure the seal housing tube is all of the way into the center compression nut while you are tightening it.

NOTE : Firmly tighten the center compression nut so that a good seal is formed around the tube.

4.11 Bench Testing the Air Locker

- To test the *Air Locker*, when 620kPa [90 PSI] shop air is applied to the seal housing tube, the *Air Locker* should engage.
- Check all fittings and the seal housing for air leaks.
- Rotate the differential carrier by turning the pinion flange whilst applying air pressure.

NOTE : An accurate way to test for air leaks is to fit a shut-off valve to an air pressure gauge. (ARB part # 0770005 shown in Fig.21.). Once 620 KPA [90 PSI] is reached close the valve, disconnect the air hose, and watch to see if there is any drop in pressure. If so, this will indicate an air leak.

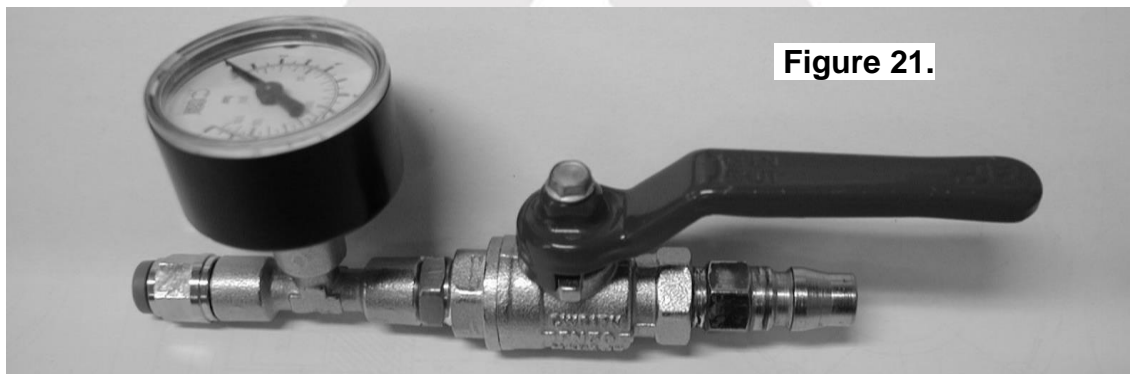

Figure 21.

- If a leak is found to be present, spray a soap and water mixture onto the bulkhead air fitting. Bubbles should appear at any leak points.

NOTE : Do not spray this soapy mixture inside the differential.

- Check that leaky fittings have been adequately tightened.
- Disassemble, clean threads, and reapply thread sealant if leaking persists.
- If a leak is found at the seal housing, carefully remove and refit. Be very careful with the O-rings and check they have not been damaged during installation.

4 Installing the Air Locker

4.12 Reinstalling the Axles

Reinstall the axles and brake assembly according to the guidelines set forth in your vehicle manufacturers service manual.

NOTE : Be careful not to damage the axle oil seals with the spline of the axle when inserting them.

NOTE : If you have semi-floating axle shafts then carefully check the axle end float to make sure you have correctly installed the thrust block.



5 Installing the Air System

5.1 Mounting the Solenoid

5.1.1 Connection to an ARB Air Compressor (Fig.22.)

- Remove one of the 1/8" BSP plugs from its port in the compressor tank.
- Apply Teflon paste to the 1/8" BSP nipple on the solenoid and insert it into the port and tighten. The solenoid should be rotated into a position which does not obstruct any other ports on the compressor tank.

NOTE : The coil and stem of the solenoid can be removed to make installation easier.

NOTE : The solenoid is marked with two #1 ports. If space is tight, a second solenoid can be "daisy-chained" off the first one by removing the plug from the redundant #1 port and screwing the nipple from the second solenoid into it (Fig. 22.).

NOTE : The solenoid exhausts compressed air through the center of the black retaining cap when the *Air Locker* is disengaged. Make sure this orifice cannot be obstructed.

- Assemble the 6mm push-in fitting into the solenoid outlet port (stamped "2") and hand tighten.

Figure 22.

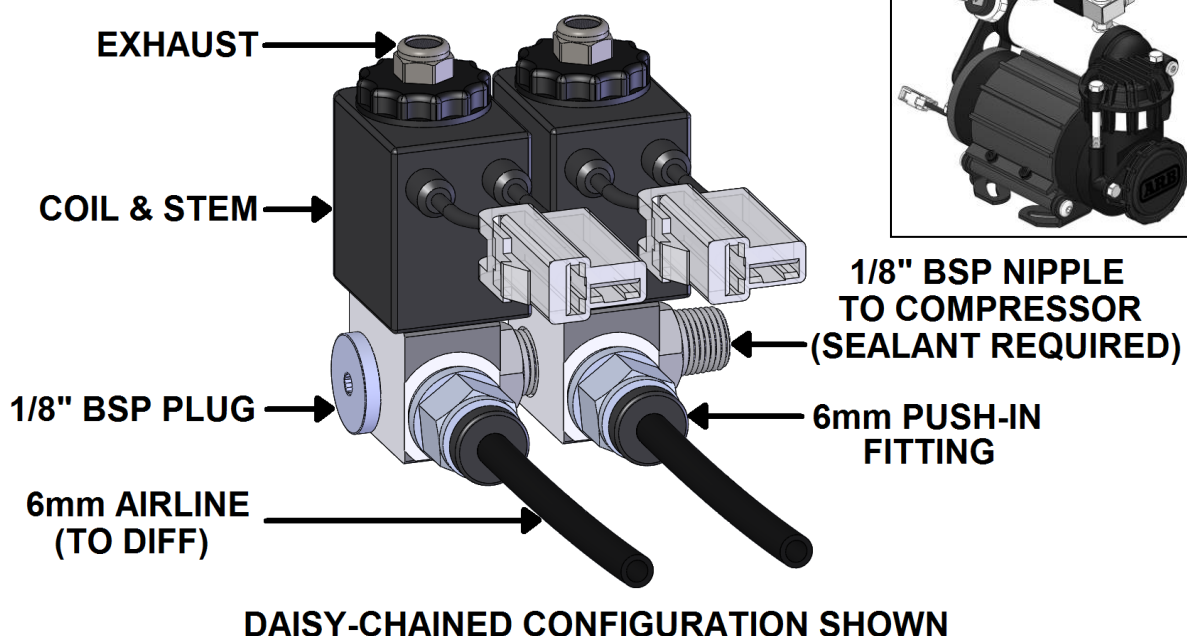

5 Installing the Air System

5.1.2 Connection to an Alternate Air Source

For ease of installation, quality of air supply, and a high level of dependability from your *Air Locker(s)*, ARB strongly recommends use of a genuine ARB Air Compressor, however, the *Air Locker* air system can be operated on any alternate air source that meets each of the following guidelines:

- Must supply a minimum of 586kPa [85PSI].
- The Air source should have a tank capacity that enables it to actuate the *Air Locker(s)* in one charge so that no hesitation is experienced when locking one or two differentials.

HINT : A good way to ensure that you have the necessary capacity is to make sure you can engage, disengage, and then re-engage your *Air Locker(s)* without the air source having to regenerate (e.g., without the compressor turning on to refill the tank).

- Must supply clean air, free of rust, dirt, water, or other foreign matter.
- Must match the 1/8" BSP porting of the *Air Locker* solenoid.
- Mount solenoid within close proximity of the air supply and secure it from the effects of vibration and shock.
- Connect the air supply to the 1/8" BSP inlet port of the solenoid (stamped "1" on the solenoid body) using thread sealant.

IMPORTANT :

ARB cannot warrant your *Air Locker(s)* against damage caused as a result of using an alternate air supply. If you have any doubts as to the suitability of your air system to use in an *Air Locker* system, consult your ARB distributor.

5 Installing the Air System

5.2 Running and Securing the Air Line

The path taken by the air line from your air source (i.e., compressor) to your *Air Locker* is unique to your vehicle and the position of your air source. Plan ahead carefully when running the air line and always follow these guidelines:

- Account for axle travel when running the line from the axle to a fixed point on the vehicle. Leave enough slack in the air line to allow for maximum suspension travel in both directions.
- Avoid leaving large lengths of air line hanging underneath the vehicle where they may get tangled on rocks, sticks, etc.

HINT : **Cable tying the air line to one of your flexible brake lines will account for axle travel and should help keep your line from getting snagged.**

- Run the air line all the way from the compressor to the differential before trimming either end of the line to length. This will save complications that may arise if the air line has to be removed.
- Make sure the line does not contact sharp edges or abrasive surfaces that may damage the air line over time.
- Do not run the air line around tight bends which may kink the air line and restrict or block the air flow.
- Keep the air line well away from your vehicle's exhaust components. Air lines will melt if subjected to extreme heat.
- Do not run more air line than necessary. Excess line volume created when coiling the left over hose, using unusually large diameter hose, etc., will increase drain on the compressor tank resulting in the compressor running more often than needed.
- Support the air line by tying it back with cable ties wherever possible.
- At the solenoid end of the air line, trim the line to length with a sharp knife.
- To attach the air line to the push-in fitting of the solenoid; insert the line firmly into the fitting, pull outward on the flange of the fitting while holding the line as far into the fitting as possible, and then gently pull outward on the air line to clamp the line in place.

5 Installing the Air System

NOTE : To remove the air line from the push-in fitting; push the air line into the fitting as far as possible, then press the flange inward, then pull the air line free of the fitting.

5.3 Connection to the Bulkhead Fitting

- Trim the air line to length using a sharp knife.
- Assemble an aluminium washer onto the banjo bolt and insert through the banjo fitting. Assemble second aluminium washer and tighten into bulkhead fitting using a 14mm [9/16"] spanner. (Fig.23.)
- Apply thread sealant to the tapered thread of the compression fitting body and screw into the banjo fitting. Tighten using a 12mm spanner.
- Insert the outer compression nut and ferrule over the air line. Ferrule should be orientated as per Fig.23.

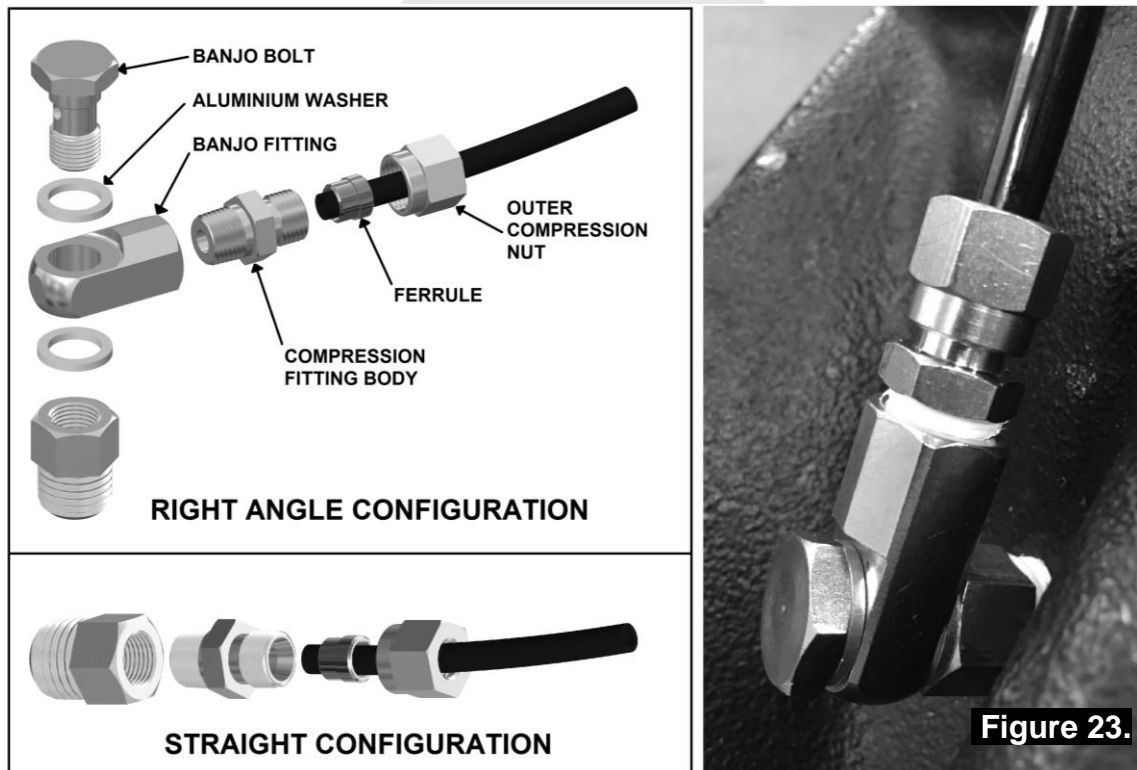

5 Installing the Air System

- Push the airline into the compression fitting body and screw the outer nut down onto it. Using a 12mm spanner, tighten the outer nut onto the compression fitting body.

NOTE : Some force is required to crush the ferrule, however the outer compression nut will tighten against a stop. Over tightening will not create a better seal.

- Secure any loose sections of tube with a cable tie.

NOTE : When right angle routing of the tube is not required, screw the compression fitting body straight into the bulkhead fitting body (Fig. Error! Reference source not found.).



6 Mounting & Connecting the Electrical System

6.1 Mounting the Actuator Switch(es)

Air Locker actuator switch(es) can be easily panel mounted inside the vehicle in a 21mm x 36.5mm [0.83" x 1.44"] rectangular cutout.

NOTE : Only attach the cover plate to the face of the switch once the switch has been mounted and wired correctly as the cover plates are designed to be difficult to remove.

For reasons of safety and for ease of operation, the *Air Locker* actuator switch(es) should be mounted in a location picked to best suit the operator. Make sure you have taken the following points into consideration:

- Switch(es) MUST be mounted and should never be allowed to simply dangle from the wiring loom during vehicle use.
- Switch(es) should be within easy reach of the driver. Ideally, any *Air Locker* switch should be able to be operated without physical effort or distraction to the driver.
- Switch(es) should be mounted within the line of sight of the driver so that switch position ('ON' or 'OFF') can be visually determined by the rocker position and the illumination state.
- The position of the switch(es) should best eliminate any possibility of accidental operation by the driver or one of the passengers.
- Switch cutout position(s) must be located in an area with a minimum of 50mm [2"] of clearance behind the face of the cutout.
- Switch(es) should not be mounted where they will be exposed to water (e.g., in the lower section of an inner door panel).
- ARB recommends that you apply the *Air Locker* Warning Sticker (ARB part # 210101) within close visual proximity of the switch location.

NOTE : If no adequate position can be found on existing dashboard panels, a surface mounted bracket (Fig. 24.) may be purchased from your *ARB Air Locker* distributor to suit 1, 2, or 3 switches.

6 Mounting & Connecting the Electrical System



6.2 Wiring the Actuator System

6.2.1 Connection to an ARB Air Compressor

When wiring the *Air Locker* actuator switch(es) and solenoid(s) to an ARB Air Compressor, all connections can easily be set up directly from the supplied wiring loom. (Fig. 25.)

NOTE : 180409 model loom shown for reference only. Refer to your ARB Air Compressor Installation Guide for details on configuring your installation.

6 Mounting & Connecting the Electrical System

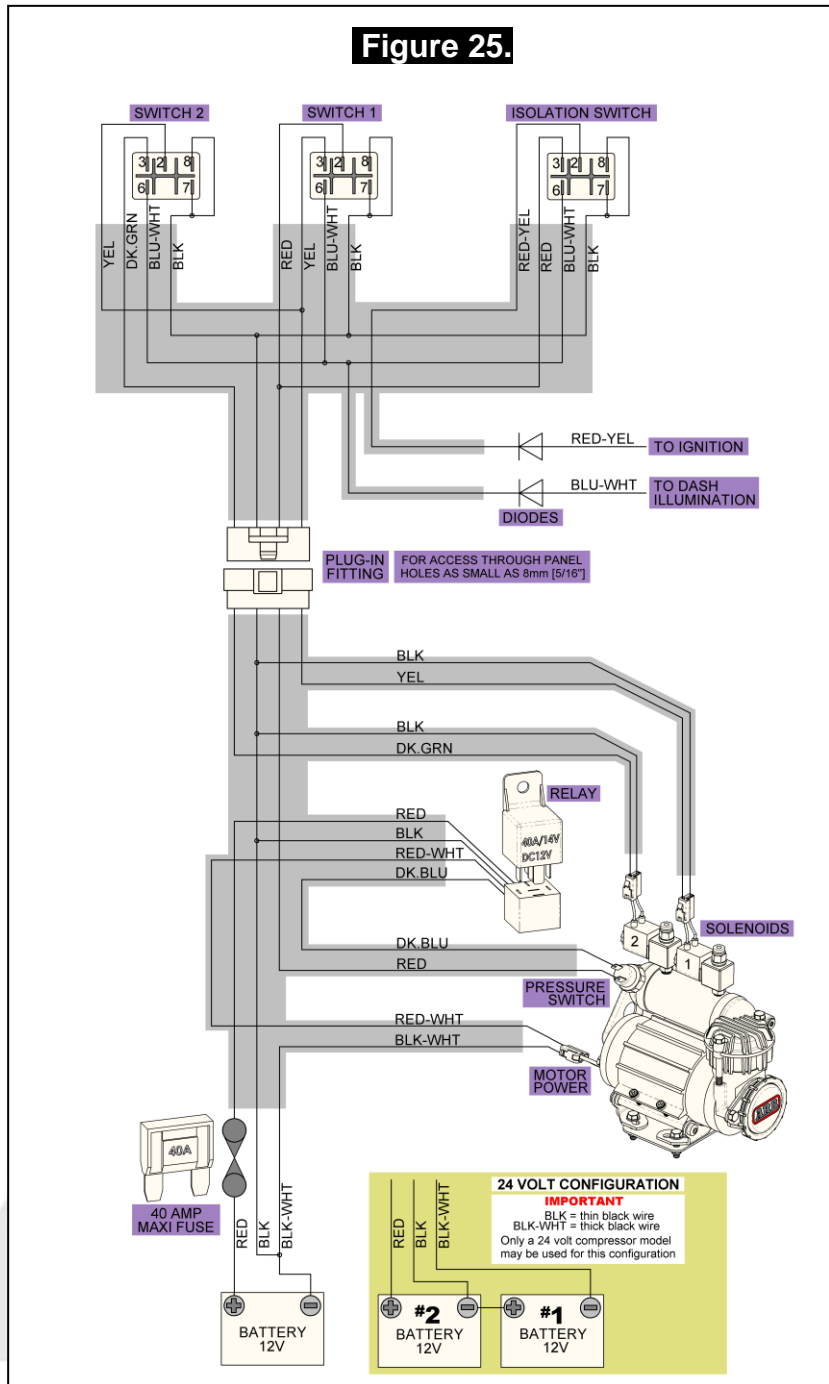

6 Mounting & Connecting the Electrical System

6.2.2 Connection to an Alternate Air Source

When connecting the actuation switch to an alternate air source, the switch(es) should be wired according to figures 27. and 28., depending on whether one or two *Air Lockers* will be installed in the vehicle.

6.2.2.1 Single Air Locker System

- If only one *Air Locker* is to be installed in the system, the switch and solenoid should be wired according to figure 27. regardless of whether the *Air Locker* has been installed in the front or rear axle of the vehicle.
- Attach the appropriate switch cover (i.e., 'FRONT' or 'REAR') to the switch.

NOTE : Refer to Figure 26. for the correct switch terminal identification and switch orientation.

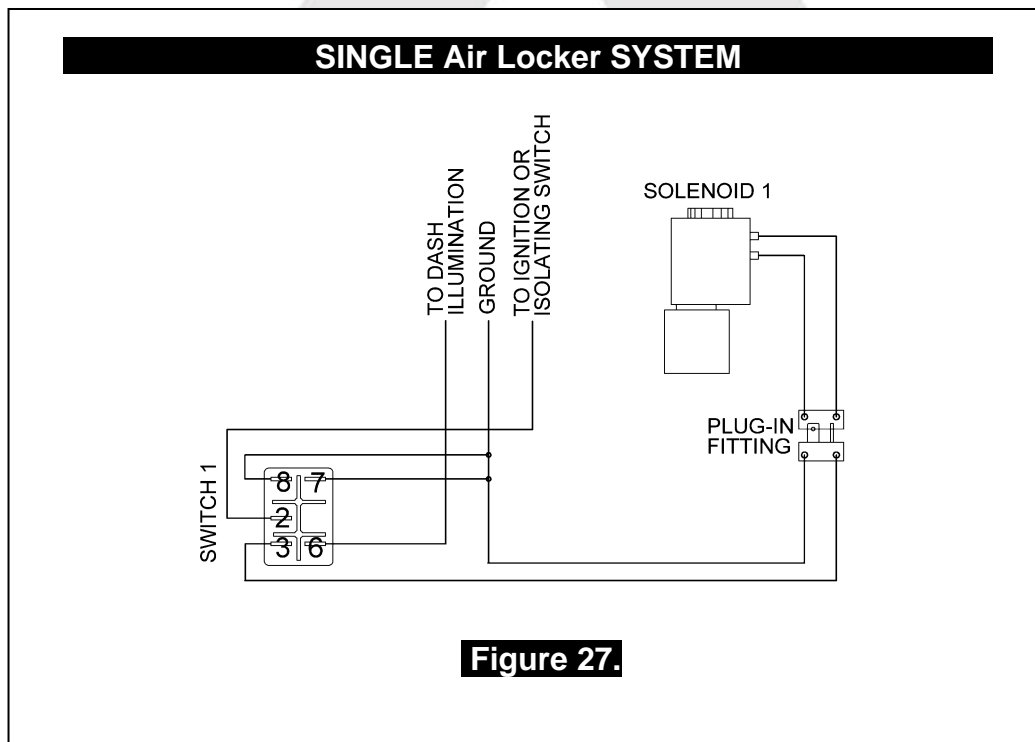

6 Mounting & Connecting the Electrical System

6.2.2.2 Dual Air Locker System

- If two *Air Lockers* are to be installed in the system, ARB recommends that the switches and solenoids be wired according to figure 28. For safety reasons, this configuration allows SOLENOID 2 to be actuated only if SOLENOID 1 is already on.
- Attach the “REAR AIR LOCKER” switch cover to SWITCH 1, and the “FRONT AIR LOCKER” switch cover to SWITCH 2.

NOTE : Refer to Figure 26. for the correct switch terminal identification and switch orientation.

- Configure SOLENOID 1 as the air line leading to the rear axle *Air Locker*, and SOLENOID 2 as the air line leading to the front axle *Air Locker*.

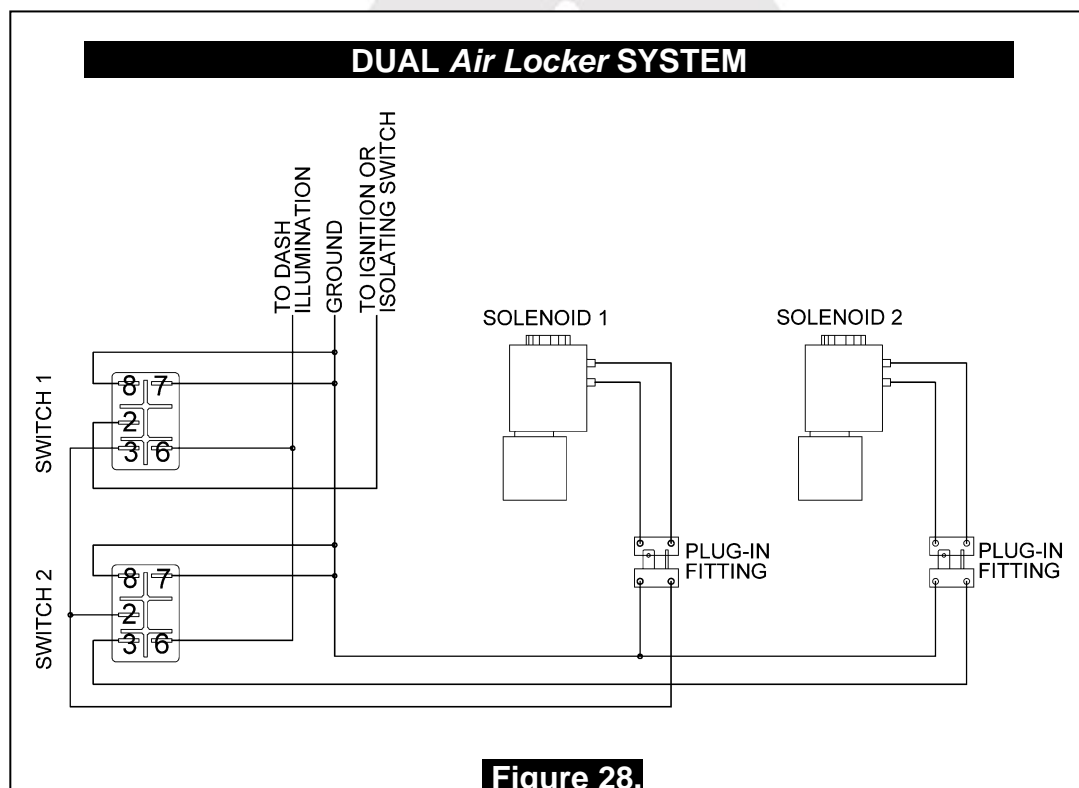

7.1 Leak Testing

- With the vehicle parked and the engine off, turn the compressor on and wait until the air system is fully charged.

7 Testing & Final Assembly

NOTE : With the *Air Locker(s)* disengaged, the air source (i.e., compressor) should not have to recharge over time. Intermittent recharging without *Air Locker* use usually indicates a leak at the solenoid fittings or at the compressor tank O-ring seal.

- Actuate the *Air Locker(s)*.
- The compressor should not come on again for a period of at least 15min. Air system recharging within that time period would indicate that a leak is present in the system.

NOTE : If an alternate air source (e.g., an air cylinder or a belt driven air pump) is used instead of a compressor, the air system will have to be leak tested with a pressure gauge and a shut-off valve in series before the solenoid input.

- If a leak is found to be present, spray a soap and water mixture onto all air fittings in the system while the compressor is fully charged. Bubbles should appear at any leak points.
- Check that leaky fittings have been adequately tightened.
- Disassemble, clean threads, and reapply thread sealant if leaking persists.

7.2 Testing the Air Locker Actuation

To test that your air system, electrical system, and your *Air Locker* differential is functioning correctly:

- Support the vehicle such that the wheels are free to rotate (e.g., on axle stands, a chassis hoist, etc.)
- Leave the parking brake off, the transmission in neutral, and the *Air Locker* switch 'OFF'.
- Turn the ignition to the 'ON' position (leaving the motor off). The large illuminating symbol on the *Air Locker* switch cover should be 'OFF'.
- Turn the compressor (or alternate air source) on to charge the air supply up to its maximum pressure.
- Rotate one wheel by hand.

7 Testing & Final Assembly

- The wheel should rotate freely and the opposite wheel should be turning in the opposite direction without any resistance or mechanical noise from within the differential.
- Turn the *Air Locker* switch to the 'ON' position. The illuminated symbol on the switch cover should light up.
- Rotate the same wheel again.
- Both wheels should rotate together.
- Turn the switch off again.
- Rotate the same wheel.
- The wheels should again rotate in opposite directions.

7.3 Re-Sealing & Filling the Differential

NOTE : Consult the *ARB Air Locker Operating & Service Manual* for recommendations on differential lubricant specifications.

- Replace the differential cover using gasket sealant or a new standard differential cover gasket for your make of vehicle.
- Refill the differential until level with the filler hole.
- Rotate the differential center 2 full turns.
- Check the oil level and add oil if necessary.
- Replace filler plug (apply thread sealant to filler plug before inserting if it is a threaded type plug).
- Wipe differential housing clean of any oil or grease which may collect dirt or other abrasive particles.

7 Testing & Final Assembly

7.4 Post-Installation Check List

Now that the *Air Locker* installation has been completed, ARB recommends that you take the time to complete the following check list just to insure that you haven't missed any of the vital steps.

- The air system has been leak tested.
- Thread locking compound was used on the ring gear bolts.
- All torque settings comply with the vehicle manufacturer's specs and were set with an accurate torque wrench.
- Differential fluid complies with ARB recommendations and has been filled to the correct level.
- All air lines and wiring have been securely cable tied to resist snagging.
- Switch(es) have been securely mounted within operator reach, yet well away from danger of accidental engagement.
- Switch(es) function properly and illuminate to indicate that *Air Locker(s)* have been engaged.
- All operators who are to use the *Air Locker* have read, and fully understand the *ARB Air Locker Operating & Service Manual*.
- The *Air Locker* Warning Sticker has been located within close proximity of the actuator switch(es).

INSTALLATION PERFORMED BY: _____

DATE OF INSTALLATION: _____

ODOMETER READING: _____

ARB AIR LOCKER SERIAL No.: _____





8 Parts List

RD201

Nissan C200,31 SPL

8.1 Exploded Assembly Diagram

(See itemized parts list overleaf)

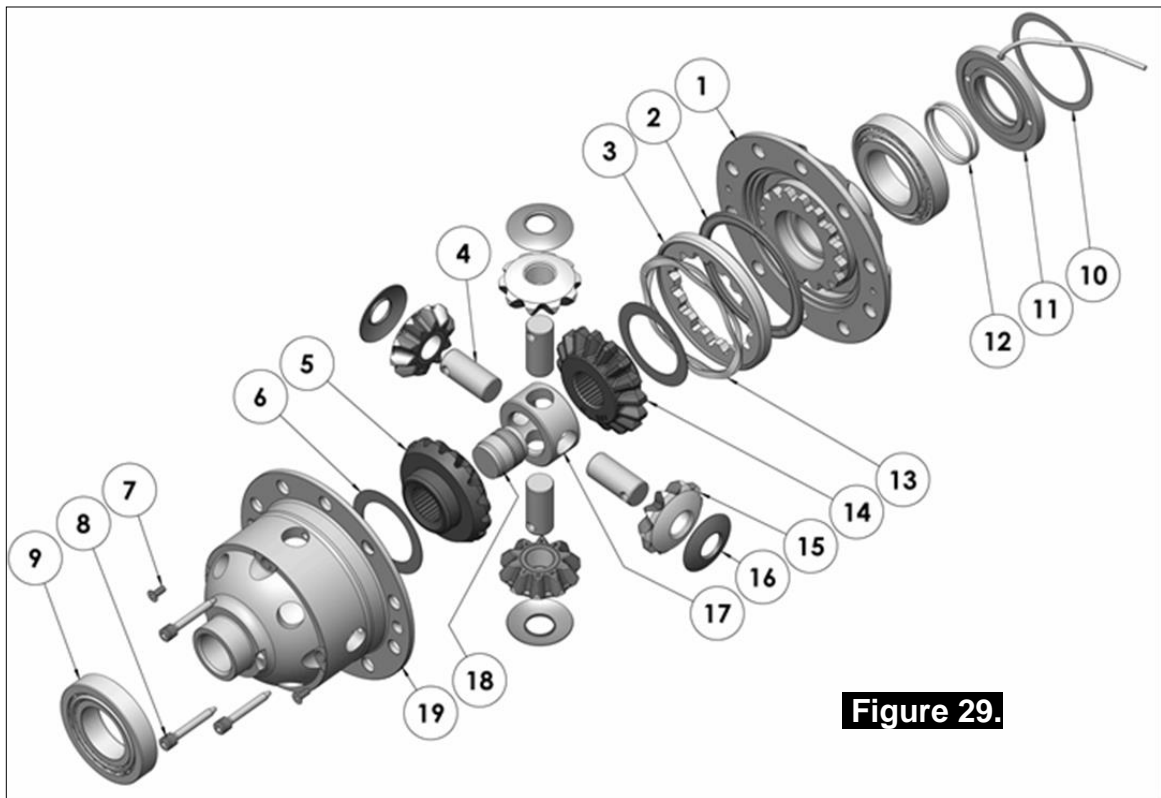

Figure 29.

8.2 Specifications

Axle Spline	31 tooth, Ø32.0mm [1.26"]
Ratio Supported	All
Ring Gear ID	128.0mm [5.04"]
Ring Gear Bolts	10 bolts on Ø150mm [5.91"]
Ring Gear Bolt Size	12mm
Ring Gear Torque	120Nm [89 ft-lb]
Backlash	0.13-0.18mm [0.005-0.007"]
Bearing Cap Torque	93Nm [69 ft-lb]

8 Parts List

8.3 Itemized Parts List

(See exploded diagram figure 29.)

ITEM #	QTY	DESCRIPTION	PART #	NOTES
1	1	FLANGE CAP KIT	027334SP	
2	1	BONDED SEAL	160702SP	
3	1	CLUTCH GEAR & WAVESPRING KIT	050906SP	
4	4	SHORT CROSS SHAFT	060403SP	
5	1	SIDE GEAR	SEE NOTE	2
6	2	SIDE GEAR THRUST WASHER	SEE NOTE	3
7	1	COUNTERSUNK SCREW (PK OF 2)	200213SP	
8	1	RETAINING PIN SET (PK OF 4)	120601SP	
9	*	TAPERED ROLLER BEARING	NOT SUPPLIED	
10	1	SHIM KIT	SHK009	
11	1	SEAL HOUSING KIT	080803SP	
12	1	SEAL HOUSING O-RINGS (PK OF 2)	160205-2	1
13	1	WAVESPRING	150706SP	
14	1	SPLINED SIDE GEAR	SEE NOTE	2
15	4	PINION GEAR	SEE NOTE	2
16	4	PINION THRUST WASHER	SEE NOTE	3
17	1	SPIDER BLOCK	070201SP	
18	1	THRUST BLOCK	110501SP	
19	1	DIFFERENTIAL CASE	013033SP	
*	1	BULKHEAD FITTING (BANJO TYPE)	170114	4
*	1	AIR LINE (6mm DIA X 6m LONG)	170314SP	4
*	1	SOLENOID VALVE (12V)	180103	
*	1	SWITCH RR LOCKER	180224	
*	1	CABLE TIE (PK OF 25)	180305	
*	1	OPERATING & SERVICE MANUAL	210200	
*	1	INSTALLATION GUIDE	2102201	

* *Not illustrated in exploded view*

NOTES

- 1 For replacement O-rings use only BS132 Viton 75.
- 2 Available only as complete 6 gear set # 728H151
- 3 Available only as complete thrust washer kit #730H01
- 4 All diffs produced before serial #17070001 came with 5mm air connection system.
For information contact ARB.
- When used with 10mm ring gear bolts, adapter sleeves of the following size are required:
Outside: Ø12.15mm [0.478"]
Inside: Ø10.45mm [0.411"]
Length: 10mm [0.39"]
Bolt Torque: 74Nm [55 ft-lb]
- Refer to axle modification tech note (Sec. 5.4) if axle binds inside carrier.
- Refer to pinion modification tech note (Sec. 5.6)
- For 29 spline model refer to RD202 (Sec. 2.202)

Part No. 2102201
Revision 27/10/2020
Copyright © 2015 by ARB Corporation Limited

