



# FITTING INSTRUCTIONS

Part Number: **3423140 F/Kit 6173362**  
Product **COMBINATION BULL BAR**  
Description:  
Suited to **TACOMA 2012 ON**  
vehicle/s:

## WARNING

### REGARDING VEHICLES EQUIPPED WITH SRS AIRBAG:

When installed in accordance with these instructions, the front protection bar does not affect operation of the SRS airbag.

### ALSO, NOTE THE FOLLOWING:

- ◆ This product must be installed exactly as per these instructions using only the hardware supplied.
- ◆ In the event of damage to any bull bar component, contact your nearest authorised ARB stockist. Repairs or modifications to the impact absorption system must not be attempted.
- ◆ Do not use this product for any vehicle make or model, other than those specified by ARB.
- ◆ Do not remove labels from this bull bar.
- ◆ This product or its fixing must not be modified in any way.
- ◆ The installation of this product may require the use of specialized tools and/or techniques
- ◆ It is recommended that this product is only installed by trained personnel
- ◆ These instructions are correct as at the publication date. ARB Corporation Ltd. cannot be held responsible for the impact of any changes subsequently made by the vehicle manufacturer
- ◆ During installation, it is the duty of the installer to check correct operation/clearances of all components
- ◆ Work safely at all times
- ◆ Unless otherwise instructed, tighten fasteners to specified torque

## ARB 4x4 ACCESSORIES

### Corporate Head Office

42-44 Garden St  
Kilsyth, Victoria  
AUSTRALIA 3137

Tel: +61 (3) 9761 6622  
Fax: +61 (3) 9761 6807

Australian enquiries  
North & South American enquiries  
Other international enquiries

sales@arb.com.au  
sales@arbusa.com  
exports@arb.com.au

**www.arb.com.au**

# GENERAL CARE AND MAINTENANCE

By choosing an ARB Bar, you have bought a product that is one of the most sought after 4WD products in the world. Your bar is a properly engineered, reliable, quality accessory that represents excellent value. To keep your bar in original condition it is important to care and maintain it following these recommendations:



- Prior to exposure to the weather your bar should be treated to a Canuba based polish on all exposed surfaces. It is recommended that this is performed on a six monthly basis or following exposure to salt, mud, sand or other contaminants.
- As part of any Pre Trip Preparation, or on an annual basis, it is recommended that a thorough visual inspection of the bar is carried out, making sure that all bolts and other components are torqued to the correct specification. Also check that all wiring sheaths, connectors, and fittings are free of damage. Replace any components as necessary. This service can be performed by your local authorized ARB Stockist.

## FITTING REQUIREMENTS

### REQUIRED TOOLS FOR FITMENT OF PRODUCT:

<b>Basic Tool Kit</b>	<b>External Circlip pliers</b>
<b>½" and ¼" socket set</b>	<b>Power Drill 13mm capacity</b>
<b>Dia 10 and 13mm drill bits</b>	<b>Non permanent marker</b>
<b>Tape measure - metric</b>	<b>Masking tape</b>
<b>Jig saw with blade to suit plastic cutting</b>	

### HAVE AVAILABLE THESE SAFETY ITEMS WHEN FITTING PRODUCT:

<b>Protective eyewear</b>		<b>Hearing protection</b>	
---------------------------	---	---------------------------	---

**NOTE: 'WARNING' notes in the fitting procedure relate to OHS situations, where to avoid a potentially hazardous situation it is suggested that protective safety gear be worn or a safe work procedure be employed. If these notes and warnings are not heeded, injury may result.**

### FASTENER TORQUE SETTINGS:

SIZE	Torque Nm	Torque lbft
M6	9Nm	7lbft
M8	22Nm	16lbft
M10	44Nm	32lbft
M12	77Nm	57lbft

### OPTIONAL LIGHT SETS TO SUIT THIS PRODUCT:

- ◆ **ARB 6821201 Fog Light Kit Suit 3163015**

## PARTS LISTING

APPLICATION.	PART NO.	QTY	DESCRIPTION
<b>Chassis Mount Assembly</b>	3759006	1	Bracket Mount Assembly
	3756794L	1	Bracket Tension LHS
	3756794R	1	Bracket Tension RHS
	6151095	4	Bolt M12 x 1.25 x 35mm
	6151135	4	Nut M12 x 1.25
	4581049	6	Washer Flat ½"
	4581050	6	Washer Spring ½"
	4581007	6	Washer Flat M12 x 4mm HD (Large )
	6151104	2	Bolt ½"x 4" UNC
	6151139	2	Nut ½' UNC Nut M10 x 1.25
	6151133	2	Nut M10 x 1.25
	4581040	10	Washer Flat M10
	4581048	6	Washer Spring M10
	6151232	4	Bolt M10 x 1.5 x 30mm
	6151026	4	Nut M10 x 1.5
3194380	2	Plate Spacer	
<b>Bull Bar To Chassis Mount Assembly</b>	6151321	10	Nut Flange M10 x 1.5
	6151357	10	Bolt SEMS M10 x 1.5 x 30mm
<b>Stone Tray to Bull Bar</b>	6522885	1	Stone Tray
	6151300	8	Nut Cage 6mm
	6151180	8	Bolt M6 x 20mm
	4581072	8	Washer Flat M6
	4581036	8	Washer Spring M6
<b>Buffers To Bull Bar</b>	3162470R	1	Buffer Standard RHS
	3162470L	1	Buffer Standard LHS
	6151128	12	Nut Flange M6
<b>Indicators To Bull Bar</b>	3163015	1	Combination Light Surround Kit
	6821152	2	Turn signal / clearance light loom
	6821151L	1	Turn Signal / Clearance Light
	6821151R	1	Turn Signal / Clearance Light
	6821192	2	Bulb 10W 12V BA15S
180701	6	Scotch Loks	
<b>Licence Plate To Bull Bar</b>	6151128	4	Nut Flange M6
	6151046	4	Washer Flat M6
	6151180	4	Bolt M6 x 20mm
	3751313	1	Bracket Number Plate
<b>Miscellaneous</b>	EG50	1	Rubber Grommet 3/8" ID
	180302	10	Cable Ties
	BLB850	3	Cable Black 850mm
	6151074	4	3/8" x 13/4" UNC Bolts
<b>Bracket Control Box to Bull Bar</b>	3751564	1	Bracket control box mount
	6151021	2	Bolt M8 x 20mm
	4581044	2	Washer Flat M8
	6151132	2	Nut Flange M8

## FITTING PROCEDURE



1. Remove licence plate from bumper
2. Remove grille from vehicle, you will need to remove top bolts, then release lower grille tabs by pushing up, see below

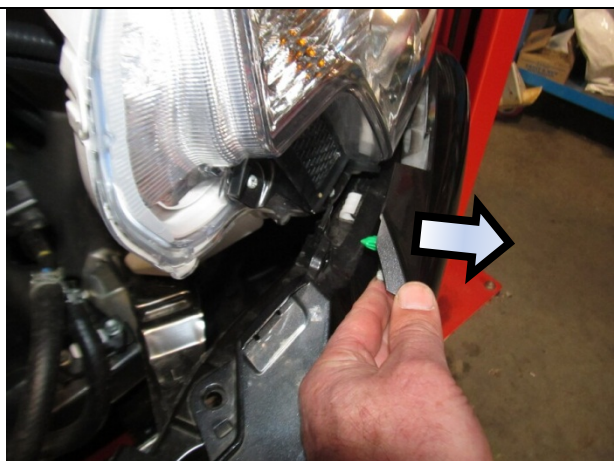

3. Remove trims from under headlamps. Pull inboard end outwards, then pull the trim away from bumper clip in direction of arrow



4. Remove bumper from vehicle by undoing lower bolts, clips to cross member, wheel arch bolts. Pull bumper ends out and away from vehicle to release them from clips. Place on work stand front face up.



5. Remove flare sections from bumper by using a screw driver or similar to depress clip tabs then set aside, these items will not be reused



## FITTING PROCEDURE



6. Mark out bumper cutting line position on LH and RH sides above fog lamp areas by measuring down from rear top edge of bumper as shown at 85mm and marking either with non permanent marker or piece of masking tape



7. Mark out bumper cutting line position on LH and RH sides above air intake area, entre of bumper by measuring down from *in front* of the rear top edge of bumper as shown at 100mm and marking either with non permanent marker or piece of masking tape

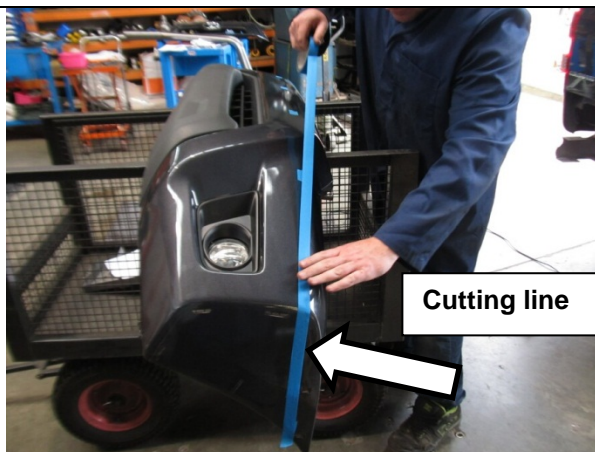

8. Apply a continuous piece of masking tape with the top edge coincident with the 100mm and 85mm cutting line positions and run end of tape to wheel arch area of bumper as shown on both sides

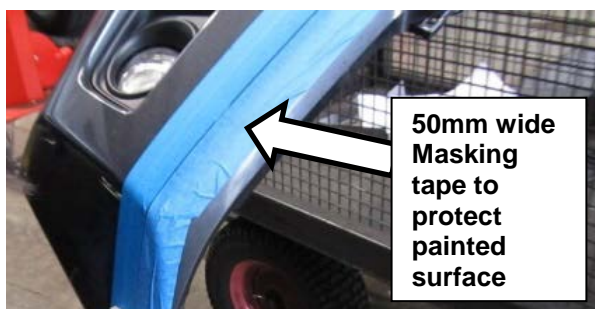

9. Apply a 50mm wide section of masking tape to protect the surface of the top of the bumper which is retained. Leave a small gap to the cutting line edge of the cutting line tape

## FITTING PROCEDURE

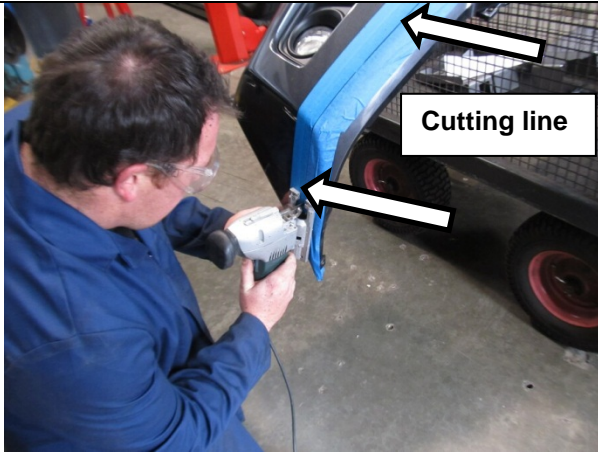

- Using a jig saw or similar, carefully cut bumper along marked line as shown



**Cutting operations may result in flying debris, please wear protective goggles**

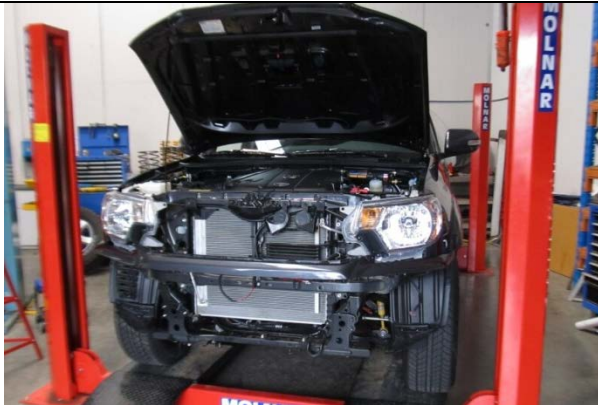

- Remove masking tape and deburr edge with file or sandpaper
- Refit cut bumper to vehicle



- Refit bumper trims and grille



- Remove crash beam, retain nuts, set crash beam aside this will not be reused.



## FITTING PROCEDURE



15. Remove lower bolts on crossmember and remove cross member extensions both sides as shown, set aside these will not be reused



16. Remove plastic plugs in chassis holes in 4 places, inside and outside chassis in the area shown



17. Fit bracket mounting assembly to front of vehicle using the 6 x 10mm studs to locate on. Snug up only do not tighten.

ARROWS INDICATE STUDS  
ON LHS OF VEHICLE

## FITTING PROCEDURE

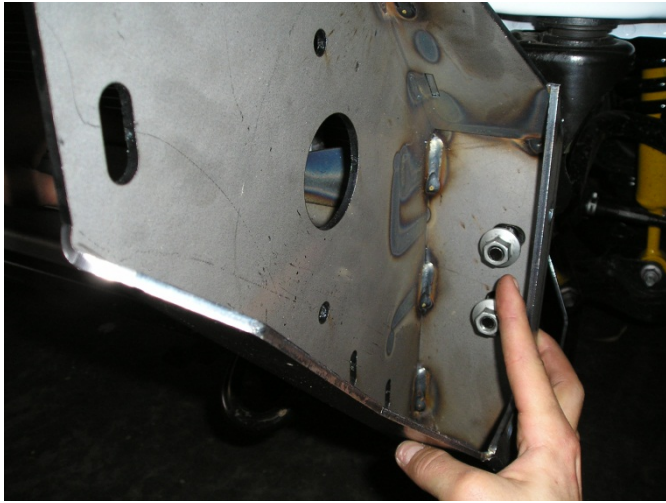

18. Fit original 10mm nuts to the outside fixing points. Snug up only do not tighten.



19. Fit M10 x 1.25P nuts (***fine thread***) spring washers and flat washers ( from bull bar bolt kit ) to both of the centre studs. Snug up only do not tighten.

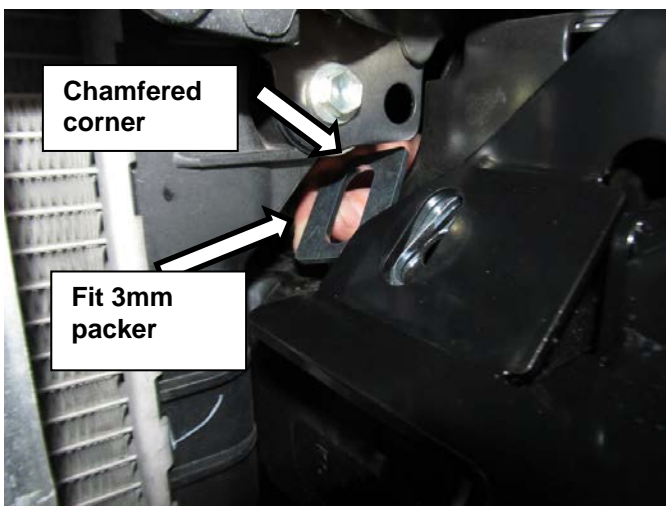

20. Fit 3mm packers as shown



## FITTING PROCEDURE

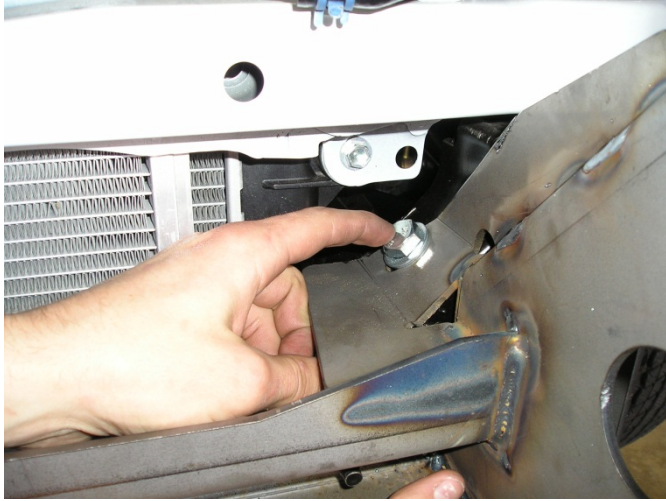

21. Fit M12 x 1.25P x 35mm ***(fine thread)*** bolt, 12mm flat washer through top rearward bracket passing through body mount. Repeat for other side of vehicle

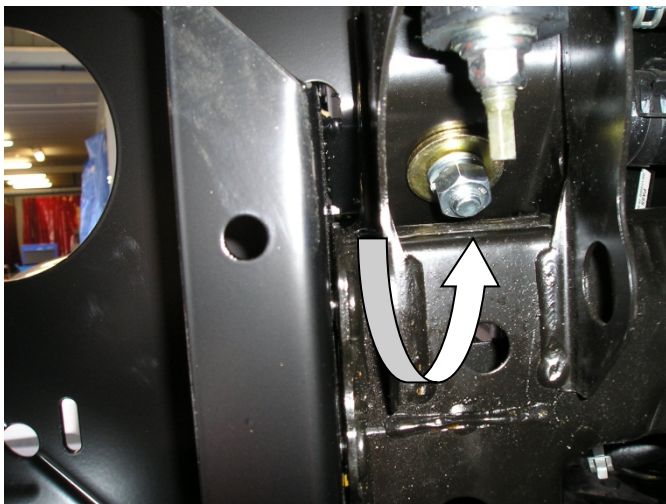

22. Secure from underneath using large M12 flat washer, spring washer and nut. Repeat on other side of vehicle. Snug up only do not tighten.

**See Photo:**

PHOTO VIEWED FROM UNDER  
LHS OF VEHICLE

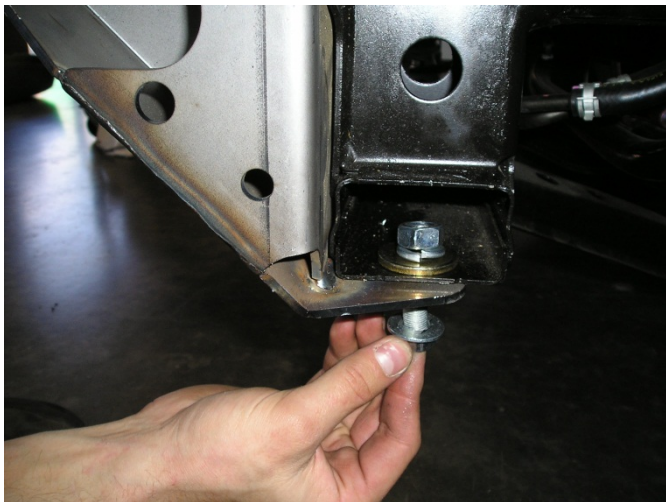

23. Secure lower fixing point by fitting M12 bolt, flat washer from underneath and secure from the top using large M12 flat washer, spring washer and nut ***(fine thread)*** to each side of vehicle. When all bolts are fitted, tighten

 M10 = 44 Nm.

 M12 = 77 Nm.

## FITTING PROCEDURE

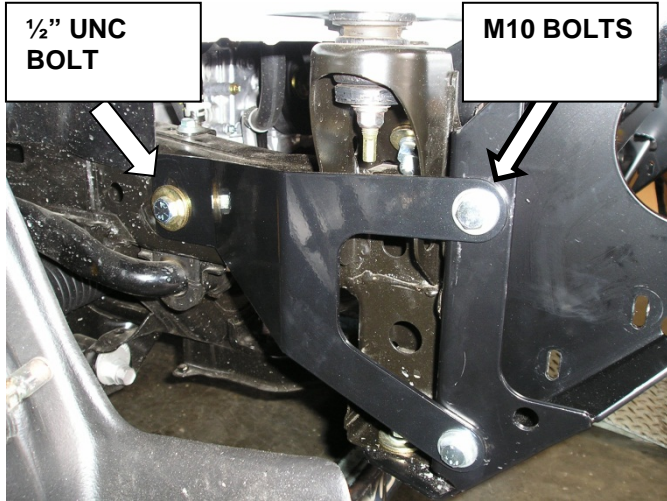



PHOTO IS OF RHS OF VEHICLE

24. Lastly fit tension brackets to each side of vehicle. The two front fixing bolts are M10 x 30mm flat washers, spring washers and M10 nuts. The rear bolt is 4" x 1/2" UNC which is passed through the chassis from outside of vehicle and fitted with a large M12 washer and a 1/2" UNC Nyloc nut on the inside of vehicle. When all bolts are fitted, tighten front bolts  M10 = 44 Nm. tighten rear 1/2" UNC bolt to a torque setting of  44 Nm.



25. Fit buffers to bar and secure from inside of bull bar using M6 flange nuts. Six to each side of vehicle.

**DO NOT OVER TIGHTEN**

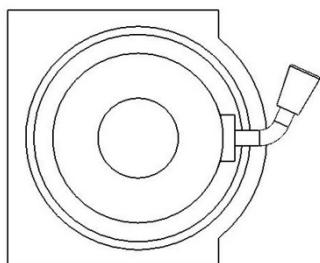

ORIGINAL

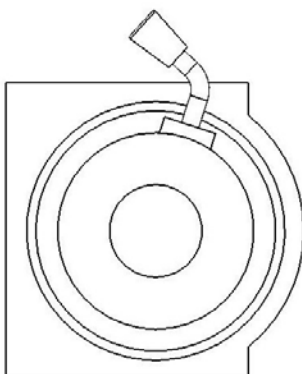

VIEWED FROM  
LHS OF VEHICLE

ROTATED

### TO FIT A WINCH BAR

26. To fit an 8/9/9,500lb winch, rotate gearbox 72° counter clockwise.
- Stand winch upright and undo the capped head screws and by lifting the gearbox only a couple of millimetres, rotate the gearbox. Once in position, refit all screws and tighten firmly.

**WARNING: Do not lift gearbox more than a couple of millimeters.**

## FITTING PROCEDURE

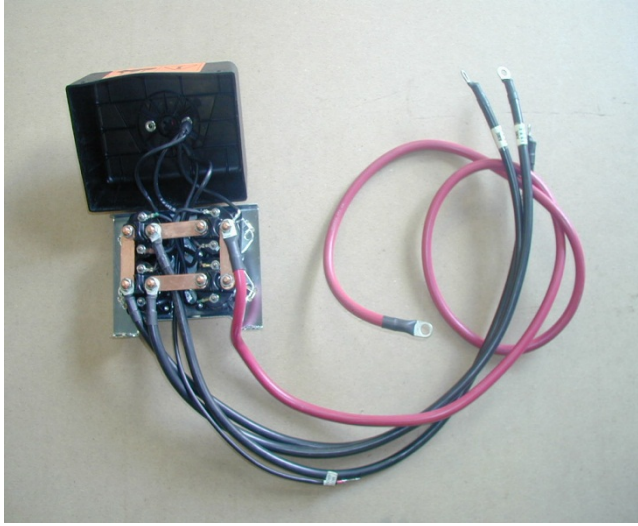

27. Remove the cover from the control box.
28. Replace the three main power cables that go from winch to control box. Make sure that you identify the colour codes on the new cables before closing control box cover.

***NOTE: This must be done for whatever winch is to be fitted to the bull bar.***

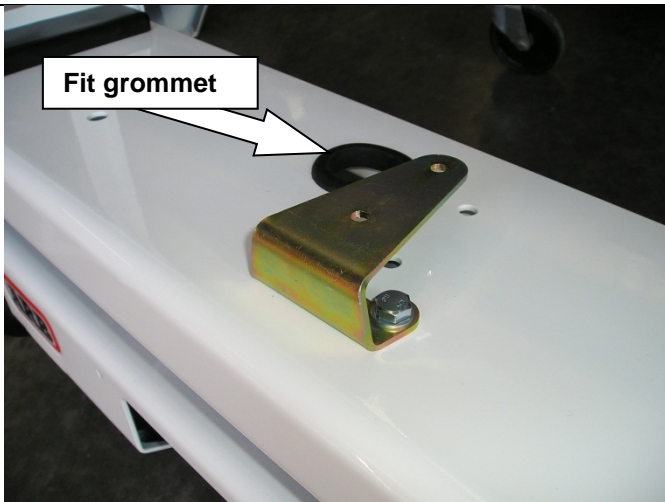

29. Bolt control box bracket to top of bar using 8mm hardware.
30. Fit rubber grommet to RHS of bar.

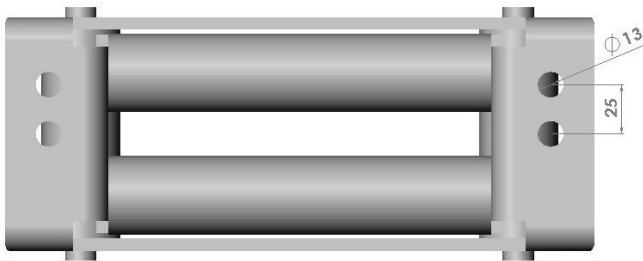

31. Drill two new 13mm holes in the roller fairlead provided in the kit, as shown on the adjacent picture.



**Warning: Drilling operations can result in flying metal debris, safety glasses should be worn.**



## FITTING PROCEDURE



32. Place the winch on a table with the feet facing up and using an assistant; carefully lift the bull bar on top of the winch.
33. Attach the winch to the bull bar using two 1 ½" x 3/8" bolts from the winch fitting kit, 3/8" spring washer and 3/8" flat washers in the top holes.



34. Position the roller fairlead, and remove the circlips from the lower of the vertical rollers and push the pins up to give access to the lower bolts.
35. Fix the roller fairlead to the bar using the 1 ¾" x 3/8" bolts, spring and flat washers.



36. When all bolts are fitted, tighten to  3/8" = 44 Nm.
37. Refit vertical roller pins back into roller fairlead and refit circlips.

## FITTING PROCEDURE

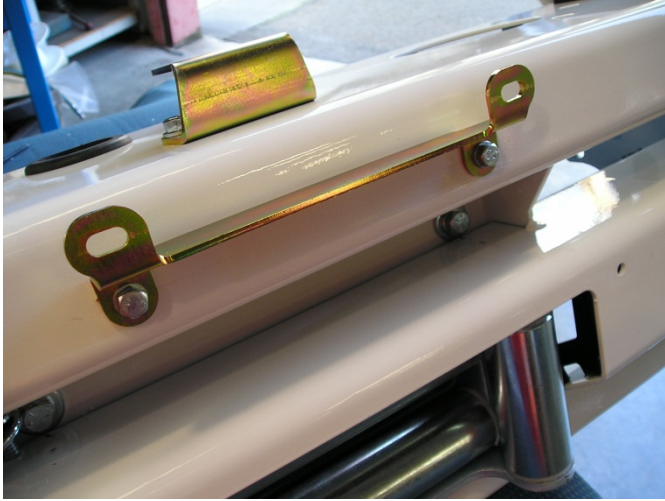

38. Fit number plate bracket to bar using 6mm hardware. Tighten to



M6 = 7 Nm.



39. Fit control box to control box bracket and pass cables through rubber grommet.

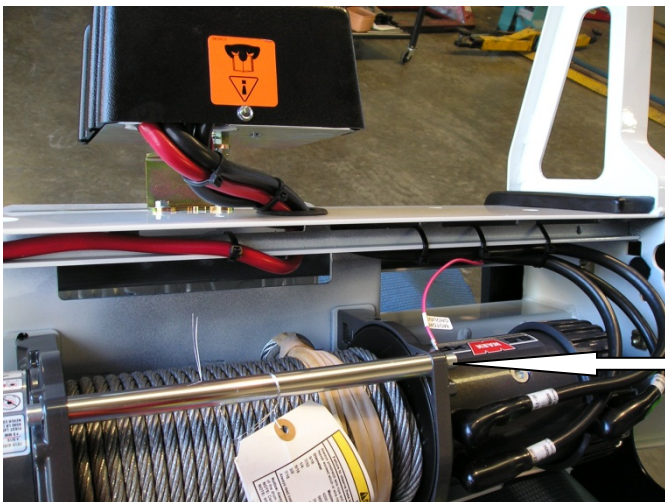

40. Fit all 3 cables to their correct terminals and tighten. Refer to Warn installation instruction when wiring up winch. Fit plastic boots over terminals. Cable tie cables to brace as per photo to clear of all moving parts. Fit ground wire under winch tie rod. ( See Photo )

GROUND WIRE



## FITTING PROCEDURE

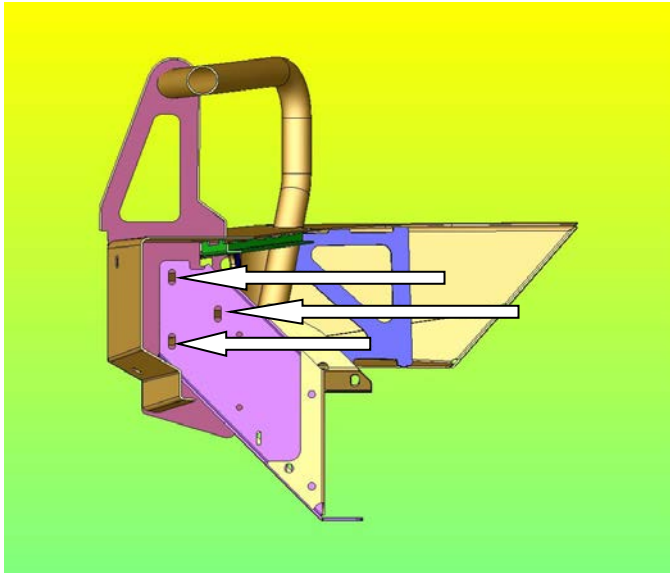

41. With the help of a friend, lift bull bar on to chassis mount bracket and align slots in mount
42. Secure using M10 x 30mm SEMS bolts, M10 flange nuts, do not fully tighten.

ARROWS INDICATE WHICH HOLES TO USE IN SECTION VIEW DRAWING

SECTION VIEW IS LHS OF VEHICLE.



43. Align bull bar so there is a 15mm to 18mm gap from tops of wings to underside of flares and an even 10mm minimum gap to vehicle including periphery under front vehicle panels, and then tighten all bolts.
44. If the bull bar is not central on the vehicle loosen the mount bolts to the chassis, remove the 3mm packers and adjust bull bar position, add packers as appropriate and retighten all fasteners as specified.

 M10 = 44 Nm.

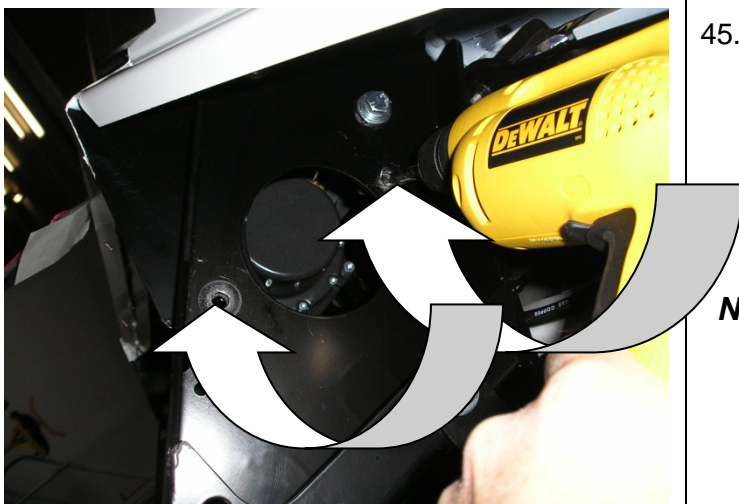

45. Finally, using the existing 2 holes as a guide, drill through using a M10 drill bit and secure using two M10 SEMS and M10 flange nuts, tighten to

 M10 = 44 Nm.

**NOTE: These bolts are to lock the bull bar to the chassis mounting bracket**



**Warning: Drilling operations can result in flying metal debris, safety glasses should be worn.**



## FITTING PROCEDURE



47. Assemble and install combination light surrounds (p/n 3163015) as per instructions no. 3786421 supplied with surround kit.
48. Replace 25W bulbs with supplied 10W bulbs to indicator sockets only in both lamp assemblies

**Note: Optional fog lamps can be installed at this point as per fitting instruction no. 3783315 supplied with fog lamp kit no. 6821201.**

FUNCTION	INDICATOR HARNESS	VEHICLE COMBINATION LAMP	
		RIGHT	LEFT
INDICATOR	GREEN	BLUE	YELLOW
EARTH	BLACK	WHITE/BLACK	WHITE/BLACK
PARK LAMP	RED	GREEN	GREEN

49. Fit indicator/parker light loom extension to light and wire to vehicle main light loom using scotch locks as per table.

**Caution: Cable tie all cables together and keep all cables clear of sharp edges and moving parts.**

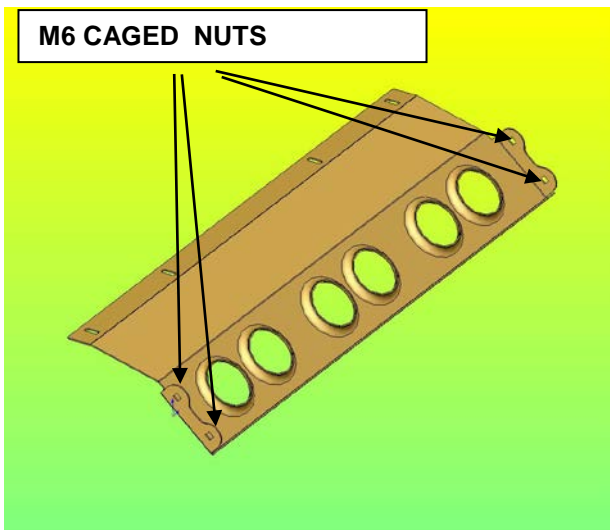

50. Fit M6 caged nuts to the inside of the flanges on the splash pan.

## FITTING PROCEDURE



51. Fit splash pan to lower flange of bull bar using M6 x 20mm bolts, spring washers and large flat washers. Snug up only.

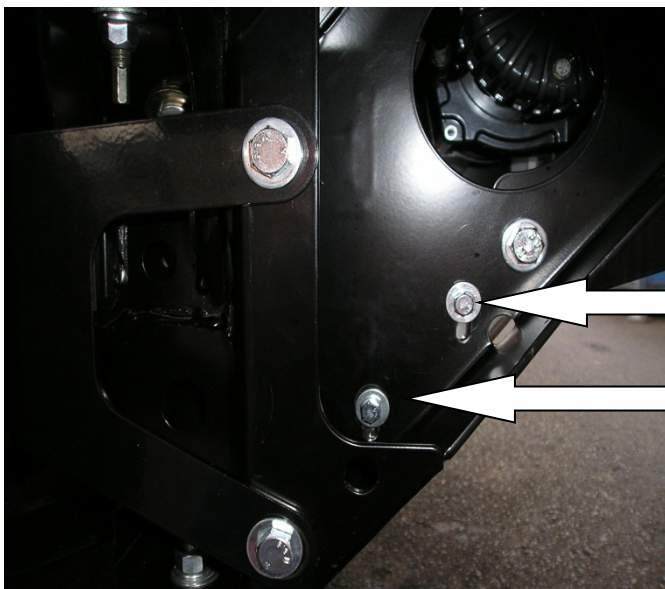

52. Fit side bolts for splash pan to bull bar mount sides using M6 x 20mm bolts, spring washers and large flat washers. Snug up only.
53. When all bolts are fitted, tighten



M6 = 7 Nm.

ARROWS INDICATE M6 BOLT POSITIONS



54. Fit number plate to number plate bracket using M6 hardware



M6 = 7 Nm.

55. Driving lights can be fitted at this stage and can be tighten using a ratchet and socket which fits through the gap as per arrow

## FITTING PROCEDURE

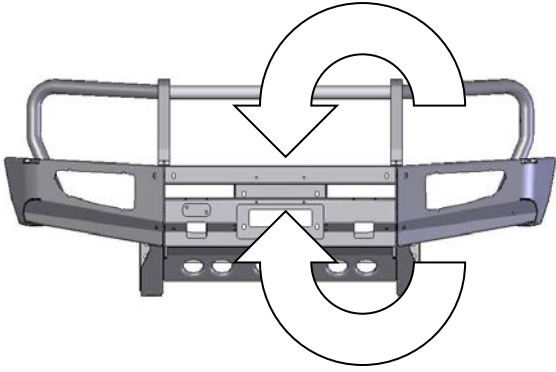

56. There are two positions for the number plate to be fitted to the bull bar.
57. Top arrow is position to bolt number plate for a winch bar.
58. Lower arrow is position to bolt number plate for a non-winch bar.



59. There is a provision on both sides of bar for a HiLift to be used.

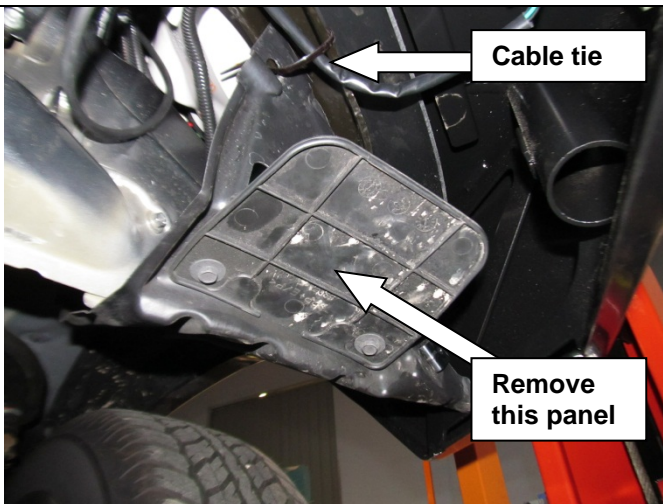

60. Pull fender liner up inside bull bar wing area and cable tie vehicle bumper crossmember as shown.
61. Remove panel if shown if required



## FITTED PRODUCT

