

ARB **BASE RACK**

FITTING INSTRUCTION

Part Number:
17913010

Suits BASE RACK:
1770060/1770070

Product Description: **BASE RACK Suits Tacoma 16on**

WARNING

NOTE THE FOLLOWING:

- ◆ Vehicle accessories which are not properly fitted can be dangerous.
- ◆ Please read these instructions carefully prior to fitting, and comply with the instructions at all times
- ◆ If in any doubt please contact your nearest ARB state office or the stockist from whom it was purchased
- ◆ Do not use this product for any vehicle make or model, other than those specified by ARB
- ◆ This product or its fixing must not be modified in any way
- ◆ The installation of this product may require the use of specialized tools and/or techniques
- ◆ It is recommended that this product is only installed by trained personnel
- ◆ These instructions are correct as at the publication date. ARB Corporation Ltd. cannot be held responsible for the impact of any changes subsequently made by the vehicle manufacturer
- ◆ During installation, it is the duty of the installer to check correct operation/clearances of all components
- ◆ Work safely at all times
- ◆ Unless otherwise instructed, tighten fasteners to specified torque
- ◆ Check bolt torque after 500km & at regular service intervals

ARB 4x4 ACCESSORIES

Corporate Head Office

42-44 Garden St
Kilsyth, Victoria
AUSTRALIA 3137

Tel: +61 (3) 9761 6622
Fax: +61 (3) 9761 6807

Australian enquiries
North & South American enquiries
Other international enquiries

sales@arb.com.au
sales@arbusa.com
exports@arb.com.au

www.arb.com.au

SAFETY

NET PAYLOAD FOR YOUR BASE RACK

The net payload for your BASE RACK is calculated by subtracting the weight of the BASE RACK and the vehicle mounting kit from the vehicle's roof capacity. The table below gives the BASE RACK net payload for fitting kit 17913010, using the vehicles maximum vehicle roof capacity. The vehicle's roof load capacity may vary between models and driving conditions. Refer to vehicle owner's manual for model and condition specific roof load capacities.

Kit	BASE RACK	Vehicle roof capacity* (kg/lb)	BASE RACK + mount kit (kg/lb)	BASE RACK net payload (kg/lb)
17923010	1770060	75/165	20.0 / 43	55/122
17923010	1770070	75/165	21.2 / 46	55/119

* Maximum roof load capacity. Refer to vehicle owner's manual for model and condition specific roof load capacities.

It is important to follow the listed usage instructions;

- ◆ Maximum load per BASE RACK beam is 25kg.
- ◆ Load must be evenly distributed and adequately secured.
- ◆ Any weight carried on the roof of the vehicle will adversely affect its handling, particularly in cornering or in a cross-wind, the vehicle should therefore be driven with increased discretion.
- ◆ Regularly check the tightness of the securing clamps and the security of the load.
- ◆ Attention is directed to statutory requirements regarding maximum permissible projections from vehicles.

All bolts should be checked prior to touring to ensure the BASE RACK is fastened correctly

GENERAL CARE AND MAINTENANCE

By choosing an ARB BASE RACK, you have bought a product that is one of the most sought after 4WD products in the world. Your BASE RACK is a properly engineered, reliable, quality accessory that represents excellent value. To keep your BASE RACK in original condition it is important to care and maintain it following these recommendations:

- As part of any pre-trip preparation, or on an annual basis, it is recommended that a thorough visual inspection of the BASE RACK is carried out, making sure that all bolts and other components are torqued to the correct specification. Replace any components as necessary.

Please contact local Authorised ARB Stockist if you would like to have this service carried out on your behalf.

FITTING REQUIREMENTS

REQUIRED TOOLS FOR FITMENT OF PRODUCT:

10mm spanner x 2	13mm spanner x 1
Allen key set	T40 Torx key (provided)
Pen/pencil	Socket set
Tape measure	

For BASE RACK lightbar fitment only

Tinsnips or angle grinder	Black touch-up paint
---------------------------	----------------------

NOTE: 'WARNING' notes in the fitting procedure relate to OHS situations, where to avoid a potentially hazardous situation it is suggested that protective safety gear be worn or a safe work procedure be employed. If these notes and warnings are not heeded, injury may result.





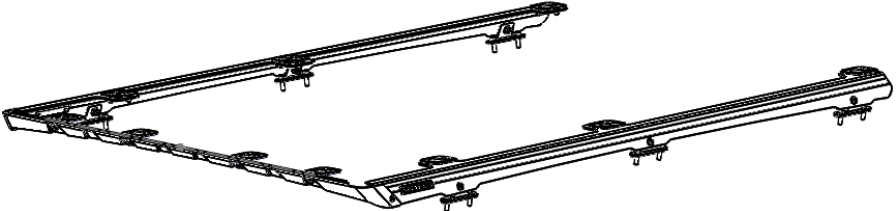

FASTENER TORQUE SETTINGS:

SIZE	Torque Nm	Torque lbft
M6	9Nm	7lbft
M8	22Nm	16lbft

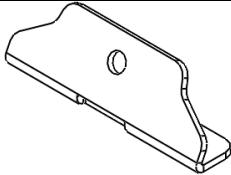
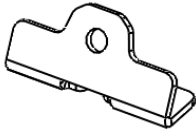
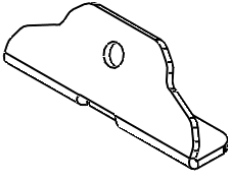
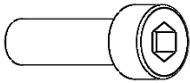

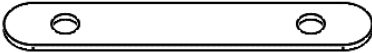

PARTS LISTING - BASE RACK & air deflector fitting kit

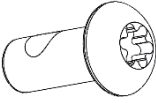
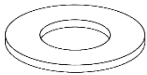
PART NUMBER	SUITS BASE RACK	QTY	DIAGRAM
17923010	1770060 / 1770070	1	





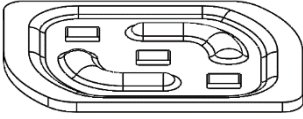
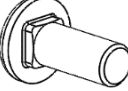



PARTS LISTING

PART NO.	PICTURE	QTY	DESCRIPTION
APPLICATION – MOUNTING BRACKETS TO ROOF			
3750996		2	REAR MOUNTING BRACKET W/ WELD NUT 73MM
3750995		2	MID MOUNTING BRACKET W/ WELD NUT 35MM
3750994		2	FRONT MOUNTING BRACKET W/ WELD NUT 55MM
6151588		12	M6 X 1 X 20MM SOCKET HEAD CAP
4584425		12	M6 WASHER FLAT - BONDED
5848447		2	REAR RUBBER PACKER 73MM
5848510		2	MID RUBBER PACKER 35MM
5846403		2	FRONT RUBBER PACKER 55MM
6151934		1	TORX ALLEN KEY
6151924		6	M8 X 1.25 X 20 BUTTON HEAD TORX - BLK
4581085		6	M8 WASHER FLAT - BLACK

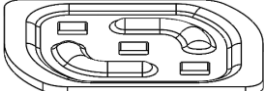
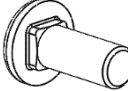
APPLICATION – BASE RACK TO MOUNTING BRACKETS

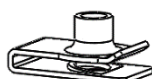
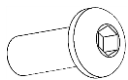
3750993R		1	BRKT BLADE BASE RACK TACOMA RH
3750993L		1	BRKT BLADE BASE RACK TACOMA LH
3195184		4	M8 STUD PLATE
6151921		8	M8 X 20 STUD - BLACK
6151212		8	M8 X 1.25 NYLOC NUT - BLACK
4581085		8	M8 WASHER FLAT – BLACK

APPLICATION – AIR DEFLECTOR TO BASE RACK

3750528		1	AIR DEFLECTOR
3752747		4	AIR DEFLECTOR MOUNT BRACKET
3195184		4	M8 STUD PLATE
6151921		4	M8 x 20 STUD - BLACK
6151212		4	M8 x 1.25 NYLOC NUT - BLACK
4581085		4	M8 FLAT WASHER - BLACK
6151475		4	U-NUT M6
6151459		6	M6 x 16 BUTTON HEAD HEX - BLACK
4584329		8	M6 FLAT WASHER - BLACK
6151223	NOT REQUIRED 	2	M6 x 1.0 NYLOC NUT - BLACK
4581082	NOT REQUIRED 	2	M6 FLAT WASHER LARGE - BLACK

BEFORE STARTING, READ ALL STEPS OF THE INSTRUCTIONS CAREFULLY AND CHECK ALL PARTS

STEP 1: REMOVAL OF CHANNEL COVERS



1. Access the 6 mounting points by removing the factory rails (if installed) or removing the trim as below
2. Remove the gutter trim by slowly peeling. Keep the strips

3. Find the 5 holes on each side, covered by sealing pads (2 front, 1 middle, 2 rear)
4. Cut an X in the sealing pad over each hole to access

NOTE: Be careful not to scratch the surrounding paint work.

STEP 2 – ATTACH MOUNTING BRACKETS TO ROOF

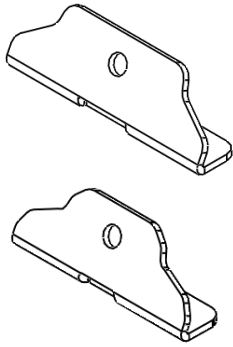

- Match the front and rear mount bracket to the roof position based on hole pitch

Check for wrinkles/flatness

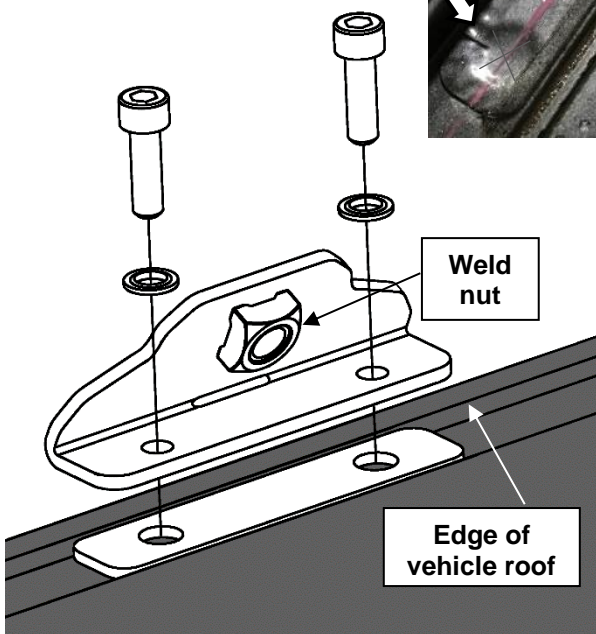

- Check if the surface of the sealing tape around the holes are flat. If not, apply a small amount of silicone to aid sealing before step 7
- Place a rubber packer over each of the sets of holes in the roof channels
- Position the mounting bracket so the weld nut is facing towards the centre of the vehicle. Attach each bracket to the roof mounting points using M6 Socket head screws and M6 Bonded washers. See image.

Tighten screws to specified torque

 **Torque M6 to 9Nm/7ft-lb**

Rear of vehicle

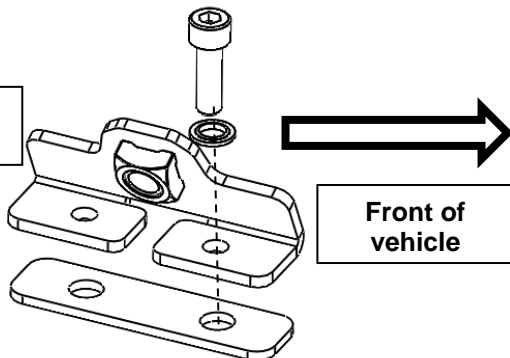

- Fit the centre mount bracket to the vehicle roof central mount hole using the mount hole closest to the front of the vehicle (i.e. the bracket will sit slightly to the rear of the mount)

Generic Image

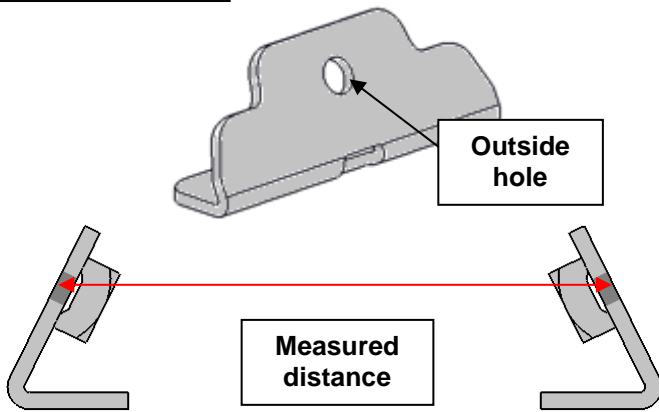

10. Using a tape measure, measure across the vehicle between the middle of the hole on the outside face of the front and rear set of mounting brackets. Make a note of each measurement.

Position	Distance
Front	
Rear	

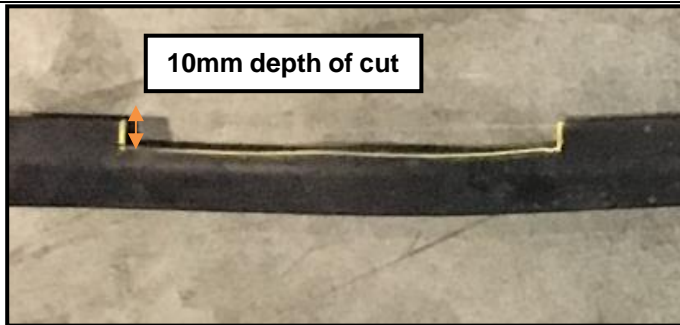

11. Lay the rubber gutter trim against the installed brackets and mark the bracket location and screw head interference

12. Trim the top section of rubber to fit around the brackets

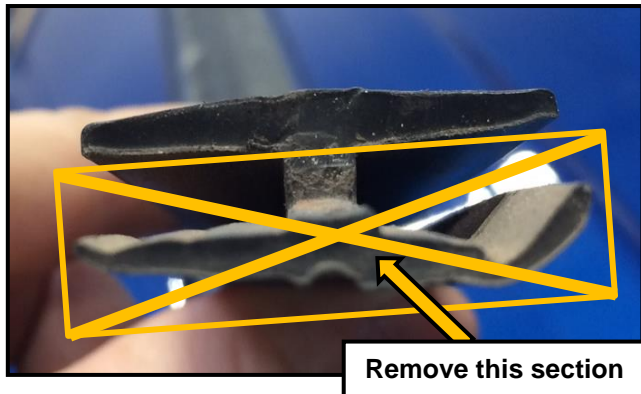

13. Trim the lower section only to clear screw heads (shown)

14. Check the trim fits without interfering

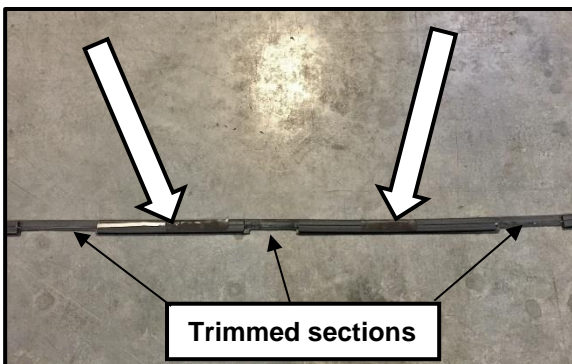

15. Clean the bottom of the trim

16. Apply the adhesive tape in the area between the mount brackets

17. Reinstall the trim

STEP 3 – ASSEMBLE THE BASE RACK

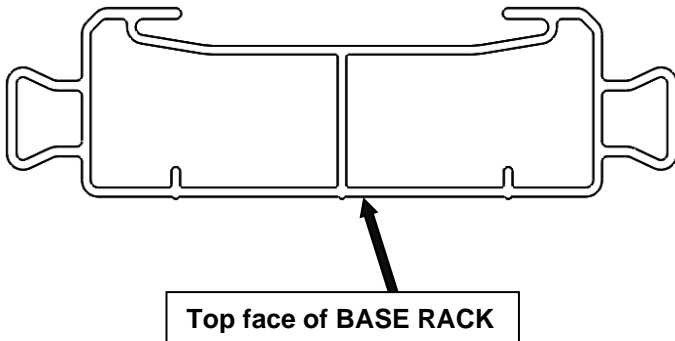

18. Place the BASE RACK face down on a clean flat surface. Provide protection to the top face of BASE RACK to avoid marking of surfaces

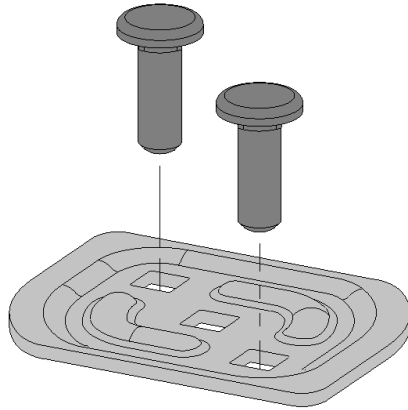

19. Insert 2, M8 x 20 Studs into each of the Stud Plates as shown.

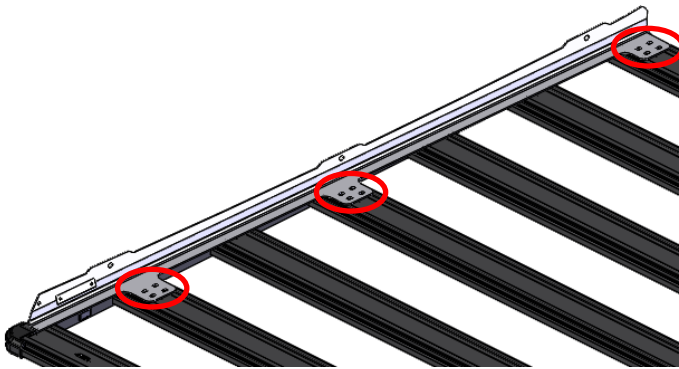

20. Check the position of the mounting plates (circled in image) on the blade brackets in relation to the channels on the BASE RACK.
(6 position mount bolt given in example)

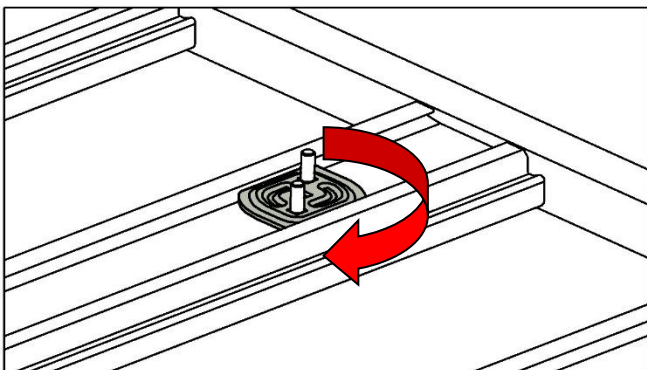

21. Insert the previously assembled stud plates into the correct BASE RACK channels. Rotate the plates 90 degrees.

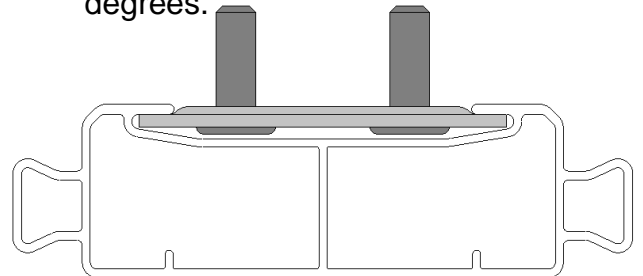

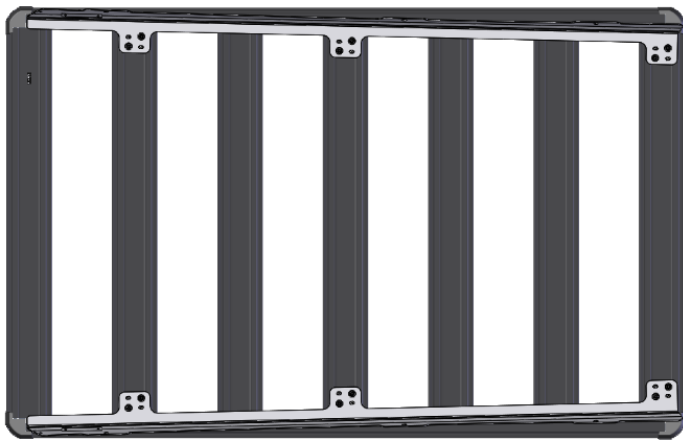

22. Flip the blade brackets over so they are upside down and carefully place on top of the BASE RACK. When doing so ensure the M8 studs in the stud plates go through the slots. Then secure the blade brackets to the BASE RACK using M8 flat washers and nyloc nuts.

Do not fully tighten, allowing blades to move within the BASE RACK channel

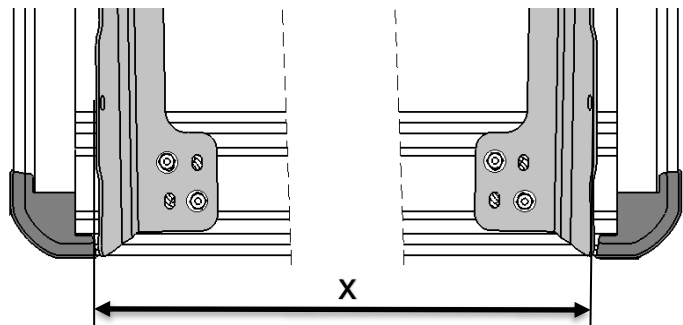
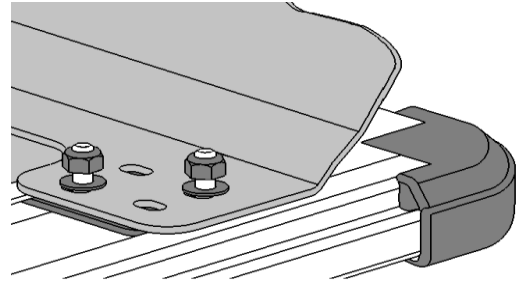

23. Using the previously recorded measurements, adjust the location of the blade bracket on the BASE RACK. Ensure the distance between the blade bracket and the edge of the BASE RACK is the same on both sides. Fully tighten all M8 Nyloc nuts



Torque M8 to 22Nm/16ft-lb

STEP 4: AIR DEFLECTOR FITMENT

STEP 1 & 2 ARE ONLY FOR FIT OF OPTIONAL LIGHT BAR 1780500

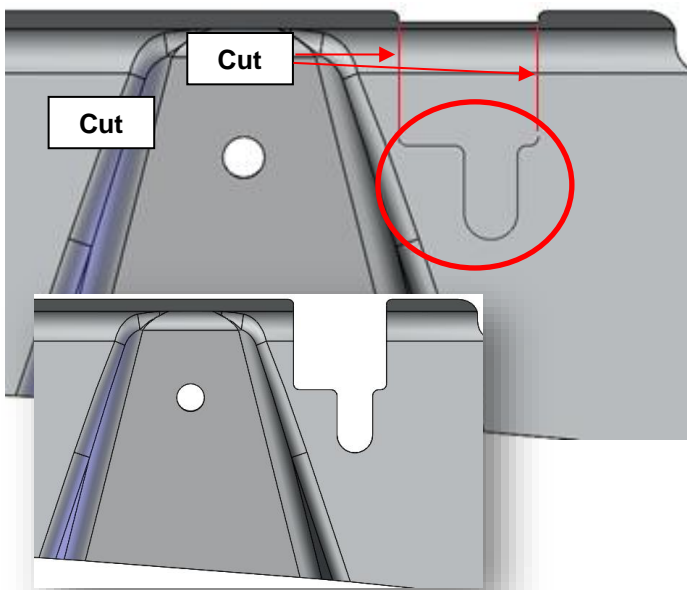

FOR LIGHT BAR ONLY:

1. If fitting the air deflector together with a front mounted BASE RACK Light Bar, the Air Deflector needs to be modified as described below. Refer to the instructions provided with the BASE RACK light bar for details on installing the light bar.
2. Make 4 cuts in the air deflector between the notches in the top edge and the laser cut shape as shown.

Discard the material removed.

Remove any sharp edges and paint raw edges with black touch-up paint.

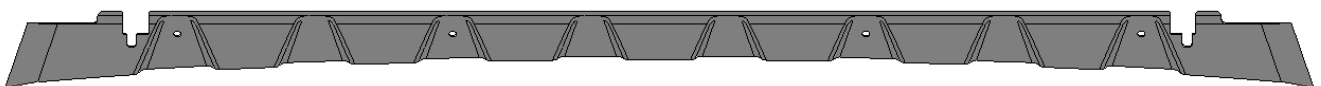

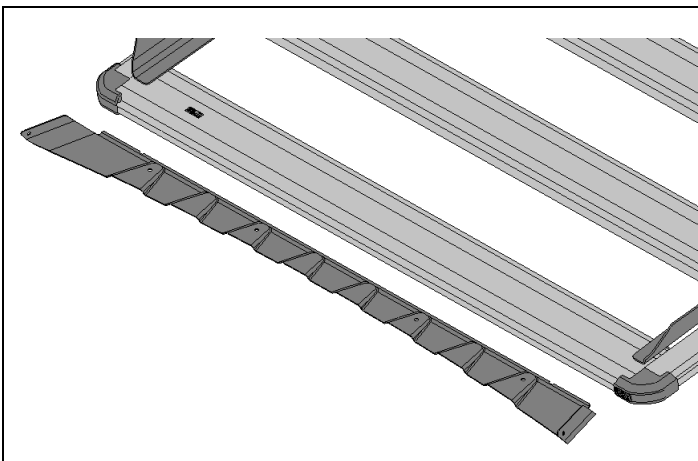

Note: BASE RACK should be upside down with the vehicle mount brackets fitted.

3. Lay the air deflector face down, parallel with the front of the BASE RACK. This will help determine the general position for the stud plates. Ensure the distance between the end of the deflector and outside of the tray is the same on both sides.

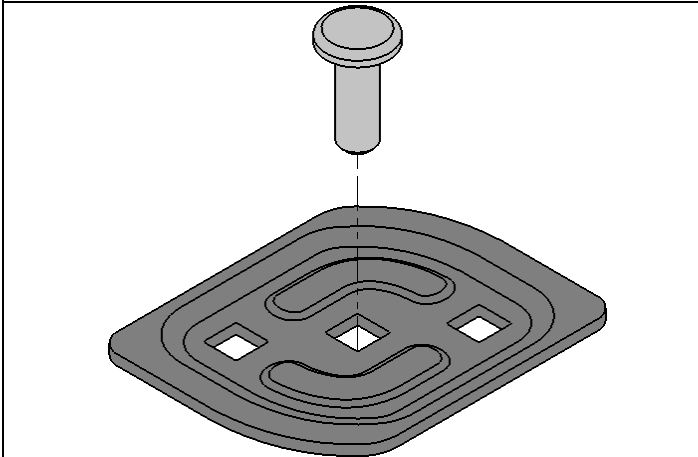

4. Insert one M8 Stud into each of the Stud Plates as shown.

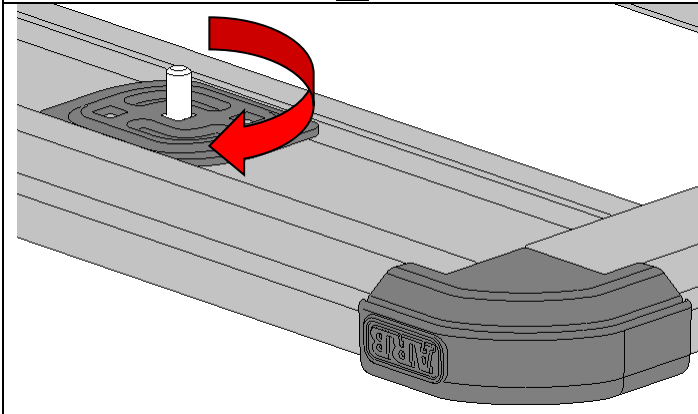

5. Flip the plate over and insert each of the 4 assembled stud plates into the front channel of the BASE RACK. Rotate 90 degrees and ensure the axis of the bolt lines up with the holes in the air deflector.

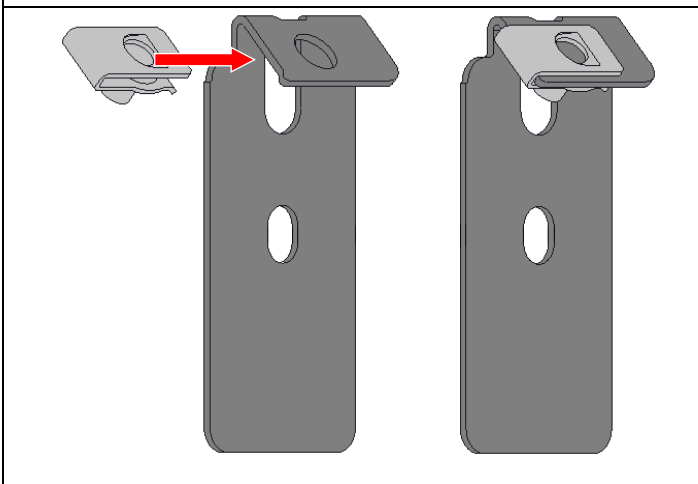

6. Snap one u-nut onto each of the 4 air deflector mounting plates. Take care to ensure the u-nut is oriented correctly. See image.

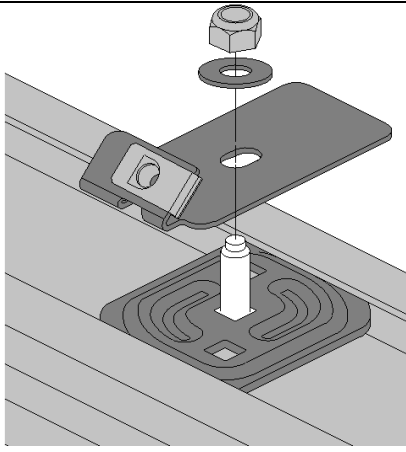

7. Attach the air deflector mounting plates to the stud plates with an M8 flat washer & nyloc nut.
- Leave nut loose enough to allow assembly to slide along channel.

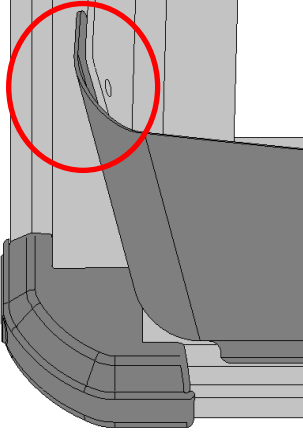

8. Flip the air deflector over and offer it up to the assembled BASE RACK and blade brackets.
- Ensure the folded ends of the deflector are outside the ends of the blade brackets. The holes in the front of the air deflector should line up closely with the u-nuts

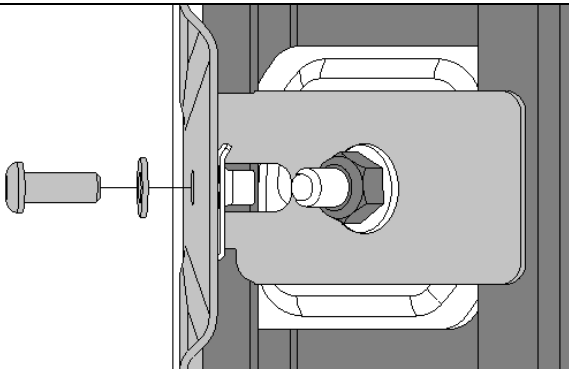

9. Secure each of the 4 mounting plates to the air deflector. Use the M6 Button head screws and black M6 washer (part# 4584329) as shown.
10. Tighten all screws to specified torque.

 Torque M8 to 22Nm/16ft-lb

 Torque M6 to 9Nm/7ft-lb

11. Fitted



Fitted with Lightbar (in front of deflector)

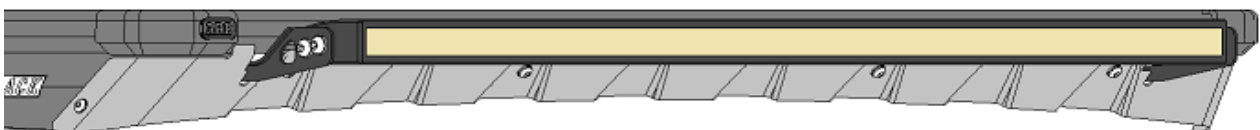

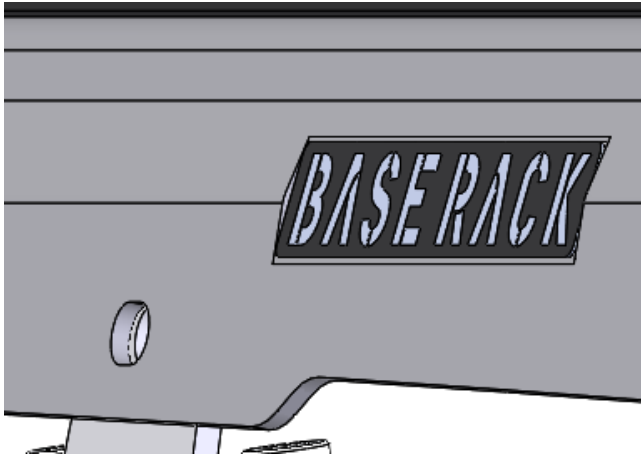

24. With assistance, carefully place the BASE RACK on the vehicle so the inside of the blade brackets rests on the outside of the mounting brackets. The entire BASE RACK assembly should be clear of the vehicle roof. All mounting holes/slots should align closely.

Note: Place protective material on roof to reduce the risk of accidental damage to vehicle when mounting the BASE RACK to the vehicle.

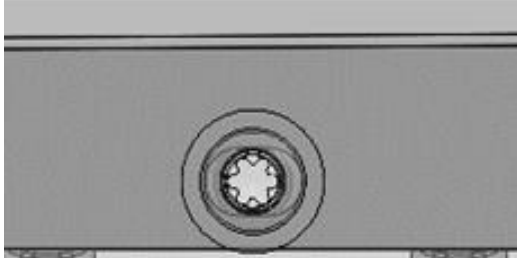

25. Confirm BASE RACK is correctly aligned to vehicle. If it is not it is recommended to remove the BASE RACK from the vehicle roof and repeat the mounting process from the measurement step.

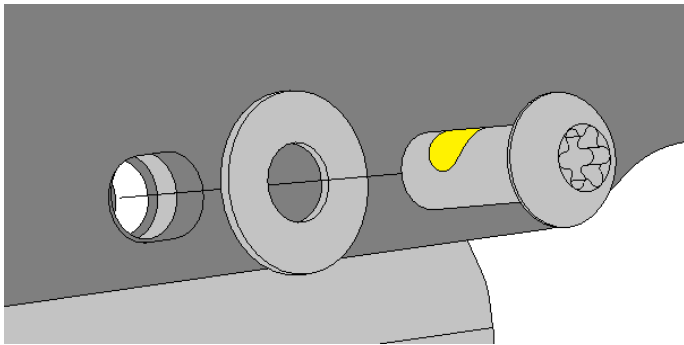

26. Use the M8 Button head Torx screws and M8 Black washers to secure the BASE RACK to the roof mounting brackets. Tighten all screw to the specified torque.



Torque M8 to 22Nm/16ft-lb

Fitted to Vehicle:

