



ARB FRIDGE FREEZER SERVICE MANUAL ELEMENTS

Model	60L (63 qt)
Type	10800050
Date	April 2021

TABLE OF CONTENTS

1	INTRODUCTION	2
1.1	General information.....	2
1.2	How to use this manual.....	2
1.3	Contact information.....	2
2	WARRANTY.....	3
2.1	ARB Fridge Freezer Limited Warranty.....	3
2.2	Warranty procedure for service agents.....	4
2.3	Warranty Approval Form.....	5
3	STANDARD SERVICE/WARRANTY TIMES.....	6
4	SPARE PARTS.....	7
4.1	Spare parts list.....	7
4.2	Spare parts exploded drawing.....	8
4.3	Minimum stocked spare parts.....	9
5	TOOLS REQUIRED	10
5.1	Basic servicing.....	10
5.2	Servicing the refrigeration system.....	10
6	TROUBLESHOOTING.....	11
6.1	Check (diagnosis) lights.....	11
6.2	DC Power Supply.....	12
6.3	AC Power Supply.....	16
6.4	Cooling.....	17
6.5	General.....	20
6.6	Battery Protection Settings.....	21
7	FAULT FINDING FLOW CHARTS.....	22
7.1	Fridge will not run on 100-240V AC power.....	22
7.2	Fridge will not run on 12/24V DC power.....	23
8	CHECKS AND TESTS.....	24
8.1	Vehicle wiring system.....	24
8.2	Test compressor control unit – 12/24V DC.....	27
8.3	Test main circuit board – 100-240V AC.....	29
8.4	Test compressor control unit – 100-240V AC.....	31
8.5	Test compressor.....	33
8.6	Test thermistor.....	34
8.7	Adjust internal temperature correlation.....	35
9	SERVICE.....	36
9.1	Control panel circuit board – Remove and Replace.....	36
9.2	Control panel – Drain hole modification.....	38
9.3	Rear Cover – Remove and Refit.....	39
9.4	Compressor control unit - Replace.....	40
9.5	Main circuit board - Replace.....	42
9.6	Rear Cover – Replace.....	44
9.7	Cooling fan - Replace.....	47
9.8	LED - Replace.....	49
9.9	Plug fuse (12/24V DC) - Replace.....	50
9.10	Device fuse (100-240V AC) - Replace.....	51
9.11	DC power socket - Replace.....	52
9.12	AC power socket - Replace.....	53
9.13	Rubber feet – Remove and Refit.....	54
9.14	Compressor mounting feet – Replace.....	55
9.15	Compressor mounting base - Replace.....	57
9.16	Lid seal – Remove and Refit.....	59
9.17	Thermistor – Replace.....	60
9.18	Hinge – Remove and Refit.....	63
9.19	Lock Assembly – Remove, Inspect and Refit.....	64
9.20	Factory Reset – Lock Password Reset.....	65
10	SERVICE BY REFRIGERATION MECHANIC.....	67
10.1	Compressor recharge information.....	67
10.2	Leaks in the refrigerant system.....	67
11	WIRING.....	68
11.1	Wiring diagram.....	68
11.2	Wiring schematic – Main Circuit Board.....	69
11.3	Wiring schematic – Display Circuit Board.....	70

1 INTRODUCTION

1.1 General information

This manual is for the sole use of ARB approved repairers and provides information on servicing the ARB Elements Fridge Freezer (type 10800050). The part numbers covered by this manual include 1081060X.

Deviation from the directions given in this manual are not permitted without the express permission of the ARB Fridge Freezer Product Manager or the ARB Warranty Manager.

If you have any queries about servicing an ARB Fridge Freezer, please contact ARB using the contact details below.

This manual makes reference to working with mains power in the range from 100-240V AC. All electrical work of this nature must be carried out by a qualified electrician.

This manual makes reference to working with the refrigeration system of the fridge freezer. All work involving the refrigeration system must be carried out by a qualified refrigeration mechanic.

Please note that safe working practices must be exercised while performing any work on an ARB Fridge Freezer.

1.2 How to use this manual

This manual has been developed as an electronic resource. To navigate through this manual, click on the [blue underlined](#) reference links.

Throughout this manual, reference is made to replacement parts. All spare parts are available from ARB. A complete list of spare parts and corresponding part numbers is given in section [4.1](#) of this manual. Please note that individual part numbers are not listed elsewhere within this manual.

The following terms are used throughout this manual:

CAUTION: These are instructions given to prevent damage or accidents.

HINT: These are helpful suggestions to aid the servicing procedure.

NOTE: These are details which may further clarify a situation.

WARNING: These are safety warnings. Failure to observe these instructions can cause personal injury or damage to the fridge.

1.3 Contact information

ARB 4x4 ACCESSORIES
Corporate Head Office

42-44 Garden St
Kilsyth, Victoria
AUSTRALIA
3137

Tel: +61 (3) 9761 6622
Fax: +61 (3) 9761 6807
Web: www.arb.com.au

Australian enquiries
North and South American enquiries
Other international enquiries
European Enquiries

sales@arb.com.au
sales@arbusa.com
exports@arb.com.au
purchasingeu@arb.com.au

2 WARRANTY

2.1 ARB Fridge Freezer Limited Warranty

ARB Corporation Ltd's Fridge Freezers are warranted to be free from material and workmanship defects for a period of thirty six (36) months from the date of initial retail purchase.

ARB Corporation Ltd's obligation under the warranty shall be limited to repairing, replacing or crediting at its option any part found to be defective due to faulty workmanship or materials at time of manufacture.

The warranty does not cover:

1. Light LED after 3 months from the initial purchase date.
2. Damage caused as a result of a connection to an incorrect or fluctuating voltage supply.
3. Damage which in the opinion of ARB is caused by faulty installation, normal wear and tear, misuse, water, dirt, neglect, modification made during installation, accident or other similar causes.
4. Removing screws or otherwise opening the outer case, control panel or tampering with the working components of the fridge by any non-authorized ARB repairer.

ARB does not accept responsibility for:

1. Liability in respect to loss or expenses arising from the malfunction of this appliance.
2. Repairs or modifications to an appliance that have been carried out by a non-authorized ARB Service Outlet or person.
3. Transport charges or damage which may be incurred during transit to or from an authorized ARB Service Outlet.

It is the responsibility of the owner to deliver and pick up the appliance from the place of service.

ARB reserves the right to change the warranty conditions at any time by public notice and by attaching a clear change of warranty terms and conditions notice to the product visible at time of purchase. No party other than ARB Corporation Ltd is authorized to change the terms or conditions of this warranty.

Subject to conditions as defined by the Australian Trade Practices Act 1974 (as amended). There are no other warranties either expressed or implied, which extend beyond those set forth in the preceding paragraphs.

2.2 Warranty procedure for service agents

The following procedure should be followed when processing a warranty claim.

1. Make sure that the customer has completed the non-warranty checklist as listed in the warranty statement that was supplied with the fridge freezer.
2. The Fridge Freezer should be received with all components, including all power leads. A physical inspection of the unit should be conducted to ascertain whether there is any damage (eg: scratches, dents, stain, etc), and documented on the application.
3. Assess the fridge to identify the fault(s).
4. Complete a copy of the warranty claim form (refer to section [2.3](#)) and forward it to your regional ARB Office. To be processed, the form must include the customer's details, serial number, a description of the fault, and the parts required.

NOTE: A copy of the purchase receipt must be submitted with the claim.

5. ARB will assess the claim and if approved will dispatch the required parts as soon as practical at no charge to the repairer. If the claim is not approved, ARB will contact the repairer. ARB will also issue the repairer with a Warrant Claim Number and provide any special instructions for repair or return of faulty parts.
6. The repairer shall replace the specified components as per the service manual and test the ARB Fridge Freezer prior to its return to the customer. It is the responsibility of the repairer to warrant the workmanship of the repair for the minimum period as set out in legislation for the jurisdiction in which the ARB Fridge Freezer has been repaired, or if no period is specified, for a minimum of 90 days.
7. Send an invoice that references the Warranty Claim Number to your regional ARB Office for processing. Any variance to the warranty times as stated in this manual must be approved by ARB.

EXCLUSIONS:

Refer to the Warranty Statement supplied with the fridge.

ARB will not accept liability for transport of the ARB Fridge Freezer to or from the service agent.



ARB Fridge Freezer

2.3 Warranty Approval Form

FRIDGE FREEZER

(ARB Use Only)

Authorised By: _____	Claim Number <input style="width: 100%;" type="text"/>
----------------------	--

Service Agent: _____ Address: _____ Date In: _____	Contact: _____ Phone: _____ Fax: _____ Job No: _____ Date Out: _____
--	--

CUSTOMER DETAILS	
Name: _____ Address: _____ P/Code _____	Phone: _____ BH: _____ MOB: _____ Cust Signature: _____
*NOTE – Pre Warranty Inspection to be completed by customer prior to initiating claim (refer Warranty & Service booklet)	

	FRIDGE DETAILS	
<p>Condition Assessment (mark scratches, dents, etc)</p>	Model No: _____ Purchase Date: _____ Purchased From: _____	Serial No: _____ Receipt No: _____ Copy of Receipt Attached: YES / NO

Notes:				
Returned with: (Tick)	12V Lead	240V Lead	Fridge Bag	Other

CUSTOMERS DESCRIPTION OF FAULT

REPAIRERS ASSESSMENT

PARTS REQUIRED

REPAIR TIME (As Per Service Manual)		TOTAL LABOUR COST	\$	*Please Note An invoice quoting the Claim No. must be submitted to initiate payment of labour costs
---	--	--------------------------	----	---

(ARB Use Only) Replaced parts to be returned for assessment	YES / NO
---	----------

Within Australia Fax to (03) 9721 9096

3 STANDARD SERVICE/WARRANTY TIMES

WORK REQUIRED	INDIVIDUAL WARRANTY TIME*
Compressor – remove and replace **	
Condenser – remove and replace **	
Compressor control unit – remove and replace	1.0 hours
Compressor mounting base –remove and replace	1.5 hours
Control panel circuit board – remove and replace	1.0 hours
Device / plug fuse - replace	0.25 hours
Fan – remove and replace	1.0 hours
Hinge assembly – service	0.25 hours
Inlet power socket - remove and replace	0.75 hours
Latch assembly – remove and replace	0.25 hours
Lid - replace	0.25 hours
Lid seal – remove and replace	0.25 hours
Light LED – replace ***	0.25 hours
Light housing - replace	0.25 hours
Main circuit board – remove and replace	1.0 hours
Power cable – check and replace	0.25 hours
Refrigerant blockage or leak **	1.75 hours
Rubber feet – remove and replace (x 4)	0.25 hours
Thermistor - replace	1.0 hours

* Some warranty times can be negotiable due to unforeseen complexities. Any extension to the standard warranty times must be authorised by ARB.

** These parts are not considered serviceable items. Complete fridge replacement is required.

*** Light LED is only covered under warranty for the first 3 months after the initial purchase date.

ARB will not pay for the removal or replacement of a fridge freezer that has been built in, unless authorisation is given by the ARB.

The warranty labour rate paid will be based on the average refrigeration service rate for the region of the repairer.

Calculating total warranty time

The table above list warranty times for the service of individual components.

If a single item is serviced or replaced and the warranty time is less than 0.5 hours, ARB will accept a total warranty time of 0.5 hours. This will allow for assessment and administration of the warranty claim.

If multiple components are to be serviced or replaced under the same warranty claim, the full individual warranty time will not be paid to replace each component. The total warranty time paid will be calculated as follows:

Individual warranty time	→	<i>For component being replaced with the longest individual warranty time.</i>
+		
0.5 hours	→	<i>For each additional component being replaced with an individual warranty time greater than 0.5 hours</i>
+		
Individual warranty time	→	<i>For each additional component being replaced with an individual warranty time less than 0.5 hours</i>

4 SPARE PARTS

4.1 Spare parts list

The items in the following table correspond with the items on the exploded diagram in section [4.2](#).

ITEM	DESCRIPTION	QTY	ARB PART NUMBER
1	LID ELEMENTS	1	10910095
2	DECAL LID INST ELEMENTS	1	10910092
3	SEAL LID ELEMENTS	1	10910094
4	DRAIN KNOB INCL SEAL FOR ARB	1	10910075
5	TOUCH PAD ELEMENTS	1	10910091
6	COVER CONTROL ASSEMBLY	1	10910093
7	SEAL CONTROL PANEL ELEMENTS	1	10910089
8	CIRCUIT BOARD CONTROL PANEL ELEMENTS	1	10910090
9	CIRCUIT BOARD LIGHT ELEMENTS	1	10910088
10	LENS LIGHT ELEMENTS	1	10910087
11	VENT ELEMENTS	1	10910086
12	COMPRESSOR CONTROL UNIT	1	10910007
13	FAN S.S SCREW	4	10910059
14	RUBBER FOOT KIT ELEMENTS	1	10910085
15	HINGE KIT ELEMENTS	1	10910098
16	SCREW KIT HINGE ELEMENTS	7	10910099
17	BALL KIT GAS STRUT ELEMENTS	2	10910097
18	COMPRESSOR FEET ASSEMBLY INCL SHAFT	1	10910063
19	COVER COMPRESSOR CONTROL UNIT	1	10910106
20	BRUSHLESS FAN	1	10910009
21	BASKET ELEMENTS	1	10910108
22	DIVIDER BASKET ELEMENTS	1	10910107
23	COVER KIT CIRCUIT BOARD ELEMENTS	1	10910101
24	AC SOCKET PROTECTOR	1	10910020
25	PANEL REAR ELEMENTS	1	10910104
26	AC POWER SOCKET	1	10910018
27	DC POWER SOCKET	1	10910019
28	DECAL POWER ELEMENTS	1	10910103
29	SCREW KIT M6 CABINET	4	10910105
30	CIRCUIT BOARD MAIN ELEMENTS	1	10910102
31	RUBBER PLUG FOR TRANSMITTER	1	10910079
32	LOGO ARB ELEMENTS	1	10910096
33	GAS STRUT ELEMENTS	1	10910100
34	SCREW KIT M8 CABINET	6	10910109
35	COVER KIT LOCK	1	10910110
36	SOLENOID LOCK	1	10910112
37	LATCH KIT	1	10910115
38	LID STOPPER KIT	2	10910116
39	STRUT BRACKET KIT	1	10910117
40	COMPRESSOR BASE	1	10910111
41	PLASTIC CORNER KIT ELEMENTS	1	10910118

NOTES:

- Quantity column indicates maximum number of individual items per service repair.
- The part number given is for singular units unless otherwise stated in the item description.
- Drawings are indicative only, product appearance may change slightly.
- ~~123456~~ indicates "use to depletion" product, check stock with your ARB store.

4.2 Spare parts exploded drawing

The items in the following exploded diagram correspond with the items in the table in section [4.1](#).

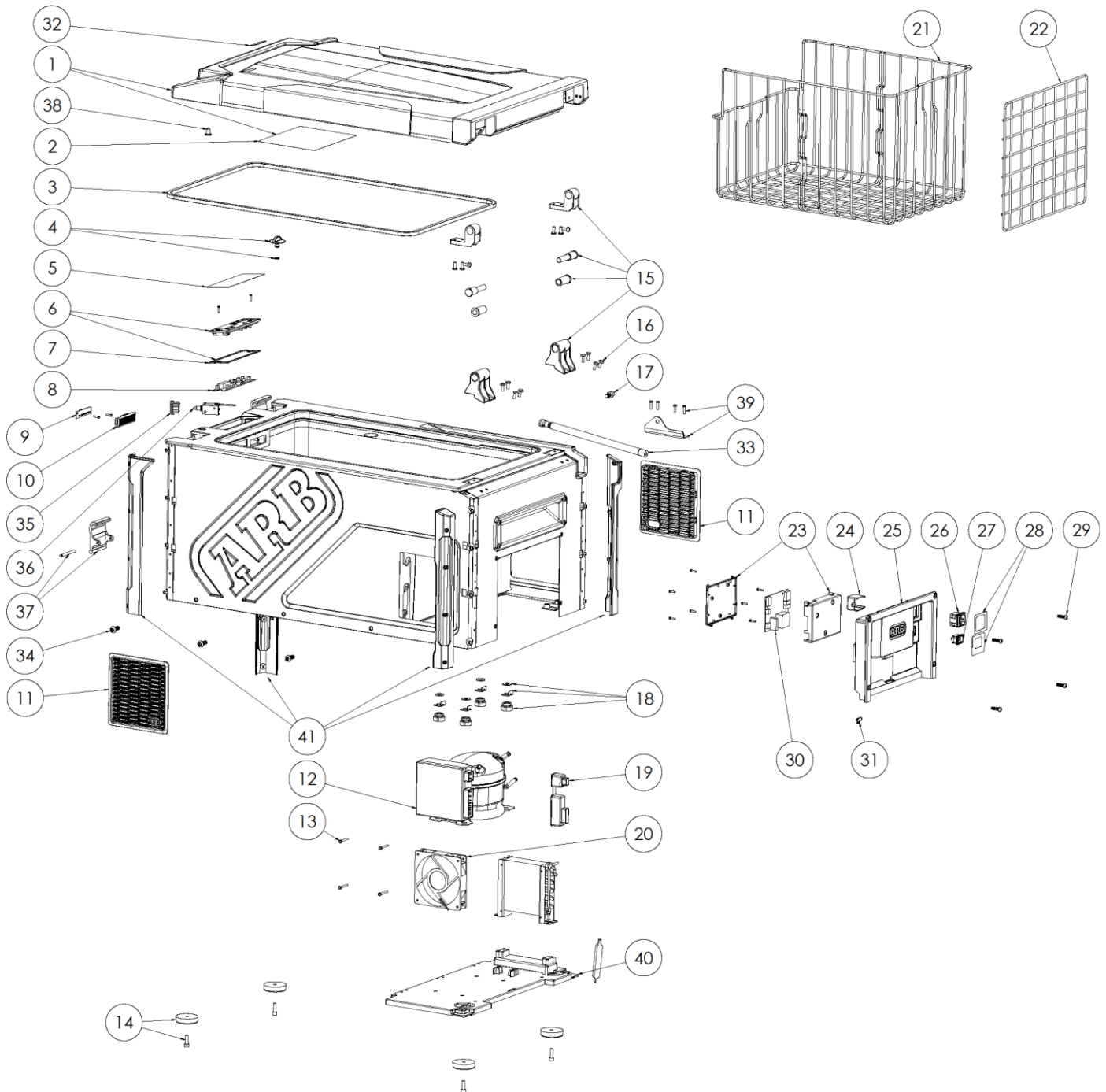

The following items are not illustrated in section [4.2](#).

DESCRIPTION	QTY	ARB PART NUMBER
Strap cable	1	10910114
Power Cord - DC	1	10910076
Power Cord AC, Plug I, Suit 10800xx1	1	10910011
Power Cord AC, Plug B, Suit 10800xx2	1	10910012
Power Cord AC, Plug F, Suit 10800xx3	1	10910013
Power Cord AC, Plug D, Suit 10800xx4	1	10910014
Power Cord AC, Plug G, Suit 10800xx5	1	10910015
Fuse AC 100-240V T2 4	1	10910033
Fuse DC Glass 12/24V 15Amp type 3AGA	1	
Control circuit board 5 pin cable	1	10910121
Cover power socket fridge (suits accessory outlet)	1	10910119
PCB wireless transmitter socket with lead	1	10910080
Thermistor	1	10910027

4.3 Minimum stocked spare parts

ARB recommends that the following parts be stocked by all ARB fridge freezer service agents. As these parts are consumed, they should be replaced as soon as possible to ensure that all items are on hand when required. For replacement parts, contact your regional ARB office.

Parts not listed in the table below can be ordered from ARB as required.

The item numbers in the table below correspond with the item numbers in the table in section [4.1](#) and the exploded drawing in section [4.2](#).

ITEM	DESCRIPTION	QTY	ARB PART NUMBER
12	COMPRESSOR CONTROL UNIT	1	10910007
20	BRUSHLESS FAN	1	10910009
8	CIRCUIT BOARD CONTROL PANEL ELEMENTS	1	10910090
6	TOUCH PAD CONTROL ELEMENTS	1	10910093
30	CIRCUIT BOARD MAIN ELEMENTS	1	10910102
	ARB DC POWER CORD	1	10910076
9	CIRCUIT BOARD LIGHT ELEMENTS	1	10910088
4	DRAIN KNOB INCL SEAL FOR ARB	1	10910075
21	BASKET ELEMENTS	1	10910108
22	DIVIDER BASKET ELEMENTS	1	10910107
	FUSE AC 100-240V T2 4AMP - F4L250V	1	10910033
	Fuse DC Glass 12/24V 15Amp type 3AGA	1	

NOTE: The touch pad (p/n 10910093) is required when servicing or replacing the control panel circuit board.

5 TOOLS REQUIRED

5.1 Basic servicing

The following tools will be required to perform general non-refrigeration based servicing of the fridge.

Basic tool kit

- Phillips head screw drivers (various sizes)
- Flat blade screw drivers (various sizes)
- Needle nosed pliers
- Wire (side) cutters
- Vice grips
- Sharp knife
- 5 mm hex key
- Cable ties
- 12V power supply
- Multimeter (with the following ranges)
 - DC voltage (0 - 24V)*
 - AC voltage (100 - 240V)*
 - Resistance (0.5 Ω – 50 k Ω)*
 - Temperature +10°C (+50°F) to -18°C (0°F)*
- Jumper cable
 - Short length of insulated wire terminated with spring loaded clips or push-on connectors at each end.*

The following tools will be required to perform specific non-refrigeration based servicing of the fridge

Check vehicle wiring (refer to section [8.1](#))

- DC Voltage Drop tester (available from ARB – part # 10910040)

Replacement of power sockets (refer to sections [9.11](#) and [9.12](#))

- Soldering iron & solder
- Heat shrink tubing (to suit 3 mm insulated wire) & heat gun

Replace serviceable thermistor (refer to section [9.17](#))

- Heat transfer paste (available from Jaycar p/n NM-2012)

5.2 Servicing the refrigeration system

It is expected that a refrigeration mechanic who is servicing the refrigeration system will have the appropriate equipment to pressure test, evacuate and charge the system with the specified refrigerant in accordance with local or State handling practices.

6 TROUBLESHOOTING

6.1 Check (diagnosis) lights

1 x flash every 4 seconds – **BATTERY PROTECTION CUT-OUT**

The battery protection system has turned the fridge freezer off because low voltage has been detected.

Things to check

- Check that the correct battery protection setting has been selected to suit the customer's requirements.
- Check the vehicle wiring is adequate.
 - For cable lengths up to 6m (20'), ARB recommends a minimum automotive cable size of 6 mm (4.5 mm²).
 - For cable lengths greater than 6m (20'), ARB recommends that you consult a qualified technician for advice on the correct wire size.
- Check that all terminals and joints are clean and in good condition.
- Check that the battery voltage at the socket is above the set cut-out voltage (refer to section [5.8](#)). To ensure that voltage drop is accounted for when measuring this voltage, refer to section [8.1](#).

NOTE: The battery protecting system only controls 12 and 24V DC supplies. To confirm that the fridge freezer is operating correctly, connect the fridge freezer to a standard 100-240V AC supply.

2 x flashes every 4 seconds – **FAN OVER-CURRENT CUT-OUT**

The control system has turned the fridge freezer off because the fan is drawing more than 0.5 amp while the compressor is running. This could be because the fan is running slowly or not running at all.

Things to check

- Check that the fan is not obstructed or dirty.

3 x flashes every 4 seconds – **MOTOR START ERROR**

The compressor will not start because the refrigerant system has become unbalanced. This can occur when the power to the fridge freezer is briefly interrupted.

Things to check

- Turn the fridge freezer off and disconnect it from its power supply.
- Allow the fridge freezer to stand for 10 to 15 minutes to allow the system to equalise.
- Reconnect the fridge freezer to the power supply and turn it on.
- Check that the fridge freezer is operating correctly.

4 x flashes every 4 seconds – **MINIMUM MOTOR SPEED ERROR**

The compressor motor is running below its minimum maintainable speed. This could be because the refrigerant system has been overcharged.

Consult a refrigeration mechanic to check that the system is charged with the correct amount of refrigerant.

5 x flashes every 4 seconds – **THERMAL CUT-OUT OF ELECTRONIC UNIT**

The fridge freezer has stopped operating because the control unit has become too hot.

Things to check

- Check to ensure that there is adequate ventilation around the control unit and the compressor.
- Check that the fan is operating correctly. The fan must always be running when the compressor is running.
- The fridge freezer may be operating in extremely high ambient temperatures. For example in a sealed stationary vehicle that is parked in the direct sunlight. Try to improve the ventilation around the fridge freezer or shield it from direct sunlight.

TROUBLESHOOTING

6.2 DC Power Supply

Symptom	Possible Cause(s)	Suggested Action(s)
Fridge does not run when using a 12/24V DC power supply.	12/24V DC plug fuse has blown.	Replace 12/24V DC plug fuse (refer to section 8.8). The correct rating is T8 Amp 32V.
	Fault with 12/24V DC fridge power lead.	Check continuity of lead from plug to socket. Replace lead if faulty or damaged.
	Poor connection of plug to socket in back of fridge.	Check that plug is correctly installed into socket in back of fridge. NOTE: A poor connection can cause high resistance and a large voltage drop. This can cause the battery protection system to activate prematurely.
	No power to supply socket from power source (eg vehicle battery).	Check that vehicle wiring is correct and that power is available at the outlet socket.
	The DC supply voltage is below the minimum voltage needed to operate the fridge.	Connect the fridge to a 12 or 24V DC power supply. Check the supply voltage. NOTE: The compressor control unit and digital display will not operate if the supply voltage is below approximately 7V DC.
	The polarity of the fridge power circuit is wired incorrectly. This means the positive (+) and negative (-) wires are connected back to front.	Check the DC wiring circuit to ensure the polarity (“+” and “-”) is correct. NOTE: The compressor control unit has inbuilt polarity protection and will not function if the polarity is incorrect.
	Poor electrical connection inside the fridge between the power socket and the compressor control unit.	Check connections between the DC socket and the “+” and “-” terminals on the compressor control unit.
		Check that approximately 12 or 24V DC is measured at the “+” and “-” terminals.

TROUBLESHOOTING

DC Power Supply (continued)

<i>Symptom</i>	<i>Possible Cause(s)</i>	<i>Suggested Action(s)</i>
Fridge does not run when using a 12/24V DC power supply.	Power LED is orange. Fridge has reached cabinet temperature and is functioning correctly.	Reduce target cabinet temperature. Power LED will change to green, compressor will start and fridge will start cooling.
	Faulty compressor control unit.	Test compressor control unit (refer to section 8.2). If compressor does not run during test, replace control unit (refer to section 9.4) and repeat test. If compressor still fails to run, test compressor (refer to section 8.5).
	Faulty control panel circuit board.	Test compressor control unit (refer to section 8.2). If control unit is ok, test fridge with new control panel circuit board and replace if necessary (refer to section 9.1).
	Faulty main circuit board.	Test compressor control unit (refer to section 8.2). If control unit is ok, test fridge with new main circuit board and replace if necessary (refer to section 9.5).
	Faulty thermistor.	Test compressor control unit (refer to section 8.2). If control unit is ok, test fridge with new thermistor and replace if necessary (refer to section 9.17).
	Fault within main wiring loom.	Test continuity of wiring loom from main circuit board to control panel circuit board. If fault identified and unrepairable, contact ARB for advice.
	Faulty compressor.	Test compressor (refer to section 8.5). If compressor is faulty, contact a licensed refrigeration mechanic for assistance. NOTE: A faulty compressor is extremely unlikely.
Interior light does not work.	Faulty LED lamp assembly.	Replace interior light (refer to section 9.8).
Fridge will not run when DC input voltage exceeds 13.8V (eg When vehicle is running)	Faulty main circuit board.	Replace main circuit board (refer to section 9.5) and retest.



TROUBLESHOOTING

DC Power Supply (continued)

<i>Symptom</i>	<i>Possible Cause(s)</i>	<i>Suggested Action(s)</i>
12/24V DC fridge lead plug fuse blows repeatedly.	Fault within 12/24V DC fridge power lead.	Check continuity of lead from plug to socket. Replace lead if faulty or damaged.
	Incorrect fuse used in plug.	Install the correctly rated fuse. The correct rating is T8 Amp 32V (refer section 9.9).
	Short circuit between “+” and “-” terminals on compressor control unit.	Check for short circuits between the “+” and “-” terminals on the compressor control unit.
Compressor stops running, LED display is visible, error light flashes once every 5 seconds.	Compressor has stopped running because battery cut-out voltage has been reached.	Check that correct battery protection setting is selected (refer section 6.6).
		Check that vehicle wiring is adequate. Refer to section 8.1 .
		Check battery voltage and voltage at supply socket. NOTE: Voltage readings must be taken with a load on the circuit to allow for voltage drop within the circuit (refer to section 8.1).
		Check that plug is correctly installed into socket in back of fridge.
		Check that plug is correctly installed into supply socket in vehicle.
		Test fridge on 100-240V AC to confirm correct operation of fridge.
Intermittent power supply to fridge.	Poor connection of plug into socket in back of fridge.	Check that plug is correctly installed into socket in back of fridge.
		Check that the plug makes firm connection with the terminals inside the fridge socket. If fit is loose, test fridge with new power lead. If symptom resolved, replace power lead.
	Poor connection of plug into supply socket (eg vehicle accessories socket).	Check that plug is correctly installed into the supply socket.
	Compressor has stopped running because battery cut-out voltage has been reached.	Check that correct battery protection setting is selected (refer section 6.6).
Check that vehicle wiring is adequate. Refer to section 8.1 .		

TROUBLESHOOTING

DC Power Supply (continued)

<i>Symptom</i>	<i>Possible Cause(s)</i>	<i>Suggested Action(s)</i>
Fridge runs but digital display is not visible.	Faulty control panel circuit board.	Test with new control panel circuit board (refer to section 9.1). If symptom resolved, replace circuit board.
Fridge runs but cannot change target temperature.	Faulty control panel circuit board.	Test with new control panel circuit board (refer to section 9.1). If symptom resolved, replace circuit board.
Fridge does not run, error light flashes twice every 5 seconds	The fan is not connected to the compressor control unit.	Check the fan wiring to ensure the “+ve” and “-ve” fan wires are correctly connected to the compressor control unit (refer section 9.4).
	Faulty fan.	Test with new cooling fan (refer to section 9.7). If symptom resolved, replace fan. NOTE: The fan must be running whenever the compressor is running.
	Faulty compressor control unit.	Test compressor control unit (refer to section 8.2). If symptom resolved, replace control unit (refer to section 9.4).
Interior cabinet light does not work.	Interior LED is faulty.	Replace LED (refer to section 9.8).
	No power to fridge.	Check that either 12/24V DC or 100-240V AC power is being supplied to the fridge.
	Faulty main circuit board	Test operation of light with new main circuit board. If symptom resolved, replace circuit board.
	Faulty light switch	Replace cabinet assembly.
Digital display shows “Err1” 	The thermistor is not correctly connected to the control panel circuit board.	Check connection of thermistor to control panel circuit board.
	Thermistor circuit is ‘open circuit’.	Test thermistor (refer to section 8.6) and replace if necessary.
Digital display shows “Err2” 	Thermistor circuit is ‘short circuit’	Test thermistor (refer to section 8.6) and replace if necessary.
Digital display shows “Err3” 	Faulty control panel circuit board.	Replace control panel circuit board (refer to section 9.1).

TROUBLESHOOTING

6.3 AC Power Supply

<i>Symptom</i>	<i>Possible Cause(s)</i>	<i>Suggested Action(s)</i>
No power to fridge when using a 100-240V AC power supply.	Poor connection of plug to back of fridge.	Check that plug is correctly installed into the socket in back of fridge.
	Device fuse in back of fridge cabinet has blown.	Replace device fuse. Refer to section 9.10 .
	No power to supply socket from AC power source.	Check that there is power to the supply socket from the AC power source. NOTE: If using a poor quality power generator, it is possible that the supply voltage could be above or below the 100-240V AC power range and may not be a pure, non-fluctuating sine wave.
	Poor electrical connection inside the fridge between the AC power socket and the compressor control unit.	Check AC electrical wiring within the fridge. NOTE: All AC electrical work should be carried out by a qualified electrician.
	Faulty main circuit board.	Test main circuit board (refer to section 8.3) and replace if necessary.
		Test with new main circuit board. If symptom resolved, replace circuit board (refer to section 9.5).
Faulty compressor control unit.	Test compressor control unit on AC power (refer section 8.4). Replace if necessary.	
	Test with new compressor control unit. If symptom resolved, replace control unit (refer to section 9.4).	
Device fuse repeatedly blows.	Short circuit in 100-240V AC fridge cable.	Check continuity of lead from plug to socket. Replace lead if faulty or damaged.
	Short circuit between terminals "L" and "N" on compressor control unit.	Check for short circuit between the "L" and "N" terminals on the compressor control unit.
	Unregulated and/or fluctuating power supply. For example <i>From an engine driven generator.</i>	Ensure that the generator has a voltage regulator and is supplying a standard, pure sine wave AC voltage without fluctuation in voltage or frequency NOTE: Ensure that the fridge is turned off before starting or stopping the generator.
	Fault with compressor control unit.	Test with new compressor control unit & replace if necessary (refer section 9.4).

TROUBLESHOOTING

6.4 Cooling

Symptom	Possible Cause(s)	Suggested Action(s)
Fridge does not cool. Compressor runs.	Poor ventilation.	Check that there is sufficient clearance around the fridge and that the fan is not obstructed.
	Compressor starts and stops because the battery protection system is active. Error light flashes once every 5 seconds.	Check that the correct battery protection setting is selected (refer section 6.6).
		Check that vehicle wiring is adequate (refer to section 8.1).
	NOTE: In the rear of a vehicle, the customer may be unaware that this is occurring.	
	The lid seal is damaged or missing.	Check seal is installed correctly into lid and it is in good condition. Replace seal if damaged or missing (refer section 9.16).
	Leak in refrigerant system.	Look for visible oil leaks around the refrigeration lines, compressor and condenser. If a leak is detected, contact a qualified refrigeration mechanic for service advice.
If no leak detected, contact a qualified refrigeration mechanic and request that the system is pressure tested.		
Blockage within the refrigeration system.	Contact a qualified refrigeration mechanic for service advice.	
Fridge does not cool. Compressor does not run.	Faulty compressor control unit.	Test compressor control unit (refer to section 8.2) and replace if necessary (refer to section 9.4).
	Faulty control panel circuit board.	Test compressor control unit (refer to section 8.2). If control unit ok, test fridge with new control panel circuit board and replace if necessary (refer section 9.1).
	Faulty main circuit board.	Test compressor control unit (refer to section 8.2). If control unit is ok, test with new main circuit board and replace if necessary (refer to section 9.5).
	Faulty thermistor.	Test compressor control unit (refer to section 8.2). If control unit is ok, test with new thermistor and replace if necessary (refer to section 9.17).
	Faulty compressor. NOTE: A faulty compressor is extremely unlikely.	Test compressor (refer to section 8.5). If compressor is faulty, contact a licensed refrigeration mechanic for assistance.

TROUBLESHOOTING

Cooling (continued)

Symptom	Possible Cause(s)	Suggested Action(s)
Temperature display is not accurate with cabinet temperature.	Time lag has not been allowed for.	Allow the fridge to reach the set temperature and cycle a few times before assessing accuracy of temperature. NOTE: A display temperature within 2-3°C (3.6-5.4°F) of the actual temperature at the base of the fridge is within normal on/off cycle temperature variation.
	Frozen items have been placed directly on top of thermistor.	Rearrange items in fridge so that frozen items are not located directly on top of the thermistor. NOTE: The thermistor is located in the base of the fridge directly under the centre of the plastic liner.
	Internal temperature correlation settings inaccurate.	Adjust the internal temperature correlation setting (refer to section 8.7). NOTE: This should not be necessary unless the thermistor has been replaced.
Items freeze with fridge set to warmest setting.	Faulty thermistor.	Test thermistor (refer to section 8.6) and replace if necessary (refer section 9.17).
	Faulty control panel circuit board.	Test fridge with new control panel circuit board and replace if necessary (refer to section 9.1).
	Faulty main circuit board	Test fridge with new main circuit board and replace if necessary (refer to section 9.5).
Fridge does not reach target temperature.	Fridge is operating at its maximum cooling capacity in extreme ambient temperatures.	The maximum cooling capability of the system is a reduction of 50°C (122°F) below ambient temperature. For example <i>In ambient temperatures above 32°C (73°F), the system may not cool to a cabinet temperature of -18°C (0°F).</i>
Large temperature difference between the top and bottom of fridge.	The temperature within the cabinet will vary as the compressor cycles on and off. The temperature difference will vary depending on factors like how the fridge is loaded and how often it is opened.	Advise the customer that some temperature variation is normal within the fridge. NOTE: The temperature difference can increase as the cabinet temperature decreases.

TROUBLESHOOTING

Cooling (continued)

Symptom	Possible Cause(s)	Suggested Action(s)
Fridge cools but compressor runs continuously.	Poor ventilation.	Check that there is sufficient clearance around the fridge and that the fan is not obstructed.
	Fridge is operating at or near the thermal capacity of system.	The thermal capacity of the system is 50°C (122°F) below ambient temperature.
	The lid seal is damaged or missing.	Check that the seal is installed correctly into the lid and that it is in good condition. Replace the seal if it is damaged or missing (refer section 9.16).
	Faulty thermistor.	Test thermistor (refer to section 8.6) and replace if necessary (refer section 9.17).
	Faulty control panel circuit board.	Test fridge with new control panel circuit board and replace if necessary (refer to section 9.1).
	Faulty main circuit board.	Test fridge with new main circuit board and replace if necessary (refer to section 9.5)
	Insufficient charge of refrigerant in compressor system.	Contact a qualified refrigeration mechanic and request that the system is pressure tested.
	Partial blockage within the refrigeration system.	Contact a qualified refrigeration mechanic for service advice.
Noisy compressor	Compressor is loose or not correctly mounted.	Inspect the compressor to ensure that it is correctly mounted. Replace compressor mounting feet if necessary (refer to section 9.14).
	Noise from inside compressor when fridge experiences high movement and/or vibration.	This noise is normal when the fridge experiences high movement and/or vibration. <i>The Danfoss compressor is built to military specifications and has inbuilt limit stops to prevent damage. Under high movement or vibration, these bump stops are designed to contact the compressor housing to prevent internal damage to the compressor.</i>
	System is low on refrigerant.	Perform checks listed above under “Fridge does not cool. Compressor Runs”.
Digital display shows temperature values in the wrong units.	The internal settings within the control panel are incorrect.	Refer to the owner’s manual for directions on changing temperature units between °C and °F.

TROUBLESHOOTING

6.5 General

Symptom	Possible Cause(s)	Suggested Action(s)
Lid is hard to release from body of fridge.	The hinge assembly has become contaminated with dirt.	Carefully remove the lid from the body of the fridge. Remove any dirt or grit from the hinge sockets and service the hinge assembly (refer to sections 9.18). HINT: Use a thin piece of steel or plastic (eg a 150 mm ruler) to help disengage the hinge pins.
	Gas strut faulty or contaminated with dirt.	Remove and inspect gas strut. If cannot free the strut, replace with new as per section 9.24).
Latch does not easily disengage from lid.	The high quality seal is causing the lid to sit away from the fridge cabinet.	Press down on the lid slightly to help disengage the latch from the lid.
Noisy fan.	Obstruction in fan.	Remove foreign material from the fan and retest system.
	Faulty fan.	Remove fan from fridge and test. If fan is identified as faulty, replace with new fan (refer to section 9.7).
Lid opens during transit.	The latch was not closed correctly.	Advise customer that latch must be correctly closed before transportation.
	Faulty latch.	Inspect latch and latch pivot for damage.
Lid will not open when fridge is running.	The air inside the fridge has cooled forming a negative pressure within the cabinet.	Remove the drain plug to allow the pressure inside the cabinet to equalise with the ambient air.
	This can occur when the fridge is left running while empty.	Advise customer to remove drain plug from drain if the fridge is to be left running with nothing inside it. HINT: Dislodge the drain plug from the fridge cabinet by pushing it up from under the fridge use a small round rod or similar.
Hinge noisy during operation.	The hinge sockets have become dirty.	Remove lid from body of fridge. Clean hinge sockets. Refer to section 9.18).



TROUBLESHOOTING

6.6 Battery Protection Settings

The ARB Fridge Freezer is fitted with a battery monitor to control the level of discharge of the supply battery. The battery monitor has three settings; HIGH, MEDIUM and LOW. When set to HIGH, the battery monitor will provide maximum protection for the battery against excessive discharging. When set to LOW, the battery monitor will allow maximum use of the energy stored in the battery. The table below shows the voltage cutout levels for the three battery monitor settings.

	BATTERY MONITOR MODE		
	LOW	MED	HIGH
Switch off voltage – 12V DC	10.1V	11.4V	11.8V
Restart voltage – 12V DC	11.1V	12.2V	12.6V
Switch off voltage – 24V DC	21.5V	24.1V	24.6V
Restart voltage – 24V DC	23.0V	25.3V	26.2V

To change the battery protection level:

- Turn the fridge freezer on.
- Press  three times to display current battery protection setting.
- Press  or  to change the battery protection voltage between High (HI), Medium (nEd) and Low (Lo).
- After 5 to 6 seconds of inactivity, the display will flash twice and return to displaying the current cabinet temperature.



NOTE: The battery protecting system only controls 12 and 24V DC supplies. To confirm that the fridge freezer is operating correctly, connect the fridge freezer to a standard 100-240V AC supply.

7 FAULT FINDING FLOW CHARTS

7.1 Fridge will not run on 100-240V AC power

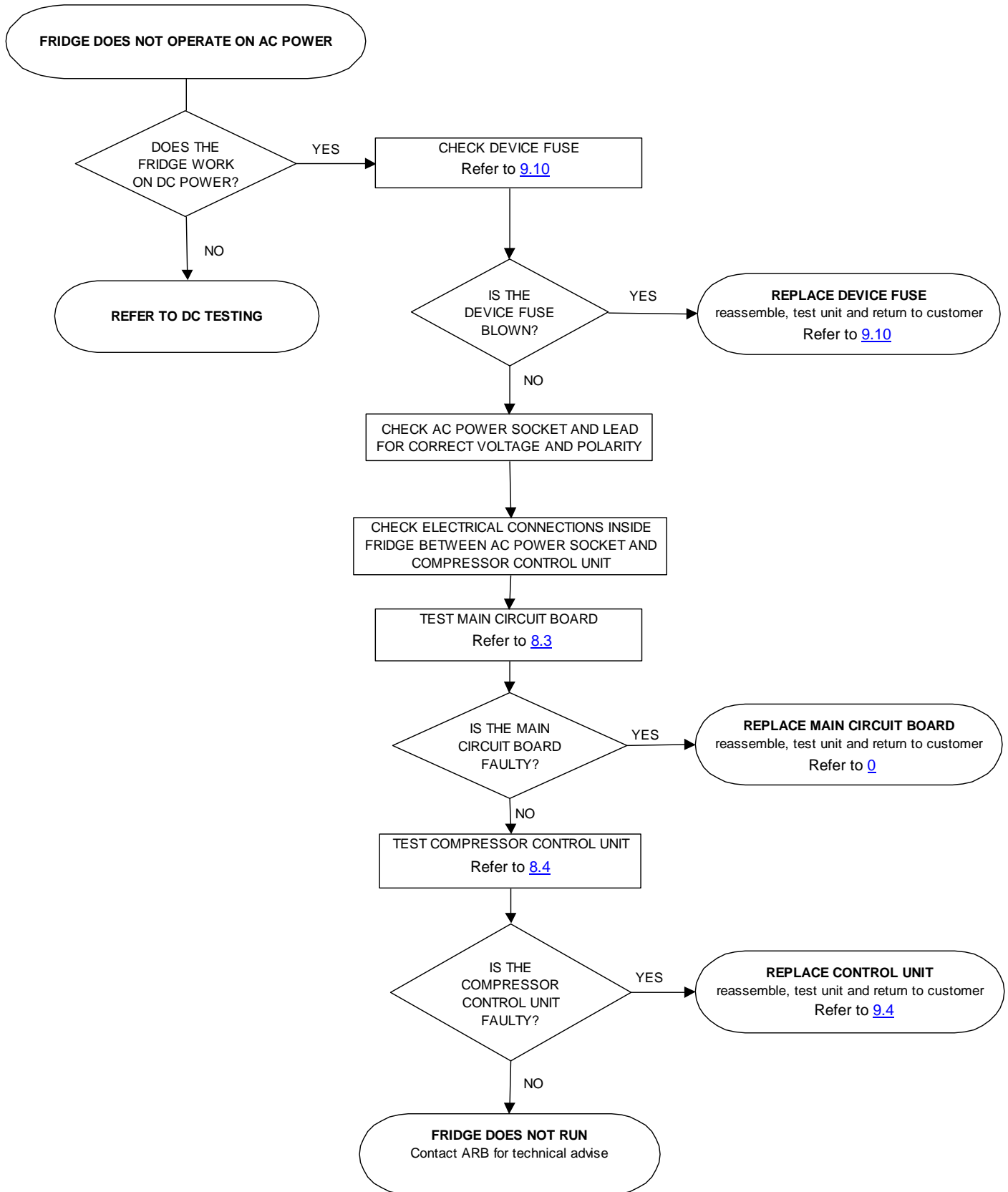

7.2 Fridge will not run on 12/24V DC power

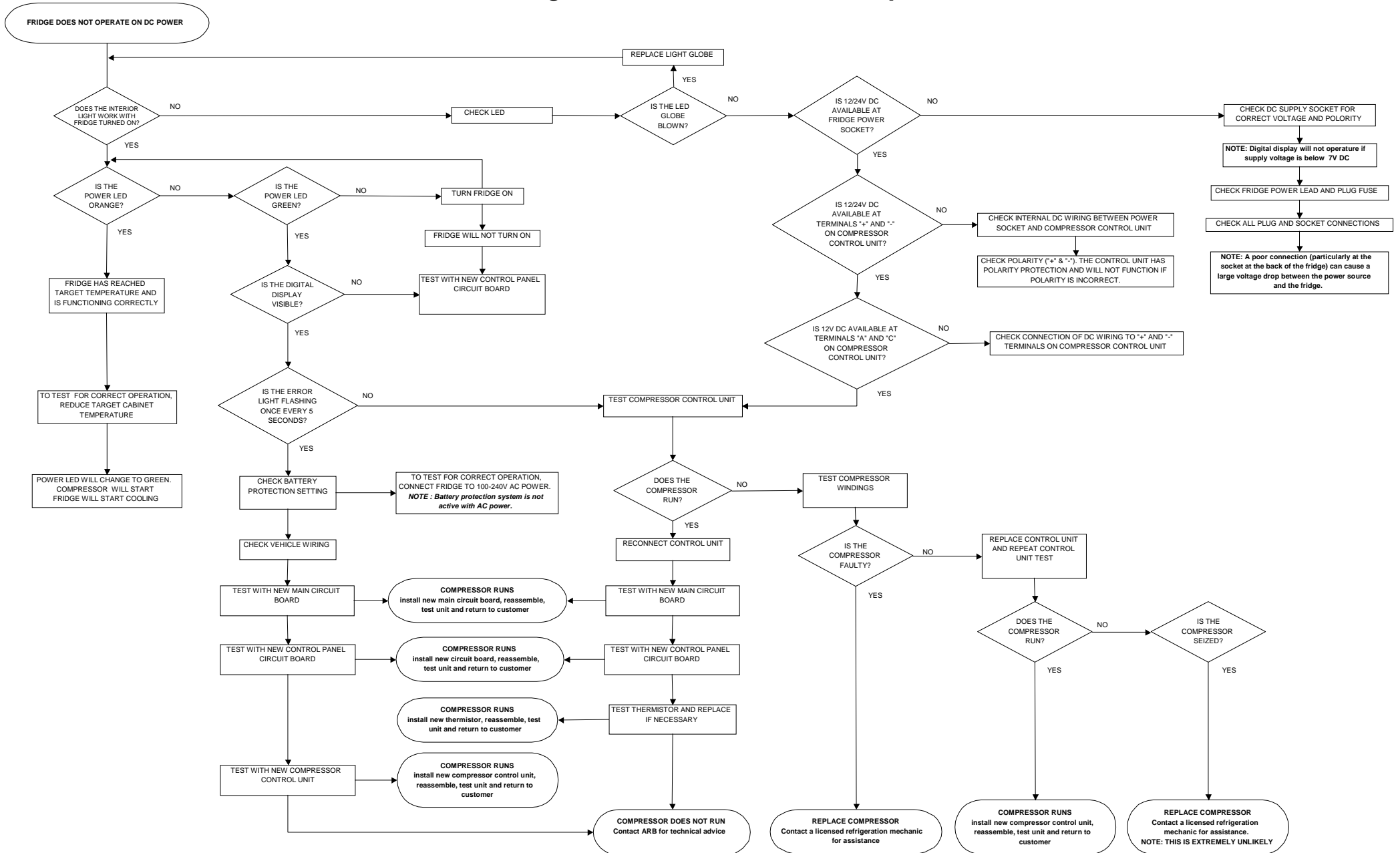

8 CHECKS AND TESTS

8.1 Vehicle wiring system

It is important that the wiring system is capable of carrying the required load to power the fridge freezer. The accessories wiring system in many vehicles is not adequate for such a task. This is particularly true in the rear cargo space of many modern four wheel drives. In some vehicles, these circuits are also connected to the ignition switch and will not supply power if the ignition is turned off.

Measuring the voltage across the battery will not give a true indication of the voltage being supplied to the fridge. Any voltage readings must be taken at the fridge supply socket with the fridge running. This is because any voltage drop caused by losses in the system must be accounted for. Without the fridge running, there will be no load on the circuit and it will not be possible to measure the voltage drop.

Voltage drop is the difference between the voltage readings taken at the fridge supply socket with and without the fridge running. It is calculated using the formula shown below.

$$\begin{array}{l} \text{Voltage drop between} \\ \text{battery and supply} \\ \text{socket} \end{array} = \begin{array}{l} \text{Voltage reading at} \\ \text{supply socket without} \\ \text{fridge running} \end{array} - \begin{array}{l} \text{Voltage reading at supply} \\ \text{socket with fridge running} \end{array}$$

NOTE: In some 12V vehicle wiring systems, the voltage drop between the battery and the rear factory accessories socket can exceed 2V DC.

It is important that the vehicle is not running while these voltage readings are taken. If the vehicle is running, the readings will be the supply voltage from the alternator and not the voltage from the battery.

To check the vehicle wiring system, ARB recommend using a voltage drop tester. The voltage drop tester will simulate the start-up conditions of the Danfoss Compressor. These voltage drop testers are available from ARB and have been specifically built to simulate the running of an ARB Fridge Freezer (all models).

The procedure for testing a vehicle wiring system using a voltage drop tester is given below. Suggested actions based on the results of the voltage drop test are given at the end of this procedure.

VOLTAGE DROP TEST

Purpose: To test the vehicle wiring system for voltage drop under a simulated fridge freezer load.

Procedure: See below

	<p>Turn off the vehicle's engine.</p> <p>Turn off the vehicle's ignition.</p> <p>Insert the plug from the voltage drop tester into the fridge/accessories supply socket.</p>
---	--

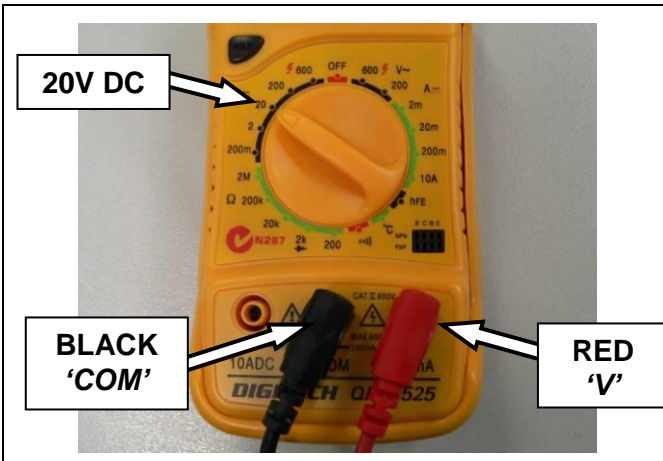

Connect the red lead from the voltage drop tester to the volt ('V') socket on the multimeter.

Connect the black lead from the voltage drop tester to the 'COM' socket on the multimeter.

Set the multimeter to 20V DC.



Record the voltage displayed on the multimeter as '**VOLTAGE A**'.

If no voltage is measured, check whether the circuit is connected to the ignition switch and whether the ignition is turned off.

NOTE: ARB recommend that a dedicated wiring circuit be used to connect the fridge directly to the battery via a suitable fuse. Refer to the wiring advice below.



Press the red button on the voltage drop tester and hold for no longer than 10 seconds.

This will simulate the start-up of the Danfoss compressor.

With the button pressed down, record the voltage displayed on the multimeter as '**VOLTAGE B**'.



Turn off the multimeter and disconnect the voltage drop tester from the power socket.

Record the voltage across the supply battery terminals as '**VOLTAGE C**'.

Calculate the voltage drop by using the formula below.

$$\text{VOLTAGE DROP} = \text{VOLTAGE 'A'} - \text{VOLTAGE 'B'}$$

If the voltage drop is greater than 0.5 V in a 12V DC system, significant voltage drop is present within the circuit while the fridge is running.

TEST OUTCOMES – VOLTAGE DROP TEST

1. Voltage drop detected

If a significant voltage drop (greater than 0.5 volts for a 12V DC system) is detected, the following checks should be undertaken.

A. Check the size of the wiring used in the circuit.

A dedicated wiring circuit should be installed to power the fridge freezer. This circuit should be as short as practical and should be connected directly to the power supply via a suitable fuse.

- Use a 15 Amp fuse for 12V DC applications and a 7 Amp fuse for 24V DC applications.
- For cable lengths up to 6m (20'), use a minimum automotive cable size of 6 mm (approx 4.5 mm²).
- For cable lengths greater than 6m (20'), consult a qualified auto electrician for advice on the correct wire size.
- For best performance, the negative wire of the circuit should be connected directly to the negative terminal of the battery. It should not be grounded directly to the vehicle body or chassis.

B. Check that all terminals and joints are clean and in good condition.

C. Check that the voltage at the supply socket (*VOLTAGE B*) is above the cut-out voltage for the selected battery protection setting (refer to section [6.6](#)).

D. Check that the supply socket is not attached to the vehicle ignition switch. If it is, make sure that the ignition switch is not turned off.

2. Measured voltage below cut-out voltage

If the voltage measured at the supply socket (*VOLTAGE B*) is below the cut-out voltage for the current battery protection setting (refer to section [6.6](#)), the compressor will not run and the error light will flash once every 5 seconds. In this case, the correct battery protection setting should be selected or the supply cable upgraded to 4.5mm² to minimise voltage drop

3. Low voltage detected at both battery and supply socket

If low voltage is detected at both the battery (*VOLTAGE C*) and the supply socket (*VOLTAGE B*), it is recommended that the battery be charged or replaced.

8.2 Test compressor control unit – 12/24V DC



Purpose: To verify the correct operation of the compressor control unit on 12/24V DC.

Approach: This test will isolate the compressor control unit from the external control circuit. The external control circuit includes the main circuit board, the control panel circuit board, the thermistor and the wiring loom.

Test pass: The compressor runs. In this case the main circuit board, the control panel circuit board, the thermistor or the wiring loom are likely to be faulty.

Test fail: The compressor does not run. In this case the compressor control unit is likely to be faulty. It is also possible that the compressor could be faulty but this is EXTREMELY unlikely.

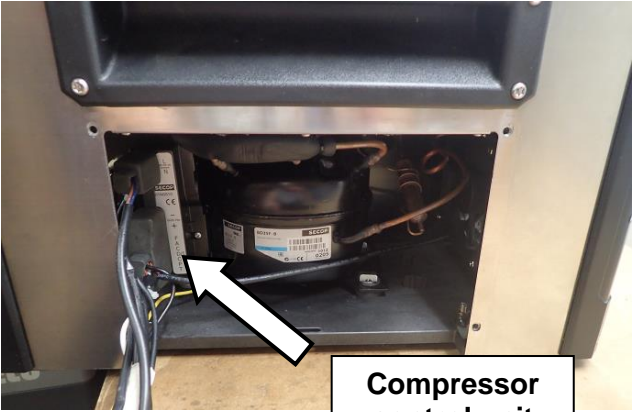
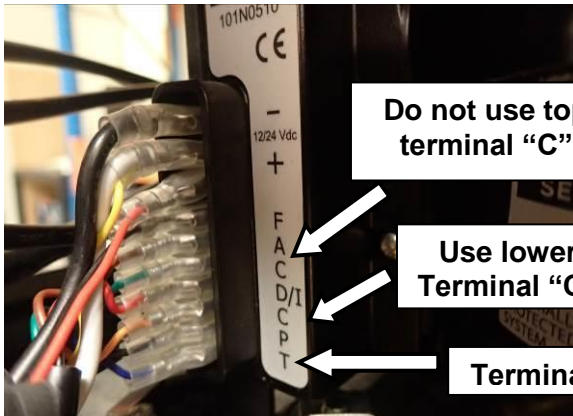
Procedure: See below

 <p style="text-align: center;">Compressor control unit</p>	<p>Disconnect all power leads from the back of the fridge.</p> <p>Remove the rear cover (refer to section 9.3).</p> <p>Identify the compressor control unit.</p>
 <p style="text-align: center;">Do not use top terminal "C"</p> <p style="text-align: center;">Use lower Terminal "C"</p> <p style="text-align: center;">Terminal "T"</p>	<p>Disconnect the push on connectors from terminal "T" and the lower terminal "C".</p> <p>NOTE: There are 2 terminals on the control unit that are labelled "C". Only disconnect the plug from the lower "C" terminal.</p>
 <p style="text-align: center;">Connection to 12/24V DC</p>	<p>Apply 12 or 24V DC to terminals "+" and "-" on the compressor control unit.</p> <p>Use a DC voltmeter to confirm that the polarity of the 12 or 24V DC supply voltage across terminals "+" and "-" is correct.</p> <p>NOTE: The compressor control unit has polarity protection and will not work if the polarity is incorrect.</p> <p>NOTE: The compressor control unit and digital display will not operate if the supply voltage is below approximately 7V DC.</p> <p>ARB recommends that the supply voltage be applied through the DC power socket in the back of the fridge and not directly to the control unit.</p>

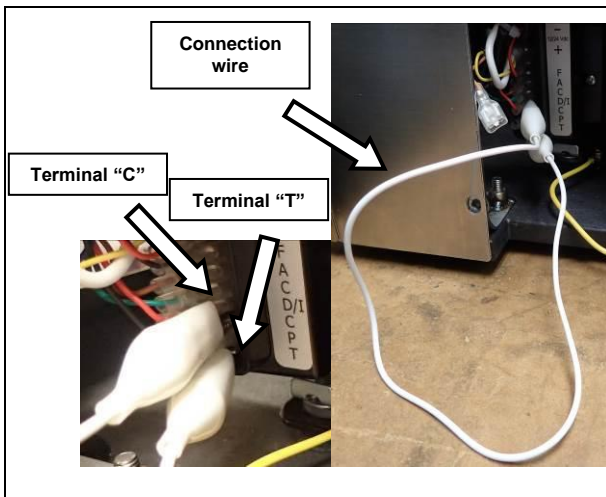

Connect between terminals “T” and the lower terminal “C” using a short length of wire as shown.

NOTE: *The connecting wire should be terminated with either push-on connectors or spring loaded clips suitable for connection to the terminals.*

CAUTION: *Make sure that there are no short circuits between the terminals and the connecting wire.*

TEST PASS – COMPRESSOR RUNS

With terminals “T” and lower “C” connected, the compressor should start running and the system should start cooling. In this case, the control unit is functioning correctly on 12/24V DC.

The compressor control unit has now been eliminated as a possible fault.

The next step is to investigate a fault in the main circuit board, the control panel circuit board, the thermistor or the wiring loom.

Before continuing, disconnect the fridge from the 12/24V DC power supply, remove the connecting wire and refit the push on connectors to terminals “T” and lower “C”.

NOTE: *During this test, the compressor should draw approximately 3 amps.*

NOTE: *There may be a delay of up to 5 seconds between connection of terminals “T” & lower “C” and the compressor starting.*

TEST FAIL – COMPRESSOR DOES NOT RUN

With terminals “T” and lower “C” connected, the compressor does not start. In this case, either the compressor or the compressor control unit are likely to be faulty.

Test the compressor windings (refer to section [8.5](#)).

If the compressor windings are OK, replace the control unit (refer to section [9.4](#)) and repeat the compressor control unit test.

If the compressor does not run with a new compressor control unit, the compressor may be seized. While it is possible for the compressor to be seized, it is EXTREMELY unlikely.

8.3 Test main circuit board – 100-240V AC

WARNING: This test should only be performed by a licensed electrician.

Purpose: To verify that the AC power section of the main circuit board is functioning correctly.

Procedure: See below.

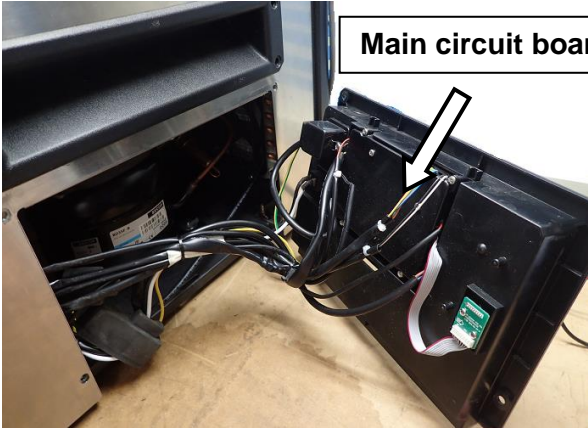
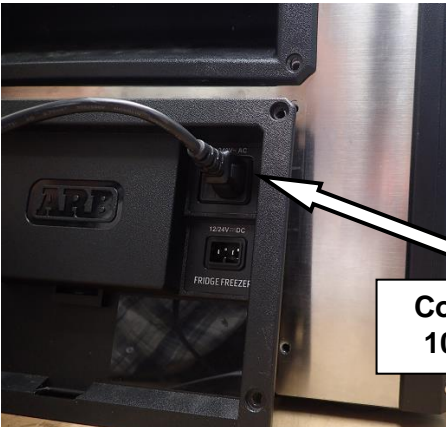
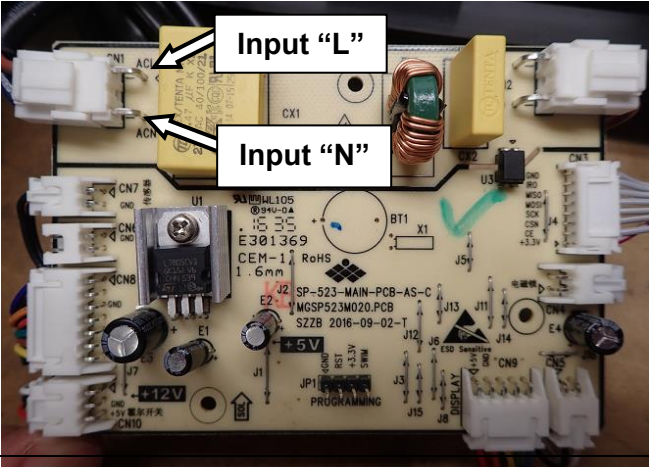
 <p data-bbox="496 421 780 465">Main circuit board</p>	<p data-bbox="794 412 1422 479">Disconnect all power leads from the back of the fridge.</p> <p data-bbox="794 510 1430 544">Remove main circuit board (refer to section 9.5).</p>
 <p data-bbox="491 1178 764 1267">Connection to 100-240V AC</p>	<p data-bbox="794 898 1406 965">Apply 100-240V AC power to the fridge via the power socket in the back of the fridge.</p>
 <p data-bbox="347 1413 480 1447">Input "L"</p> <p data-bbox="347 1525 480 1559">Input "N"</p>	<p data-bbox="794 1391 1445 1514">Using an AC voltmeter, check that 100-240V AC power is measured between the live "L" and neutral "N" terminals on the input side of the main circuit board as shown.</p> <p data-bbox="794 1559 1445 1626">If no AC power is detected, check the device fuse and the AC power supply.</p>

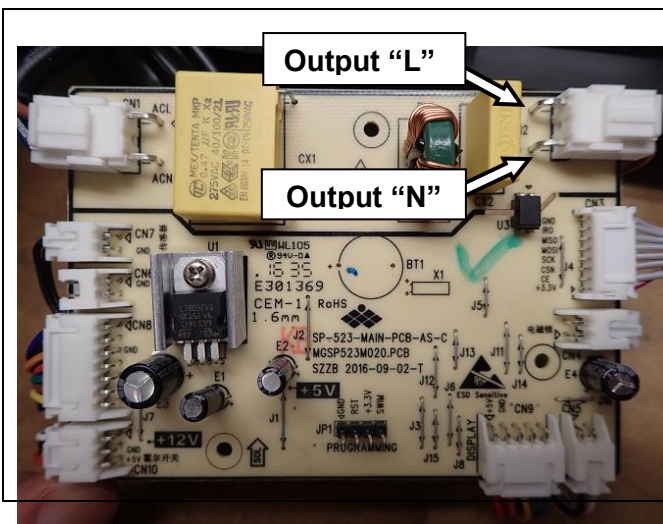

Using an AC voltmeter, check that the same AC voltage is measured between the live “L” and neutral “N” terminals on the output side of the main circuit board as shown.

TEST PASS – AC POWER IS MEASURED ON BOTH SIDES OF THE MAIN CIRCUIT BOARD

The same AC power measurement is recorded across both the input and output pins of the main circuit board. In this case, the AC power section of the main circuit board is functioning correctly.

The main circuit board has now been eliminated as a possible fault.

**TEST FAIL
AC POWER IS ONLY MEASURED ON THE INPUT SIDE OF THE MAIN CIRCUIT BOARD**

AC power is measured across the input pins of the main circuit board but not across the output pins. In this case, it is likely that the main circuit board is faulty.

The main circuit board should be replaced and the test repeated (refer to section [9.5](#)).

8.4 Test compressor control unit – 100-240V AC

WARNING: This test should only be performed by a licensed electrician.

Purpose: To verify the correct operation of the AC power section of the compressor control unit.

Procedure: See below.

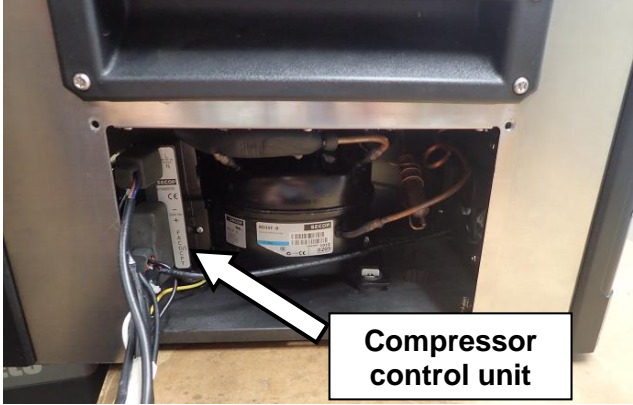
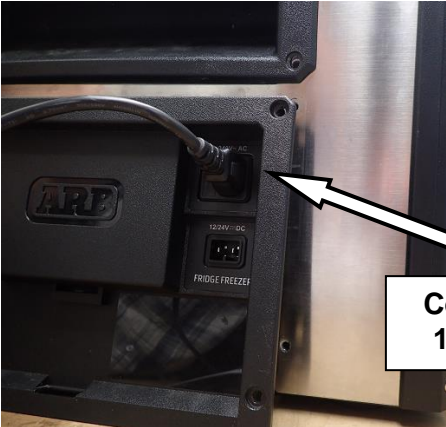
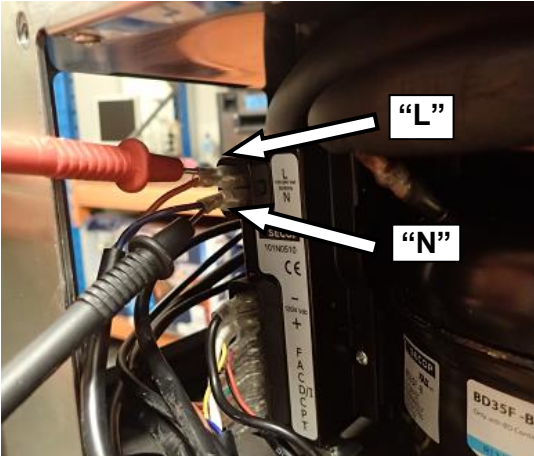
 <p>Compressor control unit</p>	<p>Disconnect all power leads from the back of the fridge.</p> <p>Remove the rear cover (refer to section 9.3).</p> <p>Identify the compressor control unit.</p>
 <p>Connection to 100-240V AC</p>	<p>Apply 100-240V AC power to the fridge via the power socket in the back of the fridge.</p>
 <p>“L”</p> <p>“N”</p>	<p>Using an AC voltmeter, check that 100-240V AC power is measured between the live “L” and neutral “N” terminals on the compressor control unit.</p> <p>If no AC power is detected between terminals “L” and “N” check the device fuse, the AC power supply and the main circuit board (refer to section 8.3).</p> <p>NOTE: There may be small variation above or below 100-240V AC depending on the AC supply voltage.</p>

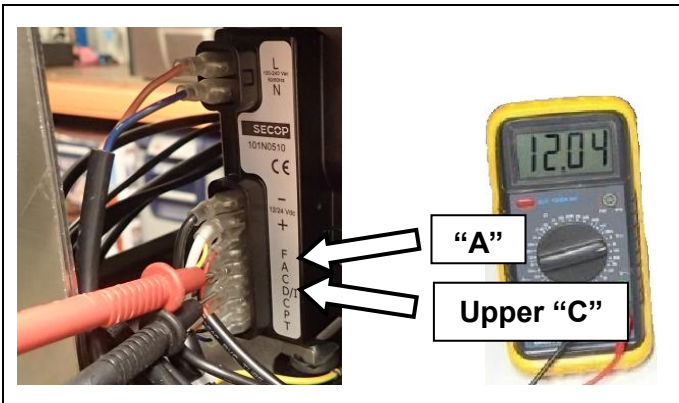
	<p>Using a DC voltmeter, check that approximately 12V DC is measured between terminals “A” and upper “C” on the compressor control unit.</p> <p>NOTE: <i>The voltage measurement may vary depending on the sensitivity of the DC voltmeter.</i></p>
---	--

TEST PASS – 12V DC IS MEASURED BETWEEN TERMINALS “A” AND UPPER “C”

With 100-240V AC power supplied to terminals “L” and “N”, approximately 12V DC should be measured between terminals “A” and upper “C”. In this case, the AC power section of the control unit is functioning correctly.

The compressor control unit has now been eliminated as a possible fault.

TEST FAIL – 12V DC IS NOT MEASURED BETWEEN TERMINALS “A” AND UPPER “C”

With 100-240V AC power supplied to terminals “L” and “N”, approximately 12V DC is not measured between terminals “A” and upper “C”. In this case, the AC power section of the control unit is faulty.

The compressor control unit has been identified as faulty and should be replaced (refer to section [9.4](#)).

Replace the control unit and repeat this test.

8.5 Test compressor

Purpose: To verify that the internal compressor windings are functioning correctly.

Procedure: See below.

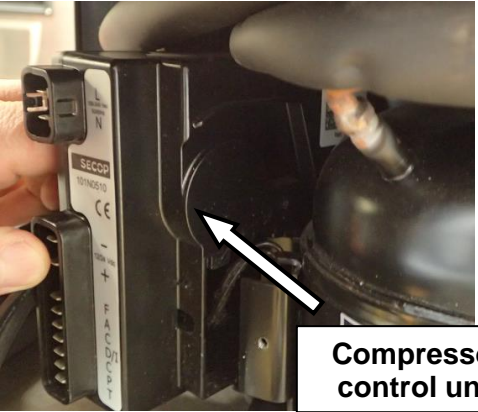
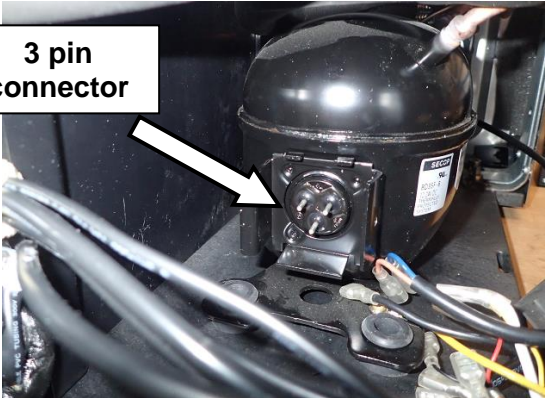
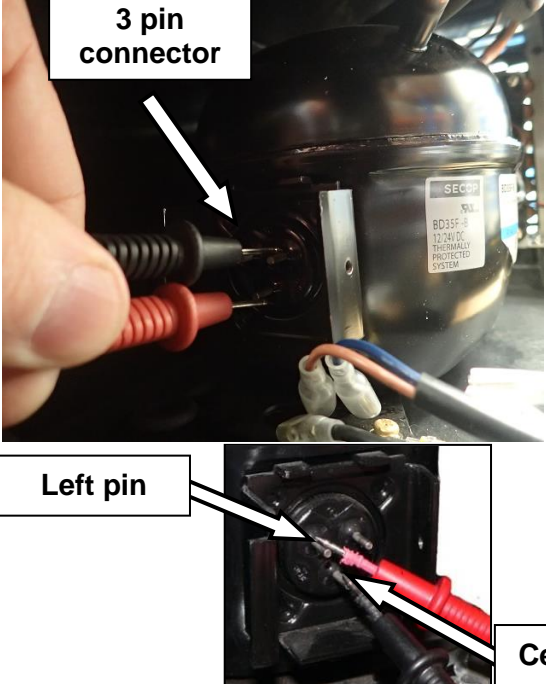
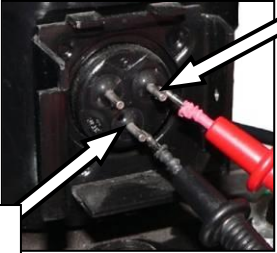
 <p>Compressor control unit</p>	<p>Disconnect all power leads from the back of the fridge.</p> <p>Remove the rear cover (refer to section 9.3).</p> <p>Remove the compressor control unit (refer to section 9.4).</p>
 <p>3 pin connector</p>	<p>Identify the 3-pin connector on the side of the compressor.</p>
 <p>3 pin connector</p> <p>Left pin</p> <p>Centre pin</p>	<p>Using an ohm meter (Ω), test the resistance of the two motor windings using the following process.</p> <ol style="list-style-type: none"> 1. Measure the resistance between the centre and left pins. The reading should be between approximately 2.0 and 2.5 ohms (Ω). 2. Measure the resistance between the centre and right pin. The reading should be between approximately 2.0 and 2.5 ohms (Ω).  <p>Right pin</p> <p>Centre pin</p>

TEST PASS



If resistance across both windings is approximately 2.0-2.5 ohms (Ω), compressor windings are OK.

TEST FAIL

If either winding shows an open circuit, the compressor is faulty and should be replaced.

8.6 Test thermistor

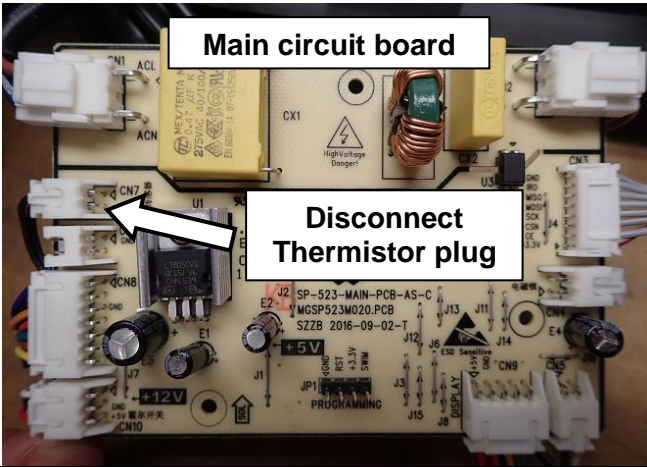
Purpose: To verify that the thermistor is operating correctly.

 <p>Main circuit board</p> <p>Disconnect Thermistor plug</p>	<p>Disconnect all power leads from the back of the fridge.</p> <p>Remove main circuit board (refer to section 9.5).</p> <p>Locate and disconnect the 2 pin male thermistor plug within the main circuit board.</p>
 <p>Thermistor plug</p>	<p>Using an ohm meter (Ω), measure the resistance value of the thermistor.</p> <p>To do this, measure the resistance between the two metal contacts in the plastic connector plug as shown.</p> <p>NOTE: The resistance of the thermistor will increase as the fridge gets colder.</p> <p>Measure the temperature of the plastic liner at the base of the fridge.</p>

<p>Thermistor resistance values</p>		<p>Check the measured resistance against the resistance values in the table for the given temperature.</p> <p>NOTE: Allow a variation of $\pm 5k \Omega$ between the measured resistance and the values in the table.</p>											
<table border="1"> <thead> <tr> <th>Temperature of plastic liner at base of fridge</th> <th>Resistance Value</th> </tr> </thead> <tbody> <tr> <td>10°C (50°F)</td> <td>18k Ω</td> </tr> <tr> <td>5°C (41°F)</td> <td>22k Ω</td> </tr> <tr> <td>0°C (32°F)</td> <td>28k Ω</td> </tr> <tr> <td>-5°C (23°F)</td> <td>35k Ω</td> </tr> <tr> <td>-10°C (14°F)</td> <td>44k Ω</td> </tr> </tbody> </table>	Temperature of plastic liner at base of fridge		Resistance Value	10°C (50°F)	18k Ω	5°C (41°F)	22k Ω	0°C (32°F)	28k Ω	-5°C (23°F)	35k Ω	-10°C (14°F)	44k Ω
Temperature of plastic liner at base of fridge	Resistance Value												
10°C (50°F)	18k Ω												
5°C (41°F)	22k Ω												
0°C (32°F)	28k Ω												
-5°C (23°F)	35k Ω												
-10°C (14°F)	44k Ω												

TEST PASS	
<p>If the measured resistance is within $\pm 5k \Omega$ of the tabulated value, the thermistor is functioning correctly.</p>	

TEST FAIL	
<p>If the measured resistance varies greatly from the tabulated value or an open circuit is detected, the thermistor is faulty and should to be replaced (refer to section 9.17).</p>	

8.7 Adjust internal temperature correlation





Purpose: To adjust the internal temperature calibration so that the display temperature matches the temperature at the base of the fridge.



This adjustment should only be necessary if the thermistor has been replaced.

NOTE : *A display temperature within 2-3°C (3.6-5.4°F) of the actual temperature at the base of the fridge is within normal on/off cycle temperature variation. If this is the case, the internal temperature calibration should not be changed.*

Procedure:

- Connect the fridge to 12/24V DC or 100-240V AC.
- Turn the fridge on.

- Press and hold  and  simultaneously until  or  appears on the display. The symbols displayed will depend on whether °C or °F is selected.

- Push  or  to adjust the setting by one 1°C or 2°F.

- Continue pressing  or  until the desired adjustment is made.

NOTE: *The internal temperature calibration adjustment is limited to up or down 4°C or 8°F.*

- After 5 to 6 seconds of inactivity, the display will flash twice and return to displaying the current target temperature.
- Allow the fridge to cycle on and off a few times to allow for any temperature lag.
- Check the temperature display against the temperature at the base of the cabinet.

CALIBRATION SUCCESSFUL

If the temperature display is within 2-3 °C (3.6-5.4°F) of the temperature at the base of the fridge, return the unit to the customer and advise that this is within normal on/off cycle temperature variation.

REPEAT CALIBRATION

If the temperature display is not within 2-3 °C (3.6-5.4°F) of the temperature at the base of the fridge, repeat the calibration procedure above.

9 SERVICE

9.1 Control panel circuit board – Remove and Replace.

The touch pad decal is an integral sealing component used to reduce water ingress around the electronic control panel. The touch pad is a single use item only. ARB recommends removing and replacing a damaged touch pad to maintain sealing integrity.



Peel back control panel touch pad to expose mounting screws.

Peel touch pad back just enough to clear the screws (about 10 mm).

HINT: Use a sharp knife or blade to help peel back the touch pad.

NOTE: If the touch pad is damaged, replace it only after the control panel has been re-installed.



Remove 2 Phillips head screws.

These screws attach the control panel assembly to the body of the fridge.

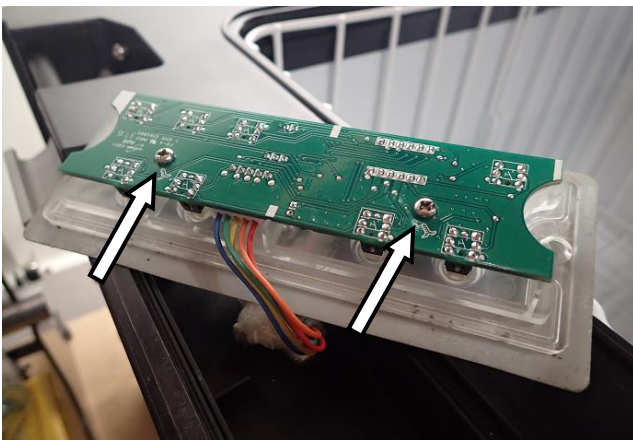

Remove control panel from fridge.

Remove 2 retaining Phillips head screws and remove circuit board from plastic control panel cover. Leave gasket seal in place.

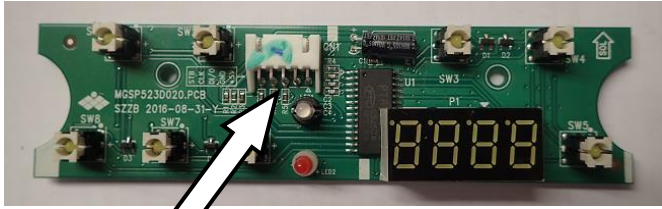

Main loom socket

Disconnect the main wiring loom from the control panel circuit board.

Connect main wiring looms to the new control panel circuit board.

Restore power to the fridge and test for correct operation.

NOTE: The power and temperature settings are stored within the main circuit board. If changing the circuit board to diagnose a possible fault, make sure that the settings on the new boards are correct.



Fit new control panel circuit board to plastic control panel cover using the same 2 screws. Do not over tighten the screws.

Install the control panel assembly into the body of the fridge and fasten using the same 2 screws, ensure gasket seal is correctly seated in recess.

Apply new control panel touchpad.

9.2 Control panel – Drain hole modification.

For extended operation in humid conditions, it may be necessary to drill additional drain holes in the cavity below the control panel touchpad. This will allow water created from condensation to drain and avoid failure of the control panel circuit board.



Remove the control panel from the fridge as described in section [9.1](#).

Once removed, check for water and condensation inside the control panel cavity. If the cavity is dry, this modification may not be necessary, however can still be completed as a precautionary measure.



Using a 7.5mm drill bit, drill two holes in the control panel cavity.

- Each hole should be drilled to a depth of 15mm.
- Each hole should be 25mm from the touchpad edges as shown.

HINT: To ensure the depth is correct, wrap tape around the drill bit at the correct height and drill down to the tape.

Thoroughly remove all swarf, ensure the cavity is clean and dry. Particularly check the rubber seal and ensure there are no particles which will reduce the sealing contact area.

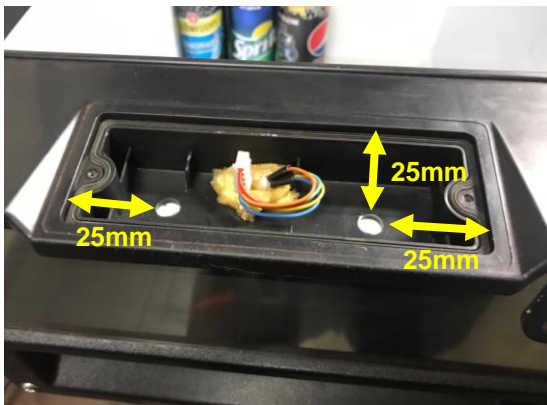

Refit control panel circuit board and touchpad as per section [9.1](#).

9.3 Rear Cover – Remove and Refit

To remove rear cover

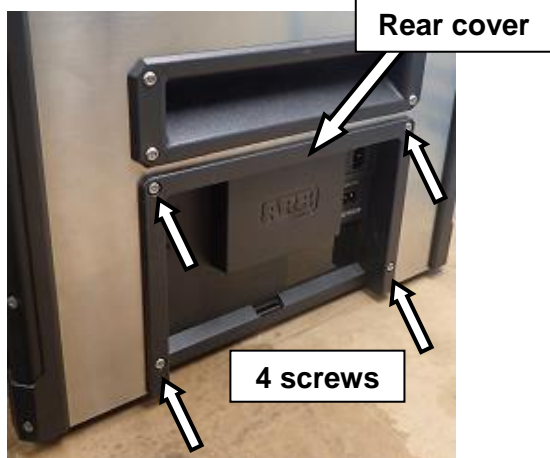

Disconnect all power leads from the back of the fridge.

Remove the 4 screws that connect the rear cover to the body of the fridge.



Pull the rear cover away from the body of the fridge.

CAUTION: Take care not to damage electrical wires or terminals.

To refit rear cover



Position rear cover against the body of the fridge so that the holes line up as shown.

Fasten the rear cover to the body of the fridge using the original 4 screws.

CAUTION: When refitting cover, ensure that all cables are securely fastened away from sharp, moving or hot surfaces.

9.4 Compressor control unit – Replace

For all fridge models



Disconnect all power leads from the back of the fridge.

Remove the rear cover (refer to section [9.3](#)).

Disconnect all 11 push on connectors from compressor control unit.

HINT: Use a pair of pliers to help release the connectors from the compressor unit terminals.



Remove 1 screw that connects the control unit to the compressor.

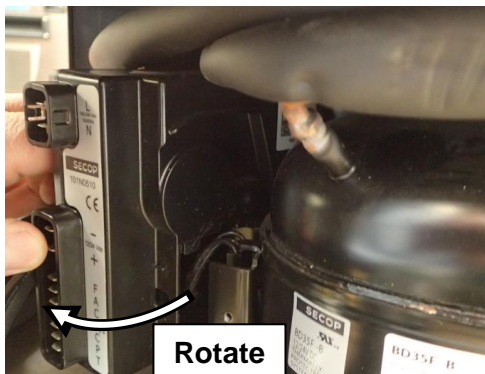

Remove the compressor control unit by rotating it away from the body of the fridge as shown.

HINT: Push-out side vent to allow easy access to the control unit. The vent has clips securing it in place. To remove, pull down on each clip and push from the inside.

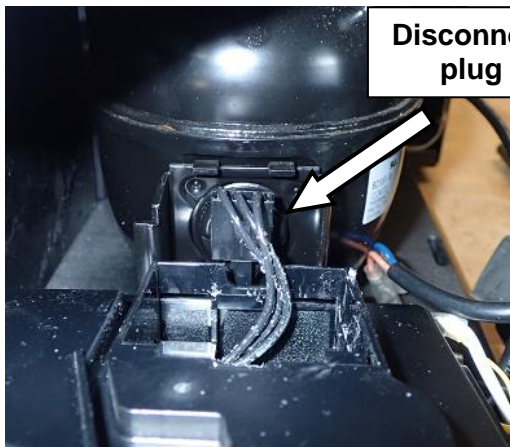

Disconnect the 3 wire plug that connects the compressor control unit to the compressor.



Connect the 3 wire plug from the new control unit to the compressor.

Fit new control unit to the compressor and attach using 1 Phillips head screw.

HINT: *When fitting control unit, locate back edge of unit on bracket and then rotate towards body of fridge as shown.*

'L' – BROWN	(AC Socket)
'N' – BLUE	(AC Socket)

'-' – BLACK	(DC Socket)
'+' – WHITE	(DC socket)
- YELLOW	(lower PCB)
- RED	(Fan)
'F' – BLACK	(Fan)
'A' – BROWN	(lower PCB)
'C' – GREEN	(lower PCB)
'D' – RED	(lower PCB)
'C' – ORANGE	(lower PCB)
'P' – BLACK	(lower PCB)
'T' – BLUE	(lower PCB)

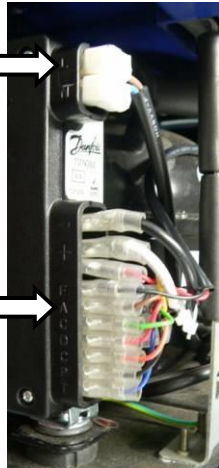

Connect the 11 connectors to the new control unit in the correct order (refer to diagram for wiring details).

Refit the rear cover.

Restore power to fridge and check for correct operation.

CAUTION: *Ensure that all cables are securely fastened away from sharp, moving or hot surfaces.*

9.5 Main circuit board – Replace

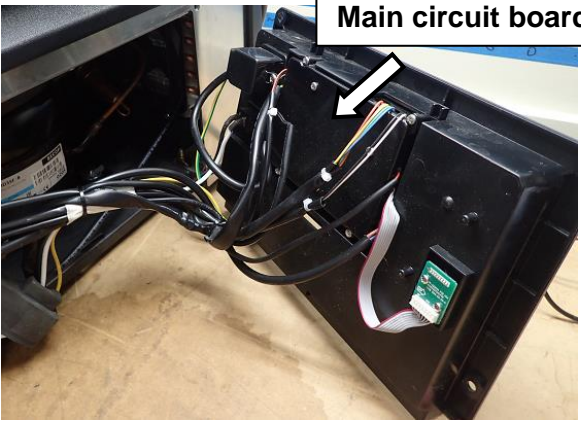
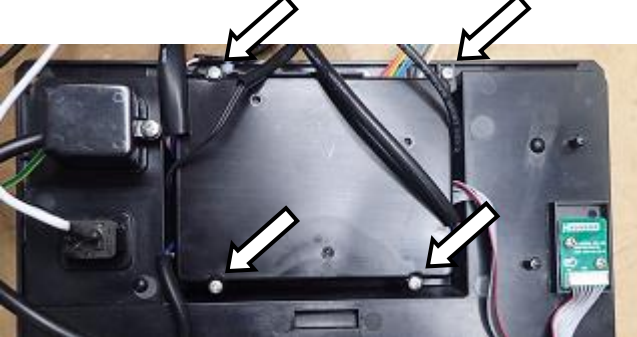
	<p>Disconnect all power leads from the back of the fridge.</p> <p>Remove the rear cover (refer to section 9.3).</p> <p>Locate the main circuit board installed on the rear cover.</p>
	<p>Remove 4 retaining screws from plastic cover.</p> <p>Remove plastic cover to expose main circuit board.</p>
	<p>Remove 3 retaining screws from main circuit board.</p> <p>Remove main circuit board.</p>
	<p>Disconnect all 9 connectors.</p> <p>Mark the location of each connector before disconnecting.</p> <p>Replace the main circuit board and reconnect all 9 electrical connectors.</p> <p>Install main circuit board into rear cover and install original 3 screws. Install plastic cover using the original 4 screws. Do not over tighten the screws.</p>



Reconnect the 9 electrical connectors.

Refit the rear cover.

Restore power to the fridge and test to confirm correct operation.

CAUTION: *Ensure that all cables are securely fastened away from sharp, moving or hot surfaces.*

MAIN PCB

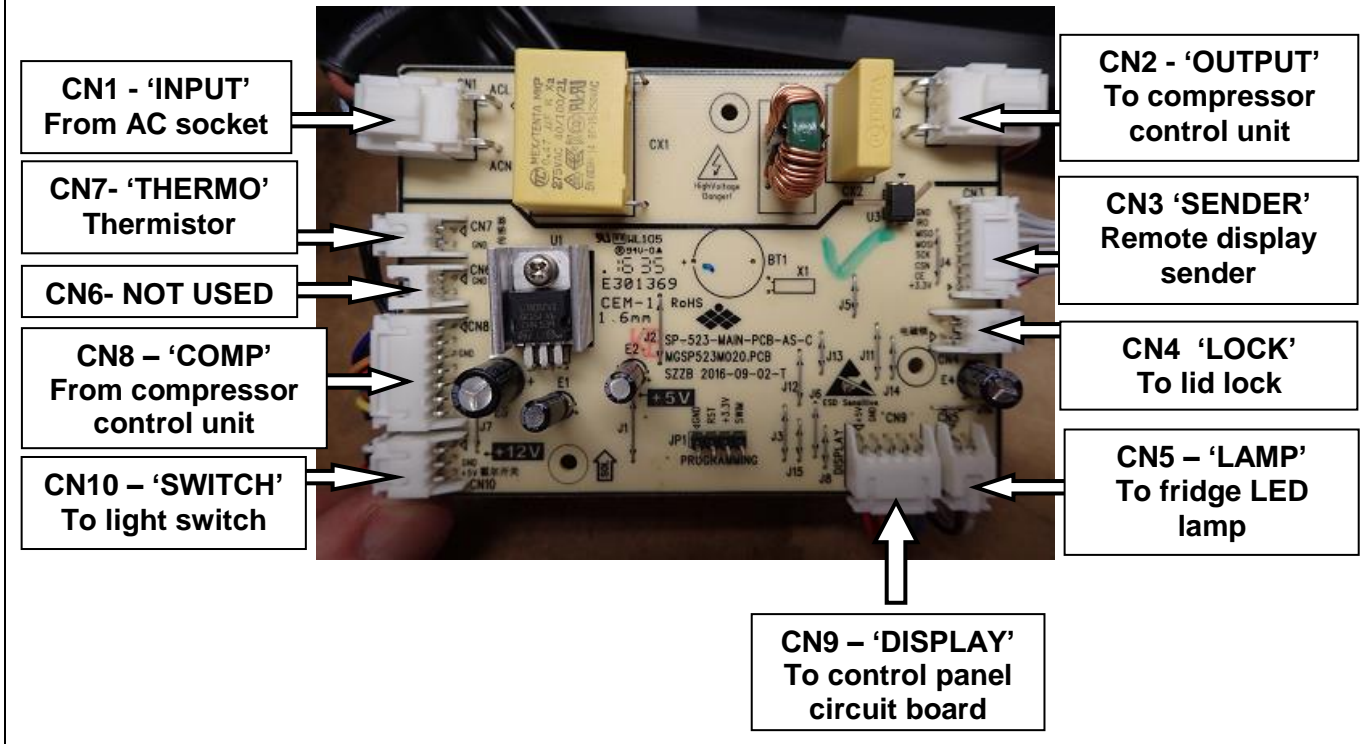

9.6 Rear Cover – Replace

Replace rear cover – to remove.



Disconnect all power leads from the back of the fridge.

Remove the rear cover (refer to section [9.3](#)).

CAUTION: Take care not to damage electrical wires or terminals.

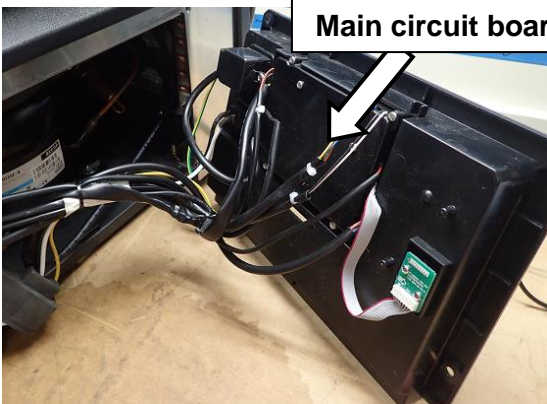

Main circuit board

Disconnect the main circuit board from rear cover (refer to section [9.5](#)).



Remove all 11 connectors

Disconnect all 11 push on connectors from compressor control unit.

HINT: Use a pair of pliers to help release the connectors from the compressor control unit terminals.

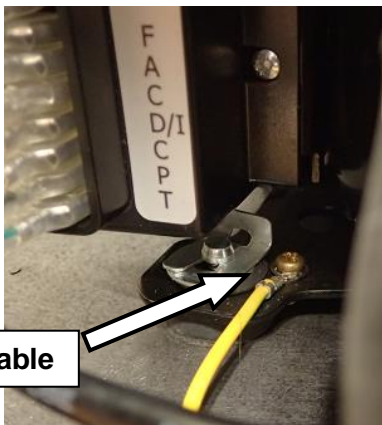

Earth cable

Disconnect the earth cable from the compressor mounting chassis.

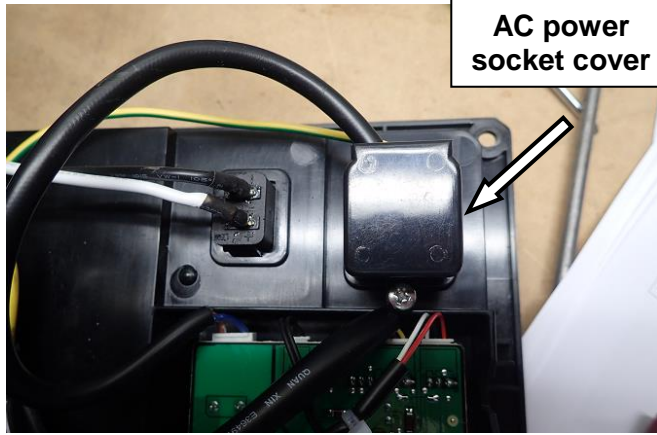

Remove the AC power socket cover.

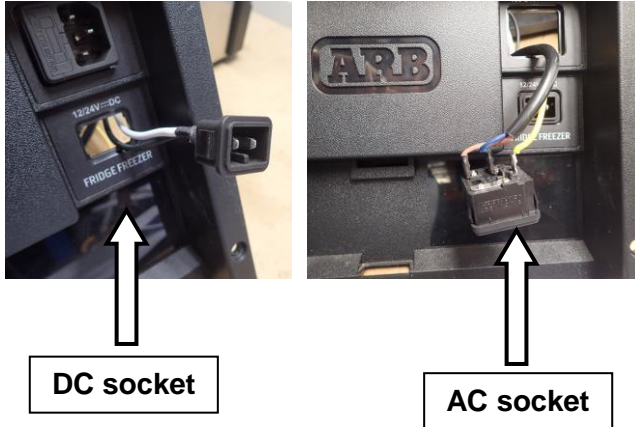

Remove the 12/24V DC socket. Withdraw the socket (complete with leads) through the hole in the rear cover as shown.

Remove 100-240V AC socket. Withdraw the socket (complete with leads) through the hole in the rear cover as shown.

HINT: Use a flat blade screw driver to depress the tabs on the back of the socket.

Discard old rear cover.

Replace rear cover – to refit

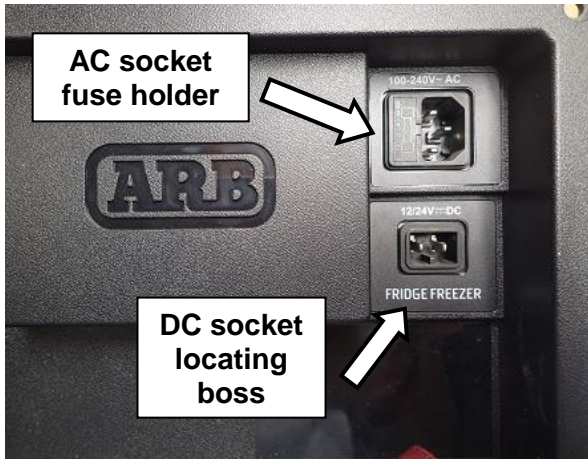

Fit the 12/24V DC and 100-240V AC sockets (complete with leads) to the new rear cover.

NOTE: Make sure that the fuse holder in the AC socket is at the top as shown.

NOTE: Make sure that the locating boss in the DC socket faces the outer edge of the fridge as shown.

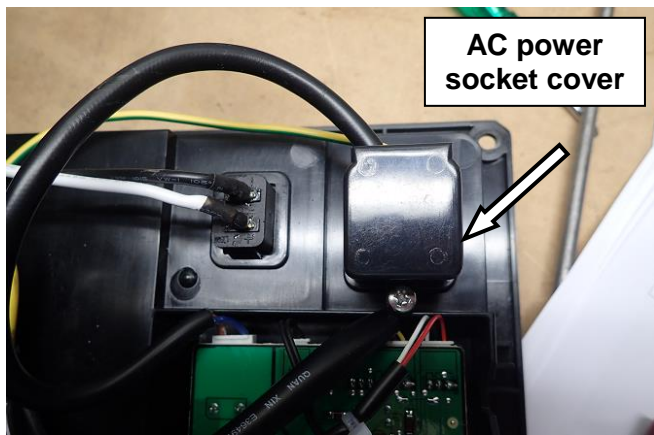

Refit the AC power socket cover.

Refit the earth cable to the compressor mounting chassis.

'L' – BROWN	(AC Socket)
'N' – BLUE	(AC Socket)

'-' – BLACK	(DC Socket)
'+' – WHITE	(DC socket)
- YELLOW	(lower PCB)
- RED	(Fan)
'F' – BLACK	(Fan)
'A' – BROWN	(lower PCB)
'C' – GREEN	(lower PCB)
'D' – RED	(lower PCB)
'C' – ORANGE	(lower PCB)
'P' – BLACK	(lower PCB)
'T' – BLUE	(lower PCB)

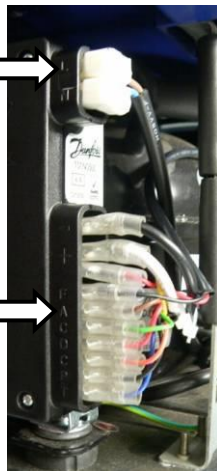

Reconnect the 11 connectors to the compressor control unit in the correct order (refer to wiring details).

Fit the main circuit board to the new rear cover. (refer to section [9.5](#))

9.7 Cooling fan - Replace

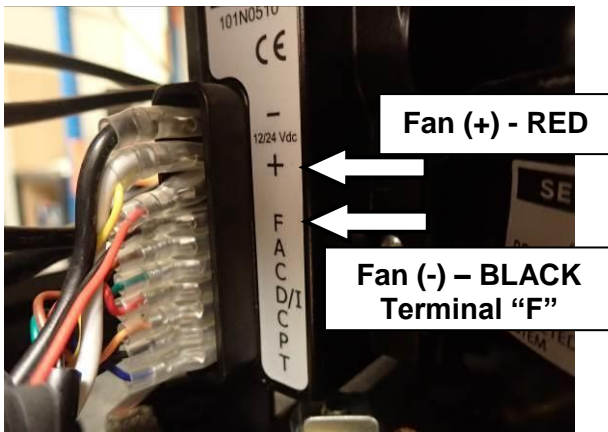

Disconnect all power leads from the back of the fridge.

Remove the rear cover (refer to section [9.3](#)).

Disconnect positive (+) and negative (-) fan wires from the compressor control unit as shown. The black fan wire is connected to terminal "F".

Connect the new fan to the control unit and confirm correct operation.

HINT: Do not install the new fan until the correct operation has been confirmed.

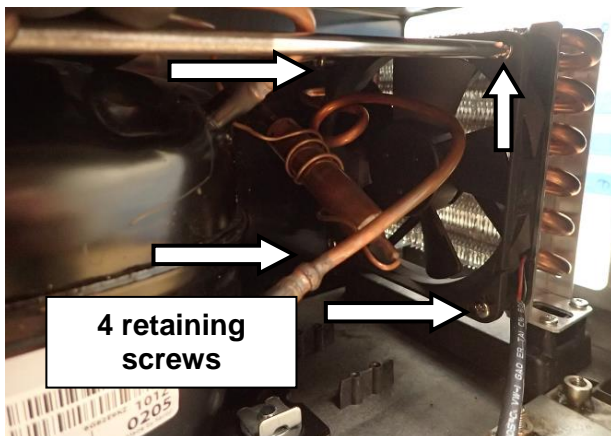

Remove 4 fan retaining screws that secure the fan to the condenser.

CAUTION: Take care not to stretch the refrigeration lines or power cables.



Remove fan.

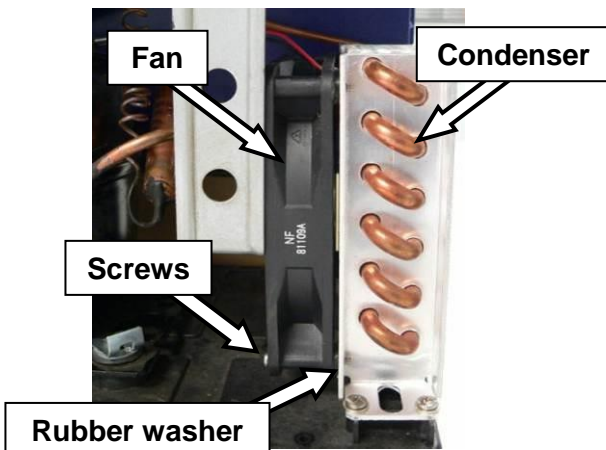

Fit the rubber washers between the new fan and the condenser as shown.

Install the new fan and fasten to the condenser using the original 4 screws.

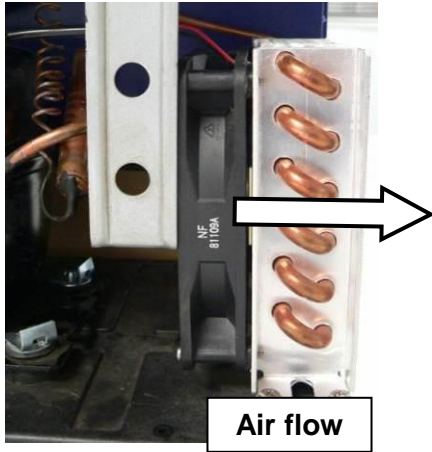

Position the fan with the cable recess at the top as shown.

Install the fan electrical connectors into the compressor control unit.

Make sure that the airflow direction marked on the fan is pointing towards the condenser.



Refit the rear cover.

CAUTION: *Ensure that all cables are securely fastened away from sharp, moving or hot surfaces.*

CAUTION: *Make sure that all refrigeration lines are not under pressure and do not contact other parts of the fridge.*

9.8 LED – Replace



Disconnect all power leads from the back of the fridge.

Position the basket to provide access to the light housing. This may require removing the basket.

Remove the transparent light housing from internal case of the fridge.

HINT: Place your finger under the lip of the light housing and ease it away from the internal case of the fridge.

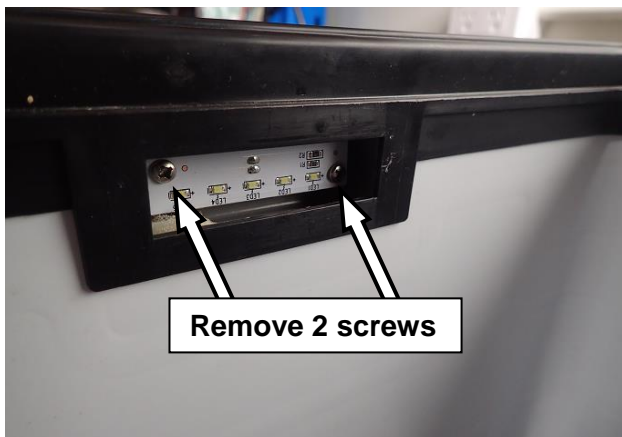

Remove 2 retaining screws from LED circuit board assembly.

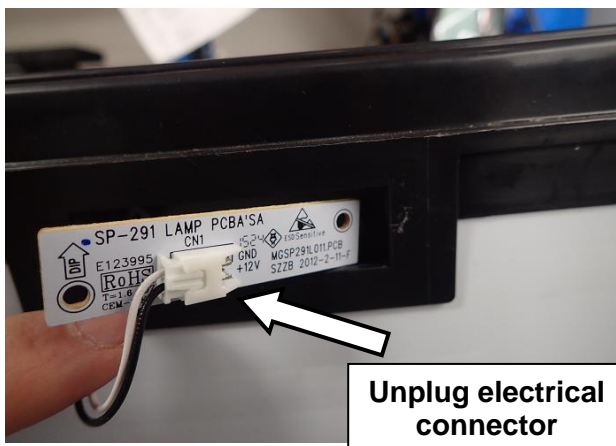

Remove LED circuit board from fridge and locate the electrical plug.



Disconnect electrical plug from old LED circuit board.



Install plug into new LED circuit board and reinstall old retaining screws into new.

Refit light housing into cabinet of fridge.

9.9 Plug fuse (12/24V DC) – Replace

	<p>Disconnect the 12/24V DC power lead from all power supplies.</p>
	<p>Unscrew end of plug from housing.</p>
	<p>Separate plug and housing. Remove fuse from plug.</p> <p>Replace the device fuse with a new fuse of the same rating. Fuse rating DC Glass 12/24V 15Amp</p> <p>Reassemble the plug and test for continuity.</p>

9.10 Device fuse (100-240V AC) – Replace



Remove the AC and DC power leads from the power sockets.

Remove the fuse insert from the rear panel of the fridge as shown.

HINT: A small flat blade screwdriver may be required to help pry the insert away from its housing.



Replace the defective fuse with a new fuse that has the same rating. The correct rating for the fuse is 4A, specified as: F4L250V.

Replace the fuse insert back into its housing

9.11 DC power socket – Replace



Disconnect all power leads from the back of the fridge.

Remove the rear cover (refer to section [9.3](#)).

Withdraw the socket (complete with leads) through the hole in the rear cover as shown.

HINT: Use a flat blade screw driver to depress the tabs on the back of the socket.

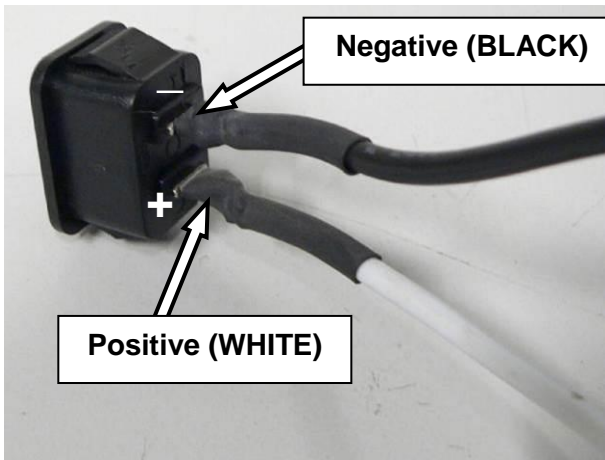

Disconnect the positive (white) and negative (black) wires from the terminals on the back of the DC socket using a soldering iron.

Connect the positive (white) and negative (black) wires to the new DC power socket using a soldering iron. The terminals on the back of the socket are labelled "+" (positive) and "-" negative.

IMPORTANT: Make sure that the wires are securely soldered to the correct terminals.

Apply heat shrink insulation to the exposed sections of wire.



Restore power to the fridge and confirm correct operation of the socket.

Refit the DC socket into the rear cover. Ensure that the locating boss faces towards the base of the fridge.

9.12 AC power socket – Replace



Disconnect all power leads from the back of the fridge.

Remove the rear cover (refer to section [9.3](#)).

Remove the AC socket protector.

Withdraw the socket (complete with leads) through the hole in the rear cover as shown.

HINT: Use a flat blade screw driver to depress the tabs on the back of the socket

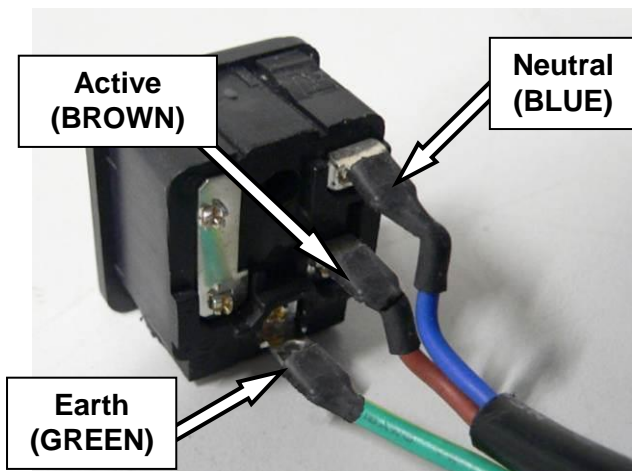

Disconnect the 3 wires from the back of the AC power socket using a soldering iron.

Connect the 3 wires to the new AC power socket using a soldering iron (refer to diagram for wiring details).

Apply heat shrink insulation to the exposed sections of wire.

NOTE: Termination of the AC cables to the AC socket should only be performed by a licensed electrician.



Refit the socket into the rear cover. Ensure that the fuse housing is to the left as shown.

9.13 Rubber feet – Remove and Refit

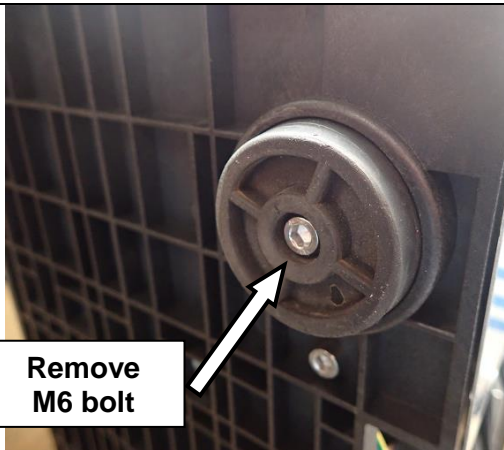

Remove 1 M6 bolt from the centre of the rubber foot using a 5 mm hex key.



Remove the rubber foot from the recess in the base of the fridge.

Install the new rubber foot into the recess in the base of the fridge.

NOTE: When tightening the M6 bolt, do not exceed an assembly torque of 3.5 Nm (2.5 ftlb).

9.14 Compressor mounting feet – Replace

To Remove compressor mounting feet



Disconnect all power leads from the back of the fridge.

Remove the rear cover (refer to section [9.3](#)).

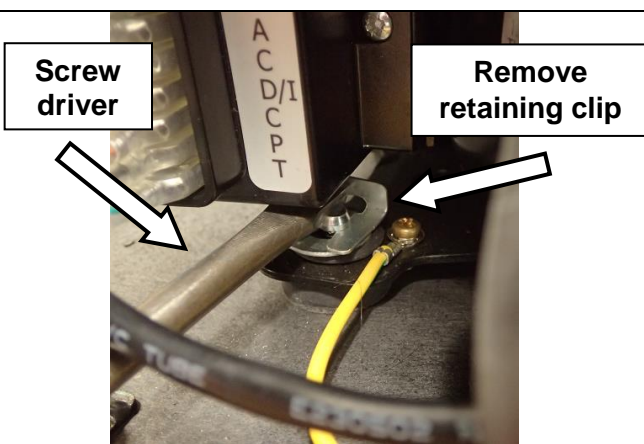

Remove the retaining clip by sliding it sideways off the pin.

HINT: A flat blade screwdriver may be useful to help remove the retaining clip.

HINT: Press down on the steel compressor base to compress the rubber mounting bush.

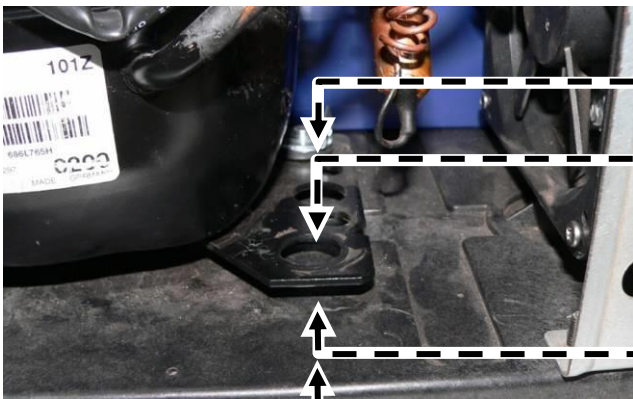

Withdraw the pin, washer and rubber bush.

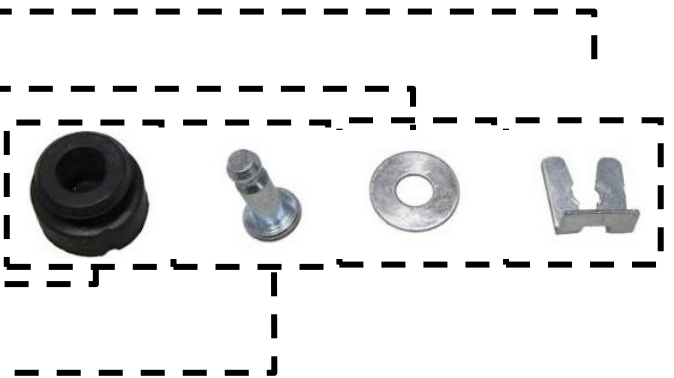

To refit compressor mounting feet

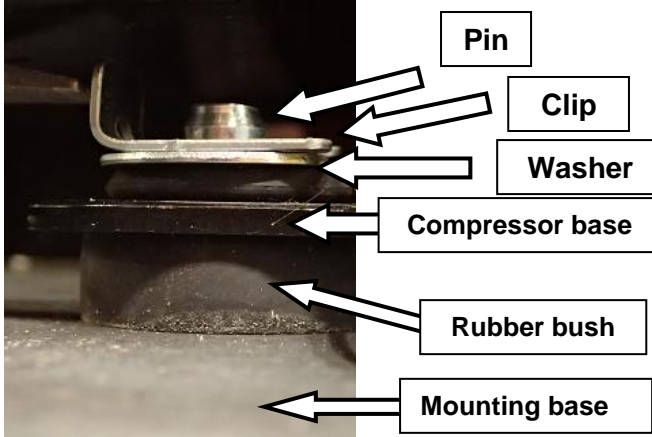

Locate the rubber bush between the steel compressor base and the mounting base as shown.

NOTE: The small end of the rubber bush should locate within the steel base of the compressor.

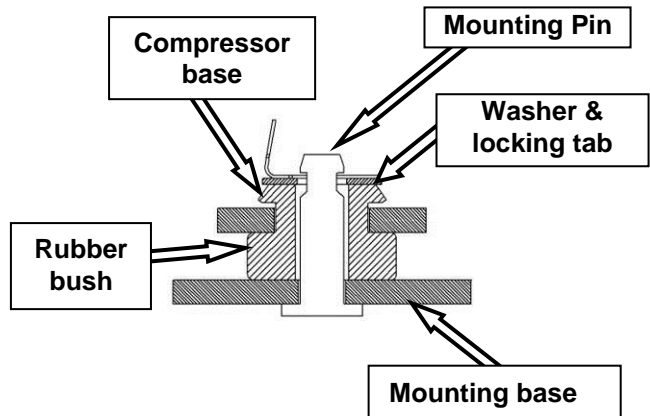

Insert the pin through the mounting base, steel compressor base and rubber bush.

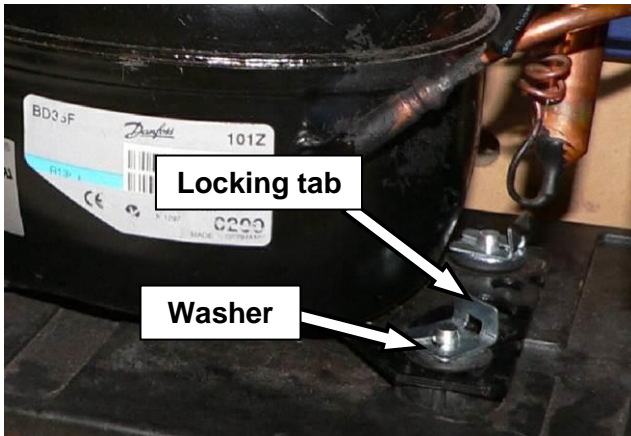

Place the washer over the pin and secure with the locking tab.

HINT: Temporary compression of the rubber bush will assist with fitting the locking tab.

HINT: A small g-clamp may be useful to help compress the rubber bush.

CAUTION: When compressing the bush, take care not to damage the mounting base or the steel compressor base.



Refit the rear cover.

CAUTION: When refitting cover, ensure that all cables are securely fastened away from sharp, moving or hot surfaces.

9.15 Compressor mounting base – Replace



Disconnect all power leads from the back of the fridge.

Remove the rear cover (refer to section [9.3](#)).

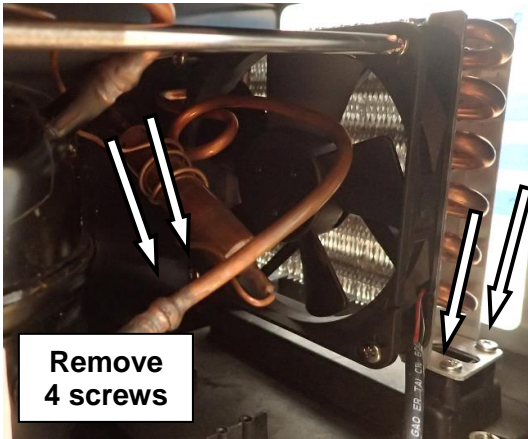

Remove 4 screws that fasten the condenser to the mounting base.

CAUTION: Take care when handling the condenser assembly not to stretch the refrigeration lines or power cables.





Separate the compressor from the mounting base by releasing the 4 rubber compressor mounts (refer to section [9.14](#)).

CAUTION: Take care when handling the compressor not to stretch the refrigeration lines or power cables.

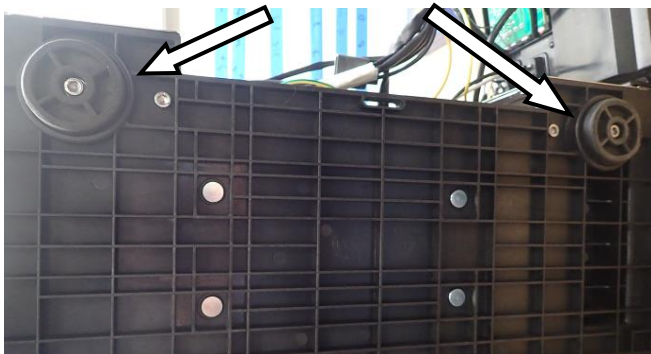
Remove 2 rubber feet

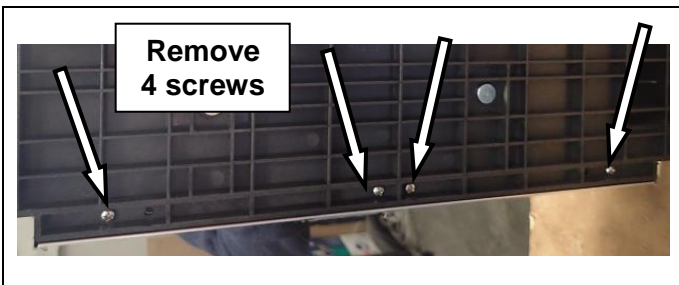
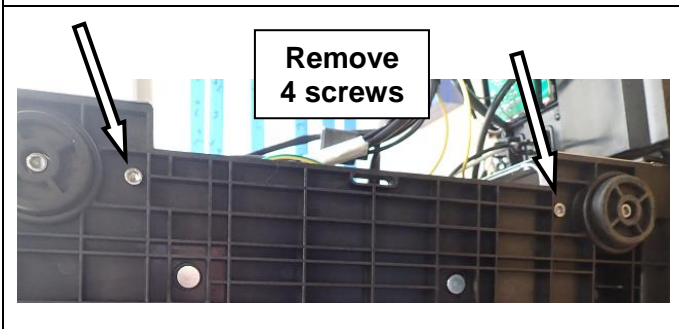

Remove 2 rubber feet from compressor mounting base. Retain both the rubber feet and the fastening bolts.

	<p>Remove 4 screws from underside of the fridge. These screws fasten the mounting base to the fridge.</p>
	<p>Remove 2 screws from underside of the fridge. These screws fasten the mounting base to the fridge.</p> <p>Discard old compressor mounting base.</p>
	<p>Fit the 2 rubber feet to the new compressor mounting base using the original fasteners.</p> <p>Fit the compressor and condenser to the new mounting base using the original fasteners.</p> <p>Fit 4 retaining screws to base of fridge using original fasteners.</p> <p>Refit the rear cover.</p> <p>CAUTION: <i>When refitting the rear cover, ensure that all cables are securely fastened away from sharp, moving or hot surfaces.</i></p>

9.16 Lid seal – Remove and Refit

Lid seal - To Remove



Locate and mark the join in the lid seal as shown.



Using fingers, grip the seal and pull it away from the lid.

Lid seal - To Refit



Starting at the marked point, press the seal into the groove.

NOTE: The seal should be orientated with the groove on the side as shown.

The lid seal is cut to the correct length and should fit exactly into the groove.

If the seal is too long, it may have been over-stretched. Remove the seal and refit it without stretching.

If the seal is too short, remove the seal and replace while stretching it slightly.

9.17 Thermistor – Replace



Disconnect all power leads from the back of the fridge.

Remove the rear cover (refer to section [9.3](#)).



Remove side vent to allow access to right hand side of fridge.

HINT: *The vent has clips securing it in place. To remove, pull down on each clip and push from the inside.*



Screw and
"P" clip

Remove and retain the screw, "P"-clip and sealing compound that retain the thermistor wire.

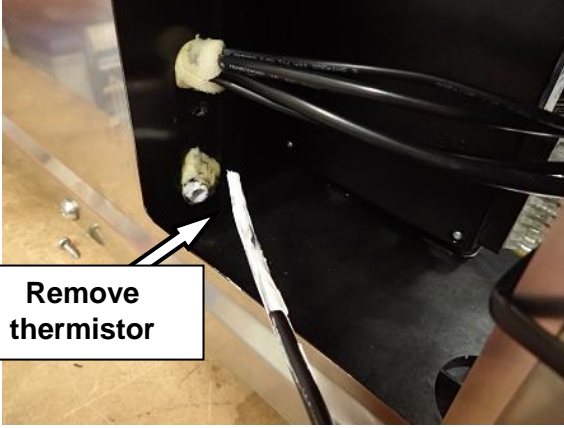

Remove thermistor

Place a mark on the thermistor wire where it exits the fridge cabinet. The new installed wire length will need to match the old wire length.

Withdraw the thermistor wire and thermistor from the fridge cabinet.

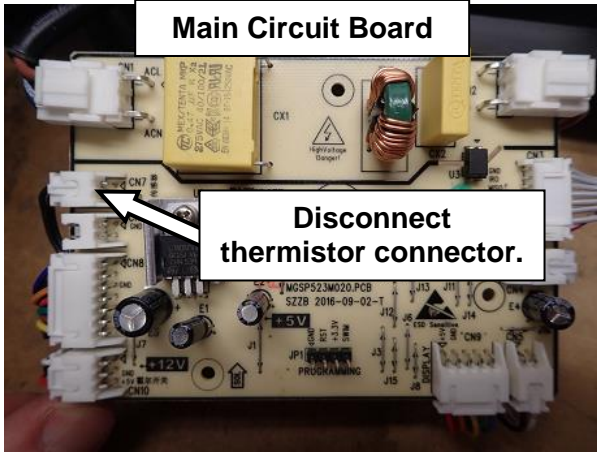

Main Circuit Board

Disconnect thermistor connector.

Gain access to the main circuit board as per section [9.5](#).

Disconnect the 2-pin connector from the main circuit board. Remove the thermistor wire (complete with thermistor) from the fridge. Take note of the thermistor wire path.

Insert new thermistor plug into main circuit board. Reassemble circuit board into the rear cover as per section [9.5](#).

NOTE: It may be necessary to remove cable ties that have been used to secure the thermistor wire to the main wiring loom.

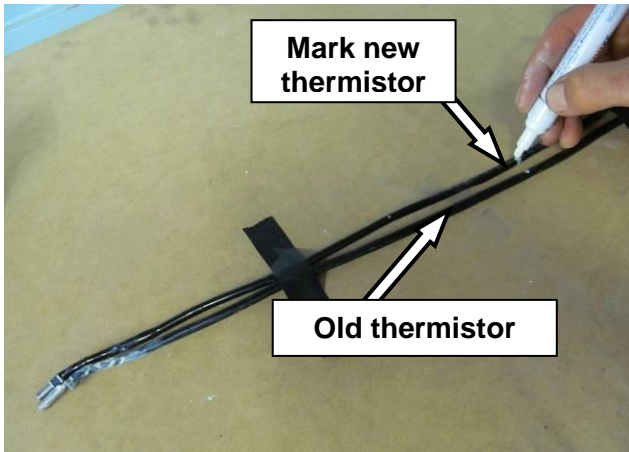

Mark new thermistor

Old thermistor

Place the old thermistor alongside the new one.

Transpose the mark made in the previous step from the old thermistor wire onto the new one.



Apply heat transfer paste

Apply thermal heat transfer paste to the metallic end of the thermistor as shown.

This paste is available from Jaycar (p/n NM-2012)

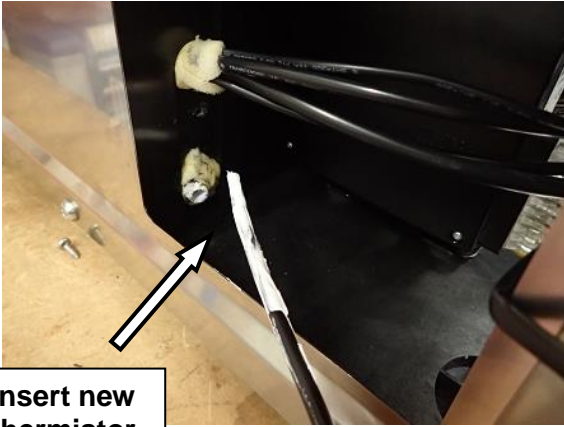

Insert new thermistor

Insert the new thermistor into the hole in the fridge cabinet.

Continue to insert the thermistor wire until the mark made in the previous step lines up with the body of the fridge.



Screw, "P" clip & sealing compound





Secure the thermistor wire in place with the "P"-clip, screw and sealing compound.

Install the new thermistor wire into the fridge using the same path as the old wire. Secure the thermistor wire main wiring loom using cable ties.

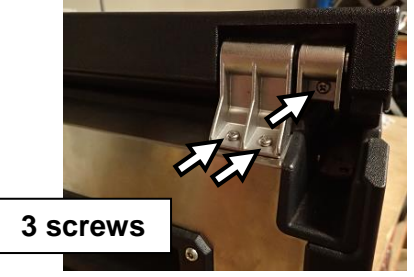

Reassemble vent and rear cover as per section [9.3](#).

CAUTION: Ensure that all cables are securely fastened away from sharp, moving or hot surfaces.

9.18 Hinge – Remove and Refit



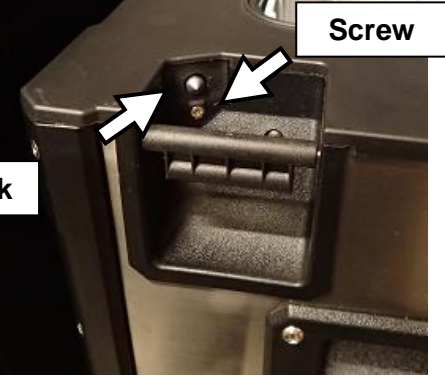
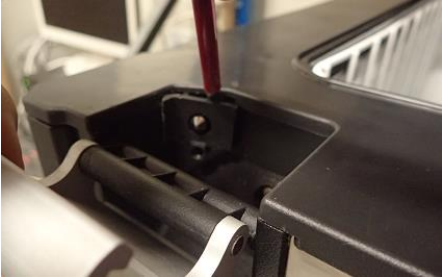
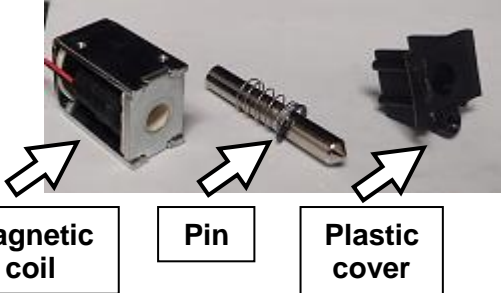
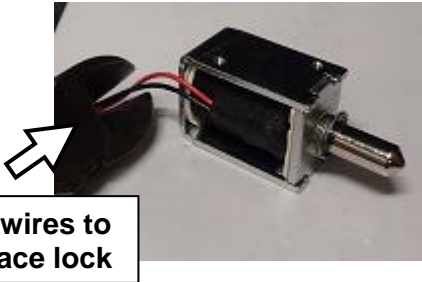

 <p>4 screws</p>	<p>Open lid to gain access to inside of hinge screws.</p> <p>Remove 4 screws with screw driver.</p>
 <p>3 screws</p>	<p>Close lid to gain access to the outside of hinge screws.</p> <p>Remove 3 screws with screw driver.</p>
	<p>Slide hinge out from rear with lid closed.</p>
	<p>Clean and inspect hinge for damage, particularly the pin alignment.</p> <p>Discard and replace as required.</p>
	<p>Slide hinge into fridge from rear with lid closed.</p>
	<p>Check alignment of lid, ensure lid seal aligns with fridge seal protrusion on base as shown.</p> <p>Install screws in reverse order to disassembly. Reuse old screws and tighten.</p>

9.19 Lock Assembly – Remove, Inspect and Refit

	<p>Disconnect the 12/24V DC and 240V AC power lead from the all power supplies.</p> <p>Open the fridge lid and identify the lock.</p> <p>Using a screw driver, remove the screw below the lock assembly.</p>
	<p>With a screw driver, pry out the lock assembly.</p>
	<p>Check the pin can slide freely with the magnetic coil. There should some magnetic pull on the pin holding the pin inside the coil.</p>
	<p>To replace, the two wires entering the coil will need to be cut.</p> <p>The new lock mechanism will require the wires to be soldered onto the old fridge wires.</p>
	<p>Insert lock mechanism into fridge with pin installed.</p> <p>Insert plastic cover and screw securing the lock in place.</p> <p>Check lock engages and disengages as per normal operation.</p>

9.20 Factory Reset – Lock Password Reset.

For situations when the Lock password has been lost or forgotten and the fridge has been inadvertently locked; the below procedure can be used to reset the password and open the fridge.

	<p>If not already complete, close the lid and engage the lock as per procedure in operators and service manual.</p>
	<p>Disconnect power source from rear of fridge.</p>
	<p>Open latch on left front corner of fridge and locate the screw behind the latch.</p> <p>Unscrew Philips head screw and remove.</p>
	<p>Use thin punch and push into screw hole located behind latch.</p> <p>This will push the locking pin into the disengaged position and enabling the fridge to open.</p>



Open fridge lid and prop ensuring the light will illuminate when the power is restored.



Connect power source to rear of fridge.

Although the locking pin is disengaged, the fridge perceives the lock as engaged and lid as open. This is an impossible scenario which triggers the factory reset.

Once power is restored, the locking mechanism will engage and disengage (slide in and out). This signal indicates the password has been reset.



The Lock password will be reset to default factory setting:



The password can now be reset by pressing the Lock button as per normal procedure.

Please follow the operators and service manual procedure to reset the password.

10 SERVICE BY REFRIGERATION MECHANIC

10.1 Compressor recharge information

The ARB fridge freezer range as designated in this manual use refrigerant R134a.

Model	60L(63 qrt)
Type	10800050
R134a g/(oz)	68/(2.40)

10.2 Leaks in the refrigerant system.

If low refrigerant is suspected, the system should be pressure tested.

If the pressure test identifies a leak, the location of the leak should be found.

To locate the leak, the refrigerant system should be split into two sections (see below) and pressure tested separately.

Section 1 - All refrigerant lines and components external to the foamed cabinet. This includes the compressor and condenser.

Section 2 - The evaporator and all refrigerant lines inside the foamed cabinet.

If the refrigerant leak is located externally of the evaporator and foamed cabinet (section 1), the leak may be repaired. If the fridge is inside the warranty period a complete replacement is required.

If a refrigerant leak is detected inside the evaporator or foamed cabinet (section 2), the fridge should be replaced.

11 WIRING

11.1 Wiring diagram

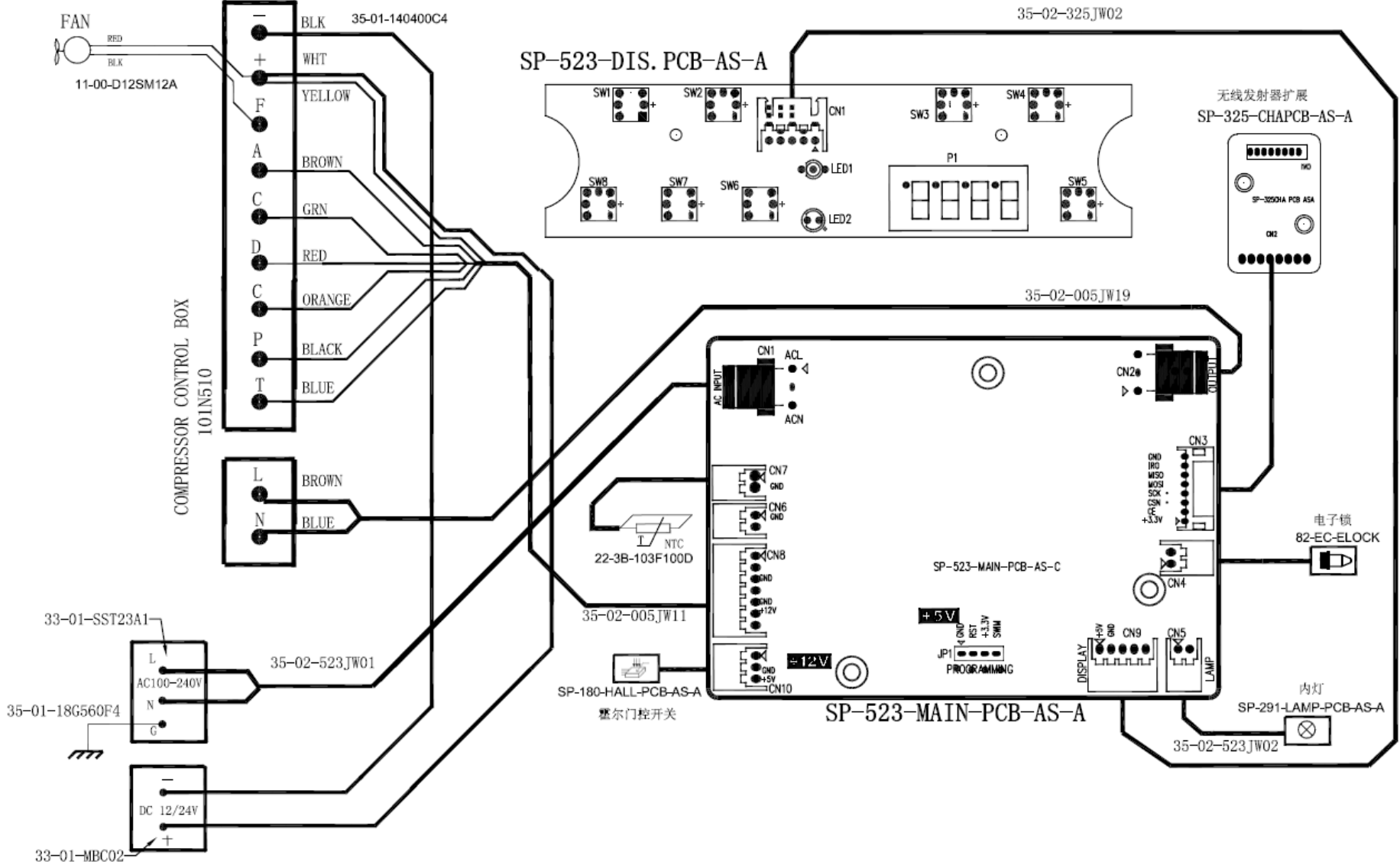

11.2 Wiring schematic – Main Circuit Board.

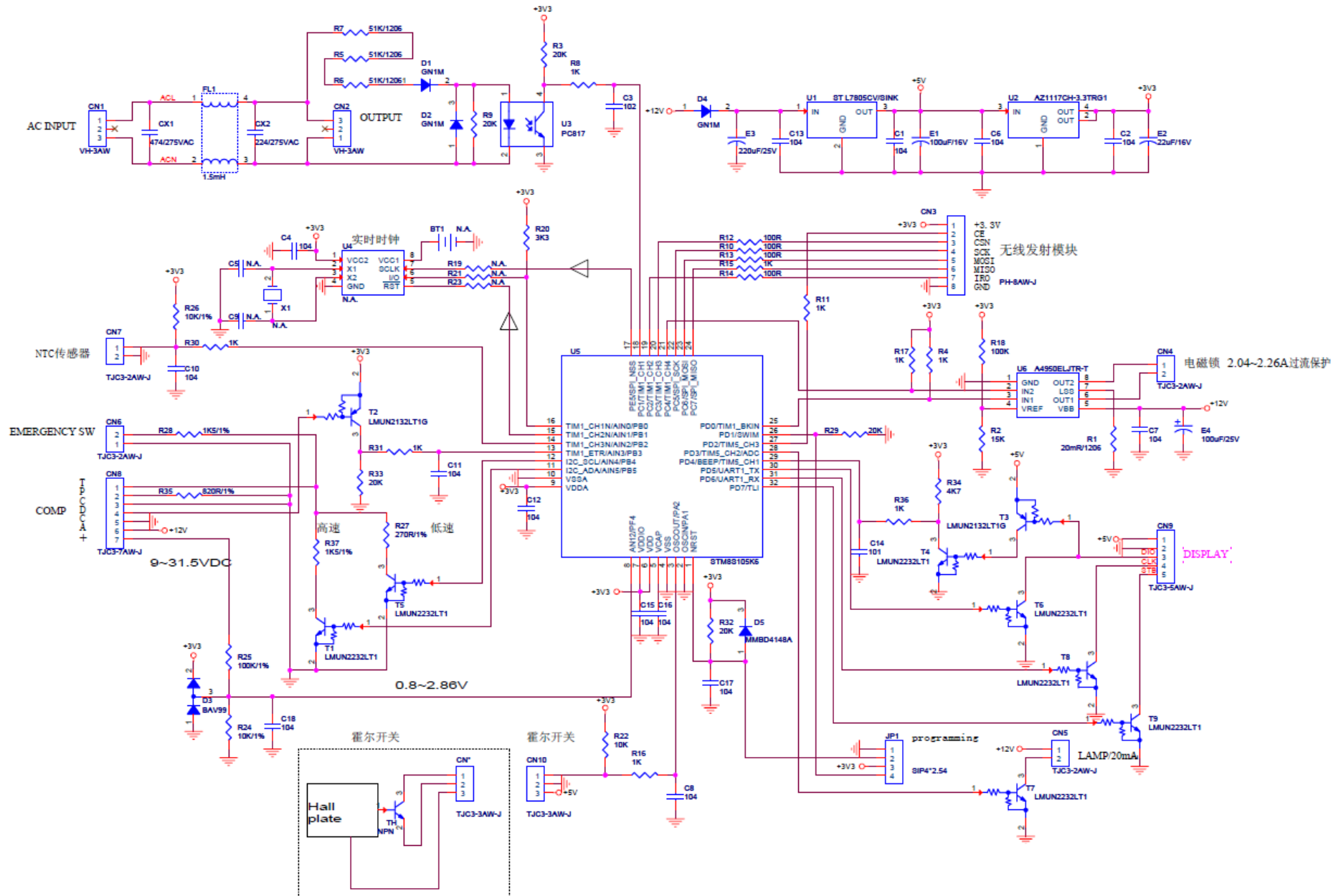

11.3 Wiring schematic – Display Circuit Board.

