



INSTALLATION INSTRUCTIONS

Trans4mer Winch Mount For 2007 -2010 Chevrolet Silverado HD and GMC Sierra HD

Bracket Kit 90140

Your safety, and the safety of others, is very important. To help you make informed decisions about safety, we have provided installation and operating instructions and other information on labels and in this guide. This information alerts you to potential hazards that could hurt you or others. It is not possible to warn you about all potential hazards associated with this product, you must use your own good judgment.

CARELESS INSTALLATION AND OPERATION CAN RESULT IN SERIOUS INJURY OR EQUIPMENT DAMAGE. READ AND UNDERSTAND ALL SAFETY PRECAUTIONS AND OPERATING INSTRUCTIONS BEFORE INSTALLING AND OPERATING THIS PRODUCT.

This guide identifies potential hazards and has important safety messages that help you and others avoid personal injury or death. **WARNING** and **CAUTION** are signal words that identify the level of hazard. These signal words mean:

⚠ WARNING signals a hazard that could cause serious injury or death, if you do not follow recommendations.

⚠ CAUTION signals a hazard that may cause minor to moderate injury, if you do not follow recommendations.

This guide uses **NOTICE** to call attention to important mechanical information, and **Note**: to emphasize general information worthy of special attention.

⚠ WARNING

INJURY HAZARD

Failure to observe these instructions could lead to severe injury or death.

- Always** use extreme caution when drilling on any vehicle. Make sure that all fuel lines, brake lines, electrical wires, and other objects are not punctured or damaged when/if drilling on the vehicle. Thoroughly inspect the area to be drilled (on both sides of material) prior to drilling, and relocate any objects that may be damaged. Failure to inspect the area to be drilled may result in vehicle damage, electrical shock, fire or personal injury.
- Always** wear safety glasses when installing this kit. A drilling operation will cause flying material chips. Flying chips can cause eye injury.
- Always** use extreme caution when cutting and trimming during fitting.
- Always** remove jewelry and wear eye protection.
- Always** use appropriate and adequate care in lifting components into place.
- Never** lean over battery while making connections.
- Always** insure components will remain secure during installation and operation.
- Always** tighten all nuts and bolts securely, per the installation instructions.

⚠ WARNING

Failure to observe these instructions could lead to severe injury or death.

- Always** securely tighten all bolts on the winch plate, winch, and fairlead. Loose bolts can result in product failure which may result in vehicle damage and operator injury or death.
- Always** double check, that all bolts are securely tightened prior to use.

⚠ Caution

Moving Parts Entanglement Hazard

Failure to observe these instructions could lead to minor or moderate injury.

- Always** take time to fully read and understand the installation Instructions included with this product.

Read installation instructions thoroughly.

Notice

Equipment Damage

- Always** refer to the Operator's Manual, supplied in the winch kit, for all wiring schematics and specific details on how to wire a WARN winch product to your vehicle.

Read Operating Manual thoroughly.

This WARN Trans4mer Gen II system can be customized to give your vehicle a wide variety of looks, front-end protection and winch mounting capability. The system starts with this winch carrier that attaches to the truck's frame with brackets designed to handle up to a 16500 lb winch on some vehicles. This provides a mounting location for a Warn winch. It is durable and good looking as a stand-alone winch mount, but can be easily upgraded with some great options! You can first add a center Grille Guard Tube that provides a mounting location for other accessories. You can add a light bar that adds even more protection and includes tabs for mounting auxiliary lights. You can mount a front receiver bracket that provides a mounting location for a multi-mount Warn winch. Finally, headlamp guards that protect the headlights and front corners of the vehicle can be easily added to the grille guard.

Before You Begin

- Read and understand these Installation Instructions.
- Refer to the Parts List below and to Figures A, B, and C for your specific mounting system to become familiar with the components and hardware in this kit.

I. PARTS LIST FOR 90140 Bracket Kit

<u>Part Number.</u>	<u>Qty</u>	<u>Description</u>
80976	1	Frame Extension, LH
80977	1	Frame Extension, RH
81377	1	Hardware kit
76157	1	Bottom Bracket, LH
76158	1	Bottom Bracket, RH
80967	1	Lower Bracket, LH
80968	1	Lower Bracket, RH
81520	1	Cable Extension Kit

II. EXPLODED VIEW DIAGRAMS

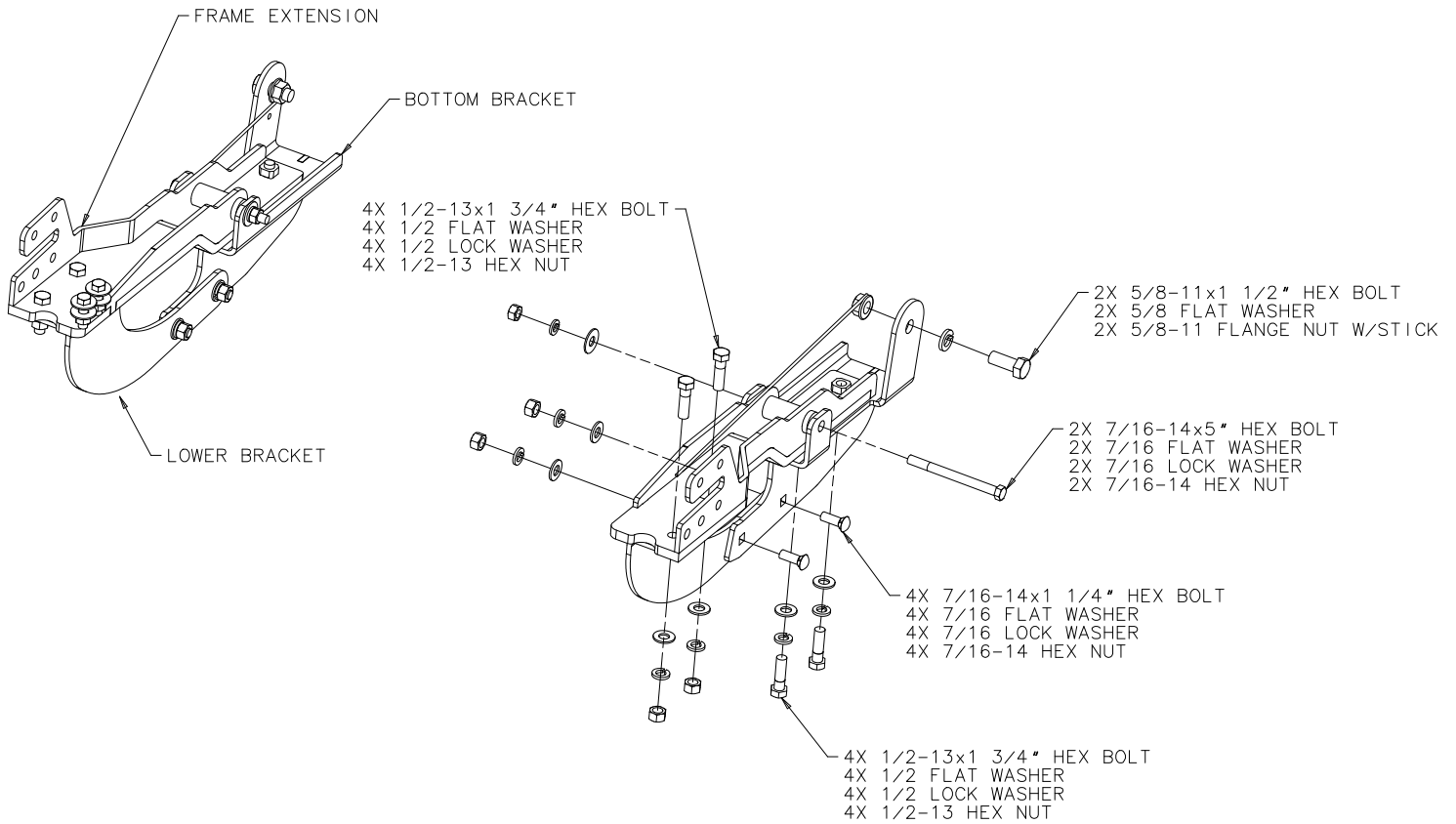

Figure A: Frame Bracket Exploded View

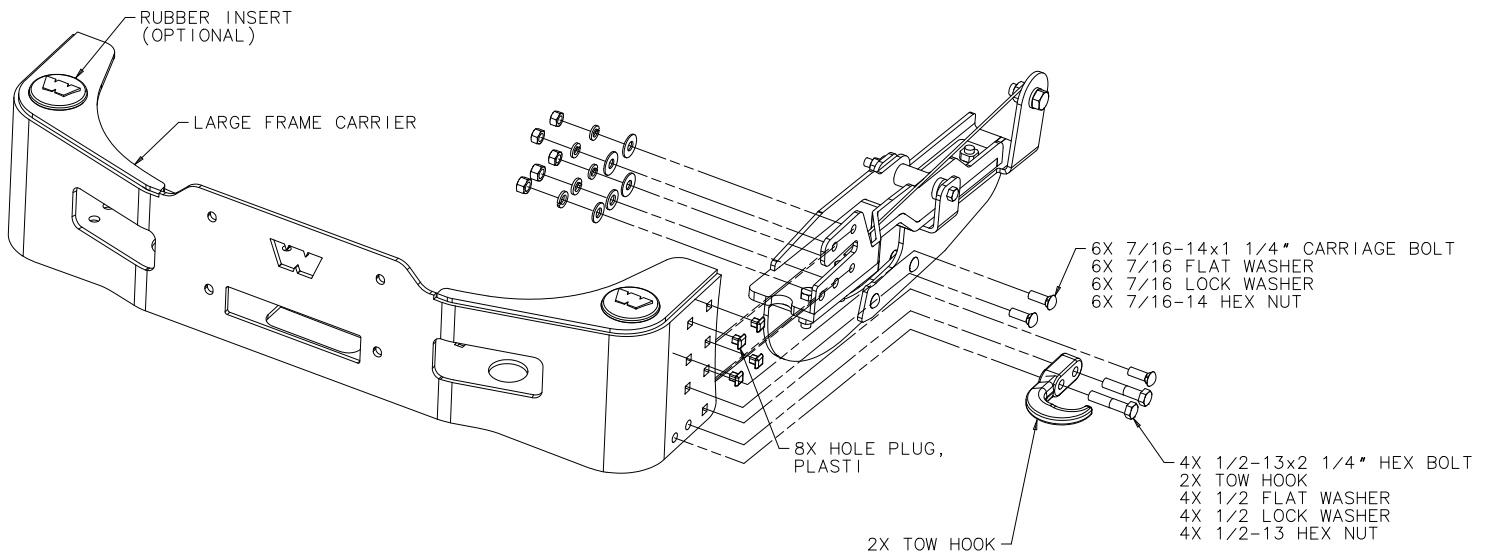

Figure B: 80975 Large Frame Exploded View

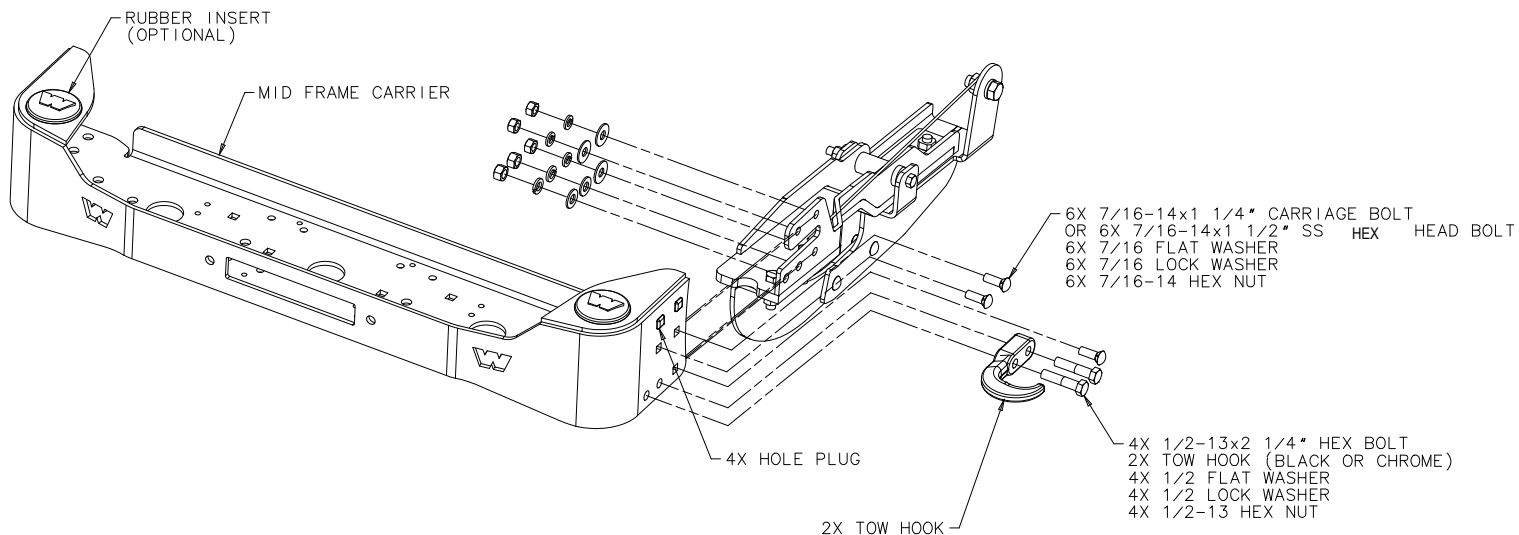

Figure C: Mid Frame Black or Stainless Exploded View

TORQUE SPECIFICATIONS

BOLT SIZE	TORQUE
3/8 inch	30 lb. ft (40.7 N-m)
7/16 inch	50 lb. ft. (67.8 N-m)
1/2 & 5/8 inch	75 lb. ft. (101.7 N-m)

TOOLS REQUIRED

- 15 and 21mm sockets and wrenches**
- 18mm socket**
- 5/8, 11/16, 3/4, 15/16 sockets and/or wrenches**
- 1/4 hex socket wrench (stainless kit)**
- Utility knife or razor saw**

NOTE: Follow the instructions step by step for fastest installation. Do not securely tighten fasteners until directed to do so.

NOTE: Installation of the included power cable extension kit is required for this installation due to the battery location at the rear of the engine compartment.

Remove the tow loops by removing the 12mm (18mm wrench) cross bolt and the 12mm bottom bolt from each. **Figure 1**

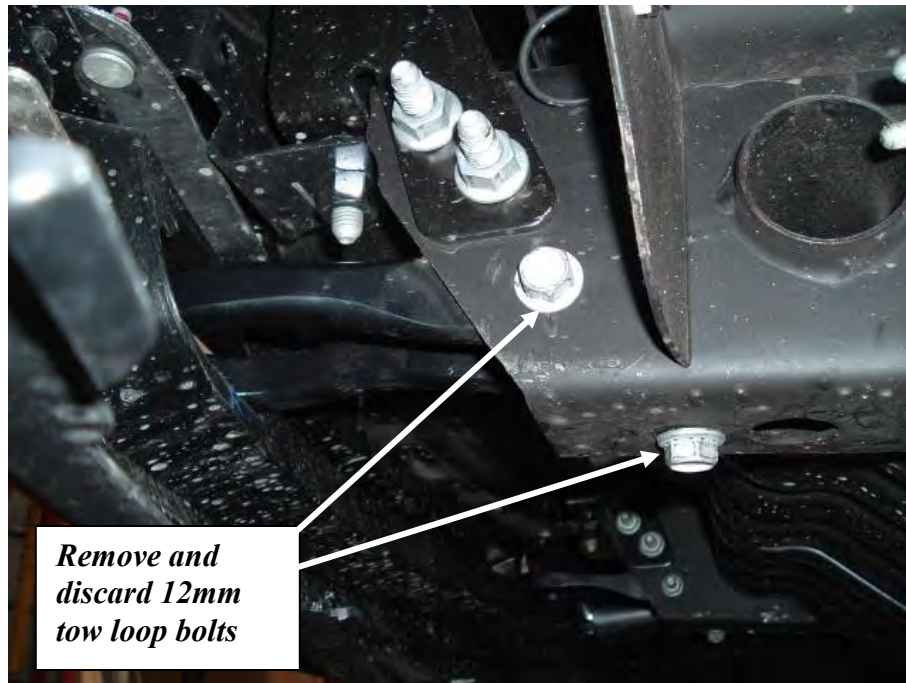

Figure 1 Tow loop bolts – Left side Sierra shown; Silverado similar

Use a knife or saw to trim the tow loop openings in the bumper. See **Figure 2** for Silverado and **Figure 3** for Sierra.

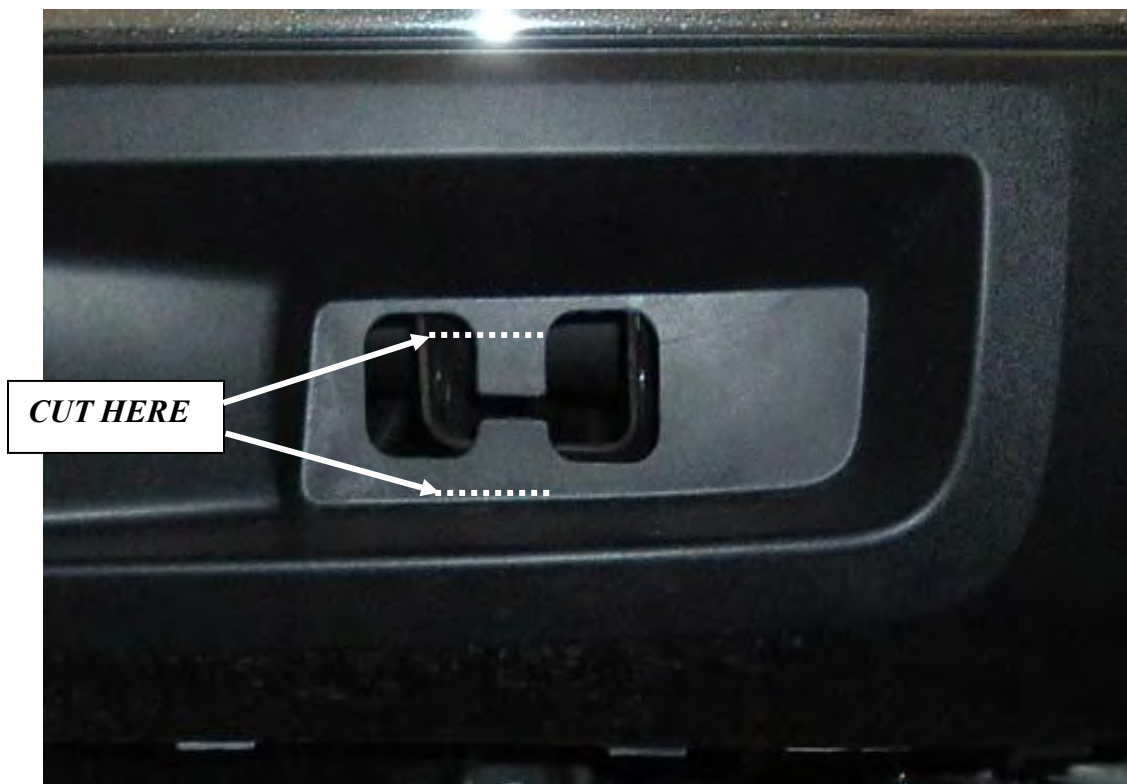

Figure 2 Trim opening for Frame Extension – LH Silverado

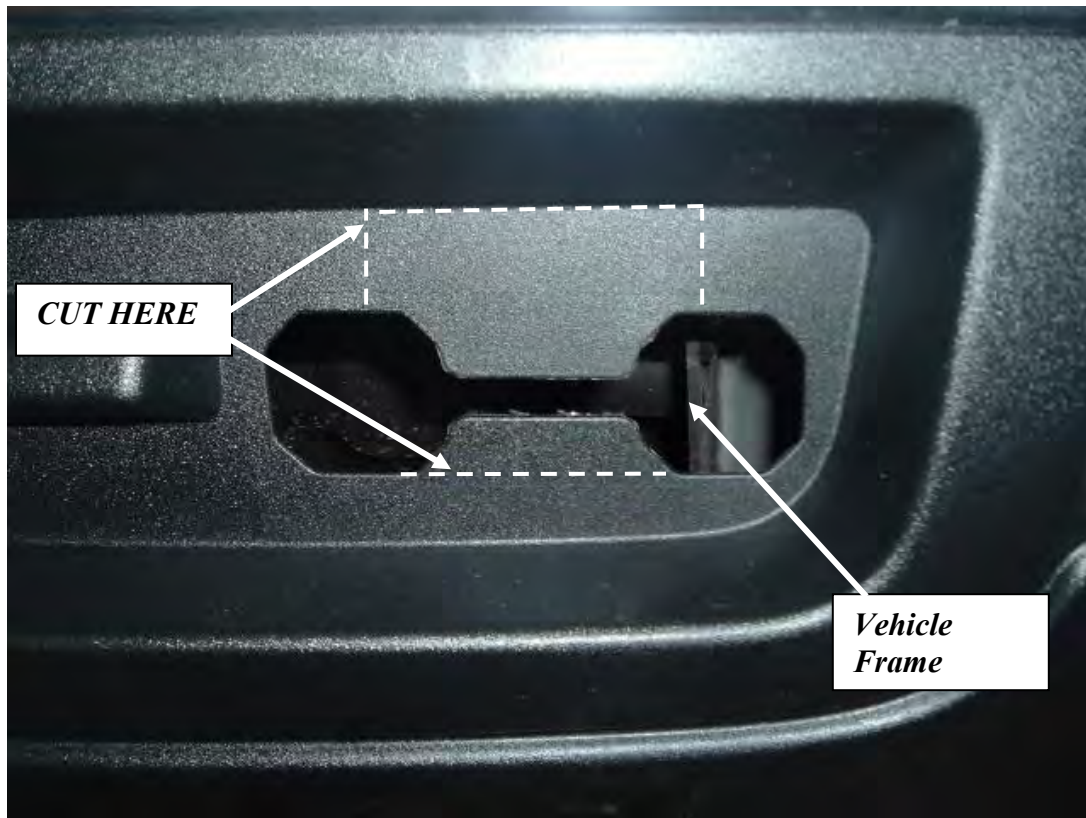

Figure 3 Trim opening for Frame Extension – LH Sierra

Hold one of the Frame Brackets in place and temporarily insert a 7/16 x 5" bolt through the bracket and the frame. Insert a 5/8" "nut with stick" into the end of the frame and align with the diagonal slot in the outside of the frame.

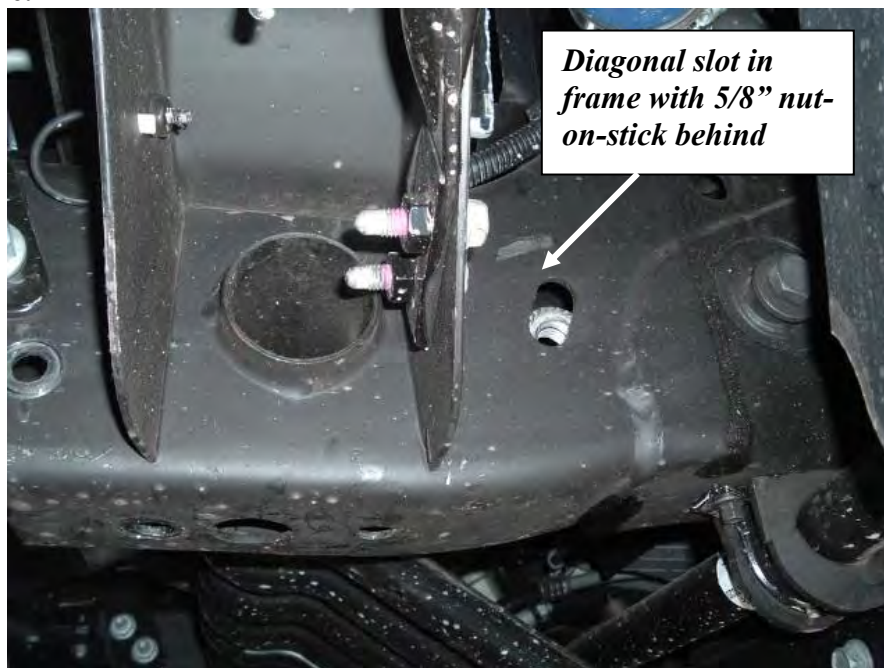

Figure 4 Diagonal slot in frame with 5/8" nut-on-stick shown LH frame shown

Note: it will be necessary to bend the wire attached to the nut to reach the slot. See Figure 4 and 5. Install a 5/8" bolt, lock washer and flat washer through the Frame Bracket and frame into the 5/8" nut. Trim excess wire or bend it out of the way. Do not tighten the bolts yet.

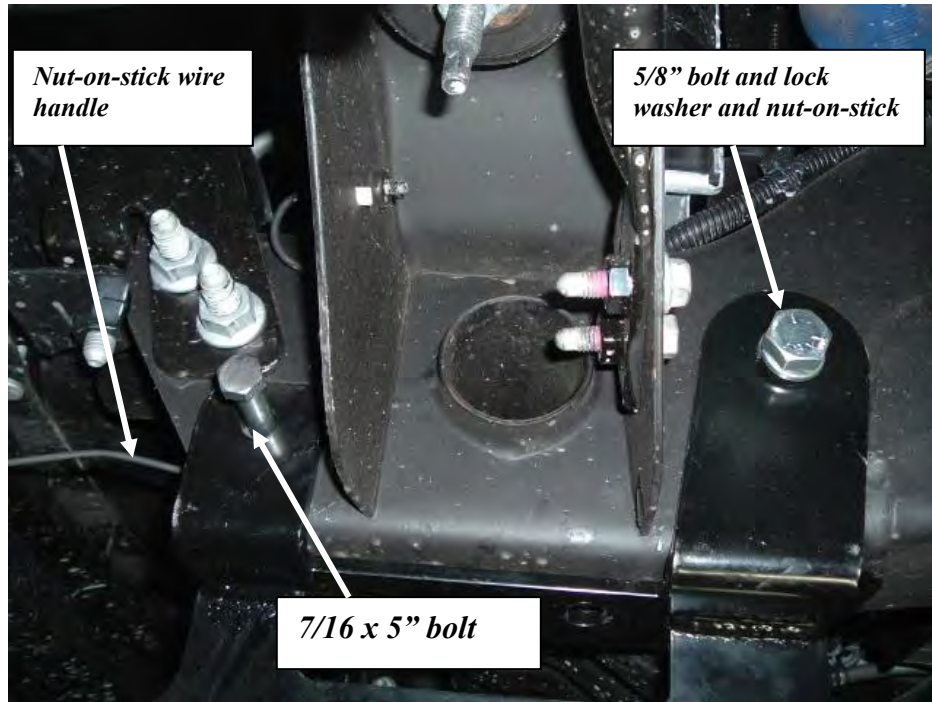

Figure 5 LH Bottom Bracket in place.

Remove the 7/16 x 5" bolts. Insert the LH and RH Frame Extensions into the frame. Reinstall the 7/16 x 5" bolt with flat washers (2ea), lock washers and nuts. Also install two (2) 1/2 x 1 3/4" bolts with lock washers and flat washers through the bottom of each Bottom Bracket and frame, into the nuts welded to the frame extensions. See **Figure 5 and 6**

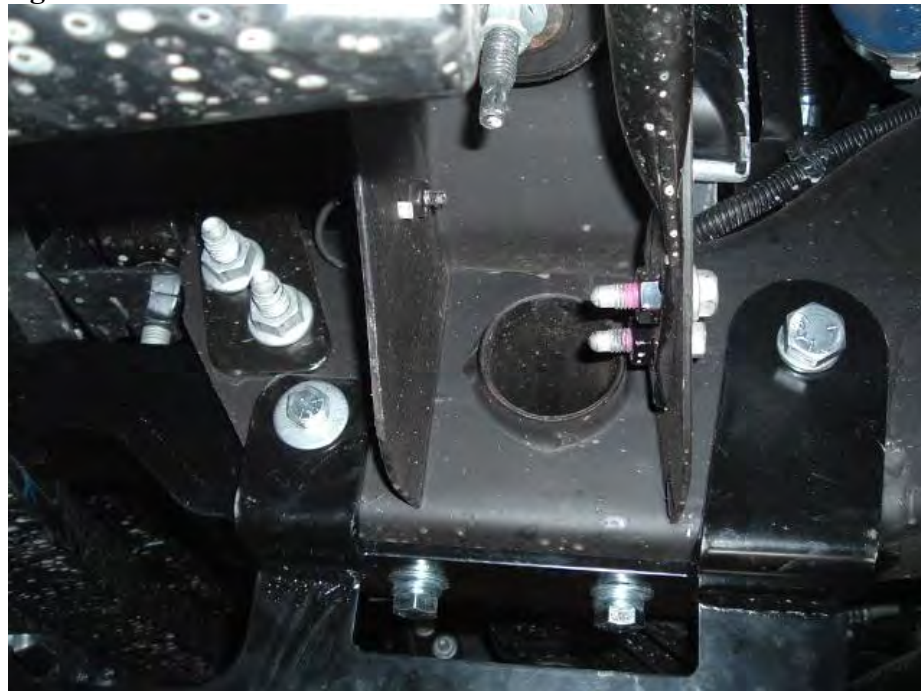

Figure 6 LH Bottom Bracket with hardware

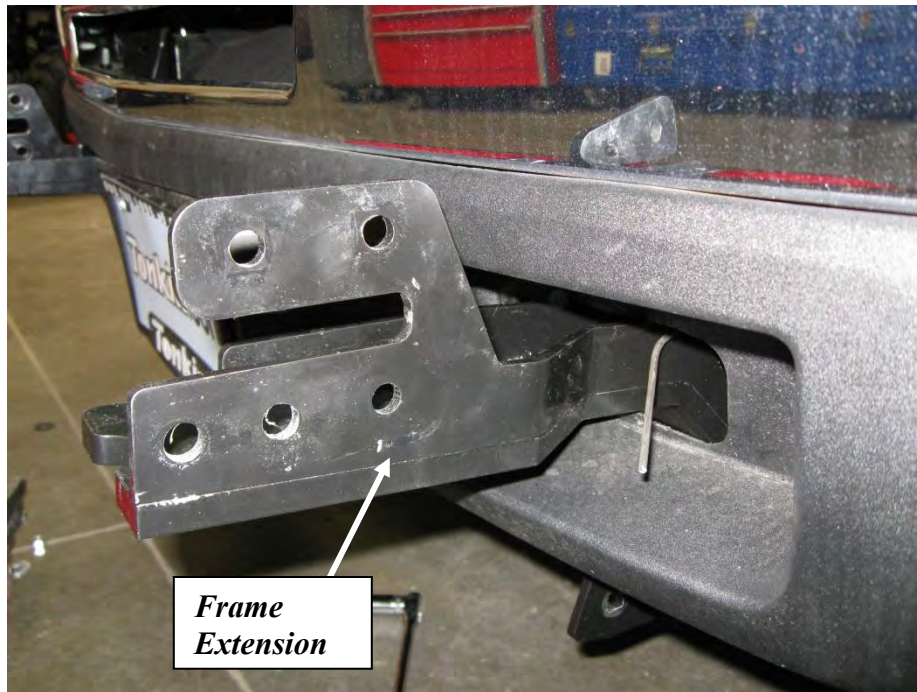

Figure 7 LH Frame Extension Plate in place – Sierra similar

Install the lower bracket to the bottom of the Frame Extension Plates. Use two 7/16 x 1-1/4" carriage bolts, flat washers, lock washers and nuts per lower bracket and two 1/2 x 1 3/4" hex bolts, flat washers, lock washers and nuts for the Frame Extension. Do not tighten yet. **See Figure 8.**

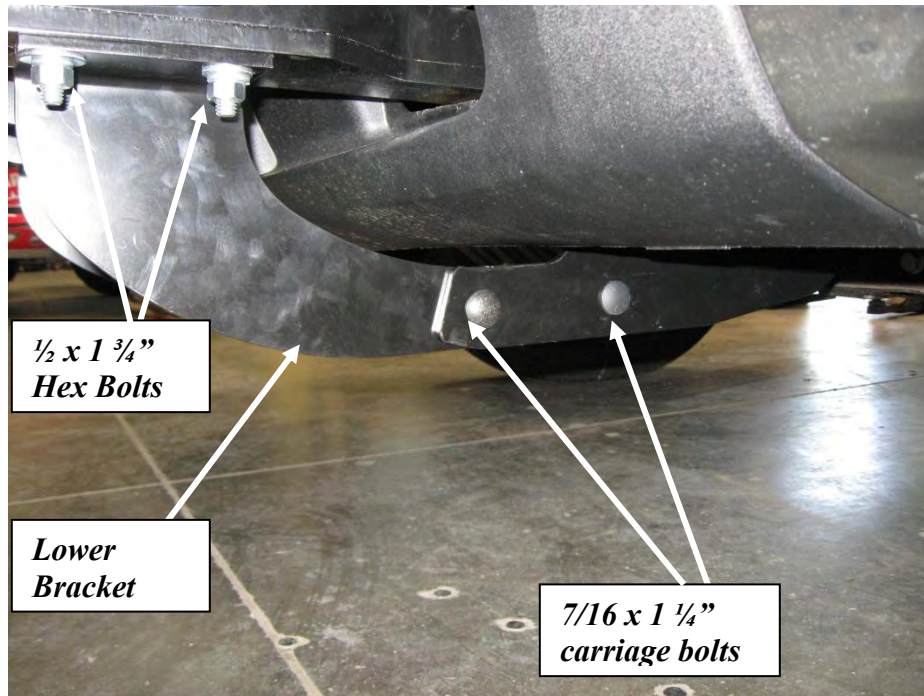

Figure 8 LH Frame Extension and Lower Bracket in place.

Follow the assembly directions provided with the winch carrier for pre-assembly instructions. Once the winch carrier is assembled, install the winch carrier to the outside of the Frame Extension Plates. Use three 7/16 x 1-1/4" carriage bolts, flat washers, lock washers and nuts. If you are installing a stainless kit, use stainless hex head bolts and flat washers (supplied with carrier) in place of carriage bolts. Do not tighten yet. **See Figure 9.**

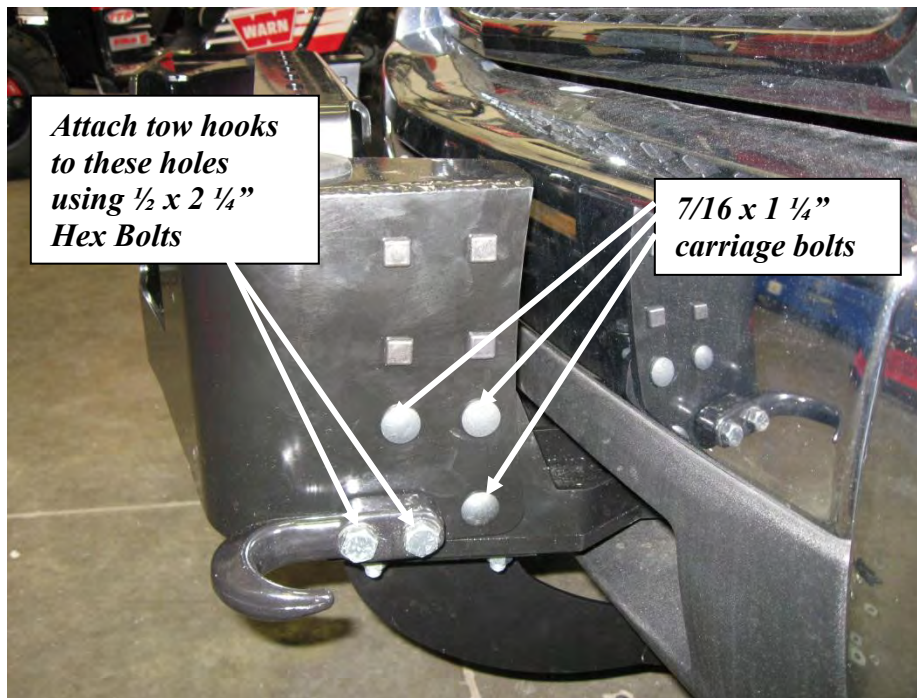

Figure 10 LH Side Member installed

Install the Warn tow hooks to the outside of the winch carrier. Use two (2) 1/2 x 2-1/4 bolts with flat washers, lock washers and nuts per hook. Do not tighten yet.

Begin tightening the hardware starting from the winch carrier working back toward the vehicle until all fasteners are tightened to the torque values specified on page 2.

If you are installing a winch, install it now. Use the hardware and instructions that come with the winch.

Install the cable extension kit to the red and black cables on the winch. The kit extends the cable length and allows the cables to easily reach the battery which is mounted at the rear of the engine compartment. Follow the instructions provided in the cable extension kit.

Verify all fasteners are tightened before operating the winch.

⚠ WARNING
FAILURE TO SECURELY TIGHTEN ALL BOLTS ON THE WINCH PLATE, WINCH, AND FAIRLEAD CAN RESULT IN PRODUCT FAILURE WHICH MAY RESULT IN VEHICLE DAMAGE AND OPERATOR INJURY OR DEATH. DOUBLE CHECK THAT ALL BOLTS ARE SECURELY TIGHTENED PRIOR TO USE.

⚠ WARNING
READ THE VEHICLE'S OPERATOR MANUAL, WINCH OPERATOR MANUAL, AND ALL WARNING LABELS PRIOR TO OPERATION OF WINCH.

⚠ WARNING
PERFORM REGULAR INSPECTIONS ON THE WINCH, WINCH MOUNT, AND RELATED HARDWARE. NEVER OPERATE THE WINCH OR WINCH MOUNT WITH DAMAGED OR MISSING PARTS. FAILURE TO FOLLOW THIS WARNING MAY CAUSE VEHICLE DAMAGE AND OPERATOR INJURY OR DEATH.

Warn Industries

Stainless Steel Truck Accessories

What to expect:

Polished stainless steel combines the beauty of a chrome-like appearance with extreme durability and corrosion resistance. With a minimum amount of care, the appearance will last almost indefinitely. Unlike plating or coatings, there is nothing to peel off or wear away that would allow corrosion underneath.

The actual appearance may not be exactly like new chrome in either the degree of luster or color. There may be fine polishing lines visible up close and small differences between mating parts of an assembly. A grille guard, for instance, may have small differences between the round tubing and the flat plate. The backside of a part may not be as highly polished as the front. However, part of the beauty and appeal of stainless actually lies in the smooth “hand-worked” appearance.

There also is a possibility that small rust spots can appear on stainless products. They are usually due to minor iron contamination on the surface as a result of normal manufacturing and handling processes. This minor rust, if it occurs at all, is easy to remove and will not tend to spread.

Recommended care:

Regular washing with fresh water and mild car wash detergents followed by rinsing and drying with a soft towel is the best minimum care. Beyond that, any cleaner/wax recommended for automotive finishes will work well to remove minor stains and scuffs, enhance the shine and provide protection. Always use clean soft cotton cloths. In most cases, this will be all that is required for many years. For more serious blemishes or a rust spot, use a cream metal polish recommended for stainless, aluminum, etc. Try to rub in the direction of the original polishing lines.

Ultimately, any stainless part can be restored to a brilliant shine with power buffing processes.

Caution:

Do not use steel wool or any type of metal scraper. Do not use “Scotch Brite” pads or abrasive powdered cleaners. Do not try to clean with muriatic acid or any other acid.

Stainless Fasteners

Stainless steel fasteners are included in many of the stainless kits. These fasteners provide similar corrosion resistance and appearance as the rest of the kit. However, stainless fasteners are prone to galling when installed in similar stainless material. It is a good idea to apply a small amount of anti-seize compound to the threads when installing them. Care should also be taken when tightening the fasteners to prevent rounding or deforming the corners of the bolts. Make sure the wrenches are the correct size and fit properly. In the case of socket heads, the wrench should have sharp, un-worn edges. With a few precautions during assembly the products should provide years of service.