



INSTALLATION INSTRUCTIONS

Trans4mer Gen II Mount System For 2009 -current Dodge Ram 1500 Bracket Kit 90135

Your safety, and the safety of others, is very important. To help you make informed decisions about safety, we have provided installation and operating instructions and other information on labels and in this guide. This information alerts you to potential hazards that could hurt you or others. It is not possible to warn you about all potential hazards associated with this product, you must use your own good judgment.

CARELESS INSTALLATION AND OPERATION CAN RESULT IN SERIOUS INJURY OR EQUIPMENT DAMAGE. READ AND UNDERSTAND ALL SAFETY PRECAUTIONS AND OPERATING INSTRUCTIONS BEFORE INSTALLING AND OPERATING THIS PRODUCT.

This guide identifies potential hazards and has important safety messages that help you and others avoid personal injury or death. **WARNING** and **CAUTION** are signal words that identify the level of hazard. These signal words mean:

WARNING signals a hazard that could cause serious injury or death, if you do not follow recommendations.

CAUTION signals a hazard that may cause minor to moderate injury, if you do not follow recommendations.

This guide uses **NOTICE** to call attention to important mechanical information, and **Note**: to emphasize general information worthy of special attention.

WARNING

Failure to observe these instructions could lead to severe injury or death.

- Always** use extreme caution when drilling on any vehicle. Make sure that all fuel lines, brake lines, electrical wires, and other objects are not punctured or damaged when/if drilling on the vehicle. Thoroughly inspect the area to be drilled (on both sides of material) prior to drilling, and relocate any objects that may be damaged. Failure to inspect the area to be drilled may result in vehicle damage, electrical shock, fire or personal injury.
- Always** wear safety glasses when installing this kit. A drilling operation will cause flying metal chips. Flying chips can cause eye injury.
- Always** use extreme caution when cutting and trimming during fitting.
- Always** remove jewelry and wear eye protection.
- Always** use appropriate and adequate care in lifting components into place.
- Always** insure components will remain secure during installation and operation.
- Always** tighten all nuts and bolts securely, per the installation instructions.

WARNING

Failure to observe these instructions could lead to severe injury or death.

- Always** securely tighten all bolts on the winch plate, winch, and fairlead. Loose bolts can result in product failure which may result in vehicle damage and operator injury or death.
- Always** double check that all bolts are securely tightened prior to use.

This WARN Trans4mer Gen II system can be customized to give your vehicle a wide variety of looks, front-end protection and winch mounting capability. The system starts with this winch carrier that attaches to the truck's frame with brackets designed to handle up to a 12,000 lb winch. This provides a mounting location for a Warn winch. It is durable and good looking as a stand-alone winch mount, but can be easily upgraded with some great options! You can first add a center Grille Guard Tube that provides a mounting location for other accessories. You can add a light bar that adds even more protection and includes tabs for mounting auxiliary lights. You may also add a receiver bracket that will handle the Warn multi-mount winch system. Finally, head lamp guards that protect the headlights and front corners of the vehicle can be easily added to any of the options above.

Before You Begin

- Read and understand these Installation Instructions.
- Refer to the Parts Lists below for your specific mounting system to become familiar with the components and hardware in this kit.

I. PARTS LIST FOR 90135 Dodge Ram 1500 Mid Frame Bracket Kit

<u>Part Number.</u>	<u>Qty</u>	<u>Description</u>
80786	1	Frame Extension, RH
80785	1	Frame Extension, LH
80713	1	Frame Re-Enforcing Bracket, RH
80787	1	Frame Re-Enforcing Bracket, LH
81216	1	Lower Bracket, RH
81217	4	Lower Bracket, LH
81221	1	Hardware Kit

II. EXPLODED VIEW DIAGRAM

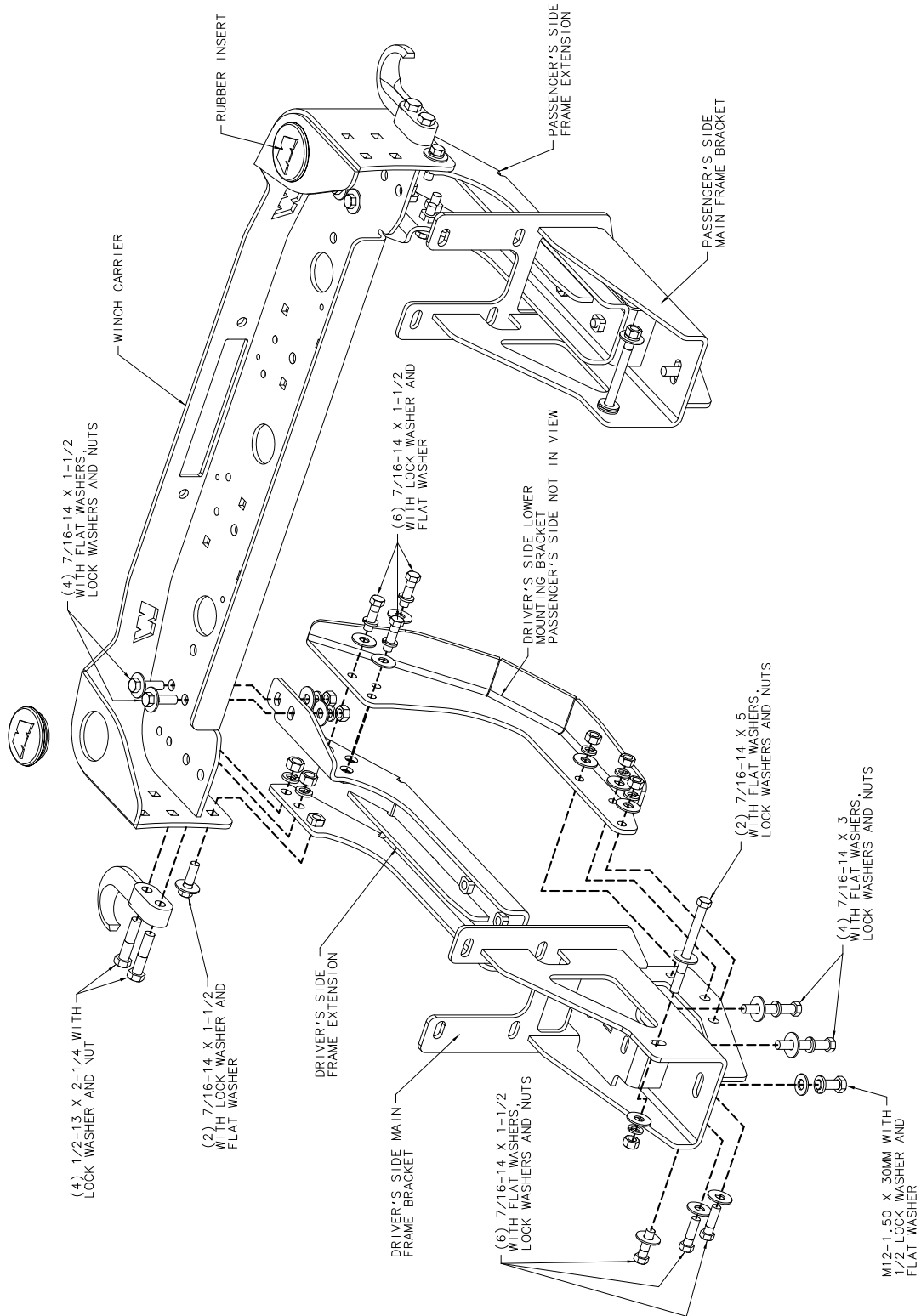

Figure A: 2009 Dodge Ram 1500 Mid Frame Exploded View

NOTE: Follow the instructions step by step for fastest installation. Do not securely tighten fasteners until directed to do so.

III. TORQUE SPECIFICATIONS

BOLT SIZE	TORQUE
12mm	50 lb. ft (67.8 N-m)
7/16 inch	50 lb. ft. (67.8 N-m)
½ inch	75 lb. ft. (101.7 N-m)

V. VEHICLE PREPARATION

1. Remove the front tow hooks if so equipped. Loosen but do not remove the bumper mounting nuts.



Figure B

2. On Sport models, it is necessary to trim part of the plastic bumper mount. **See Figure C and D.**

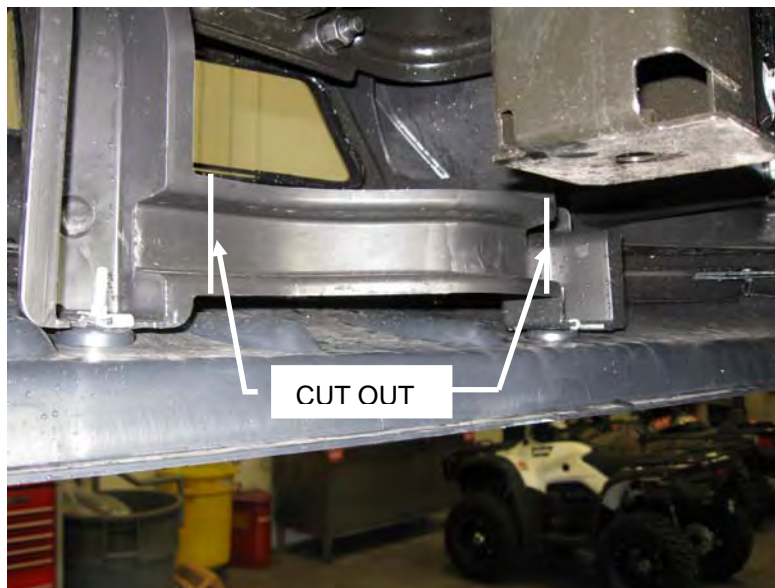

Figure C, Sport models only.

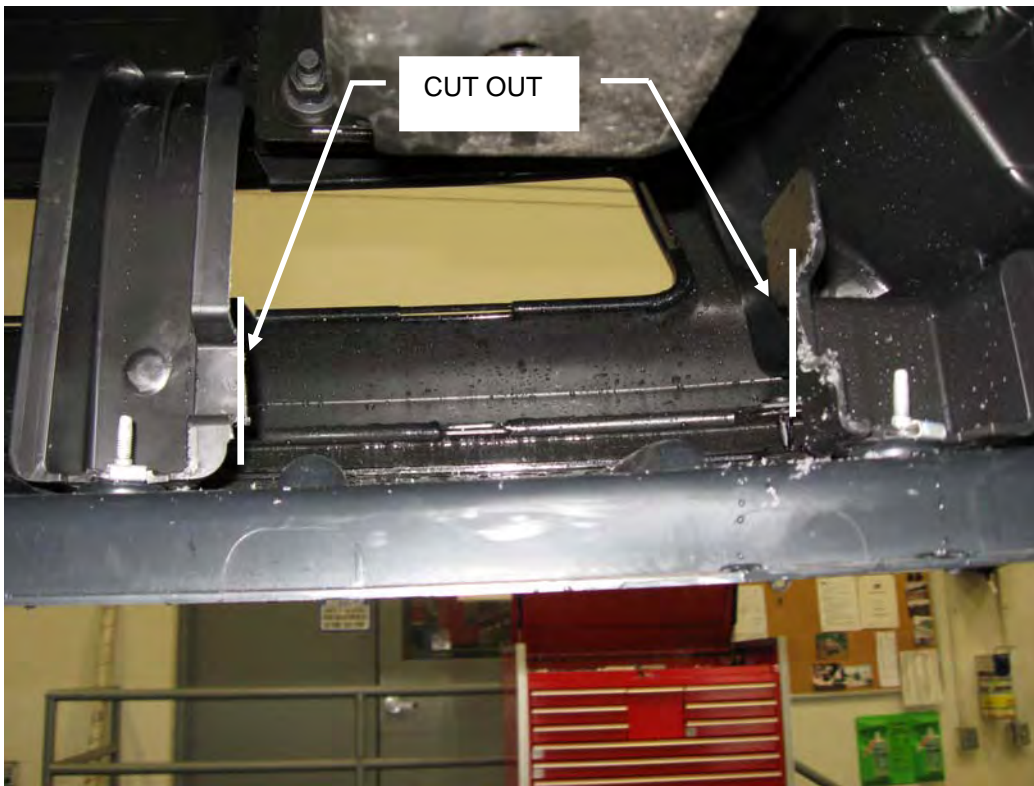

Figure D, Sport models only.

3. If your vehicle does not have factory tow hooks, remove the front plastic insert in the center of the bumper and prepare to trim. **See Figure E.**

NOTE: Two-piece bumper inserts for 2013 trucks, will not re-used after removal.

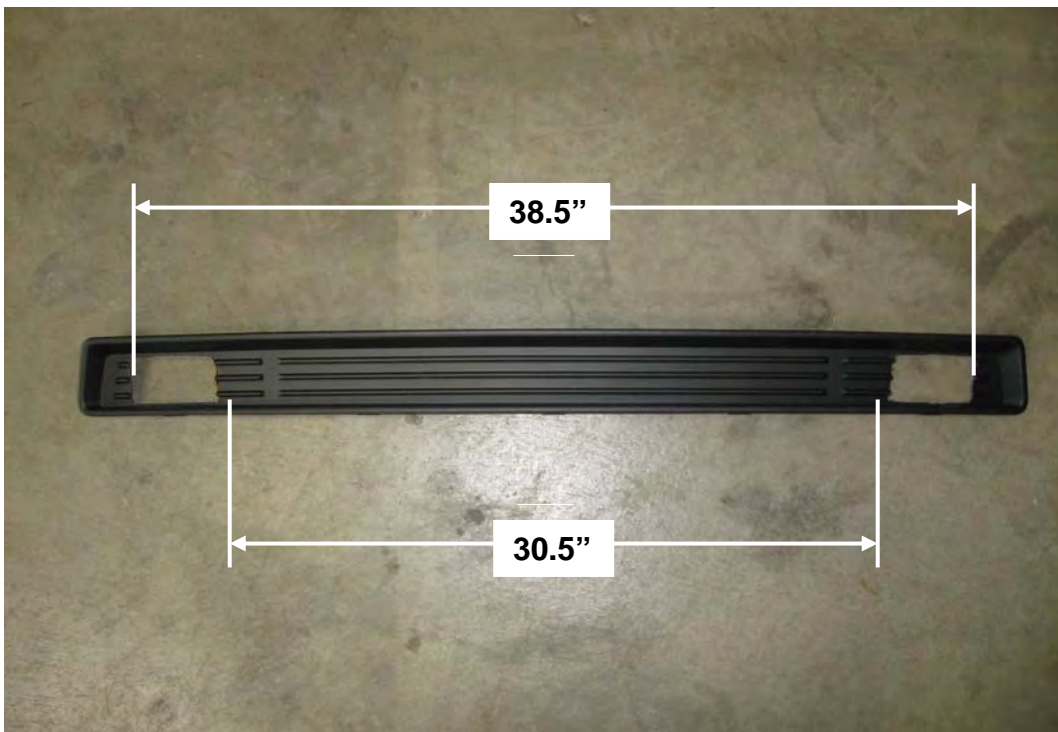

Figure E, Vehicles without factory tow hooks only.

Trim a rectangular hole into each side of the plastic insert. The easiest way to accomplish this with minimal tools is to draw out the rectangle prior to cutting. The rectangle should be approximately 4" wide by 2.5" tall. Once you have drawn the rectangle, drill a 1/2" hole inside of each corner. Then use a hack saw blade, cutting wheel or utility knife to cut out the rest of the rectangle. **See Figure F.**

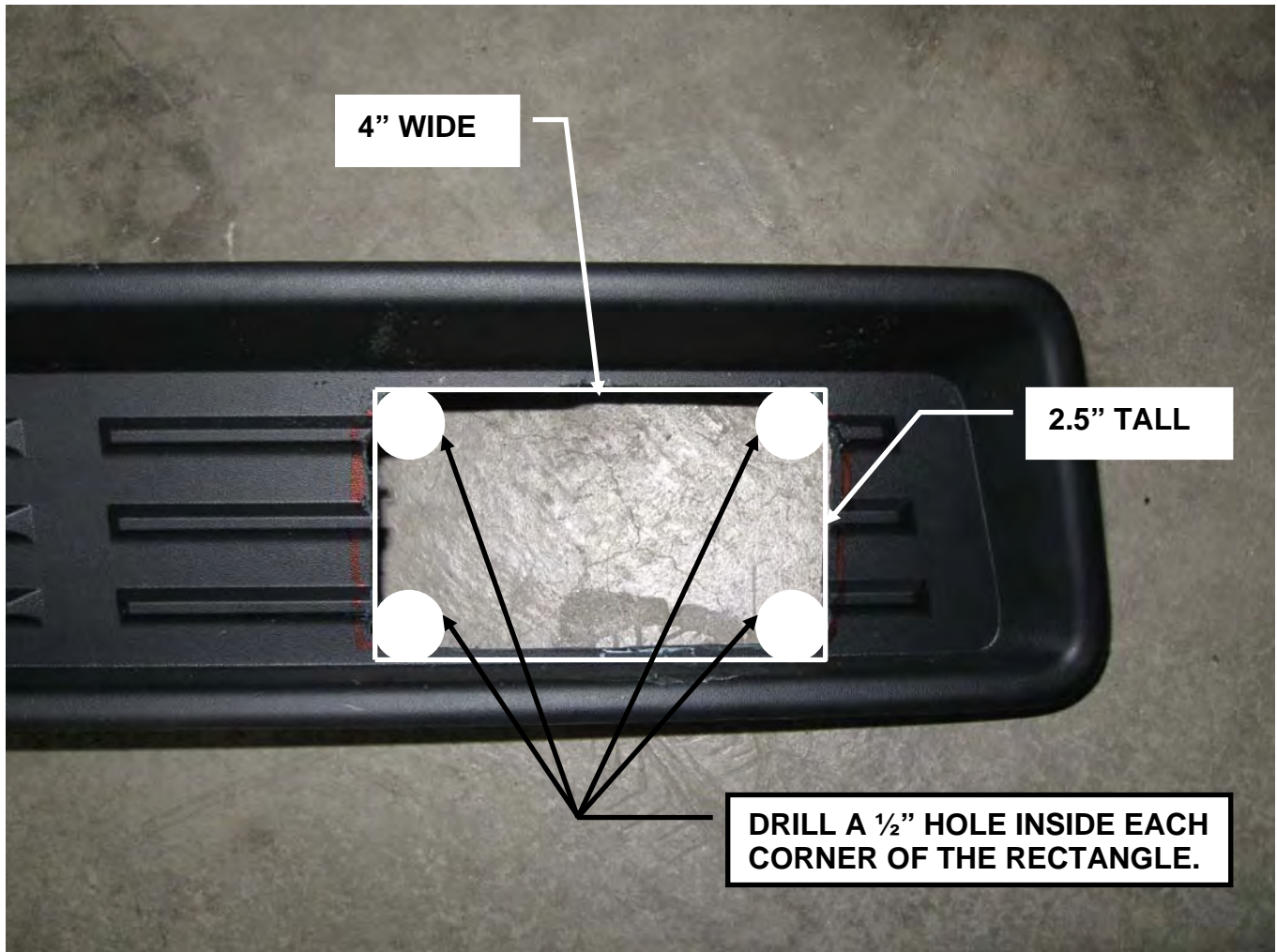

Figure F, Cut access holes for vehicles without factory tow hooks only.

⚠ WARNING



Drilling, Grinding and Cutting operations can cause flying chips. **WEAR SAFETY GOGGLES.**
Flying chips can cause eye injury.

4. Install the plastic insert back into the bumper.
5. It is necessary to trim a slot 1" wide into the plastic air dam located on the bottom of the bumper for each frame bracket. The outside to outside measurement of the two slots is 32". The inside to inside measurement between the slots is 30". Mark out the slots before trimming and be sure that you are centered on the air dam. There are four different air dams between the various trim packages. The slots will always be the same measurements but it will vary as to how far forward the slot will be cut in the air dam. Begin by cutting only a small amount forward. You will cut more as you begin installing the frame brackets. **See Figures G and H.**

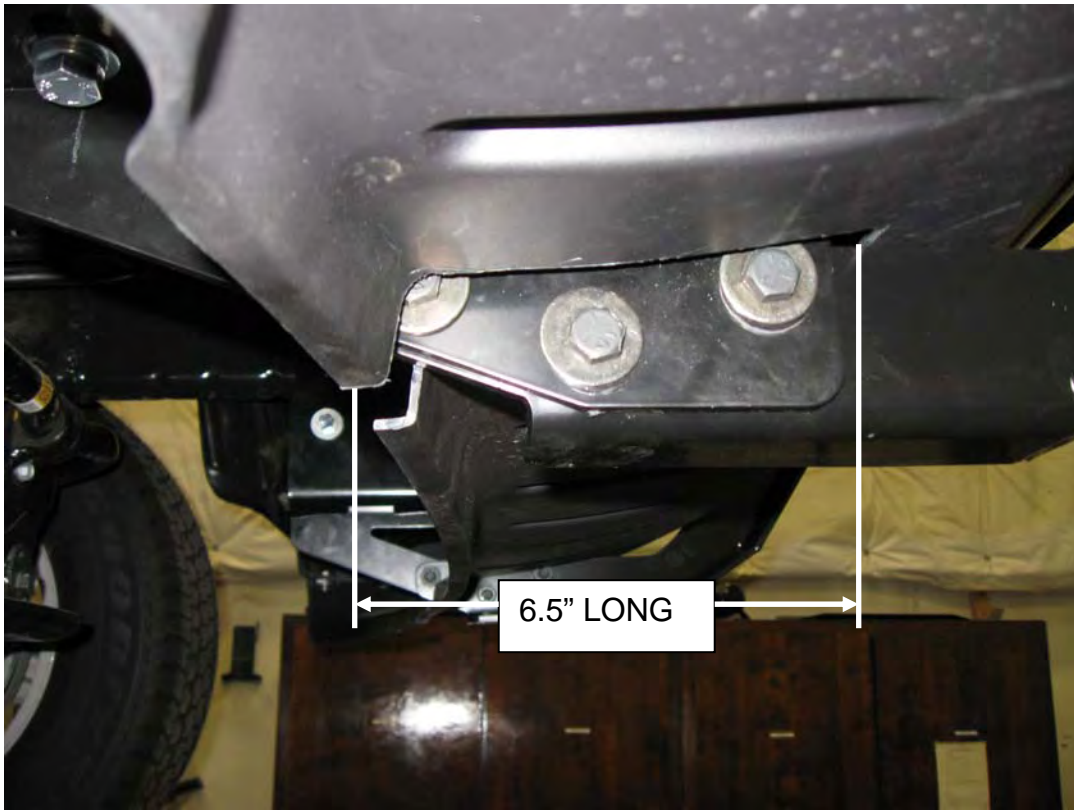

Figure G, Cut 1" wide access slot in factory air dam.



Figure H, Cut 1" wide access slots into factory air dam, 32" outside to outside of slot.

⚠ WARNING



Drilling, Grinding and Cutting operations can cause flying chips. **WEAR SAFETY GOGGLES.**
Flying chips can cause eye injury.

VI. INSTALLATION

1. Install the frame bracket on the passenger's side frame by first removing the 2-3 factory bumper mounting nuts. Slip the frame bracket onto the bumper mounting studs. Some vehicles have two and some have three bumper mounting location per side. **See figure 1 and 2.**

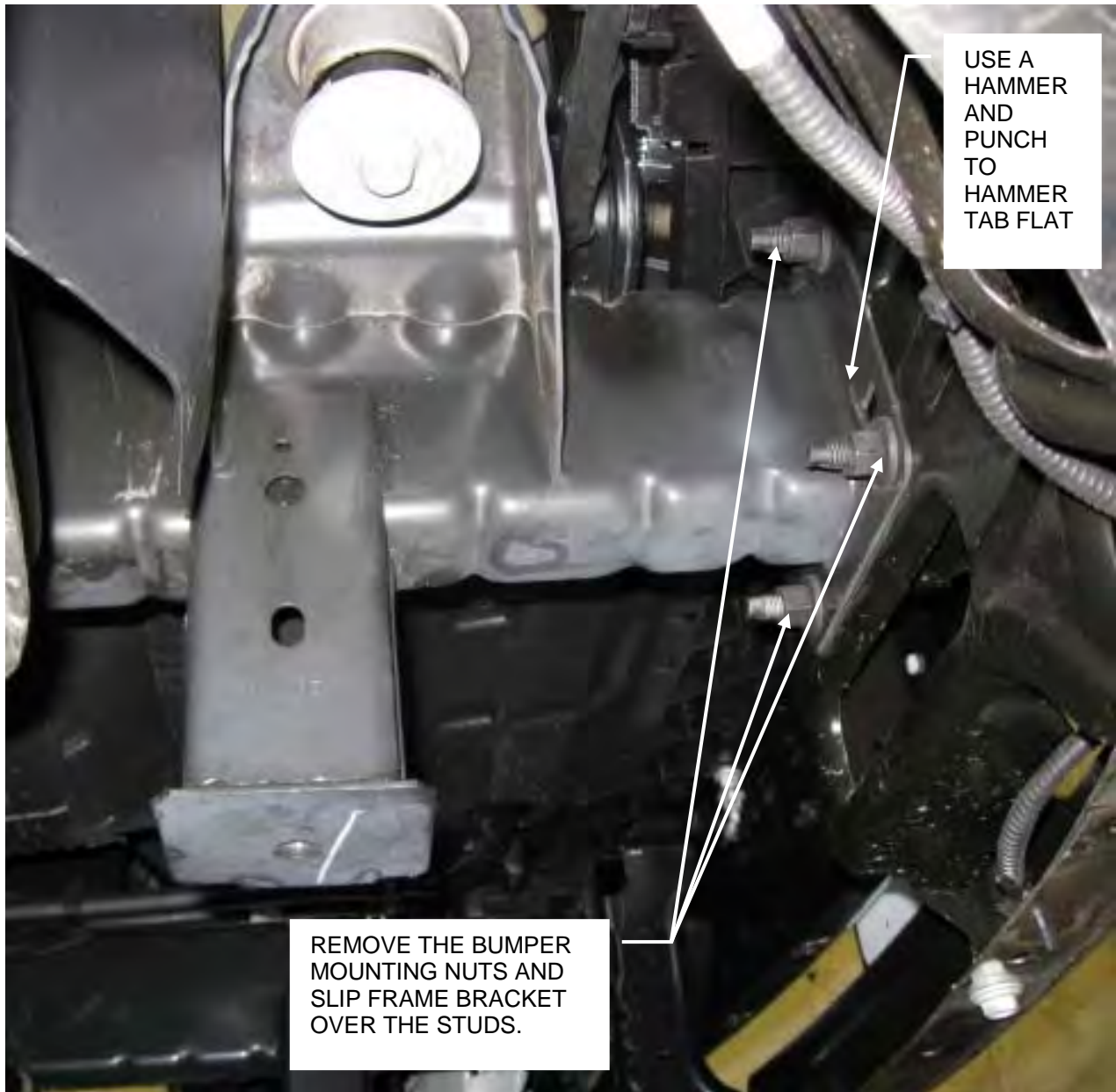

Figure 1: Placement of the Frame Bracket (Passenger Side)

As you are installing the frame brackets it will be necessary to trim the bumper air dam to allow the bracket to fit onto the bumper mounting studs. **Refer to Figure G and H.**

Once you have trimmed the air dam and placed the passenger's side bracket onto the bumper mounting studs, install the factory nuts onto the stud. Do not tighten at this time. All models except sport models can install a 7/16" x 1-1/2" long bolt through the upper inside mounting hole that did not have a factory bumper mounting stud. If you are installing on a Sport Model truck, this bolt can not be installed and is not necessary for winch pulling integrity.

Repeat this step for the driver's side of the vehicle.

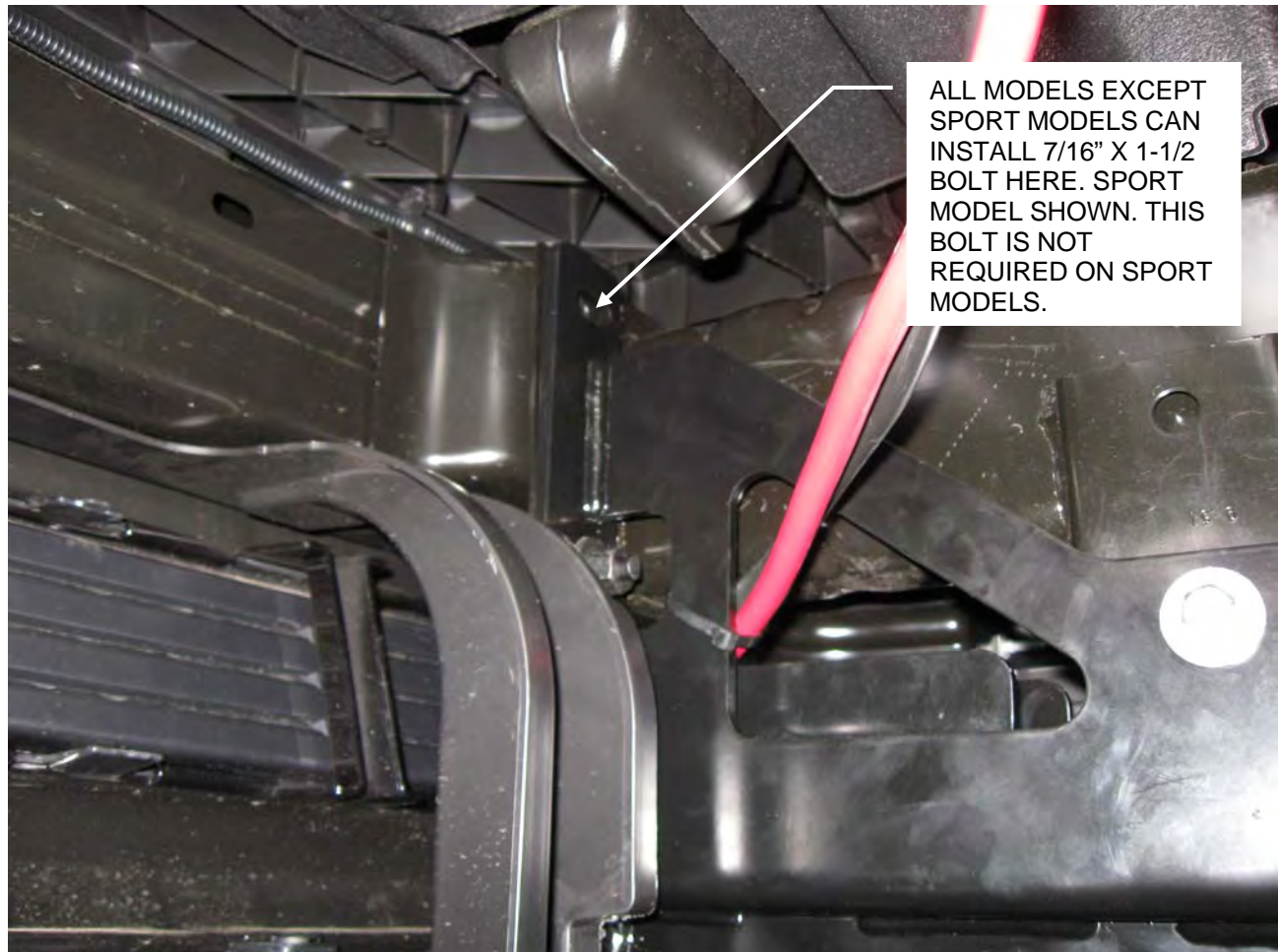

Figure 2: Placement of the Frame Bracket (Passenger Side)

⚠ WARNING



Drilling, Grinding and Cutting operations can cause flying chips. **WEAR SAFETY GOGGLES.**

Flying chips can cause eye injury.

2. Install the supplied M12 x 30mm bolt with $\frac{1}{2}$ " lock washer and $\frac{1}{2}$ " flat washer through the bottom back slotted hole in the frame bracket and into the factory threaded hole. See **Figure 3**. Do not tighten any fasteners until instructed to do so.



Figure 3: Installation of bottom frame bolt, M12 x 30mm

3. Install the $\frac{7}{16}$ " x 5" long bolt with flat washer through the frame bracket. It will be necessary to place 1 to 3 $\frac{1}{2}$ " washers between the frame bracket and the frame tube so that there is no gap between them. Push the bolt through the frame bracket, washers and completely through the frame tube and then install a $\frac{7}{16}$ " flat washer, lock washer and nut onto the bolt. Repeat this for the opposite side of the vehicle. See Figure 4. Do not tighten any fasteners until instructed to do so.

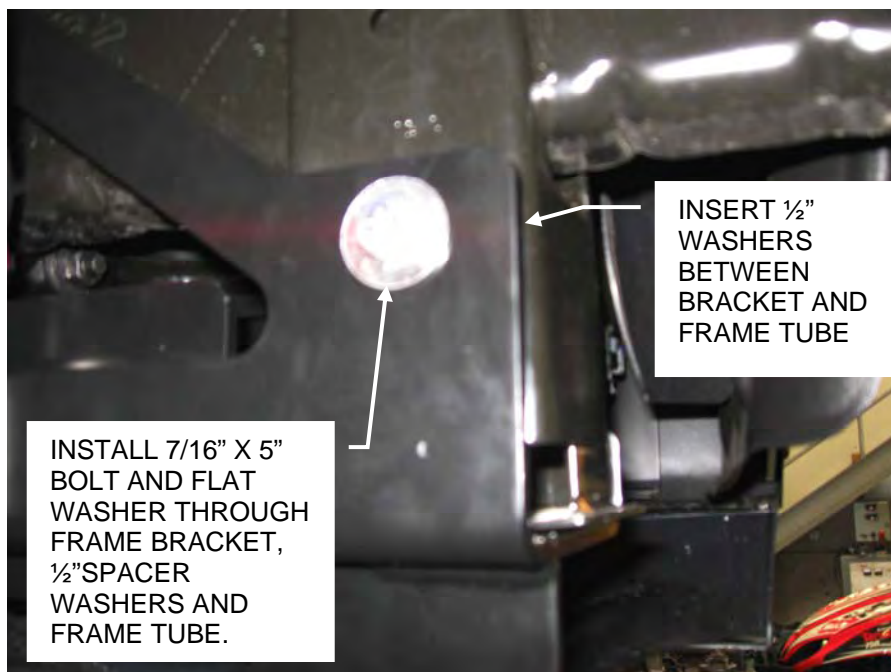

Figure 4: Installation of Upper Rear frame bolt, 7/16" x 5"

4. Install the frame extension brackets through the front access hole that you cut in the bumper or where your tow hooks went through the bumper. Insert a 7/16" x 3" bolt and washer through the main frame brackets and thread the bolts into the weld nuts on the frame extensions. There are two 7/16" x 3" bolts per side of the vehicle. See **Figures 5 and 6**. Do not tighten any fasteners until instructed to do so.



Figure 5: Installation of Frame Extension Bracket, Driver's Side Shown

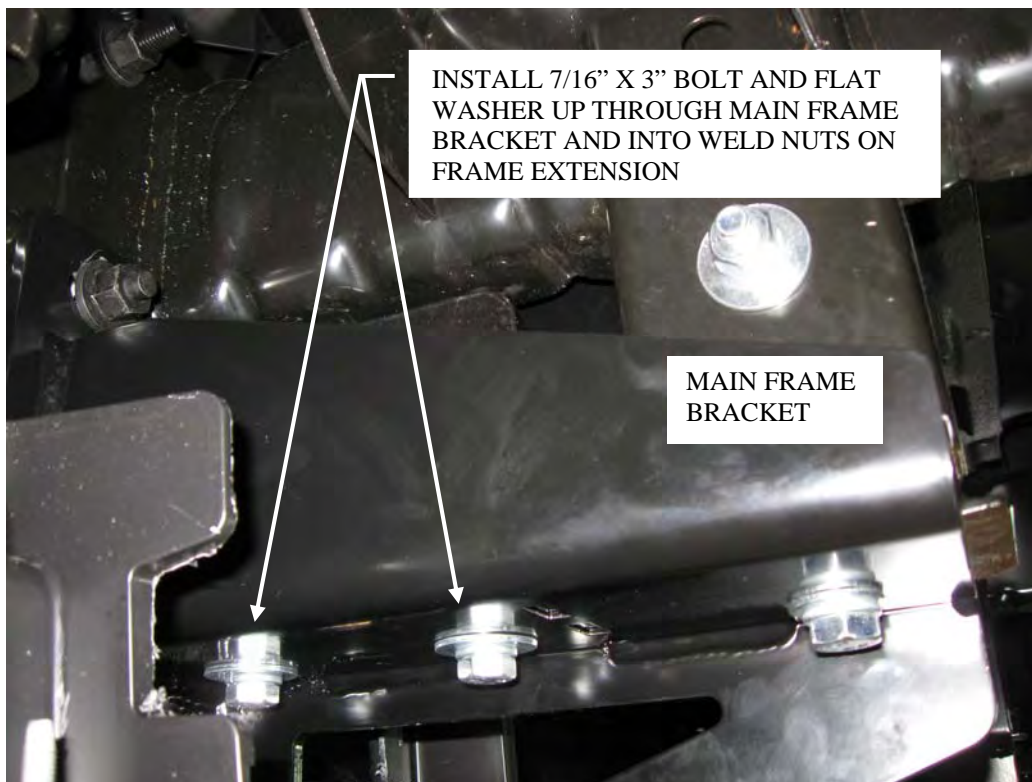

Figure 6: Installation of Frame Extension Bracket, 7/16" x 3" bolts

5. Install the winch carrier to the frame extensions. Insert two $\frac{1}{2}$ " x 2-1/4" long bolts through a tow hook, the winch carrier and then the frame extension. Install a $\frac{1}{2}$ " lock washer and nut onto each bolt. Install a $\frac{7}{16}$ " x 1-1/2" long bolt, lock washer and flat washer (use stainless bolts and flat washers supplied with carrier kit in place of carriage bolt for stainless kits) through the winch carrier and into the weld nut on the frame extension. Repeat this for the opposite side of the vehicle. **See Figure 7.**

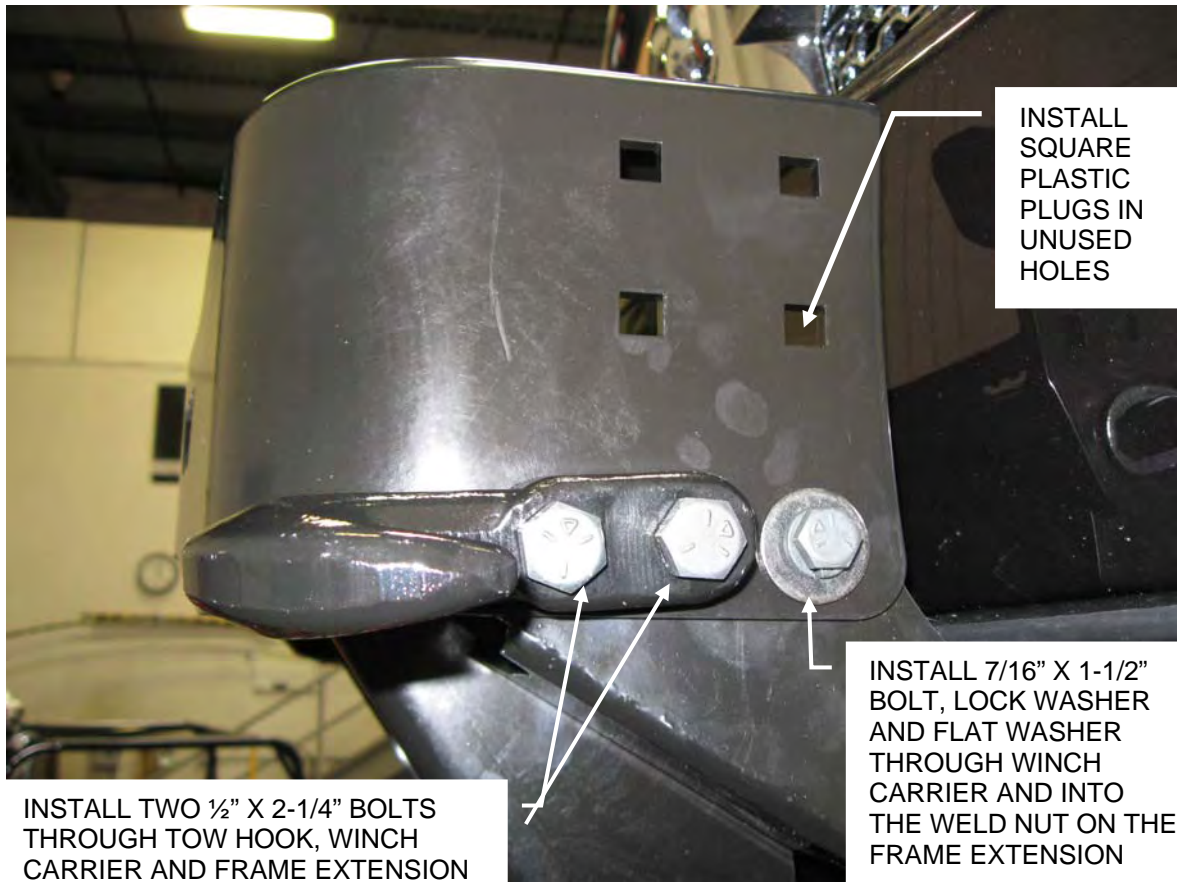

Figure 7: Installation of Winch Carrier, Driver's Side Shown

6. Install two $\frac{7}{16}$ " x 1-1/2" bolts and flat washers (use stainless bolts and flat washers supplied with carrier kit for stainless kits) through the winch carrier and into the frame extensions. Repeat this for the opposite side of the vehicle. **See Figure 8.**



INSTALL 7/16" X 1-1/2" BOLT AND WASHER (USE STAINLESS BOLT AND WASHER FOR STAINLESS KITS) THROUGH WINCH CARRIER AND FRAME EXTENSION. INSTALL A 7/16" FLAT WASHER, LOCK WASHER AND NUT ONTO EACH BOLT.

Figure 8: Winch Carrier to Frame Extension bolts

7. Install the lower frame brackets. Use **Figure 9** to determine the location of the left and right lower frame brackets. Install the lower frame bracket to the main frame bracket using the 7/16" x 1-1/2" bolts. Install a bolt and washer through each of the 3 holes in the main frame bracket and through the lower frame bracket. Install a 7/16" washer, lock washer and nut onto each bolt. Install a 7/16" x 1-1/2" bolt, lock washer and flat washer through the lower frame bracket and into the each of the three weld nuts on the frame extension.



Figure 9: Driver's Side View. Lower Frame Bracket Installation

8. If a Warn winch is being installed at this time, install the winch per the installation instructions that came with the winch.
9. Tighten all fasteners to their specified torque. Start by tightening the factory bumper nuts and then the main frame brackets. Then tighten the frame extension hardware, winch carrier hardware and lower mounting bracket hardware. Double check that all mounting hardware for the frame brackets, factory bumper and winch carrier are at their proper torque or the factory torque.

10. If you are not installing a Warn Grille Guard Tube, install the 2 rubber plugs with the “W” into the large holes in the top of the winch carrier. See the exploded views in the beginning of this manual for location. Gently push the rubber plugs into place.



Figure 11: Finished kit (Winch Not Included)

⚠ WARNING

READ THE VEHICLE'S OPERATOR MANUAL, WINCH OPERATOR MANUAL, AND ALL WARNING LABELS PRIOR TO OPERATION OF WINCH.

⚠ WARNING

FAILURE TO SECURELY TIGHTEN ALL BOLTS ON THE WINCH PLATE, WINCH, AND FAIRLEAD CAN RESULT IN PRODUCT FAILURE WHICH MAY RESULT IN VEHICLE DAMAGE AND OPERATOR INJURY OR DEATH. DOUBLE CHECK THAT ALL BOLTS ARE SECURELY TIGHTENED PRIOR TO USE.

Warn Industries Stainless Steel Truck Accessories

What to expect:

Polished stainless steel combines the beauty of a chrome-like appearance with extreme durability and corrosion resistance. With a minimum amount of care, the appearance will last almost indefinitely. Unlike plating or coatings, there is nothing to peel off or wear away that would allow corrosion underneath.

The actual appearance may not be exactly like new chrome in either the degree of luster or color. There may be fine polishing lines visible up close and small differences between mating parts of an assembly. A grille guard, for instance, may have small differences between the round tubing and the flat plate. The backside of a part may not be as highly polished as the front. However, part of the beauty and appeal of stainless actually lies in the smooth “hand-worked” appearance.

There also is a possibility that small rust spots can appear on stainless products. They are usually due to minor iron contamination on the surface as a result of normal manufacturing and handling processes. This minor rust, if it occurs at all, is easy to remove and will not tend to spread.

Recommended care:

Regular washing with fresh water and mild car wash detergents followed by rinsing and drying with a soft towel is the best minimum care. Beyond that, any cleaner/wax recommended for automotive finishes will work well to remove minor stains and scuffs, enhance the shine and provide protection. Always use clean soft cotton cloths. In most cases, this will be all that is required for many years. For more serious blemishes or a rust spot, use a cream metal polish recommended for stainless, aluminum, etc. Try to rub in the direction of the original polishing lines.

Ultimately, any stainless part can be restored to a brilliant shine with power buffing processes.

Caution:

Do not use steel wool or any type of metal scraper. Do not use “Scotch Brite” pads or abrasive powdered cleaners. Do not try to clean with muriatic acid or any other acid.

Stainless Fasteners

Stainless steel fasteners are included in many of the stainless kits. These fasteners provide similar corrosion resistance and appearance as the rest of the kit. However, stainless fasteners are prone to galling when installed in similar stainless material. It is a good idea to apply a small amount of anti-seize compound to the threads when installing them. Care should also be taken when tightening the fasteners to prevent rounding or deforming the corners of the bolts. Make sure the wrenches are the correct size and fit properly. In the case of socket heads, the wrench should have sharp, un-worn edges. With a few precautions during assembly the products should provide years of service.

WARNING

PERFORM REGULAR INSPECTIONS ON THE WINCH, WINCH MOUNT, AND RELATED HARDWARE. NEVER OPERATE THE WINCH OR WINCH MOUNT WITH DAMAGED OR MISSING PARTS. FAILURE TO FOLLOW THIS WARNING MAY CAUSE VEHICLE DAMAGE AND OPERATOR INJURY OR DEATH.