

Warn Industries, Inc.

12900 S.E. Capps Road

Clackamas, OR USA 97015-8903

1-503-722-1200 FAX: 1-503-722-3000

www.warn.com

Customer Service / Service Clients: 1-800-543-9276

International Sales Support / Les Ventes internationales

Soutien: 1-503-722-3005

© 2012 Warn Industries, Inc.
WARN®, the WARN logo are registered trademarks of Warn Industries, Inc.
WARN® et le logo WARN sont des marques déposées de Warn Industries, Inc.



(78") ZEON CONTROL PACK RELOCATION KIT

**INSTALLATION GUIDE
GUIDE D'INSTALLATION**

English 1



Zeon Control Pack Relocation Kit 78" Cable Length

Every winching situation has the potential for personal injury. In order to minimize that risk, it is important to read this guide and The Basic Guide to Winching Techniques carefully. Please familiarize yourself with the operation of your winch before using it and be constantly safety oriented. In this guide we provide important safety information and instructions on how to install your Control Pack Relocation Kit. Please read the Basic Guide to Winching Techniques for information on how to properly use your winch and proper rigging techniques.

Please keep this manual and other product literature found in this kit for future reference. Should you be missing any of the necessary instructions, please visit www.warn.com or contact us at the number below.

TABLE OF CONTENTS:

SAFETY

Symbol Index2
 General Safety Precautions3

INSTRUCTIONS

Before you Begin4
 Parts List4
 Tools Required5
 Torque Specifications5
 Installation Instructions.....6-10
 Remove Control Pack From Winch.....6-7
 Disassembling the Control Pack.....7-8
 Determine contactor mounting location and cable routing path9
 Mounting the Contactor9-10
 Connecting the Contactor..... 11

Warn Industries Inc.
 12900 SE Capps Road
 Clackamas, OR 97015
 USA

Customer Service: (800) 543-9276
 International Fax: (503) 722-3005
 Fax: (503) 722-3000
www.warn.com

WARN® and the WARN logo are registered trademarks of Warn Industries, Inc.
 © 2012 Warn Industries, Inc.

SYMBOL INDEX

SYMBOL	EXPLANATION
	Read All Product Literature
	Always Wear Hearing and Eye Protection
	Never Use Winch as a Hoist
	Finger/Fairlead Crushing Hazard
	Hand Piercing/Cutting Hazard
	Explosion/Bursting Hazard
	Never Route Electrical Cables through Sharp Edges Hazard
	Avoid Installing Electrical Cables around Pinch and Wear/Abrasion Points

SYMBOL	EXPLANATION
	Always Wear Leather Gloves
	Do Not Move People
	Always Use Supplied Hook Strap
	Fairlead Pinch Point
	Hot Surface Hazard
	Fire and Burn Hazard
	Never Route Electrical Cables through or near Moving Parts Hazard
	Exposed Wiring Hazard, Insulate Exposed Wiring and Terminals
	Never Hook Back on Rope

Warnings and Cautions



As you read these instructions, you will see WARNINGS, CAUTIONS, NOTICES and NOTES. Each message has a specific purpose. WARNINGS are safety messages that indicate a potentially hazardous situation, which, if not avoided could result in serious injury or death. CAUTIONS are safety messages that indicate a potentially hazardous situation which, if not avoided, could result in minor or moderate injury. A CAUTION may also be used to alert against unsafe practice. CAUTIONS and WARNINGS identify the hazard, indicate how to avoid the hazard, and advise of the probable consequence of not avoiding the hazard. NOTICES are messages to avoid property damage. NOTES are additional information to help you complete a procedure. **PLEASE WORK SAFELY!**

WARNING

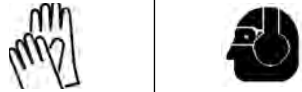

MOVING PARTS ENTANGLEMENT HAZARD
Failure to observe these instructions could lead to serious injury or death.

- General Safety:**
- **Always** Know Your Winch. Take time to fully read the Instructions and/or Operations Guide, and/or Basic Guide to Winching Techniques, in order to understand your winch and its operations.
 - **Always** keep wired remote control lead and power cord clear of the drum, rope, and rigging. Inspect for cracks, pinches, frayed wires or loose connections. Damaged components must be replaced before operation.

WARNING



FALLING OR CRUSHING HAZARD
Failure to observe these instructions could lead to serious injury or death.

- **Always** stand clear, keep hands clear, keep others away.

WARNING

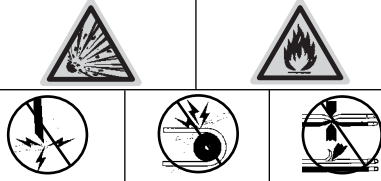

CHEMICAL AND FIRE HAZARD

- Failure to observe these instructions could lead to serious injury or death.
- **Always** remove jewelry and wear eye protection.
 - **Never** route electrical cables across sharp edges.
 - **Never** route electrical cables near parts that get hot.
 - **Never** route electrical cables through or near moving parts.
 - **Always** place the supplied terminal boots on wires and terminals as directed by the installation instructions.
 - **Never** lean over battery while making connections.
 - **Never** route electrical cables over battery terminals.
 - **Never** short battery terminals with metal objects.
 - **Always** verify area is clear of fuel lines, fuel tank, brake lines, electrical wires, etc., when drilling.
 - **Always** consult operator's manual for proper wiring details.
 - **Always** insulate and protect all exposed wiring and electrical terminals.
 - **Never** mount contactor with electrical terminals touching metal objects.

CAUTION

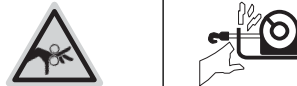

MOVING PARTS ENTANGLEMENT HAZARD
Failure to observe these instructions could lead to minor or moderate injury.

- To avoid injury to hands or fingers:
- **Never** leave remote control where it can be activated during free spooling, rigging, or when the winch is not being used.
 - **Never** leave the winch remote control plugged in when installing, freespooling, rigging, servicing or when the winch is not being used.

- Please familiarize yourself with the components.
- Mounting Kit (PN89960): Includes all hardware to mount your contactor.

Parts List

Description	Qty	Part Number
78" Wire Assembly Kit		89960
Relocation Kit Contactor Terminal Separator	1	89371
Wire housing top	1	89372
Terminal boot	4	2090
Rectangle washer	2	82462
M4 Bolt	2	64503
M6 Bolt	2	65989
M6 Nylock Nut	2	60595
Butt splice	1	85978
78" ground extension	1	89957
78" cable assembly	1	89967

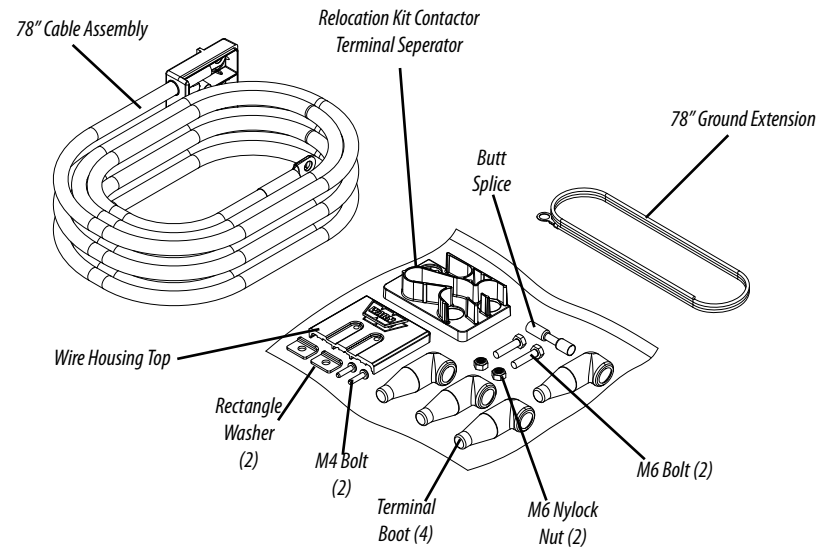

BEFORE YOU BEGIN

Tools Required

- Torx Driver Set
- Ratchet/Wrench Set (Standard/Metric)
- Drill and Drill Bit Set
- Wire Cutters
- Wire Strippers/Wire Crimps
- Torque Wrench (30 lb. ft. capacity)
- Zip Ties
- Cable Protection (i.e., flexible electrical conduit or electrical tape)

Torque Specifications

Please use the recommended torque specifications when assembling this product unless otherwise specified in the instructions.

FASTENER SIZE (Grade 5)	FASTENER TORQUE		FASTENER SIZE (Class 8.8)	FASTENER TORQUE	
	lb-ft	(N.m)		lb-ft	(N.m)
1/4"	8	(11)	M4	(2)	3
5/16"	17	(23)	M5	(4.5)	6
3/8"	30	(40)	M6	(7.5)	10
7/16"	48	(66)	M8	(18)	25
1/2"	74	(100)	M10	(37)	50
9/16"	106	(144)			
5/8"	148	(200)			
3/4"	269	(364)			





Inspect all nuts and bolts on all related hardware periodically. Tighten all nuts that appear to be loose. Stripped, fractured, or bent bolts or nuts need to be replaced.

INSTALLATION INSTRUCTION

REMOVE CONTROL PACK FROM WINCH

⚠ WARNING To prevent serious injury or death. Always place the supplied terminal boots on wires and terminals as directed by the installation instructions.

⚠ WARNING To prevent serious injury or death from electrical fire:

-  Never route electrical cables across sharp edges.
-  Never route electrical cables near parts that get hot.
-  Never route electrical cables through or near moving parts.
-  Avoid pinch and wear/abrasion points when installing all electrical cables.

⚠ WARNING Always insulate and protect all exposed wiring and electrical terminals.

1. Disconnect the vehicle battery cables, negative terminal first. All work with electrical wires and cables must be completed with the battery completely disconnected from the vehicle wiring.
2. Disconnect the ground cable on the under side of the winch (see figure 1). Make sure the small black wire that connects to the control pack is disconnected and hanging freely.

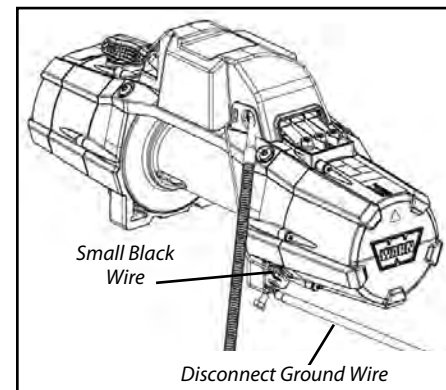

Figure 1

3. Remove the top buss bar cover by unscrewing the fastener holding it in place. Retain fastener for later use.
4. Remove the three motor terminal nuts and lock washers that secure the buss bars to the motor. Retain the terminal nuts and lock washers for future step.

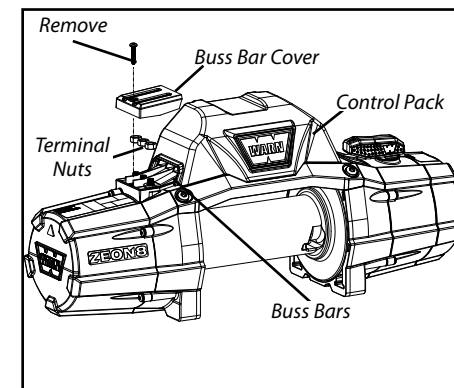

Figure 2

INSTALLATION INSTRUCTION

- Remove the four (4) flat head torx drive screws located on the underside of the tie plate. **NOTE: Rope may need to be spooled out to complete this step.**
- Once all four (4) control pack screws have been removed, gently lift the control pack off of the tie plate and set aside to be further disassembled.

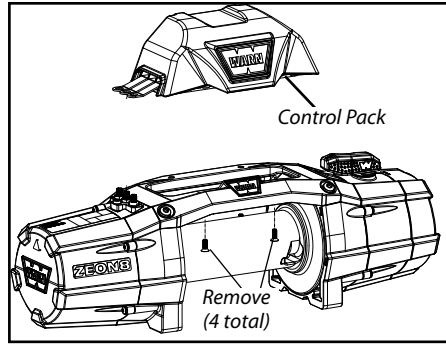

Figure 3

- Remove the motor terminal buss bar insulator after control pack has been removed.

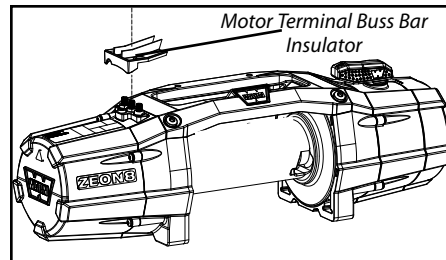

Figure 4

DISASSEMBLING THE CONTROL PACK

- Disassemble the control pack by removing the four (4) flat head torx drive screws.
- Gently lift the control pack cover off of the contactor plate assembly. **The cover should remain wired to the contactor at this time.** Simply move the cover to one side or out of the way while working on the contactor.

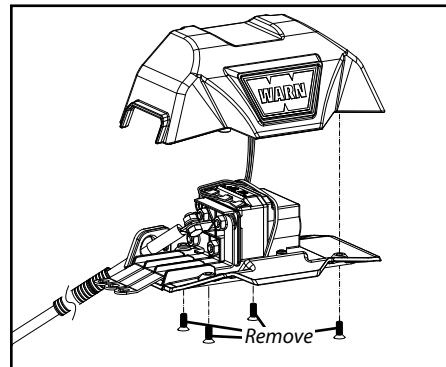

Figure 5

INSTALLATION INSTRUCTION

- Remove the contactor from the control pack plate by unscrewing the flat head torx drive screws and lock nuts.

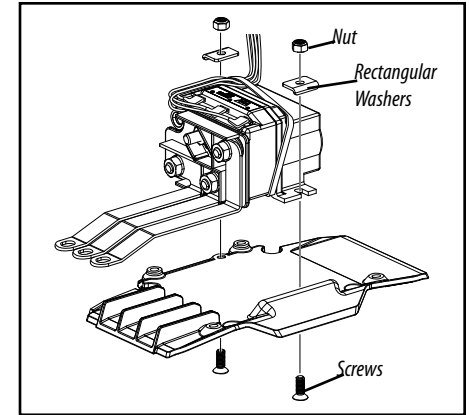

Figure 6

- Remove the power cable, all buss bars and installed buss bar separator connected to the contactor.

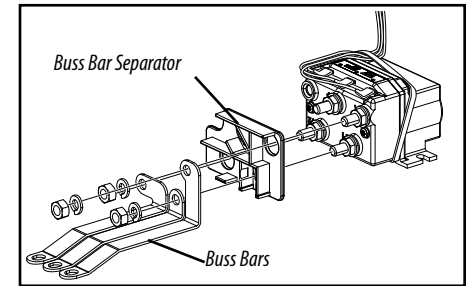

Figure 7

- Be sure to keep all hardware for reinstallation.

- Cut and remove zip tie securing socket wiring bundle to contactor.

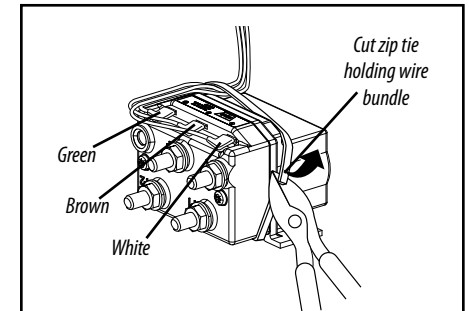

Figure 8

- Unplug the white, brown and green wires from the top of the contactor. Carefully set aside the contactor.

- Open remote socket cover located on the control pack cover.

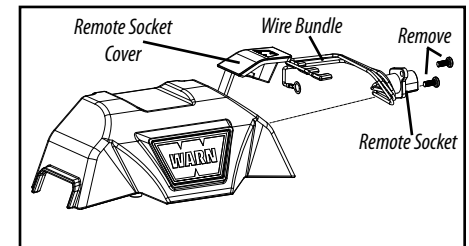

Figure 9

- Using a torx driver to remove the two machine screws holding the socket in place.

- Remove the remote socket by gently pulling wire bundle out of the control pack cover.

DETERMINE CONTACTOR MOUNTING LOCATION AND CABLE ROUTING PATH

To determine the contactor mounting location it is recommended that the contactor be mounted on a solid mounting surface and easily accessible. Contactor should be in a location that is as clean and dry as possible. Ensure the contactor mounting location selected provides sufficient clearance from all metal structures. Exact location will vary depending on the vehicle.

To determine the winch motor cable assembly and ground wire routing path, verify the path will allow the winch motor cable assembly and ground wire to be routed avoiding sharp edges, parts that get hot and moving parts. Consider chassis flex and vibration which might damage cable.

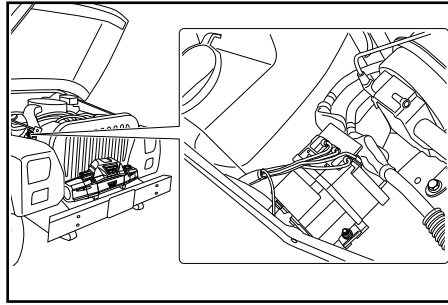

Contactor Mounting Location Example

MOUNTING THE CONTACTOR

WARNING To prevent serious injury or death. Always place the supplied terminal boots on wires and terminals as directed by the installation instructions.

WARNING To prevent serious injury or death from electrical fire:



Never route electrical cables across sharp edges.



Never route electrical cables near parts that get hot.



Never route electrical cables through or near moving parts.



Avoid pinch and wear/abrasion points when installing all electrical cables.

WARNING Always verify area is clear of fuel lines, fuel tank, brake lines, electrical wires, etc., when drilling.

WARNING Never mount contactor with electrical terminals touching metal objects.

After determining contactor mounting location, you are ready to mount your contactor.

1. Use the contactor as a template to drill the holes needed to mount the contactor.
2. Drill the holes to 6.5mm diameter. **WARNING! Be sure to check the area before you drill to avoid hitting any electrical cables or gas lines.**
3. Install the contactor using the supplied bolts, rectangular washers and lock nuts.

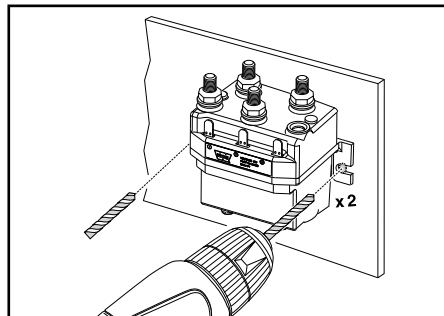

Figure 10

NOTE: Before making any connections, you will be routing the winch motor cable assembly and ground extension wire only.

4. Once you have determined your winch motor cable assembly and ground wire path, route the cable assembly and the ground extension wire from the winch to the contactor. Loosely secure in place using zip ties.
5. Confirm cables are protected from sharp edges, heat and moving parts. Consider chassis flex and vibration which might damage cable.
6. Locate and install the relocation kit contactor terminal separator (included in kit).
7. Install the red wire (with ring terminal) from the remote socket wire bundle to the positive (+) contactor terminal.

WARNING Always insulate and protect all exposed wiring and electrical terminals.

8. Install protective electrical boots on each of the cables.
9. Connect cables to contactor using the terminal nuts and lock washers previously removed. Connect the labeled cables (A, F1 and F2) to corresponding terminal. *Torque nuts to 8.5-9 N-m (75-80 in. lbs.).* Refer to Figure 12 for Final Cable Assembly.
10. Reconnect the winch remote socket wires back onto the contactor's spade terminals. The white wire gets connected to spade terminal 1, brown wire to spade terminal 2, and green wire to spade terminal 3.
11. Using zip ties or purchased hardware, secure the remote socket into place near the contactor. *If you require greater socket location flexibility, order Warn PN 86605.*

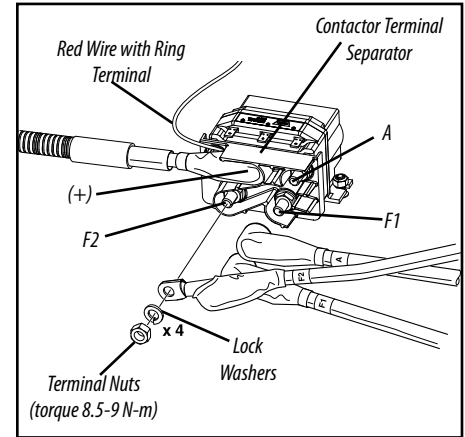

Figure 11

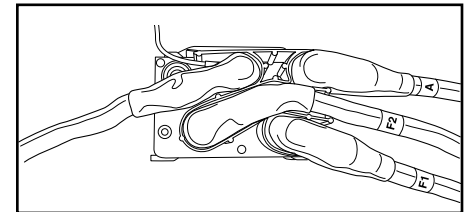

Figure 12

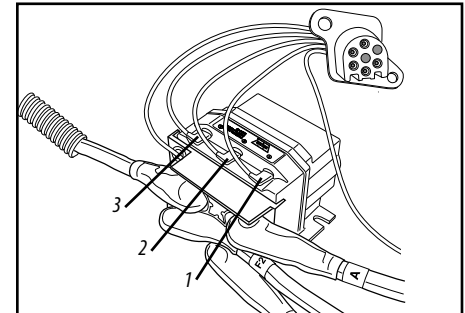

Figure 13

INSTALLATION INSTRUCTION

CONNECTING THE CONTACTOR

⚠ WARNING To prevent serious injury or death from electrical fire:



Never route electrical cables across sharp edges.



Never route electrical cables near parts that get hot.



Never route electrical cables through or near moving parts.



Avoid pinch and wear/abrasion points when installing all electrical cables.

⚠ WARNING Always verify area is clear of fuel lines, fuel tank, brake lines, electrical wires, etc., when drilling.

⚠ WARNING Never mount contactor with electrical terminals touching metal objects.

1. Attach the wire terminal housing to the motor terminals on the winch using terminal nuts and lock washer previously removed. *Torque nuts to 8.5-9 N-m (75-80 in. lbs.)*
2. Install the cover plate and fasten with the two supplied machine screws. Do not over tighten screws, over tightening could damage the plastic components.
3. Use the supplied butt splice connector and the black extension wire to lengthen the contactor ground wire.
4. Reconnect the ground cable and small black wire to winch motor ground. *Secure fasteners to specified torque requirements in torque specification chart found in these instructions.*
5. Carefully inspect electrical cable routing. Is it neat and tidy? Zip tie and secure electrical cables. Zip ties should be snug, but not cutting into wire insulation. Use electrical tape, pieces of rubber hose or electrical conduit to protect electrical cables and wire harness where needed to avoid electrical cable insulation wear or abrasion.
6. Attach battery cables, red (positive) cable FIRST, black (negative) second. Install boots as appropriate to protect connections. Torque battery terminal fasteners as directed by vehicle service manual.
7. Make sure to plug in the winch remote and ensure that drum is turning in the proper direction when spooling in/out before using in the field.

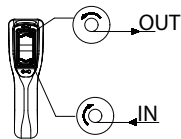

8. Installation complete.

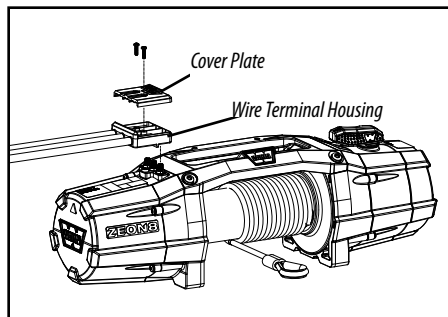

Figure 14

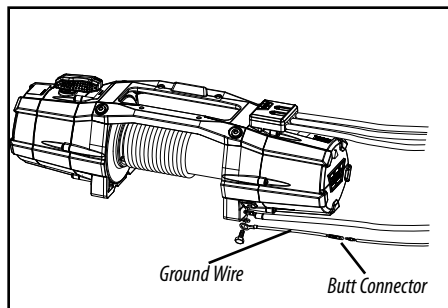

Figure 15

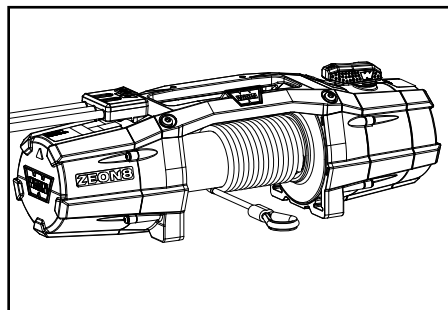

Figure 16