



INSTALLATION INSTRUCTIONS

ELITE SERIES REAR BUMPER AND TIRE CARRIER

Part Number: 89525/89800

Application: 2007+ Jeep JK

GENERAL SAFETY PRECAUTIONS

Your safety, and the safety of others, is very important. To help you make informed decisions about safety, we have provided installation and operating instructions and other information on labels and in this guide. This information alerts you to potential hazards that could hurt you or others. It is not possible to warn you about all potential hazards associated with this product, you must use your own good judgment.

CARELESS INSTALLATION AND OPERATION CAN RESULT IN SERIOUS INJURY OR EQUIPMENT DAMAGE. READ AND UNDERSTAND ALL SAFETY PRECAUTIONS AND OPERATING INSTRUCTIONS BEFORE INSTALLING AND OPERATING THIS PRODUCT.

This guide identifies potential hazards and has important safety messages that help you and others avoid personal injury or death. **WARNING** and **CAUTION** are signal words that identify the level of hazard. These signal words mean:

▲ **WARNING** signals a hazard that could cause serious injury or death, if you do not follow recommendations. ▲ **CAUTION** signals a hazard that may cause minor to moderate injury, if you do not follow recommendations.

This guide uses NOTICE to call attention to important mechanical information, and Note: to emphasize general information worthy of special attention.

▲ WARNING

Impact and Moving Parts Entanglement Hazard

FAILURE TO OBSERVE THESE INSTRUCTIONS COULD LEAD TO SEVERE INJURY OR DEATH

- Always use extreme caution when drilling on any vehicle. Make sure that all fuel lines, brake lines, electrical wires, and other objects are not punctured or damaged when / if drilling on the vehicle. Thoroughly inspect the area to be drilled (on both sides of material) prior to drilling, and relocate any objects that may be damaged. Failure to inspect the area to be drilled may result in vehicle damage, electrical shock, fire or personal injury.
- Always wear safety glasses when installing this kit. A drilling operation will cause flying metal chips. Flying chips can cause eye injury.
- Always use extreme caution when cutting and trimming during fitting.
- Always remove jewelry and wear eye protection.
- Never lean over battery while making connections.
- Never route electrical cables:
 - Across any sharp edges.
 - Through or near moving parts.
 - Near parts that become hot.
- Always insulate and protect all exposed wiring and electrical terminals.
- Always install terminal boots as directed in installation instructions.
- Always use appropriate and adequate care in lifting components into place.
- Always insure components will remain secure during installation and operation.
- Always tighten all nuts and bolts securely, per the installation and operation.
- Always perform regular inspections and maintenance on the winch, winch mount and related hardware.
- Never ever operate this WARN product with damaged or missing parts.

Read installation and operating instructions thoroughly.

WARN INDUSTRIES, INC. 12900 S.E. Capps Road,
Clackamas, OR USA 97015-8903, 1-503-722-1200, FAX: 1-503-722-3000
Customer Service: 1-800-543-9276
Dealer Locator Service: 1-800-910-1122
International Fax: 1-503-722-3005

CAUTION

Moving Parts Entanglement Hazard

FAILURE TO OBSERVE THESE INSTRUCTIONS COULD LEAD TO MINOR OR MODERATE INJURY

- Always take time to fully read and understand the installation and Operations Guide included with this product.
- Never operate this product if you are under 16 years of age.
- Never operate this product when under the influence of drugs, alcohol or medications.

Read installation and operating instructions thoroughly.

NOTICE

Equipment Damage

- Always refer to the Installation and Specification Guide, supplied in the winch kit, for all wiring schematics and specific details on how to wire this WARN product to your vehicle.

Read installation and operating instructions thoroughly.

BEFORE YOU BEGIN

The WARN Rock Crawler Rear Bumper is designed to mount over the factory towing receiver. A WARN Tire Carrier (PN 89800) must be installed before installation of the bumper.

NOTE: The Highlift Jack Mount (PN 90030) is sold separately.

TABLE OF CONTENTS

Tools Required.....	page 2
Torque Specifications.....	page 2
Parts List.....	page 3-4
Installation.....	page 5-10
Maintenance/Care.....	page 11

TOOLS REQUIRED

- Standard socket set
- Metric socket set
- 3/8 Ratchet
- 3/8 Extension
- Drill motor and bits (1/4" and 1/2")
- Wire stripper crimpers

TORQUE SPECIFICATIONS

Please use the recommended torque specifications when assembling this product unless otherwise specified in the instructions.

1/4	8 lb. ft. (10.8 N-m)
5/16	17 lb. ft. (23.0 N-m)
3/8	30 lb. ft. (40.7 N-m)
7/16	50 lb. ft. (67.8 N-m)
1/2	75 lb. ft. (101.7 N-m)

PARTS LIST

Ref.	Part Number	Description	Qty
1	88935	BUMPER	1 EA
2	89985	COVER PLATE	1 EA
3	80252	RUBBER PLUG	1 EA
4	74288	CRUSH TUBE	2 EA
5	89824	FRAME BRACKET RH	1 EA
6	89896	FRAME BRACKET LH	1 EA
7	38452	NUT AND STICK ASSY	6 EA
8	710269	1/2-13 X 4 1/2 HEX BOLT	4 EA
9	9213	1/2 FLAT WASHER	20 EA
10	29060	1/2 NUT NYLOCK	4 EA
11	6818	1/2-13 X 1 1/2 HEX BOLT	4 EA
12	6959	1/2-13 X 1 1/4 HEX BOLT	2 EA
13	2596	LOCK WASHER 1/2"	6 EA
14	6960	CPSCR HEX 3/8-16X1.25	2 EA
15	2317	3/8 - 16	2 EA
16	7676	7/16 FLAT WASHER	8 EA
17	2146	7/16 LOCK WASHER	8 EA
18	89488	7/16 HEX NUT	8 EA
19	27309	CAP SCREW 10-24	2 EA
20	63241	NUT NYLOCK 10-24	2 EA

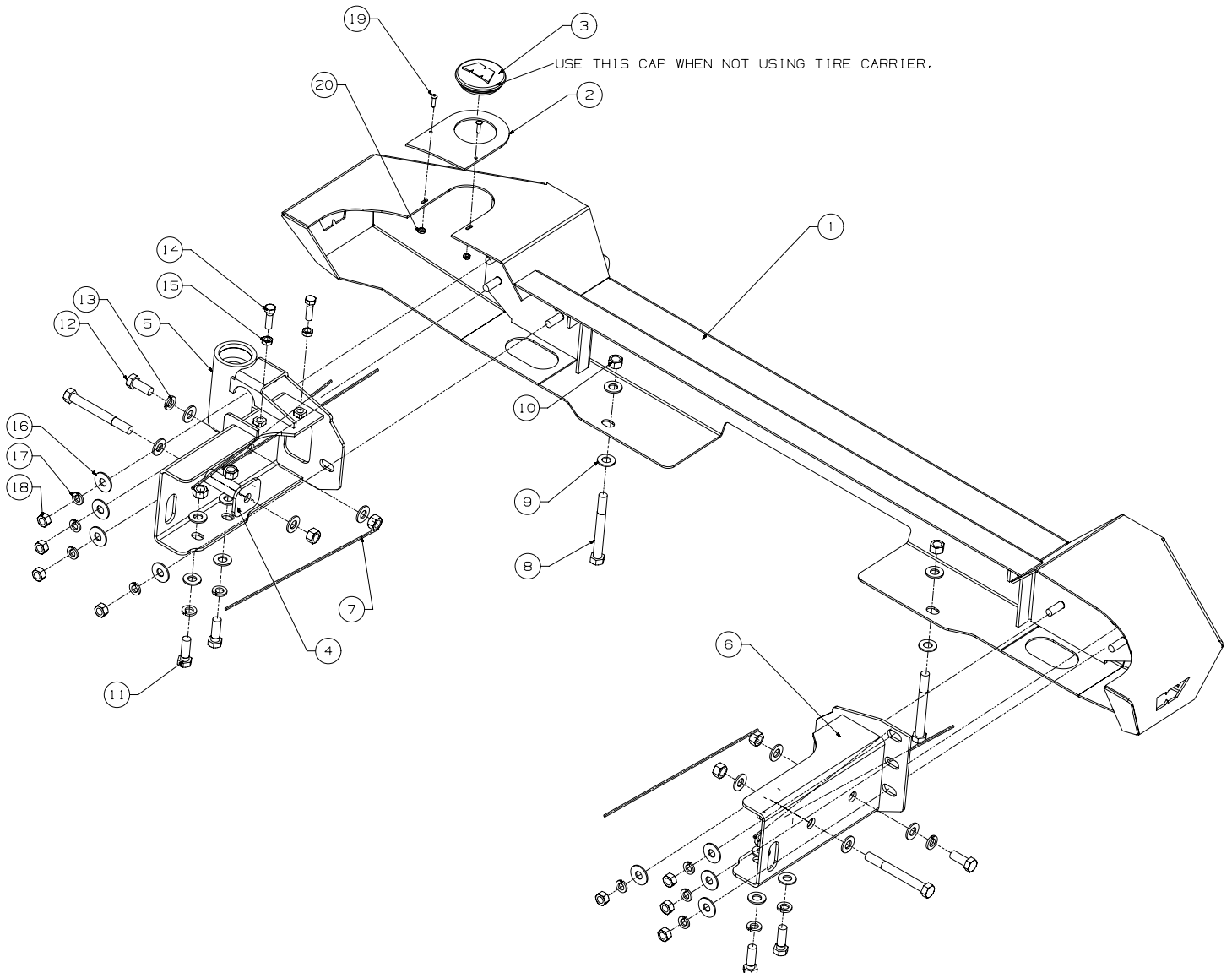

Ref.	Part Number	Description	Qty	Ref.	Part Number	Description	Qty
1.	89794	TIRE CARRIER	1 EA	24.	6960	HEX BOLT 3/8-16 X 1 1/4	6 EA
2.	89788	TIRE SUPPORT	1 EA	25.	11524	FLAT WASHER 3/8	12 EA
3.	90038	BRAKE LIGHT BRKT	1 EA	26.	90049	HEX NUT NYLOCK	1 EA
4.	89792	TAILGATE BRACKET	1 EA	27.	90298	THRUST WASHER	2 EA
5.	89790	TIRE MOUNT	1 EA	28.	90299	OIL LITE BUSHING	2 EA
6.	36325	WHEEL STUD	3 EA	29.	89903	1/2-20 JAM NUT RH	1 EA
7.	90047	WEAR BLOCKS	2 EA		90141	1/2-20 JAM NUT LH	1 EA
8.	89904	TENSIONER TUBE	1 EA				
9.	90126	BUSHINGS	4 EA				
10.	89902	TIE ROD END	1 EA				
11.	90037	TIE ROD END	1 EA				
12.	13253	HEX BOLT 1/4-20	4 EA				
13.	1320	FLAT WASHER 1/4-20	4 EA				
14.	6725	HEX NUT NYLOCK 1/4-20	4 EA				
15.	63399	HEX BOLT 1/2-13 X 3.0	2 EA				
16.	9213	FLAT WASHER 1/2"	4 EA				
17.	29060	HEX NUT NYLOCK	2 EA				
18.	13470	HEX BOLT 5/16 X 1	1 EA				
19.	2079	HEX NUT 5/16	1 EA				
20.	11709	HEX BOLT 3/8 X 3 1/4	1 EA				
21.	6779	HEX NUT NYLOCK	7 EA				
22.	1971	CAP SCREW 1/4-20	2 EA				
23.	6725	NUT LOCK 1/4-20	2 EA				

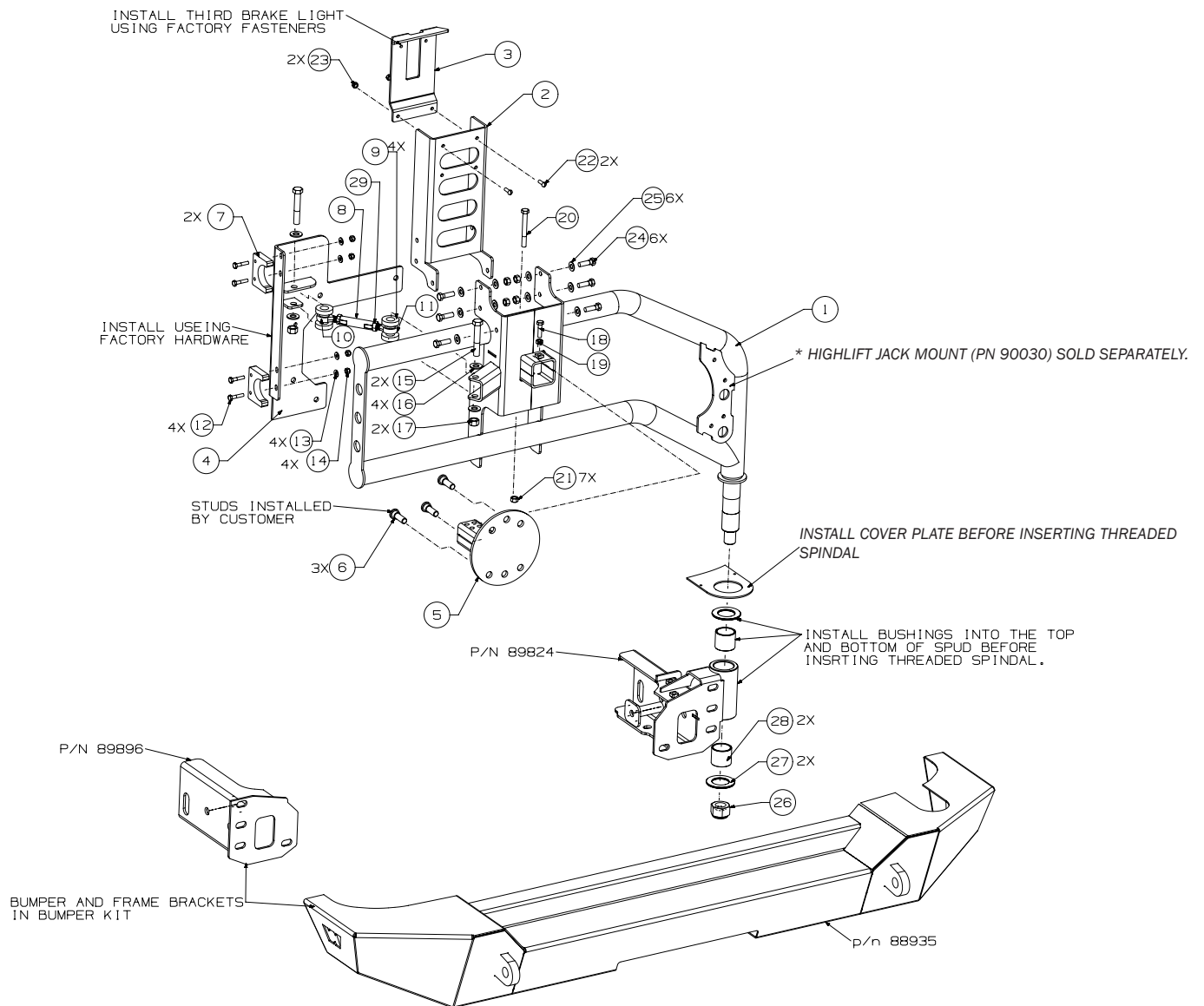

INSTALLATION INSTRUCTIONS

1. Remove the factory rear bumper and brackets from the vehicle. See Figure 1.
2. Disassemble the third brake light and unplug it from the wire loom that comes out of the tailgate.
3. Remove the factory tire mount from the tailgate. **NOTE: Do not remove unless you are installing PN89800 Tire Carrier.** See Figure 1B.
4. Locate and install the frame brackets to each side of the vehicle. **NOTE: Make sure you install both bushings in the right hand bracket before you install step 5.** See Figure 2.
5. Insert the frame crush tubes into the frame from the inside of the frame rail. **NOTE: You may need to remove the rear body mount bolts in order to do this.** Insert the $\frac{1}{2}$ x 4-1/2" bolt and the thick flat washer, supplied in your hardware kit, through the frame bracket, frame and into the crush tube. Install a flat washer and $\frac{1}{2}$ " lock nut onto the bolt. See Figure 2B.

NOTE: If the thick washer is not used under the bolt head, the end of the bolt will rub on the body mount washer and squeak.



Figure 1



Figure 1B



Figure 2

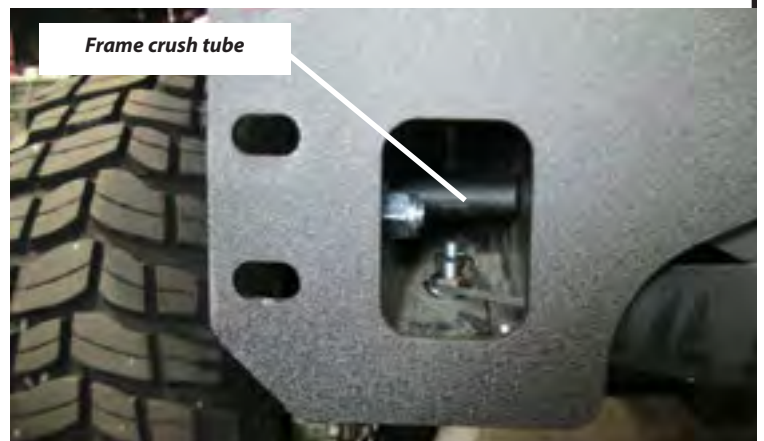

Figure 2B

WARNING

- Always wear safety glasses when installing this kit. A drilling operation will cause flying metal chips. Flying chips can cause eye injury.

6. Insert a 1/2" x 1-1/4" long bolt with flat washer through the frame bracket and the rear most hole in the side of the frame. Reach into the opening in the frame bracket and install a flat washer, lock washer, and 1/2" weld nut with handle onto the bolt. See Figure 3.

⚠ WARNING

- Always wear safety glasses when installing this kit. A drilling operation will cause flying metal chips. Flying chips can cause eye injury.

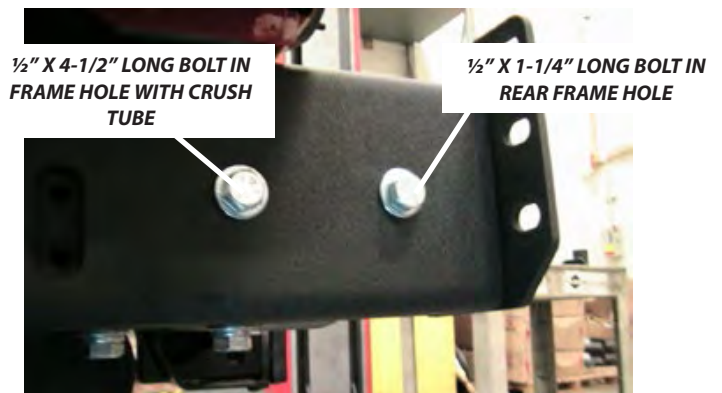

Figure 3

7. Install a 1/2" x 1 1/2" long bolt and flat washer into each of the two holes in the bottom of the frame bracket. Some frames do not have these holes already drilled in the bottom. If your frame does not have these holes, drill out each location using a drill motor and 1/2" drill bit. Once the holes are drilled install the bolts and flat washers from the bottom up into the frame and install a flat washer, lock washer, and 1/2" weld nut with handle onto each bottom. See Figure 4.



Figure 4

8. Do not tighten the frame bracket mounting hardware at this time. The right hand frame bracket that has the welded tube on it needs to be adjusted first. Tighten the hardware just enough to take most of the slack out of the fit between the vehicles frame and the frame bracket. Install the M10 bolts and nut shown in photo. These are used to align the frame bracket tube by screwing them in, and the nuts to lock them in place once in position. This will allow you to align the frame bracket tube to the tailgate hinges for a smooth operation. See Figure 5.



Figure 5

9. Install the tailgate bracket and wear blocks at this time using the hardware from the old tire mount. There is provided 1/4-20 hardware in your hardware kit to attach the wear blocks. Do not tighten the wear blocks completely because you will need to adjust them to the tube after you adjust the frame bracket. See exploded view. See Figure 6.

NOTE: Reinstall the factory bolts back into the tailgate where there are open holes.



Figure 6

10. To aid in the installation of the tire carrier, grease the threaded spindle of the tire carrier before you install it into the tire carrier frame bracket. **Note: Do not forget to place the bumper cover plate over the spindle prior to installing the tire carrier into the bracket.** Make sure the profile will match the bumper before you install it. Also place the large oil lite flat bushing washer on to the spindle as well. Install the tire carrier into the frame bracket, once all the way in install the other oil lite flat washer, the 1" flat washer and the 1-14 nylock nut. Tighten until the slack is out of the tire carrier making sure it swings easily. See Figure 7 and 7B.



Figure 7



Figure 7B

11. Swing the tube assembly toward the tailgate; you will notice that the tube assembly does not line up with the body lines of the tailgate. Adjust the jackscrews in figure 5 on the frame bracket and tighten the nuts that you installed until the tube assembly lifts into a suitable position that matches the lines of the vehicle. You may then set the wear blocks and tighten the 1/4-20 hardware you installed in Figure 8.



Figure 8

12. Tighten the passenger side frame bracket completely after you have aligned the tire carrier using the jack bolts to the rear of the vehicle. At this time as you will want to make sure the tube assembly stays in alignment.

15. You are now ready to connect the tire carrier, to the tailgate bracket you previously installed. Take the tie rod ends and install the $\frac{1}{2}$ -20 jam nut on each one. Thread the tie rod ends into each end of the tube. Wait to secure the jam nuts until you have attached it to the vehicle as you will need to adjust them. There is also four rubber bushings to pad the tie rod ends from rattling between the bracket. Assemble using the two $\frac{1}{2}$ -13 hex head bolt, four flat washers and two $\frac{1}{2}$ -13 nylock nuts.

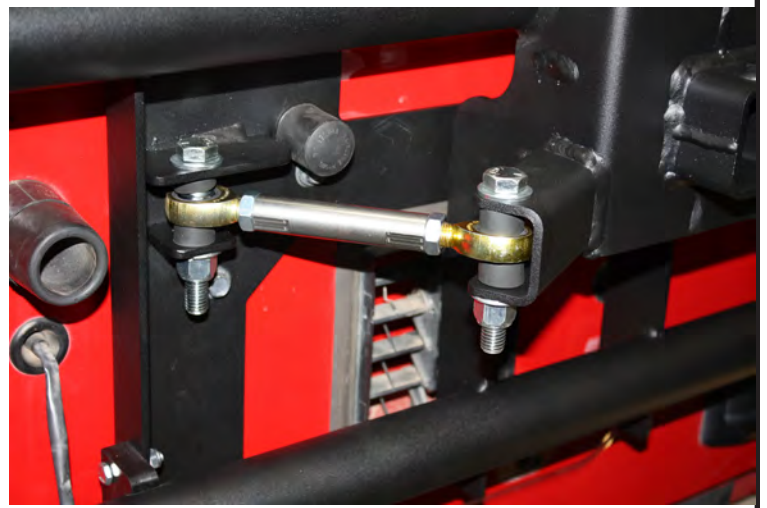

Figure 9

NOTE: Please note that there is a left and right hand jam nuts, and tie rod ends. Do not force thread any of these items. The tensioner tube also has a left and right hand threads in it as well.

Adjustment: The tubes should hit the wear block about an inch to an inch and a half before the door fully closes. This will give an accurate and tight fit. Tighten the jam nuts now. See Figure 9.

16. You can now install the tire support bracket with the $\frac{3}{8}$ hex head bolts, washers and nuts. Refer to exploded view if needed and parts list. See figure 10.



Figure 10

17. You are now ready to install the third brake light bracket using hardware provided refer to your exploded view and parts list. You will be using the factory screws that you removed to reattach the light to the bracket. It will be required to lengthen the wiring to the third brake light. Use approximately (2) twelve inch 18ga. wires and (4) butt connectors. Make sure you reconnect the wire harness to the light, and route the harness so it does not interfere with the function of the tire carrier. See figure 11

NOTE: You will have to cut the plastic on the light to make it fit the new bracket.

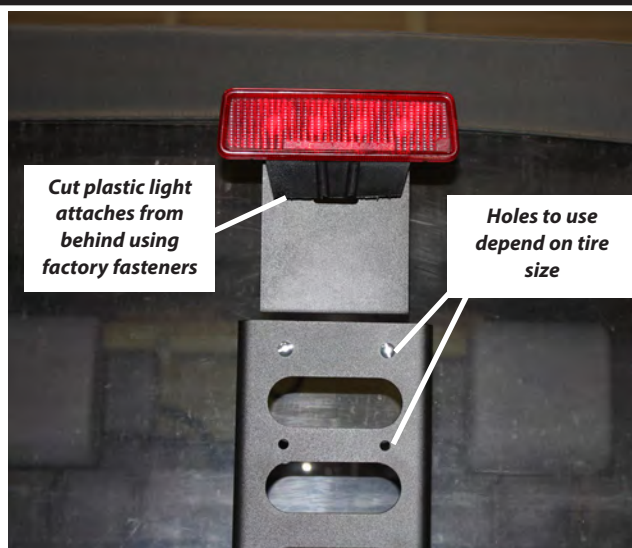

Figure 11

18. Before we install the spare tire mount and tire lets attach the bumper to make it easier to access. Remember the left hand frame bracket is still loose so it will need to be tightened after the bumper is in position. Trim the wires off the wire nut assemblies using a pair of side cutters, and bending the wire at the same time. You'll notice that the bumper has studs that will align with the frame brackets. Have someone help you slide the bumper onto the frame brackets.

Make sure the small cover plate is on top of the bumper in order to be fastened to the top of the bumper to cover up the slot. Install the required hardware.

Install the 7/16 flat washers, lock washers and nuts onto the bumper studs. Center the bumper and tighten all hardware including the frame bracket. See Figure 12.



Figure 12

19. Using the bottom of the bumper as a guide, drill a 1/2" hole through the rear cross member of the frame. Drill through the bottom and top of the cross member. Install 1/2" by 4 1/2" bolt, flat washers and nylock nuts at this time. See exploded view. See figure 13.

⚠ WARNING

- Always wear safety glasses when installing this kit. A drilling operation will cause flying metal chips. Flying chips can cause eye injury.

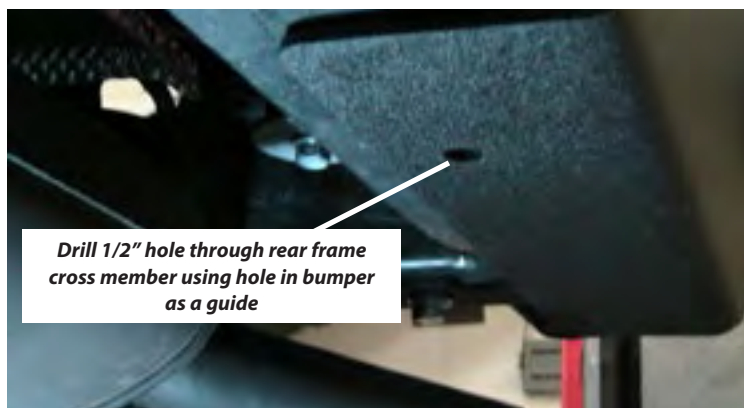

Figure 13

20. Install the studs into the tire mounting bracket by aligning the holes in the bracket to the hole in your wheel. You will have one of two patterns. Place the plate to the back of the wheel and use your lug nuts to draw the studs into the plate. You can also press the studs in using a press or a vise and a hammer. If you are using a 5 on 5 ½ wheel use the outer hole pattern. If you are using the 5 on 5 wheel, use the inner hole pattern.

21. After the wheel studs are installed, mount the tire to the bracket.

22. Lift the tire and the bracket up and insert into the tire receiver. There is a set of holes in behind the receiver, you want to mark the hole that would require you to insert the tire about ¼ to 3/8 farther but you can't at this time.

23. Remove the tire and bracket from the receiver and remove the bracket from the wheel. Place the bracket back into the receiver aligning the hole that you marked and place the long 3/8 bolt through the center of the tire carrier. Place the 3/8 lock nut on the bolt and tighten at this time.

NOTE: Depending where the hole location lands for your wheel you may have to run the bolt up through the bottom of the center bracket. Also in the event that you can't find a hole to align with you may have deflate tire and reinflate after mounting.

24. Reinstall the tire to the bracket, if adjusted correctly, the tire should compress to the tire carrier as you tighten your lug nuts. See figure 14 above.

NOTE: The plastic inner fender on the rear wheel well hangs out. We recommend that you trim this off using a hacksaw blade or a good pair of tin snips.

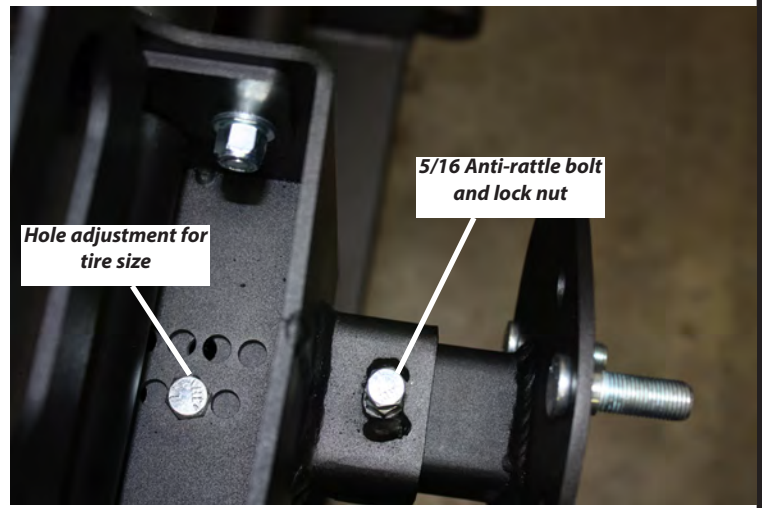

Figure 14

MAINTENANCE / CARE

- Inspect all parts on the frame brackets and bumper hardware periodically. Replace all hardware that appears rusted or deformed.
- Inspect all nuts and bolts periodically. Tighten all nuts that appear to be loose. Stripped, fractured, or bent bolts or nuts need to be replaced.

CARELESS INSTALLATION AND OPERATION CAN RESULT IN SERIOUS INJURY OR EQUIPMENT DAMAGE. READ AND UNDERSTAND ALL SAFETY PRECAUTIONS AND OPERATING INSTRUCTIONS BEFORE INSTALLING AND OPERATING THIS PRODUCT.

