



# INSTALLATION INSTRUCTIONS

## Trans4mer Gen II Winch Carrier

Part Number: Kit 88245 (Stainless)

### GENERAL SAFETY PRECAUTIONS

Your safety, and the safety of others, is very important. To help you make informed decisions about safety, we have provided installation and operating instructions and other information on labels and in this guide. This information alerts you to potential hazards that could hurt you or others. It is not possible to warn you about all potential hazards associated with this product, you must use your own good judgment.

**CARELESS INSTALLATION AND OPERATION CAN RESULT IN SERIOUS INJURY OR EQUIPMENT DAMAGE. READ AND UNDERSTAND ALL SAFETY PRECAUTIONS AND OPERATING INSTRUCTIONS BEFORE INSTALLING AND OPERATING THIS PRODUCT.**

This guide identifies potential hazards and has important safety messages that help you and others avoid personal injury or death. **WARNING** and **CAUTION** are signal words that identify the level of hazard. These signal words mean:

**▲WARNING** signals a hazard that could cause serious injury or death, if you do not follow recommendations. **▲CAUTION** signals a hazard that may cause minor to moderate injury, if you do not follow recommendations.

This guide uses **NOTICE** to call attention to important mechanical information, and **Note:** to emphasize general information worthy of special attention.

### **▲ WARNING**

Impact and Moving Parts Entanglement Hazard

**FAILURE TO OBSERVE THESE INSTRUCTIONS COULD LEAD TO SEVERE INJURY OR DEATH**

- Always use extreme caution when drilling on any vehicle. Make sure that all fuel lines, brake lines, electrical wires, and other objects are not punctured or damaged when / if drilling on the vehicle. Thoroughly inspect the area to be drilled (on both sides of material) prior to drilling, and relocate any objects that may be damaged. Failure to inspect the area to be drilled may result in vehicle damage, electrical shock, fire or personal injury.
- Always wear safety glasses when installing this kit. A drilling operation will cause flying metal chips. Flying chips can cause eye injury.
- Always use extreme caution when cutting and trimming during fitting.
- Always remove jewelry and wear eye protection.
- Never lean over battery while making connections.
- Never route electrical cables:
  - Across any sharp edges.
  - Through or near moving parts.
  - Near parts that become hot.
- Always insulate and protect all exposed wiring and electrical terminals.
- Always install terminal boots as directed in installation instructions.
- Always use appropriate and adequate care in lifting components into place.
- Always insure components will remain secure during installation and operation.
- Always tighten all nuts and bolts securely, per the installation and operation.
- Always perform regular inspections and maintenance on the winch, winch mount and related hardware.

Read installation and operating instructions thoroughly.

WARN INDUSTRIES, INC. 12900 S.E. Capps Road,  
Clackamas, OR USA 97015-8903, 1-503-722-1200, FAX: 1-503-722-3000  
Customer Service: 1-800-543-9276  
Dealer Locator Service: 1-800-910-1122  
International Sales/ Customer Service: 1-503-722-3008  
International Fax: 1-503-722-3005

## **⚠ CAUTION**

### **Moving Parts Entanglement Hazard**

**FAILURE TO OBSERVE THESE INSTRUCTIONS COULD LEAD TO MINOR OR MODERATE INJURY**

- **Always take time to fully read and understand the installation and Operations Guide included with this product.**

Read installation and operating instructions thoroughly.

## **NOTICE**

Equipment Damage

- **Always refer to the Installation and Specification Guide, supplied in the winch kit, for all wiring schematics and specific details on how to wire this WARN product to your vehicle.**

Read installation and operating instructions thoroughly.

## **NOTES**

This WARN Trans4mer Gen II system can be customized to give your vehicle a wide variety of looks, front-end protection and winch mounting capability. The system starts with this winch carrier that attaches to the truck's frame with brackets designed to handle up to a 16500 lb winch on some vehicles. This provides a mounting location for a Warn winch. It is durable and good looking as a stand-alone winch mount, but can be easily upgraded with some great options! You can first add a center Grille Guard Tube that provides a mounting location for other accessories. You can add a light bar that adds even more protection and includes tabs for mounting auxiliary lights. You can mount a front receiver bracket that provides a mounting location for a multi-mount Warn winch. Finally, headlamp guards that protect the headlights and front corners of the vehicle can be easily added to the grille guard.

## **BEFORE YOU BEGIN**

- Read and understand these Installation Instructions.
- Refer to the Parts Lists below and to Figures A for your specific mounting system to become familiar with the components and hardware in this kit.

## **TABLE OF CONTENTS**

Tools Required.....	page 2
Torque Specifications.....	page 2
Parts List.....	page 3
Installation.....	page 3

## **TOOLS REQUIRED**

- 5/8, 11/16 sockets and / or wrenches

## **TORQUE SPECIFICATIONS**

1/4	8 lb. ft. (10.8 N-m)
5/16	17 lb. ft. (12.5 N-m)
3/8	30 lb. ft. (40.7 N-m)
7/16	50 lb. ft. (67.8 N-m)
1/2	75 lb. ft. (101.7 N-m)

## PARTS LIST

Reference	Part Number	Qty	Description:
A6	79852 or 80247		Carrier Assembly
B1	1319	6	1/4" x 1" bolt
B2	1321	6	1/4" lock washer
B3	1322	6	1/4" nut
B4	18111	4	7/16" nut
B5	18113	4	7/16" lock washer
B6	18118	4	7/16" x 1 1/2" bolt
B7	74636	8	7/16" washer
B8	11075	8	Plastic plug
B9	13558	1	License plate bracket
B10	26034	1	Solenoid bracket
B11	80252	2	Rubber insert
B12	90315	6	7/16 x 1 1/2" bolt
B13	220026	12	7/16 washer
B14	710123	6	7/16 lock nut

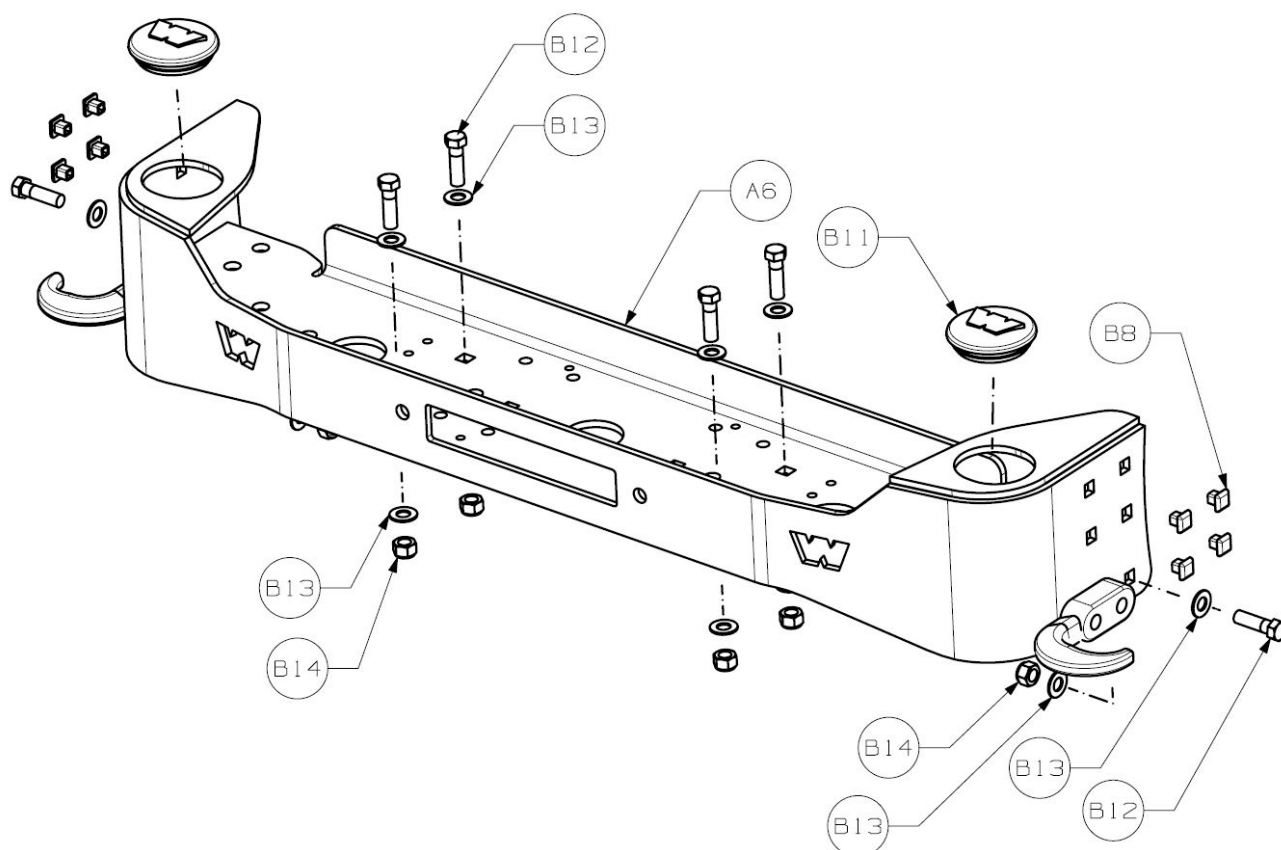

*Figure A*

NOTE: Follow the instructions step by step for fastest installation. Do not securely tighten fasteners until directed to do so.

### MID FRAME CARRIER PRE-ASSEMBLY

1. Place mid frame carrier (A6) on a flat surface like the floor or a workbench.
2. If you are not installing the grille guard tube, the rubber inserts (B11) can be installed at this time. The inserts should be placed over the holes shown and aligned for best appearance then pressed into the hole.
3. If the center tube and/or headlight guards are not being installed, the 4 square plastic plugs (B8) can be installed at this time. If the headlight guard tubes are being installed, do not install the plugs. See Figure A.
4. Pre-assembly is complete. Continue installing the winch mounting kit according to the instructions included with the kit.
5. Stainless fasteners (B12, B13, B14) are used in place of black fasteners, found in mounting kit.

**Warn Industries**  
**Stainless Steel Truck Accessories**

**What to expect:**

Polished stainless steel combines the beauty of a chrome-like appearance with extreme durability and corrosion resistance. With a minimum amount of care, the appearance will last almost indefinitely. Unlike plating or coatings, there is nothing to peel off or wear away that would allow corrosion underneath.

The actual appearance may not be exactly like new chrome in either the degree of luster or color. There may be fine polishing lines visible up close and small differences between mating parts of an assembly. A grille guard, for instance, may have small differences between the round tubing and the flat plate. The backside of a part may not be as highly polished as the front. However, part of the beauty and appeal of stainless actually lies in the smooth “hand-worked” appearance.

There also is a possibility that small rust spots can appear on stainless products. They are usually due to minor iron contamination on the surface as a result of normal manufacturing and handling processes. This minor rust, if it occurs at all, is easy to remove and will not tend to spread.

**Recommended care:**

Regular washing with fresh water and mild car wash detergents followed by rinsing and drying with a soft towel is the best minimum care. Beyond that, any cleaner/wax recommended for automotive finishes will work well to remove minor stains and scuffs, enhance the shine and provide protection. Always use clean soft cotton cloths. In most cases, this will be all that is required for many years. For more serious blemishes or a rust spot, use a cream metal polish recommended for stainless, aluminum, etc. Try to rub in the direction of the original polishing lines.

Ultimately, any stainless part can be restored to a brilliant shine with power buffing processes.

**▲ CAUTION**

Do not use steel wool or any type of metal scraper. Do not use “Scotch Brite” pads or abrasive powdered cleaners. Do not try to clean with muriatic acid or any other acid.

**Stainless Fasteners**

Stainless steel fasteners are included in many of the stainless kits. These fasteners provide similar corrosion resistance and appearance as the rest of the kit. However, stainless fasteners are prone to galling when installed in similar stainless material. It is a good idea to apply a small amount of anti-seize compound to the threads when installing them. Care should also be taken when tightening the fasteners to prevent rounding or deforming the corners of the bolts. Make sure the wrenches are the correct size and fit properly. In the case of socket heads, the wrench should have sharp, un-worn edges. With a few precautions during assembly the products should provide years of service.

© 2011 Copyright Warn Industries, Inc. All rights reserved.

**CARELESS INSTALLATION AND OPERATION CAN RESULT IN SERIOUS INJURY OR EQUIPMENT DAMAGE. READ AND UNDERSTAND ALL SAFETY PRECAUTIONS AND OPERATING INSTRUCTIONS BEFORE INSTALLING AND OPERATING THIS PRODUCT.**

