



INSTALLATION INSTRUCTIONS

WARN Rock Sliders- TJ Unlimited

As you read these instructions, you may see **NOTES**, **CAUTIONS** and **WARNINGS**. Each message has a specific purpose. **NOTES** are additional information to help you complete a procedure. **CAUTIONS** are safety messages that indicate a potentially hazardous situation which, if not avoided, may result in minor or moderate injury. A **CAUTION** may also be used to alert against unsafe practice. **WARNINGS** are safety messages that indicate a potentially hazardous situation, which, if not avoided could result in serious injury. **CAUTIONS** and **WARNINGS** identify the hazard, indicate how to avoid the hazard, and advise of the probable consequence of not avoiding the hazard. **PLEASE WORK SAFELY!**

NOTE: This installation requires some drilling. Holes will need to be drilled through the side and bottom of the vehicle body.

General Information:

- Fits all 05 Jeep TJ Unlimited Wranglers.
- Will not fit with other aftermarket body side parts.
- Factory steps may need to be removed to allow for clearance of rock slider.

Step by Step Instructions:

1. Thoroughly clean both sides of vehicle under the doors. Remove any factory or aftermarket steps or side plates.
2. Using a tape measure, place a couple of marks on the side of the vehicle, 5.75" up from the bottom of the body. **Note:** This will be where the top of the rock slider should be once installed.

- Carefully place one of the rock sliders on the side of the vehicle. Position the rock slider vertically by using the marks from the previous step. Align front to back using the fender flares. **Note:** Because of the wide variety of fender flares, the rock sliders may have a slight gap to the flares. The vertical position is also related to the flares. If the flares do not allow the rock slider to be positioned to the 5.75" vertical measurement, loosen the flares and move them slightly, to allow the rock slider to move down to the 5.75" measurement. **See Figure 1.**

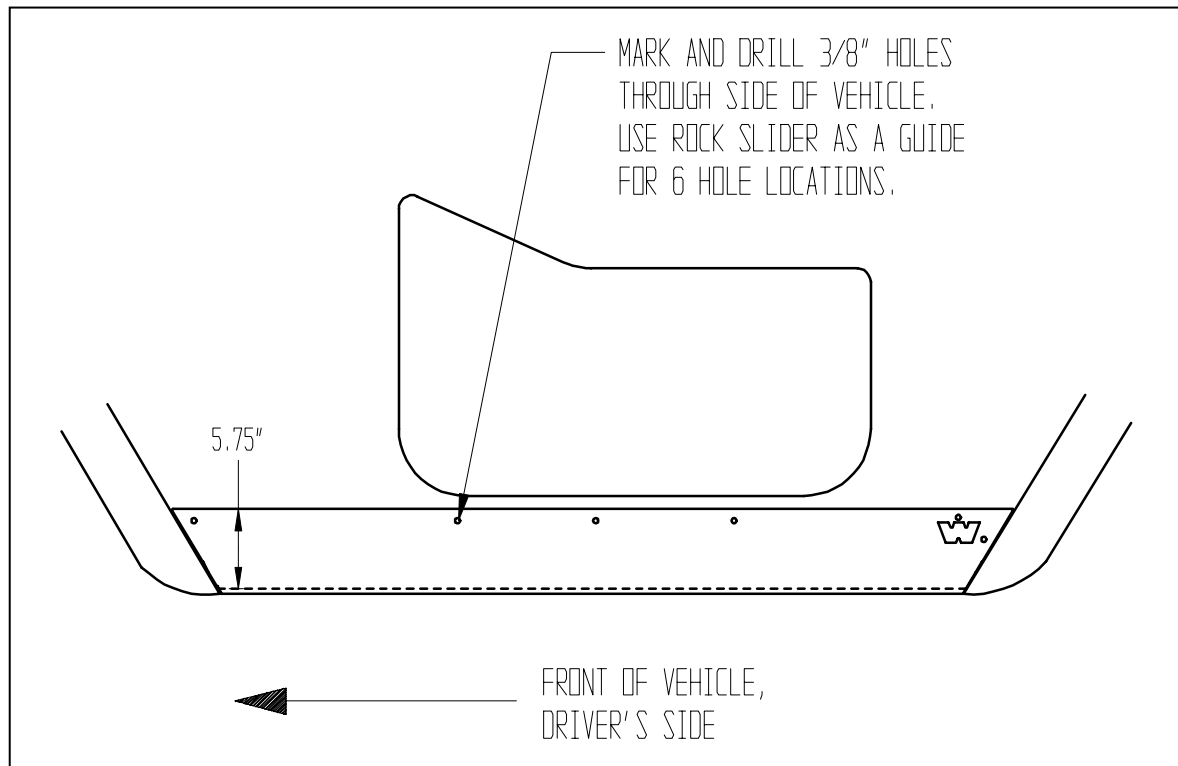

Figure 1, Driver's Side View

- Once the rock slider is in the correct position, mark the six side holes, using the rock slider as a guide. Open the door and check for any factory wires and carpeting that may be on the backside of the drilling locations. If there are wires or carpeting in these locations, move them out of the way temporarily. Remove the rock slider and drill the six side holes to 3/8". Clean any drill chips off the side of the vehicle.



WARNING



Drilling operations can cause flying metal chips. **WEAR SAFETY GOGGLES.** Flying metal chips can cause eye injury.

5. Once the side holes are drilled and cleaned, place the rock slider back on the side of the vehicle. Using the supplied 3/8" black button head bolts, insert the bolts through the rock slider and the side of the vehicle. Place a 3/8" flat washer and lock nut on each bolt and torque to 30-36 ft/lbs. Re-tighten the fender flares if they were loosened.
6. Repeat steps 2-5 for the opposite side of the vehicle.
7. On the inside of the vehicle, pull the carpet up and away from the doorsill and the floor on both sides of the vehicle. Check for any wiring that may be under the carpet and move it out of the way temporarily. Using a drill and 3/8" bit, drill the three bottom holes on each side, using the bottom of the rock slider as a guide. Be careful not to drill into the carpet or any wiring that may be present.



WARNING



Drilling operations can cause flying metal chips. **WEAR SAFETY GOGGLES.**
Flying metal chips can cause eye injury.

8. Install the supplied spacer tubes between the rock slider and the floor. The four short spacer tubes are located in the front and rear locations on both sides. The two long spacer tubes are located in the middle position on both sides. **Note:** Due to variations in vehicle manufacturing, it may be necessary to place a washer on the spacer tube if there is an excessive gap.
9. Using the supplied hardware, insert the 3/8" x 2.25" bolts with a flat washer in the front and rear locations. Install a 3/8" flat washer and 3/8" nyloc nut on each bolt. Insert the 3/8" x 3.5" bolts with a flat washer in the middle locations. Install a 3/8" flat washer and 3/8" nyloc nut on each bolt. It is up to the installer if the bolts should be going up or down. Torque the 3/8" bolts to 30-36 ft/lbs.
10. Place any moved carpet or wiring back to its original position.