



# INSTALLATION INSTRUCTIONS

## Trans4mer Grille Guard/Winch Mount For Chevrolet Silverado 1500HD & 2500 Kit 68162

This WARN Trans4mer system can be customized to give your Chevy Silverado a wide variety of looks, front-end protection and winch mounting capability. The system starts with this strong two-tube grille guard that attaches to the truck's frame with brackets designed to handle up to a 15000 lb. winch. It is durable and good looking as a stand-alone grille guard, but can be easily upgraded with some great options! You can add a third large size tube (light bar) that adds even more protection and includes tabs for mounting auxiliary lights. The tubes can be mounted in a variety of positions to achieve the look and function that you desire. You can mount a winch carrier bracket that provides a permanent mount for a Warn winch. An accent cover is available to dress up the winch carrier. You may also add a receiver bracket that will handle the Warn multi-mount winch system, a draw bar or any other accessory that fits the standard 2-inch receiver tube. Finally, brush guards that protect the headlights and front corners of the truck can be easily added to any of the options above.

### **▲WARNING**

***ALWAYS USE EXTREME CAUTION WHEN DRILLING ON ANY VEHICLE. MAKE SURE THAT ALL FUEL LINES, BRAKE LINES, ELECTRICAL WIRES AND OTHER OBJECTS ARE NOT PUNCTURED OR DAMAGED WHEN/IF DRILLING ON THE VEHICLE. THOROUGHLY INSPECT THE AREA TO BE DRILLED (BOTH INBOARD AND OUTBOARD SIDE OF FRAME) PRIOR TO DRILLING, AND RELOCATE ANY OBJECTS THAT MAY BE DAMAGED. FAILURE TO INSPECT THE AREA TO BE DRILLED MAY RESULT IN VEHICLE DAMAGE, ELECTRICAL SHOCK, FIRE, OR PERSONAL INJURY.***

### **▲WARNING**

***ALWAYS COMPLETE EVERY STEP OF THE INSTRUCTIONS AS SPECIFIED. NOT DOING SO MAY RESULT IN VEHICLE DAMAGE, PERSONAL INJURY, OR DEATH.***

### **▲WARNING**

***ALWAYS WEAR SAFETY GLASSES WHEN INSTALLING THIS KIT.***

### PARTS LIST

<u>PART NO.</u>	<u>QUANTITY</u>	<u>DESCRIPTION</u>
68063	2	Side Member, Black
29366	2	Grille Guard Tube, Black
29147	4	Washer, Plastic
65234	1	Frame Extension, RH
65235	1	Frame Extension, LH
65237	1	Y-Plate
65278	2	Support Plate
65276	1	Upper Bracket, RH
65275	1	Upper Bracket, LH
65190	2	Y-Plate Spacer
38782	4	Clamping Strap
68034	1	Strap Assy, RH
68035	1	Strap Assy, LH
67963	1	Front Plate
67964	1	Back Plate
62113	2	Nut w/Handle
13222	2	Tow Hook, Black

## TORQUE SPECIFICATIONS

BOLT SIZE	TORQUE
3/8 inch	30 lb. ft. (40.7 N-m)
7/16 inch	50 lb. ft. (67.8 N-m)
1/2 & 5/8 inch	75 lb. ft. (101.7 N-m)

**NOTE:** This installation requires hole drilling. Make sure you have a drill motor and a sharp 7/16” drill bit available. Wear safety goggles.

**NOTE:** Follow the instructions step by step for fastest installation. Do not securely tighten fasteners until directed to do so.

(A) Remove the grille and bumper. The grille must be removed first to gain access to the bumper bolts. These are easy to remove if the following procedure is followed:

- Open the hood. Remove the plastic fasteners that attach the plastic shroud to the top of the grille. Pry up the center pin with a screwdriver, and then pry out the collar.
- There are 6 clips holding the grille in place. First give a sharp pull at each of the four corners of the grille to release the clips. Then give a sharp pull at the extreme outer ends of the grille to release the other 2 clips. Remove grille.
- Unplug the fog lights from the bumper, if so equipped.
- Remove the bolt from the outer bumper braces just forward of the wheels (15mm head) on both sides.
- Remove the four remaining bumper bolts (15mm head) and remove bumper.

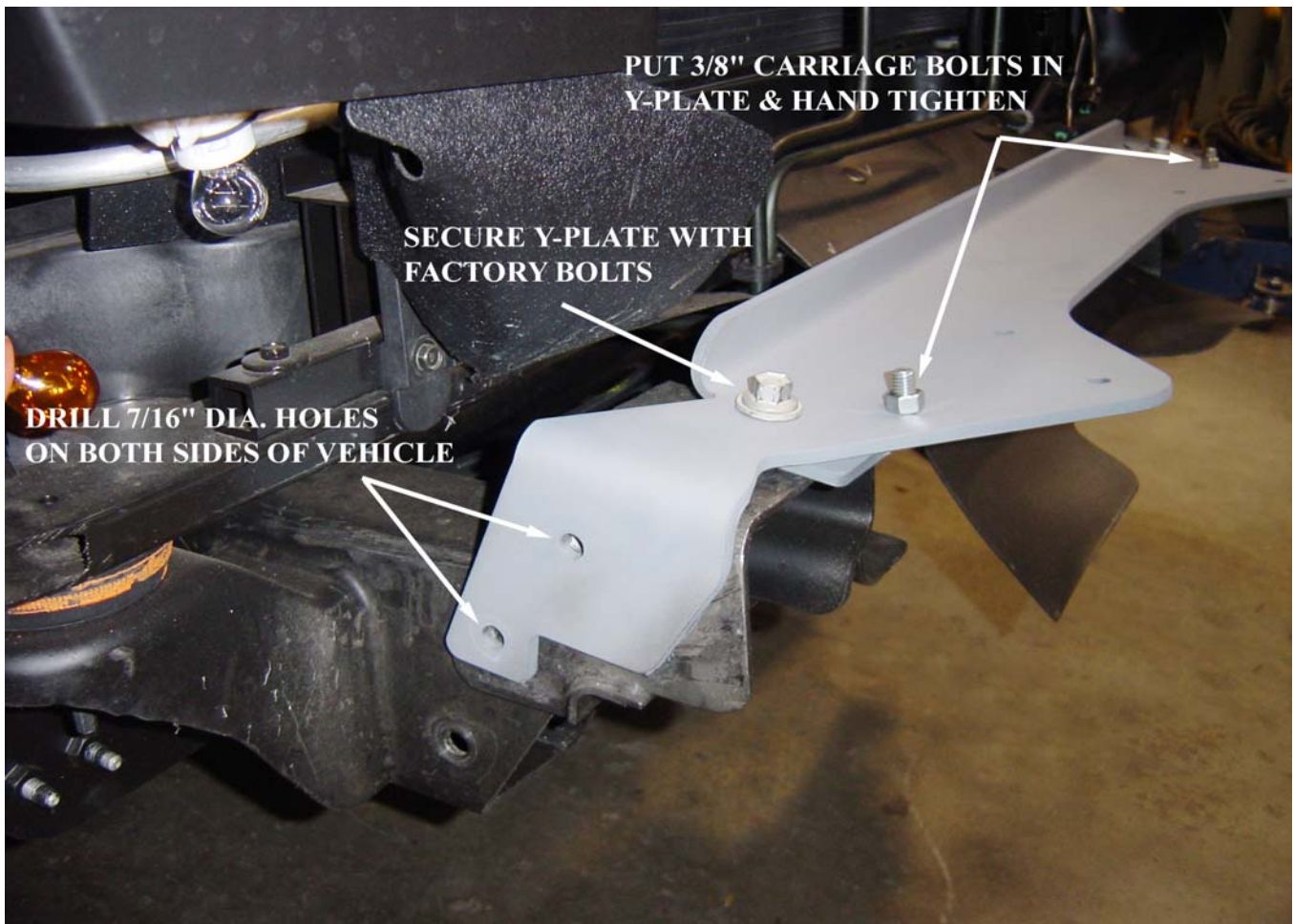
(B) Remove the tow hooks. Remove front license plate and bracket if so equipped.

- Place the Y-Plate Spacer then the plain Steel Spacer on top of the frame towers where the upper bumper brackets mount (refer to **Figure 1**). NOTE: The plain Steel Spacer is the exact thickness of the bumper.



**Figure 1: Place spacers on frame for drilling.**

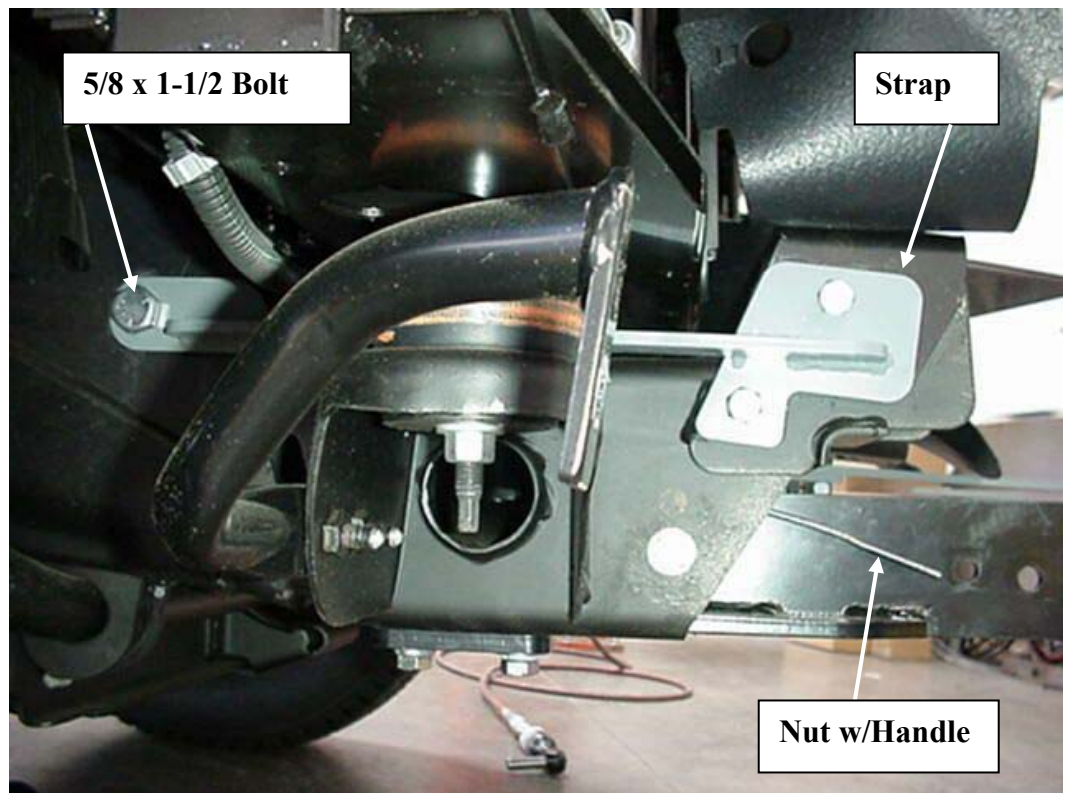
- Put the 3/8” carriage bolts into the square holes on the Y-Plate from the bottom side. Loosely attach with nuts. NOTE: This will make installation of the upper brackets easier.



**Figure 2: Drill mounting holes for Y-Plate.**

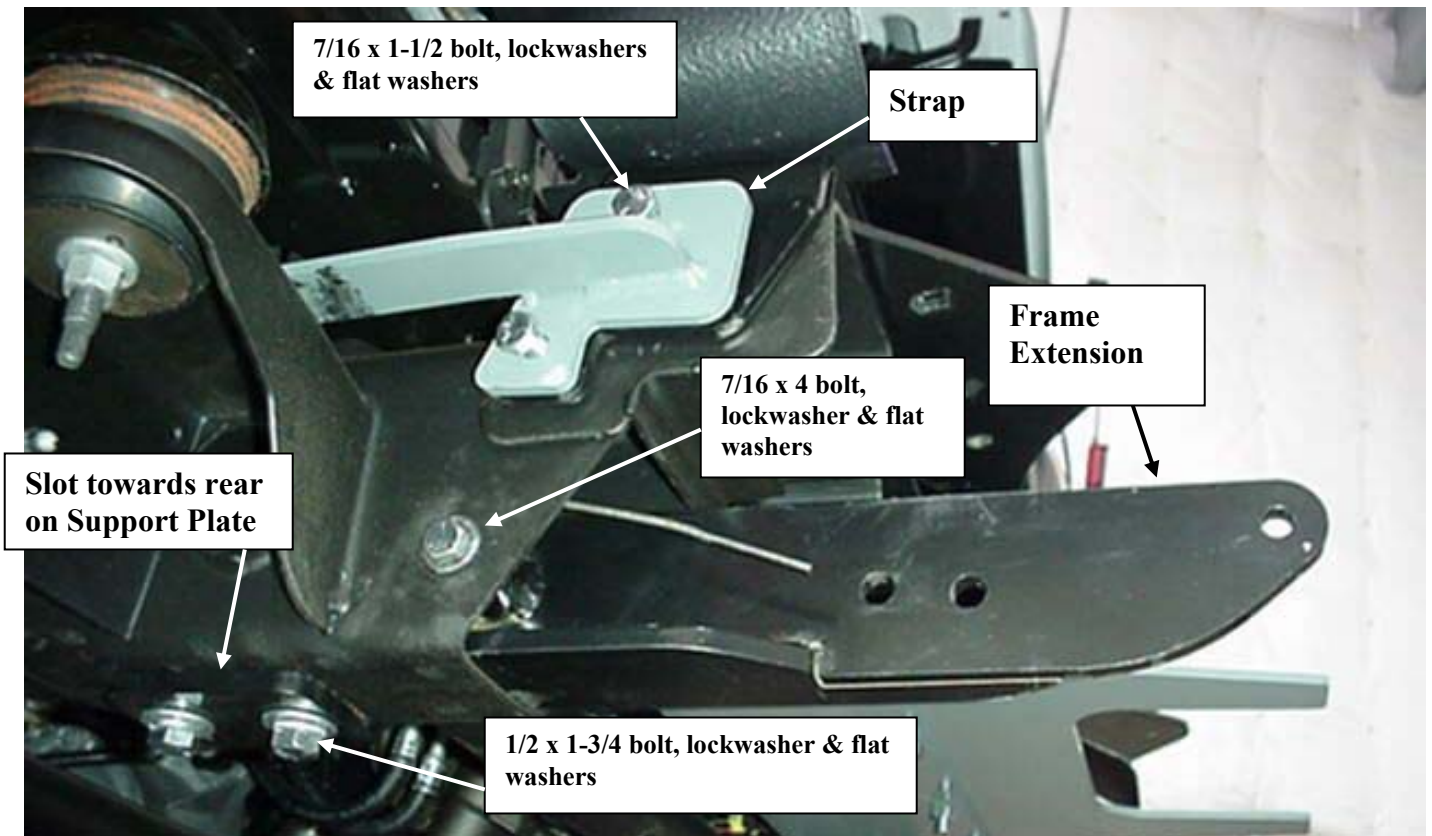
3. Mount the Y-Plate to the frame towers as shown in **Figure 2**. Use the holes on the sides of the Y-Plate to drill the 7/16 holes in the frame and frame towers. Remove the Y-plate.

4. Loosely install the Straps with the 5/8" x 1-1/2" bolt and the Nut w/ Handle. The front holes of the strap will share the holes drilled in step 3. The Nut w/ Handle slides into the front of the frame.



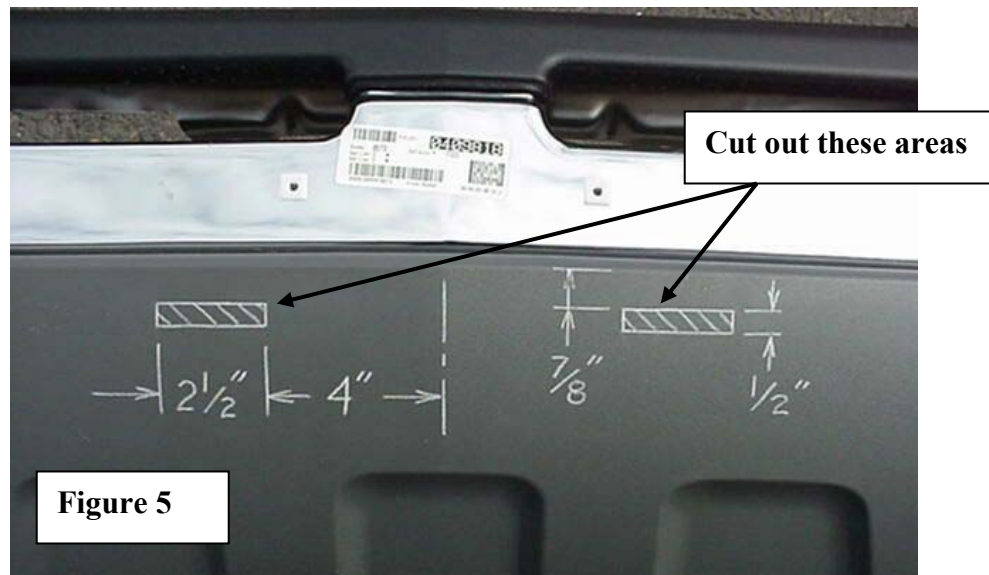
**Figure 3: Loosely attach strap.**

WARN

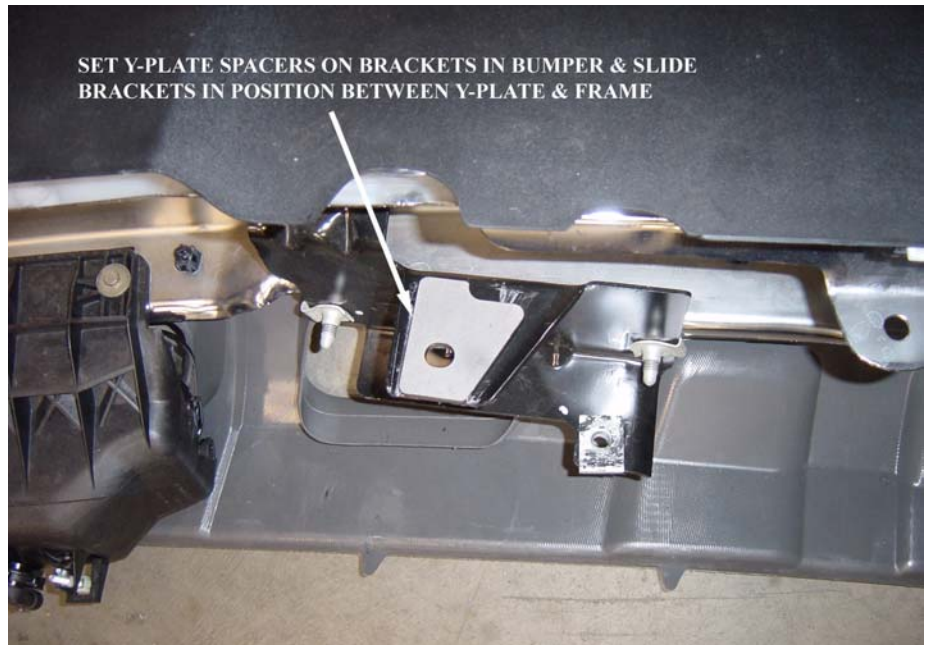


**Figure 4: Install Frame Extension.**

5. Reinstall the Y-Plate without the spacers and only attach it and the Strap with one 7/16"x 1-1/2" bolt, lock washer and nut on each side. Do not tighten the bolt all the way. Install the Frame Extension as shown in **Figure 4**. Use the Support Plates underneath the frame with the slots towards the rear of the vehicle. NOTE: Use flat washers on both sides of the 7/16"x 4" bolt.
6. Refer to **Figure 5** and make the cutouts in the bumper lower plastic as shown. A suggestion is that holes be drilled in the corners of the cutout, then cut the sides with a small hand saw or Dremel type rotary tool. A sharp knife or Exacto blade works well to do finish trimming.



7. Set the Y-Plate Spacers on the bumper brackets as shown in **Figure 6a**. Slide the bumper into place. The bumper bracket and Spacer slide underneath the Y-Plate. Since there are only two bolts holding the Y-Plate in place it should rotate back slightly to ease installation. Use a screwdriver as shown in **Figure 6b** to help align the holes.



**Figure 6a: Place Y-Plate Spacer on bumper.**

NOTE: WHEN ALIGNING THE HOLES IT IS CONSIDERABLY EASIER IF THE Y-PLATE ONLY HAS ONE BOLT PER SIDE HOLDING IT IN PLACE, AND IF THE BOLTS ARE LOOSE.

Once the holes are aligned, put the six factory bumper bolts back in place, but do not tighten them yet.

8. Remove the nuts from the carriage bolts on the Y-Plate and install the Upper Brackets as shown in **Figure 7**. Use 3/8"x 1" bolts, lock washers, and nuts. NOTE: It may be easier to push the front bolts up from the bottom like the carriage bolts.



**Figure 6b: Use screwdriver to align parts.**



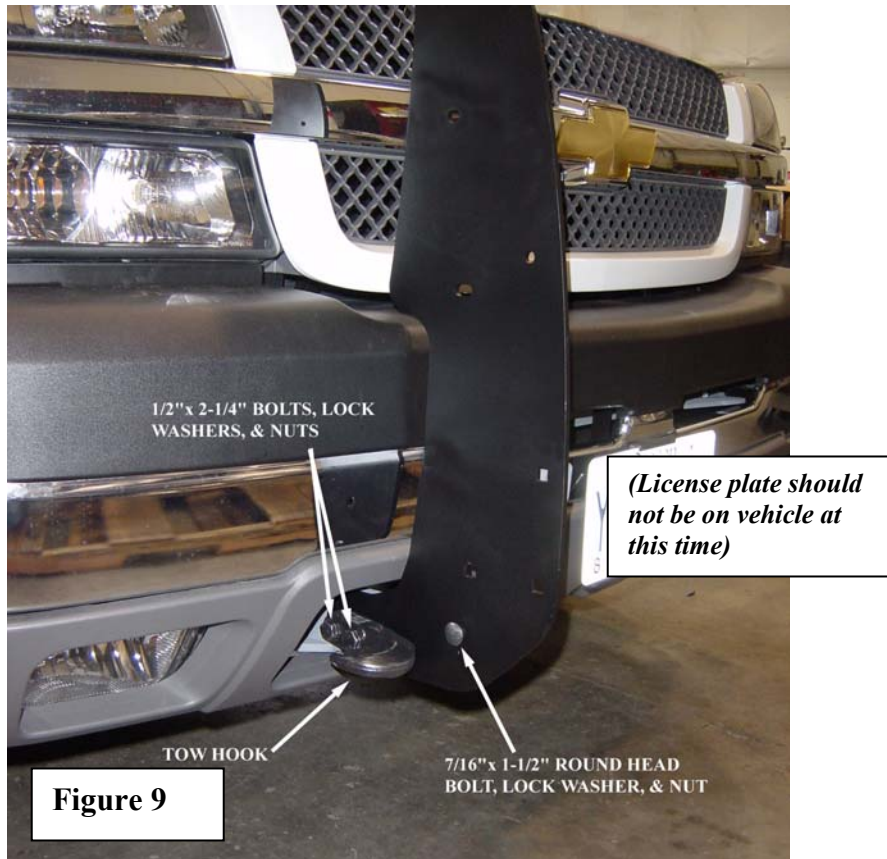
**Figure 7**

9. Carefully center the bumper side to side by checking the match-up to the front fenders on each side. Tighten all six bumper bolts securely. Plug fog lights back in. Reinstall grille.
10. Remove the plastic air deflector panel from the front crossmembers of the vehicle frame. Install the Clamping Straps and the Rear Plate and Front Plate as shown in **Figure 8**. The Front Plate mounts on top of the Rear Plate. The tabs on the Front Plate will protrude forward thru the cutouts in the bumper. (The plates are not required if a winch is not being mounted).



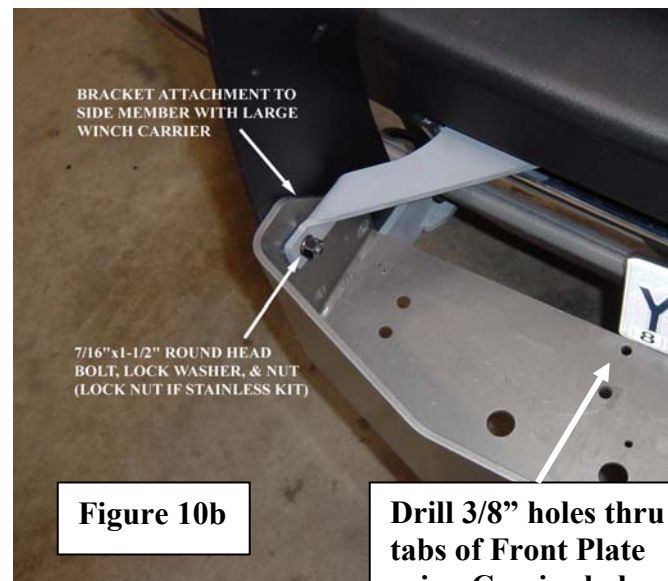
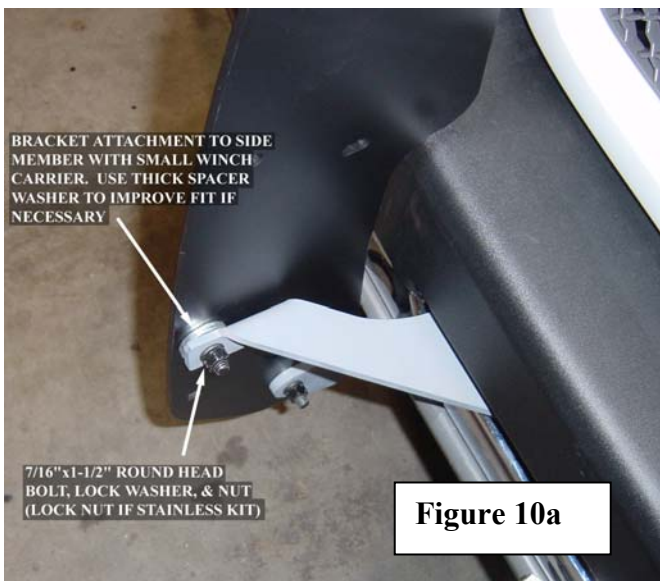
**Figure 8**

11. Install the Side Members onto the Frame Extensions as shown in **Figure 9** and include the Tow Hooks at the inner lower holes. Leave fasteners loose.



12. If a winch carrier is being used, install it at this time. Install the upper Grille Guard Tube. (**Figure 11**).

13. Install the Bracket to the Side Members as shown in **Figure 10a or 10b**, depending on winch carrier type.



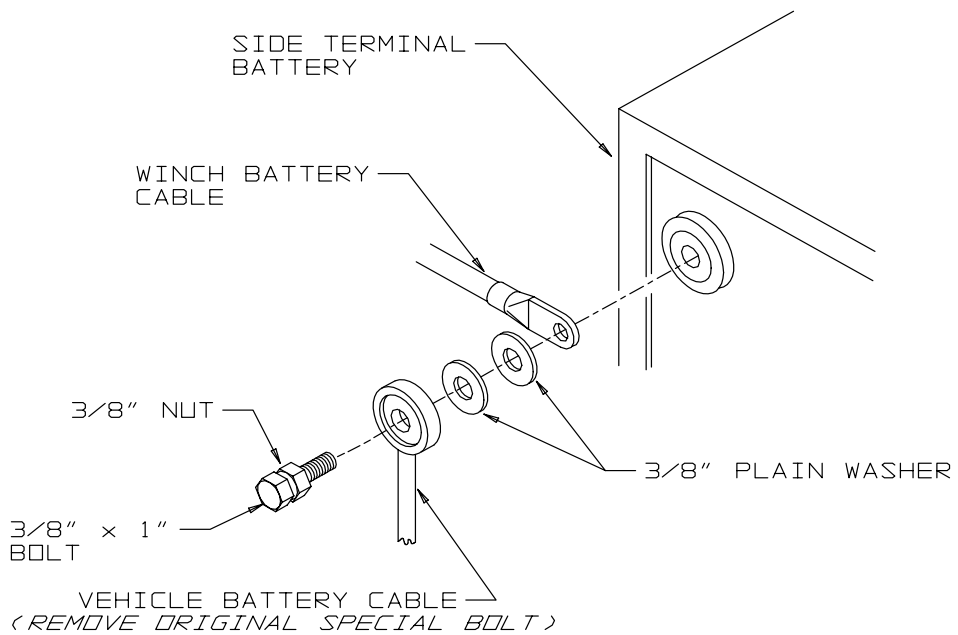
**Drill 3/8" holes thru tabs of Front Plate using Carrier holes as a guide.**

14. When a Winch Carrier is being used, the tabs of the Front Plate should be pushed up against the bottom of the Carrier. Then drill 3/8" holes down thru the tabs using the rear holes in the Carrier as guides. See **Figure 10b**. Use the 3/8" x 1-1/2" bolts furnished with the Carrier to secure the tabs to the Carrier and thread up into the Warn mid-sized winch. If the winch is the large 12 or 15,000 lb. style, use lockwashers and nuts with the bolts to secure the tabs to the Carrier.
15. Tighten all fasteners to specified torque. Reinstall the plastic air deflector panel onto the crossmembers.
16. Install the winch (if applicable) referring to the instructions packaged with the winch.
17. Install the lower Grille Guard Tube as shown in **Figure 11**. Use the plastic washers at the ends of the Tubes.





18. Make the winch electrical connections (if applicable) to the side terminal battery using the supplied hardware shown in **Figure 12**.



**Figure 12**





