



# INSTALLATION INSTRUCTIONS

## RECEIVER Kit 60268

**For Chevrolet and GMC Truck  
Models 2500, 2500H.D. and 3500**

**NOTE: This installation requires hole drilling. Make sure you have a drill motor and a sharp 1/2" drill bit available. Wear safety goggles.**



### **WARNING**

Drilling operations can cause flying metal chips. **WEAR SAFETY GOGGLES.** Flying metal chips can cause eye injury.

### **BOLT SIZE**

12mm

### **TORQUE SPECIFICATIONS**

58 lb. ft (78.6 N-m)

**NOTE: Follow the step by step sequence for fastest installation. Do not securely tighten bolts until directed.**

1. Refer to **Figure 1-A, 1-B** and **1-C** and find the bumper lower plastic area that looks most like your truck. Trim lower plastic piece as described, cutout to be centered from side to side in bumper. Some additional trimming may be required as shown in **Figure 1-D**.

**CHEVROLET**

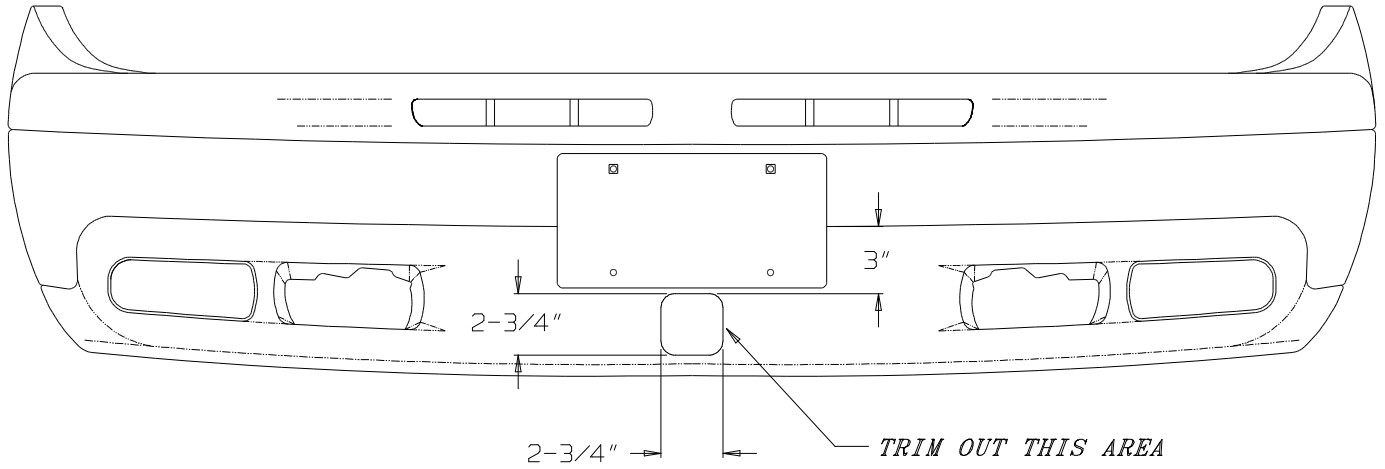

**FIGURE 1-A**

**GMC**

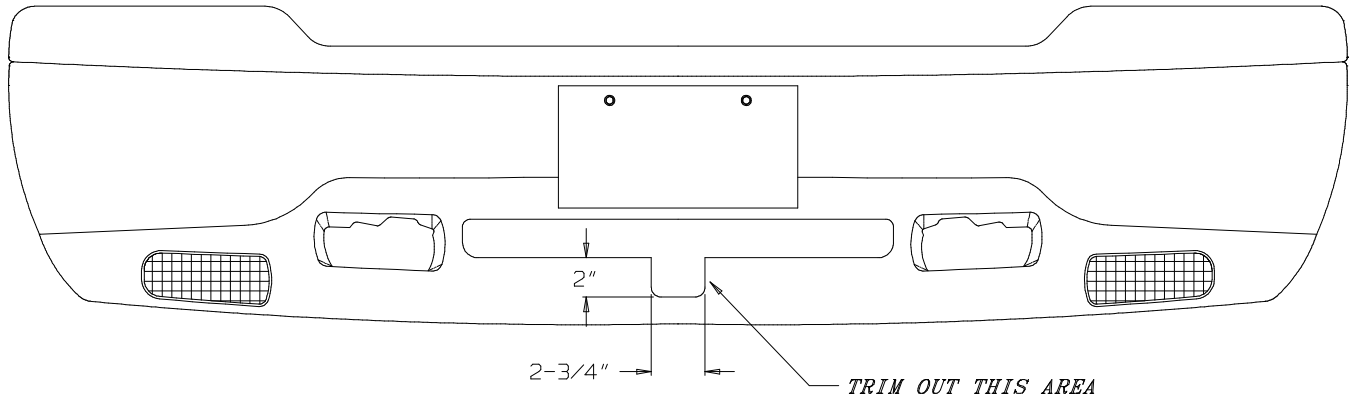

**FIGURE 1-B**

**CHEVROLET**

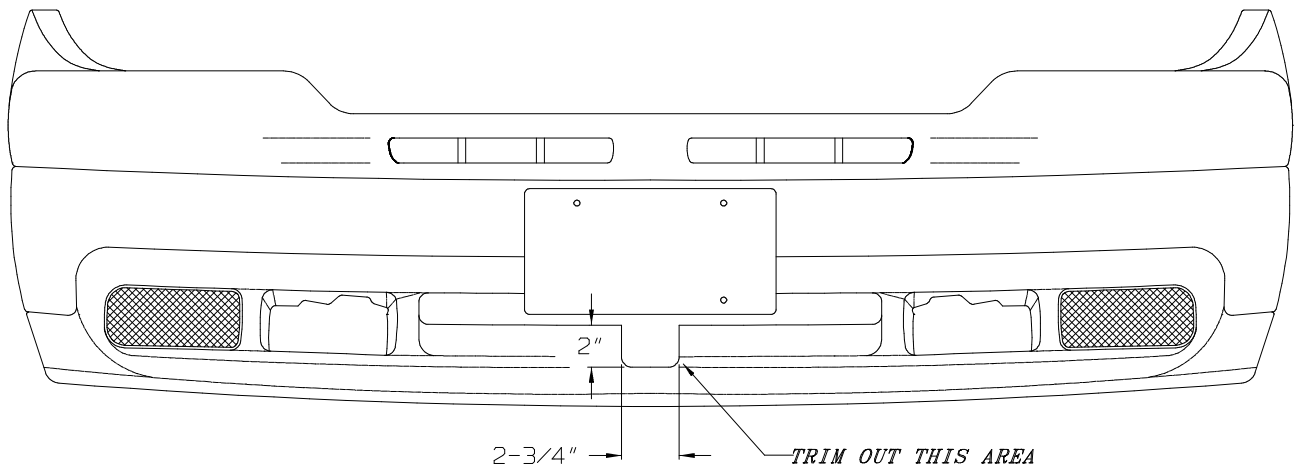

**FIGURE 1-C**

**FIGURE 1-D**



2. Remove the lower and inner tow hook bolts, then loosen the outer tow hook bolt so the tow hook may move freely as shown **figure 2**, both sides.

**FIGURE 2**

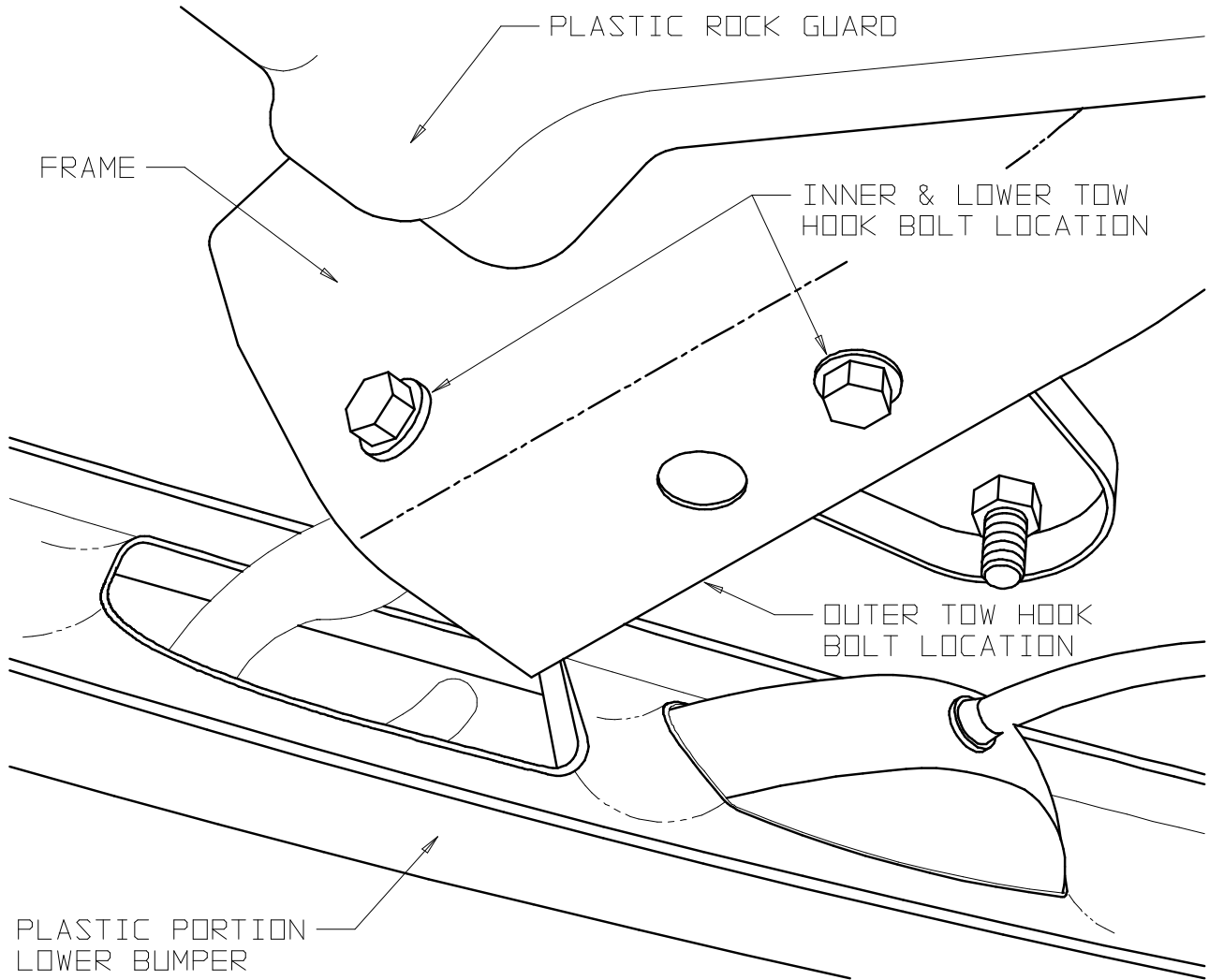

3. Lift Receiver into position as shown in Figure 3. Install the fasteners at the rear most location first and lightly tighten. Be sure the receiver is centered side to side, then install the spacer washers and 40mm bolt. Drill 1/2" hole using receiver as a guide, then install 12mm x 35mm bolt. Install the 1/2" lock washer & 12mm nut through tow hook opening in bumper. Tighten all fasteners to the proper torque specification.

**FIGURE 3**

