



# INSTALLATION INSTRUCTIONS

## Winch Mounting Kit 37170 for Jeep Wrangler TJ

Compatible with Standard Bumper or Mopar Accessory Tube Bumper.  
Refer to Step #6 if vehicle is equipped with factory tow hooks.

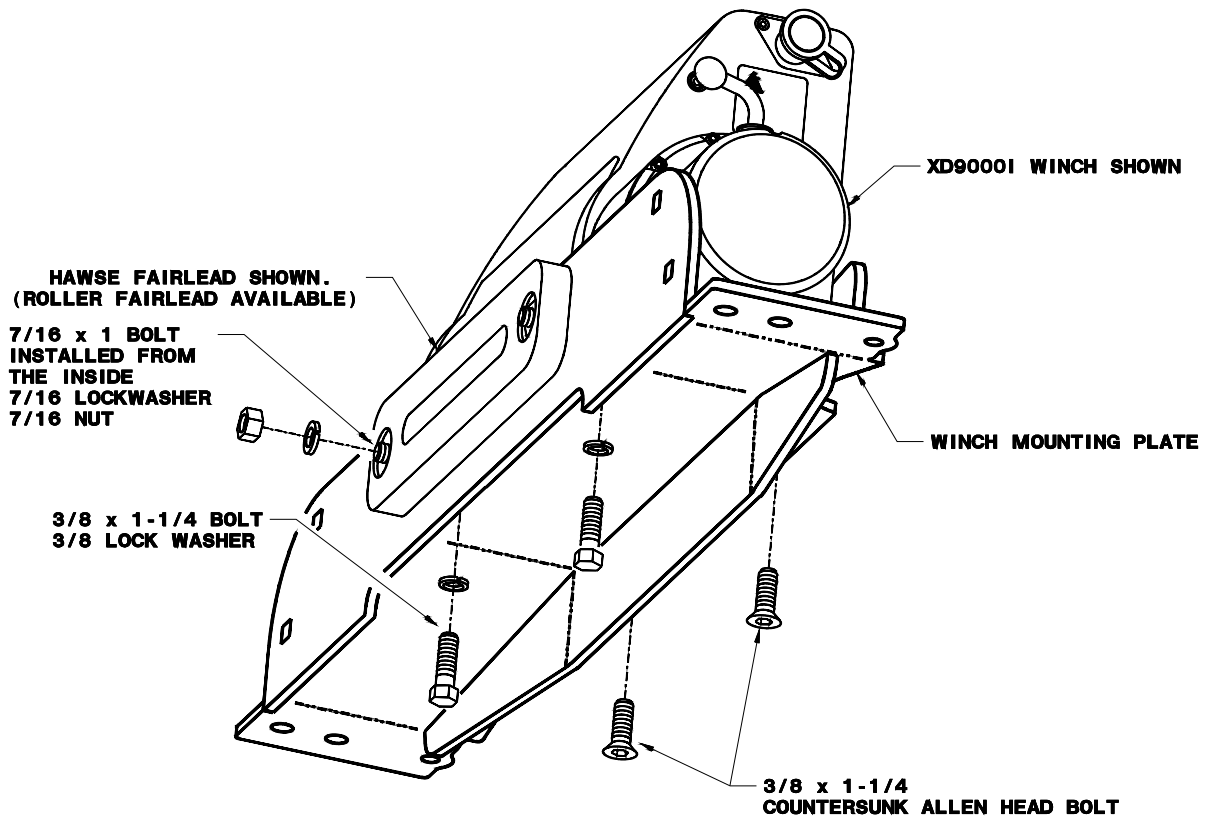
### Parts List

<u>Part No.</u>	<u>Quantity</u>	<u>Description</u>	<u>Torque</u>
37075	1	Winch Mounting Plate	
26368	1	Solenoid Bracket	
11075	4	Square Plastic Hole Plug	
	4	1/2-13 x 1-1/2 Torx Bolt	75lb/ft(102N-m)
	2	3/8-16 x 1-1/4 Ctrs'k Allen Bolt	31lb/ft(42N-m)
	2	M10 x 1.50 x 35mm Bolt	32lb/ft(43N-m)
	8	M10 Flat Washer	
	1	5/16-18 x 1-1/4 Allen Bolt	17lb/ft(23N-m)

Following fasteners are packaged with winch:

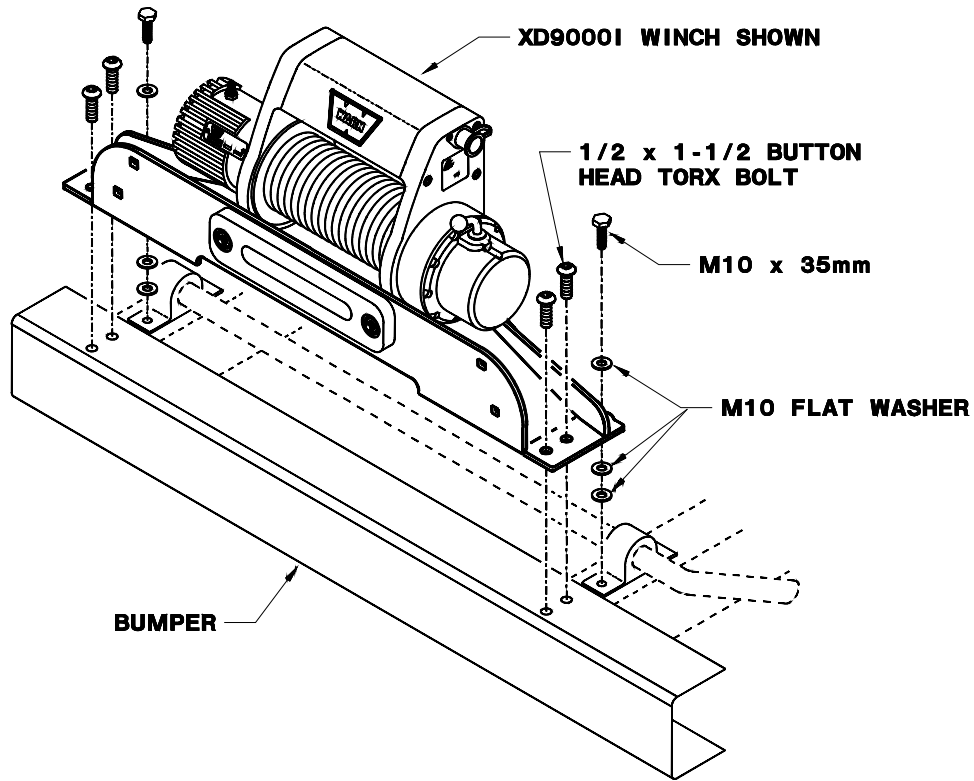
4	3/8-16 Square Nut	
4	3/8-16x1-1/4 Hex Bolt	31lb/ft(42N-m)
4	3/8 Lockwasher	
2	7/16-14x1 Hex Bolt	50lb /ft(68N-m)
2	7/16-14 Nut	
2	7/16 Lockwasher	

1. The winch, fairlead, and mount plate must be subassembled together before assembly to vehicle begins. **(Figure 1)**. First, install fairlead onto plate with the bolts inside out, that is, with the bolt heads near the winch and the lockwashers and nuts against the fairlead. Next, place square nuts into pockets in mounting feet of winch and install the winch onto the plate. At the rear winch mounting holes, use the countersunk allen head bolts. At front holes, use hex bolts with lockwashers. Tighten securely.



**FIGURE 1**

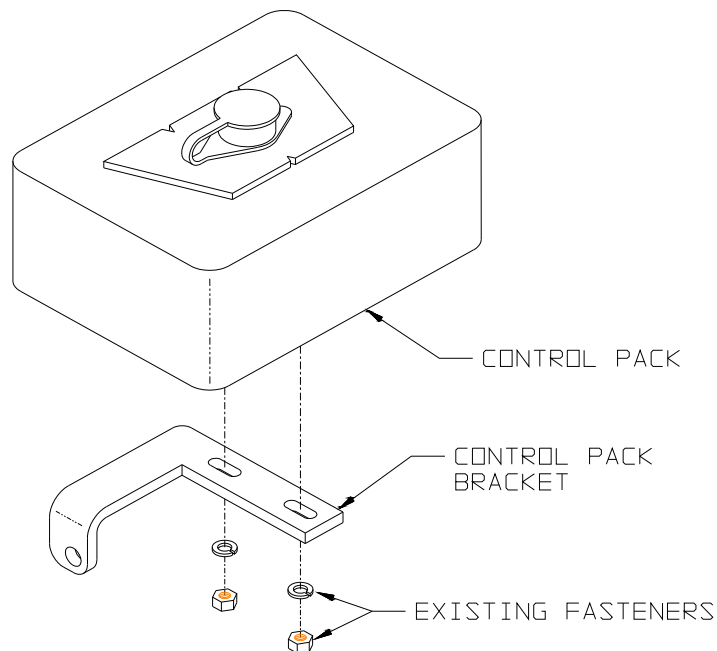
2. Remove the plastic shroud located just forward of the vehicle grille. If vehicle has factory fog lights mounted on bumper, relocate lights outboard.
3. Remove the two Torx head bumper bolts on each side. Some vehicles may have the factory optional tow hooks mounted here. (See Step #6). Remove the forward bolt of each stabilizer bar bracket.
4. Place two or three flat washers on each stabilizer bar bracket to act as spacers. Place the winch bracket with winch down onto the bumper and spacer washers. **(Figure 2)**. Secure with the supplied 35mm hex head bolt and a flat washer at the rear holes. Use the supplied Torx head bolts at the front holes. **Warn tow hooks can be mounted at the front holes, but longer bolts are necessary.** Use minimum Grade 5 bolts and verify full engagement into frame retainer threads with winch plate in place.

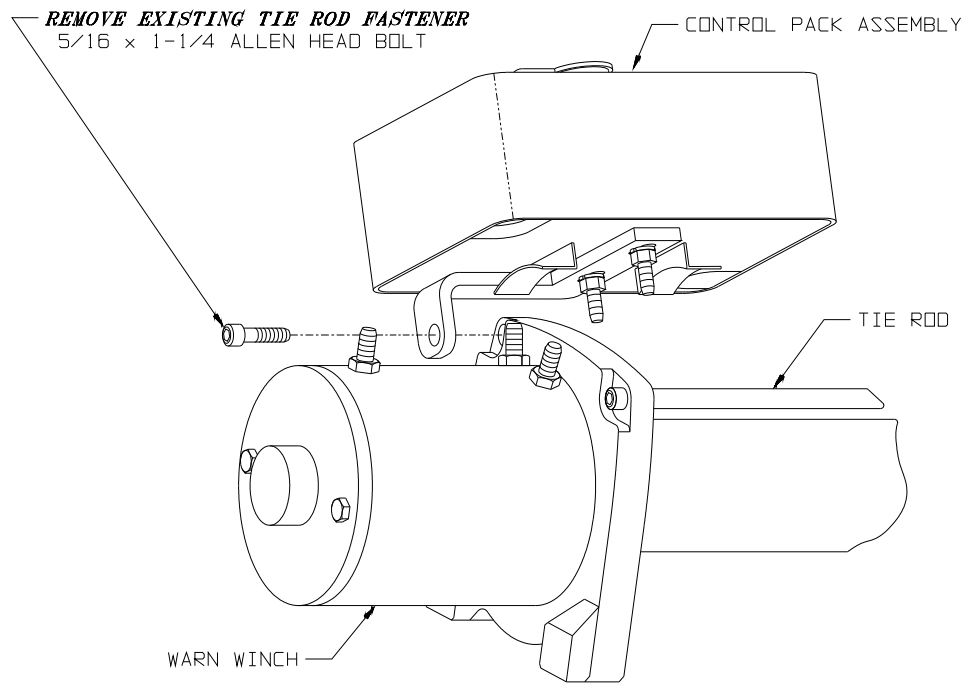


**FIGURE 2**

5. Refer to the winch Installation Instructions and complete the winch installation and electrical connections to the battery. If the winch has the separate black solenoid control box, mount it to the winch with supplied bracket as shown in **Figure 3** and **Figure 4**.

**FIGURE 3**





**FIGURE 4**

6. If vehicle is equipped with factory tow hooks, the choices are:
  - a. Remove and save for possible future use, or
  - b. Replace driver side hook on passenger side and passenger side hook on driver's side. Longer attaching bolts may be necessary. Verify full engagement into frame retainer threads with winch plate in place.
7. A tubular Grille Guard, part number 37171, is available from Warn dealers. It mounts to the square holes on the front of the winch mounting plate. If the grille guard is not used, push the square plastic hole plugs into the holes.