



INDUSTRIAL

WARN DC3000LF & HYD3000LF

ELECTRIC and HYDRAULIC HOIST

INSTALLATION and OPERATORS GUIDE

**THIS MANUAL MUST ACCOMPANY HOIST AND BE WITHIN EASY ACCESS OF
HOIST OPERATOR.**

A NEW HOIST OPERATOR MUST READ AND UNDERSTAND THIS MANUAL.

Warn Industries, Inc.
12900 SE. Capps Road • Clackamas, Oregon 97015 • USA
503.722.1200 • International Fax: 503.722.3005



Table of Contents

Introduction & Owner Information	2	Electric & Hydraulic Operating Instructions	14
Product Features	3	Maintenance	16
Safety Precautions	4	Troubleshooting Guide	17
Electric Winch Data	6	Replacement Parts list	20
Hydraulic Winch Data	7	Warranty Statement	22
Hoist Installation	8		
Hydraulic Information	12		

Introduction

Dear Customer:

Congratulations on your purchase of a new WARN 3000LF HOIST.

We are delighted to have you as a customer and want to make sure that your experience with Warn is a positive one.

The information in this manual helps insure that your Warn hoist is installed properly and operated safely. Although we believe the manual is complete and understandable, it is not a definitive guide to every possible situation or circumstance.

To avoid hazardous situations, every operator must be knowledgeable of appropriate safety guidelines, codes and regulations relating to rigging, rope and winch usage. Remember that an uninformed or careless operator can make the operation of any equipment dangerous.

Ultimately the owner/operator must make the final decision as to how this product will be, mounted, used and whether that intended use is safe.

If, after reading this manual, you have any questions - please call us. At Warn, we pride ourselves on customer service and product support.

For future reference, please record the following information:

Model/Part Number: _____ **Date of Purchase:** _____

Sincerely,

Your WARN Industries Customer Service Team

United States:

Phone: 503.722.1200 or (800) 543-9276 (US only)

Fax: 503.722-3000

International:

Phone: 503.722.3008

Fax: 503.722.3005



Product Features

THE DC3000LF and HYD3000LF HOISTS WERE DESIGNED SPECIFICALLY TO MEET THE NEEDS OF THE TRUCK MOUNTED CRANE INDUSTRY. THEY ARE EXCELLENT TOOLS FOR LIFTING AND LOWERING LOADS IN MOBILE APPLICATIONS.

Key Features

DC3000LF:

- **3-stage planetary gear train:** *Heavy duty and permanently lubricated for maximum efficiency and service life.*
- **Large diameter drum:** *Meets ANSI B30.5 specifications for drum to wire rope ratio.*
- **Wedge and pocket rope anchor system:** *Easily and securely anchors rope to drum.*
- **Two separate braking systems:** *A load applied brake and a dynamic electric braking system assure safe hoist operation.*
- **Heavy-duty series-wound motor with thermal protection switch**
- **Heavy-duty controller:** *Industrial contactor technology designed for rugged, outdoor operation.*
- **Heavy-duty, detachable, 12 ft. (3.7m) long, remote control pendant**

HYD3000LF:

- **Two stage planetary gear train:** *Heavy duty and permanently lubricated for maximum efficiency and service life.*
- **Large diameter drum:** *Meets ANSI B30.5 specifications for drum to wire rope ratio.*
- **Wedge and pocket rope anchor system:** *Easily and securely anchors rope to drum.*
- **Two separate braking systems:** *A load applied brake and hydraulic dynamic braking assure safe hoist operation.*
- **Heavy-duty high torque hydraulic motor**

Additional Accessories

WARN INDUSTRIAL OFFERS MANY ACCESSORIES TO INCREASE THE VERSATILITY AND PERFORMANCE OF YOUR WARN INDUSTRIAL HOIST. CONTACT YOUR WARN INDUSTRIAL DISTRIBUTOR OR CALL THE FACTORY DIRECT FOR INFORMATION.

- **Industrial wire rope:** *5/16 inch EIPS wire rope with safety hook, 25, 40, 50, 75, 100 ft. (7.6, 12.2, 15.2, 22.9, 30.5m) lengths.*
- **Programmable limit switch:** *Allows hoist operator to easily set upper and lower limits of travel.*
- **ECL:** *Electronic current limiter helps to prevent overloading of the hoist.*



Mechanical Brake

Care must be taken to avoid overheating the mechanical brake. As the load is increased, the duration of brake use must be reduced to limit the brake temperature. Allow adequate time for the brake to cool between uses. The smoothness of operation of the mechanical brake will improve as it is broken in during initial use. **OVERHEATING THE MECHANICAL BRAKE MAY RESULT IN PERMANENT DAMAGE TO, OR FAILURE OF, THE BRAKE. REPLACE ANY DAMAGED BRAKE COMPONENTS BEFORE RESUMING USE OF THE HOIST.**

ALWAYS and NEVER'S of Safe Operation of Winches

The following are the ALWAYS's and NEVER's for safe operation of winches. Taking precedence over any specific rule listed here, however, is the most important rule of all—**USE COMMON SENSE.**

A few minutes spent reading these rules can make an operator aware of dangerous practices to avoid and precautions to take for his own safety and the safety of others. Frequent examinations and periodic inspections of the equipment as well as conscientious observance of safety rules may save lives as well as time and money.

Your safety, and the safety of others, is very important. To help you make informed decisions about safety, we have provided installation and operating instructions and other information on labels on the product. This information alerts you to potential hazards that could hurt you or others. It is not possible to warn you about all potential hazards associated with this product, you must use your own good judgment.

CARELESS HOIST INSTALLATION AND OPERATION CAN RESULT IN SERIOUS INJURY OR EQUIPMENT DAMAGE. READ AND UNDERSTAND ALL SAFETY PRECAUTIONS AND OPERATING INSTRUCTIONS BEFORE INSTALLING AND OPERATING THIS PRODUCT.

This guide identifies potential hazards and has important safety messages that help you and others avoid personal injury or death. **WARNING** and **CAUTION** are signal words that identify the level of hazard. These signal words mean:

WARNING signals a hazard that *could* cause serious injury or death, if you do not follow recommendations.

CAUTION signals a hazard that *may* cause minor to moderate injury, if you do not follow recommendations.

This guide uses **NOTICE** to call attention to important mechanical information, and **Note**: to emphasize general information worthy of special attention



WARNING



MOVING PARTS ENTANGLEMENT HAZARD

Failure to observe these instructions could lead to severe injury or death.

To avoid injury to hands or fingers.

- **Always** keep hands clear of wire rope, hook loop, hook and fairlead opening during installation, operation and when spooling in or out.
- **Always** use extreme caution when handling hook and wire rope during spooling operations.
- **Always** use supplied hook strap whenever spooling wire rope in or out, during installation or operation to avoid injury to hands or fingers.

WARNING



FALLING OR CRUSHING HAZARD

Failure to observe these instructions could lead to severe injury or death.

- **Never** use to lift or move persons.

WARNING



CHEMICAL AND FIRE HAZARD

Failure to observe these instructions could lead to severe injury or death.

- **Always** remove jewelry and wear eye protection.
- **Never** lean over battery while making connections.
- **Always** verify area when drilling is clear of fuel lines, fuel tank, brake lines, electrical wires, etc
- **Never** route electrical cables:
 - Across any sharp edges.
 - Through or near moving parts.
 - Near parts that become hot.
- **Always** insulate and protect all exposed wiring and electrical terminals.
- **Always** install terminal boots as directed in installation instructions.

CAUTION

MOVING PARTS ENTANGLEMENT HAZARD

Failure to observe these instructions could lead to minor to moderate injury.

General Safety:

- **Always** Know Your Winch: Take time to fully read and understand the included Installation and Operations guide, and Basic Guide to Winching Techniques, in order to understand your winch and the winching operation.
- **Never** operate this winch if you are under 16 years of age.
- **Never** operate this winch when under the influence of drugs, alcohol or medication.
- **Never** exceed winch or wire rope rated capacity. Double line using a snatch block to reduce winch load.

Installation Safety:

- **Always** choose a mounting location that is sufficiently strong to withstand the maximum pulling capacity of your winch.
- **Always** use factory approved switches, remote controls, accessories and installation components.
- **Always** use grade 5 or better hardware, never weld bolts and never use longer bolts than those supplied from factory.
- **Always** complete winch mounting and attachment of hook-to-hook loop before wiring winch during installation.
- **Always** position fairlead with WARNING label on top.
- **Always** spool the wire rope onto the drum as indicated by the drum rotation label on the winch. Required for automatic brake to work (if winch is so equipped) and for correct installation orientation.
- **Always** prestretch wire rope and respool under load before use. Tightly wound wire rope reduces chances of "binding", which is wire rope working it's way down into a loosely wound wire rope layer, and catching or damaging itself.

CAUTION

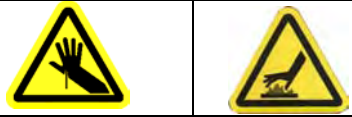

CUT AND BURN HAZARD

Failure to observe these instructions could lead to minor to moderate injury.

To avoid injury to hands and fingers:

- **Always** wear heavy leather gloves when handling a wire rope.
- **Never** let wire rope slip through your hands.
- **Always** be aware of possible hot surface at winch motor, drum or wire rope during or after winch use.

CAUTION

MOVING PARTS ENTANGLEMENT HAZARD

Failure to observe these instructions could lead to minor to moderate injury.

Winching Safety:

- **Always** inspect winch installation and wire rope Condition before operating winch. Frayed, kinked or damaged wire rope must be replaced immediately. Loose or damaged winch installation must be corrected immediately.
- **Never** leave remote control plugged into winch while free spooling, rigging, or sitting idle.
- **Never** hook wire rope back onto itself. This damages the wire rope. Always use a choker chain, wire choker rope or tree trunk protector on the anchor.
- **Always** prior to winching, remove any element that may interfere with safe winch operation.
- **Always** take your time when rigging for a winch pull.
- **Always** be certain the anchor you select will withstand the load, and the strap or chain will not slip.
- **Never** engage or disengage clutch if winch is under load, wire rope is in tension or wire rope drum is moving
- **Always** unspool as much wire rope as possible when rigging. Double line or pick distant anchor point.
- **Never** winch with less than 5 wraps of wire rope around the drum, the wire rope could come loose from the drum.
- **Always** stand clear of wire rope and load during operation.
- **Never** touch wire rope or hook while in tension or under load.
- **Never** touch wire rope or hook while someone else is at the control switch or during winching operation.
- **Never** touch wire rope or hook while remote control is plugged into winch.
- **Always** stand clear of wire rope and load and keep others away while winching.

Always require operator and bystanders to be aware of stability during winching of vehicle and/or load.

- **Always** keep remote control lead clear of the drum, wire rope and rigging. Inspect for cracks, pinches, frayed wires or loose connections. Replace if damaged.
- **Always** pass remote control through a window to avoid pinching lead in door, when using remote inside a vehicle.

NOTICE

AVOID WINCH AND EQUIPMENT DAMAGE

- **Always** avoid continuous side pulls, which can pile up wire rope at one end of the drum. This can damage your wire rope or winch.
- **Always** ensure the clutch is fully engaged or Disengaged.
- **Never** use winch to tow other vehicles. Shock loads can momentarily exceed capacity of wire rope & winch
- **Always** use care to not damage your frame when anchoring your vehicle during a winching operation.
- **Never** "jog" wire rope under load. Shock loads can momentarily exceed capacity of wire rope and winch.
- **Never** use winch to secure a load during transport.
- **Never** submerge winch in water.
- **Always** store the remote control in a protected, clean, dry area.



Specifications for the DC3000LF

ENGINEERING DATA

Rated maximum working load, first layer	3000 lb.	1363 kg
Maximum recommended wire rope diameter	5/16 in	8 mm
Drum dimensions:	Barrel diameter:	5.31 in / 135 mm
	Flange diameter:	8.90 in / 226 mm
	Between flanges:	5.94 in / 151 mm
Total gear reduction	261:1	
Approximate shipping weight	83 lb.	38 kg

MULTI-LAYER PERFORMANCE

Layer	Line Load		Line Speed				Rope Capacity Ø5/16 in. (8mm)	
			12 volt motor		24 volt motor			
	lb	kg	ft/min	m/min	ft/min	m/min	ft	m
1	3000	1363	11	3.4	15	4.5	25	7.6
2	2700	1227	13	3.8	16	5.0	54	16.5
3	2455	1116	14	4.2	18	5.5	85	25.9
4	2250	1023	15	4.6	20	6.0	119	36.3

FIRST LAYER PERFORMANCE

Line Load		Line Speed/Current Draw						Duty Cycle	
		12 volt motor			24 volt motor			12 V	24V
lb	kg	ft/min	m/min	amps	ft/min	m/min	amps	min/10 min	
0	0	28	8.5	95	35	10.7	50	3.1	3.6
1000	454	17	5.2	165	22	6.7	90	2.6	3.1
2000	907	13	4.0	215	17	5.2	115	2.0	2.6
3000	1363	11	3.4	255	15	4.6	145	1.7	2.3

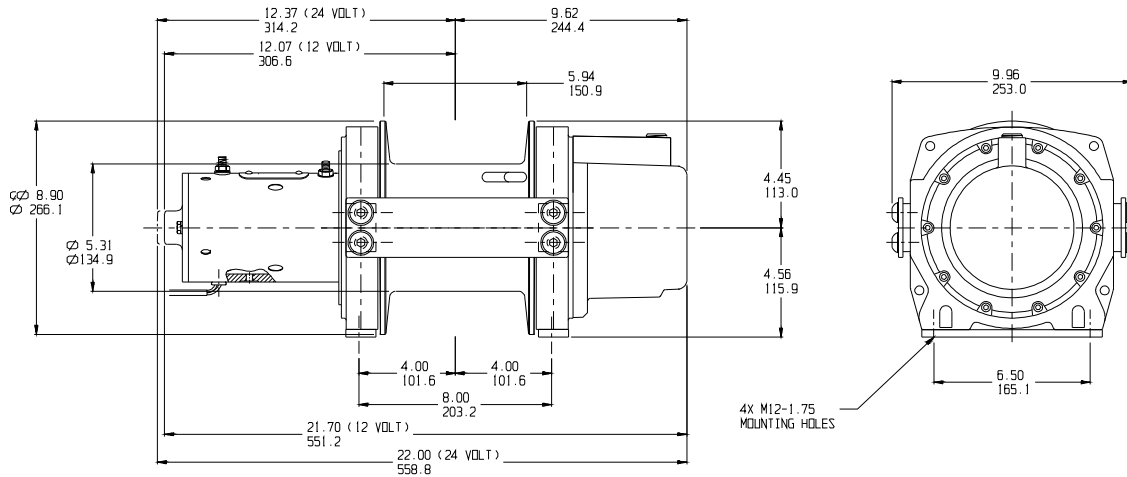

Specifications for the HYD3000LF

ENGINEERING DATA

Rated maximum working load, first layer	3000 lb.	1363 kg
Maximum recommended wire rope diameter	5/16 in	8 mm
Drum dimensions:	Barrel diameter:	5.31 in / 135 mm
	Flange diameter:	8.90 in / 226 mm
	Between flanges:	5.94 in / 151 mm
Total gear reduction	21:1	
Maximum oil flow to winch motor	15 GPM	57 l/min
Approximate shipping weight	68 lb.	31 kg

MULTI-LAYER PERFORMANCE

Layer	Line Load		Line Speed at 5 gpm (19 l/min)		Rope Capacity Ø5/16 in. (8mm)	
	lb	kg	ft/min	m/min	ft	m
1	3000	1363	32	9.8	25	7.6
2	2700	1227	36	10.8	54	16.5
3	2455	1116	39	11.9	85	25.9
4	2250	1023	43	13.0	119	36.3

FIRST LAYER PERFORMANCE

Line Load		Pressure Drop across Motor		Line Speed	
lb	kg	psi	bar	ft/min	m/min
0	0	125	8.6	31	9.5
1000	454	500	34.5	31	9.5
2000	907	850	58.6	31	9.5
3000	1363	1400	96.5	30	9.1

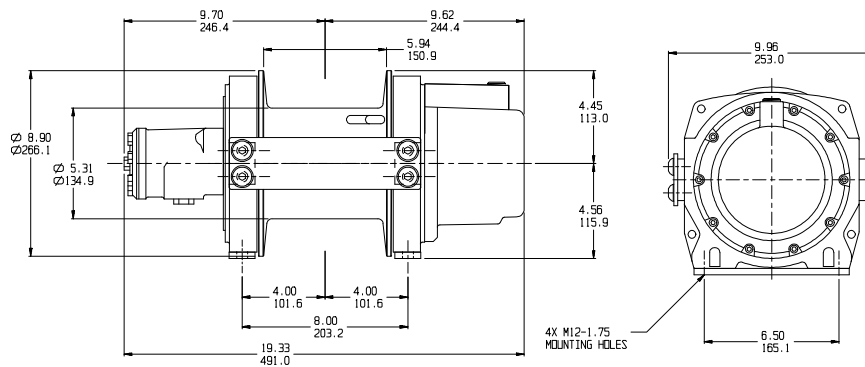
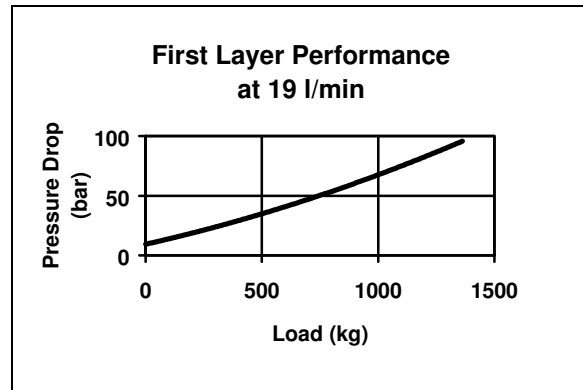
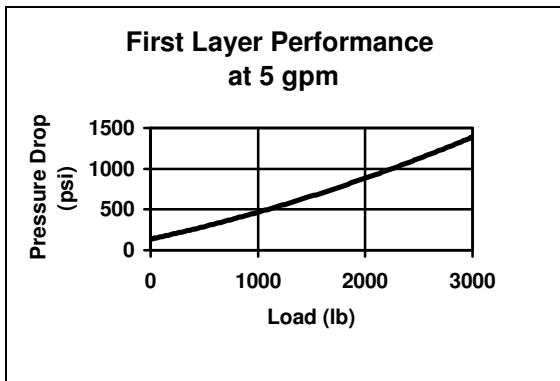

INSTALLATION



WARNING

Any deviation from the illustrated mounting dimensions or instructions could cause the hoist to break under load. This would create an unsafe working condition that could result in serious injury or property damage.

DC3000LF PRE-INSTALLATION CHECKLIST

CHECK TO SEE THAT YOU HAVE RECEIVED THE FOLLOWING:

- **The hoist**
- **The controller**
- **The remote control pendant**
- **The hoist mounting hardware package**

***NOTE:** Upon removing hoist from packaging, check for damage - including bent or cracked tie-plates or housings. Report any damage before installing hoist.*

AND BE SURE THAT:

- **The environment surrounding hoist and controller is free of :**
 - *Combustible vapors*
 - *Chemical fumes*
 - *Oil vapors*
 - *Corrosive material*
- **That air temperatures surrounding hoist and controller do not:**
 - *Exceed 120 °F (40 °C)*
 - *Drop below -20 °F (-29 °C)*
- **That the structure you intend to mount the hoist to is capable of withstanding a minimum line pull of 6000 lbs (2726 kg).**
- **That the support structure you intend to mount the hoist to will not deform under loads of up to 3000 lbs (1363 kg).**
- **That the mounting surface is flat within +/-0.020 in. (0.50 mm)**



INSTALLING THE HOIST

1. Torque all mounting bolts to 35-40 lb-ft.
2. Use supplied fasteners or class 8.8 or better fasteners.

NOTE: The required mounting bolts are M12-1.75 thread. Bolts that are too long may damage drum supports, while bolts that are too short will not have adequate strength. When using the mounting bolts supplied with the hoist, use only 1/4 inch (6.4 mm) to 5/16 inch (8 mm) thick mounting plates. If the mounting plate is thicker than 5/16 inch (8 mm), choose mounting bolts that extend between 15/16 inch (24 mm) and 1-3/8 inch (35 mm) into the drum support. Flat washers should be used between the bolt heads and mounting surface. All tie plates must be in place.

3. Use the following mounting dimensions:

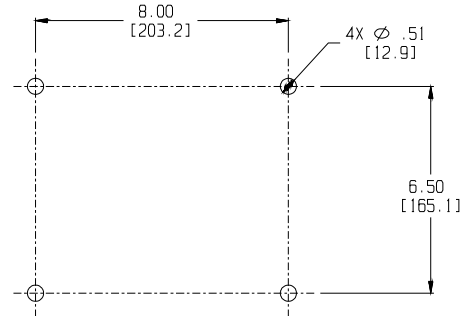

DC3000LF - INSTALLING THE CONTROLLER



WARNING

FIRE HAZARD

The controller can be mounted in a location exposed to the weather; however, it should be protected from the possibility of damage from tools or heavy objects. Special care must be taken to avoid damage to terminals located on top surface of the enclosure. Do not mount controller in an area where it may be used as a step or where tools will be hung or placed on it. Keep tools and other electrically conductive equipment away from terminal at all times. Failure to do so could result in fire.

1. Remove three screws holding cover to controller bracket.
2. Mount controller in an orientation that allows water to drain out from the cover.
3. Mount controller in a location free of excessive vibration.

Note: *be sure to use lock washers to prevent mounting nuts from loosening.*

4. Mount controller so it's protected from damage by tools or heavy objects.
5. Use the following mounting dimensions:

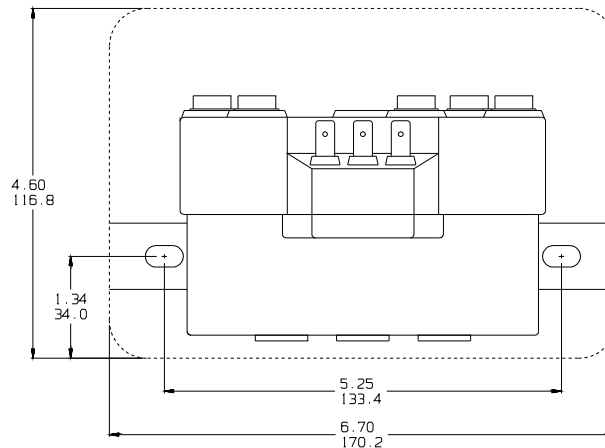

WARNING

CHEMICAL AND FIRE HAZARD

Failure to observe these instructions could lead to severe injury or death.

- **Never** route electrical cables:
 - Across any sharp edges.
 - Through or near moving parts.
 - Near parts that become hot.



DC3000LF - CONNECTING THE HOIST & CONTROLLER

- Use #2 gauge battery cable for all power connections: *Excess cable length can result in a voltage drop causing poor hoist operation.*
- Minimize cable length where possible: *If cables longer than 10 feet (3m) are required, then #0 cable is recommended.*
- Slide electrical terminal boots onto cables before connecting cables to terminals.
- Connect the motor thermal switch wires with splice connectors as shown in the diagram below.
- * Connect the F1, F2, A (for clockwise models only) and ground cables from controller terminals to hoist motor terminals as shown below. For counterclockwise models, the F1 terminal from the controller must be connected to the F2 terminal on the hoist motor and the F2 controller terminal connects to the F1 terminal of the motor.

Note: Make sure all electrical connections are clean and tight.

- Connect positive (+) and negative (-) cables from controller terminals to battery.

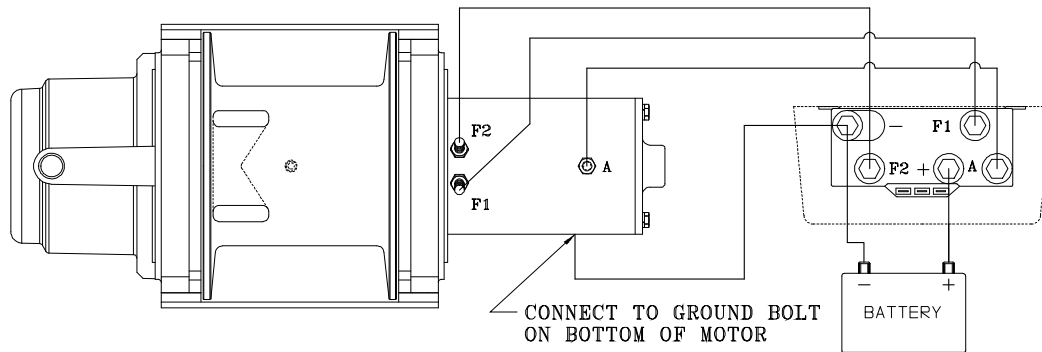

* SHOWN FOR CLOCKWISE MODELS ONLY: READ NOTE ABOVE FOR CCW CONNECTION

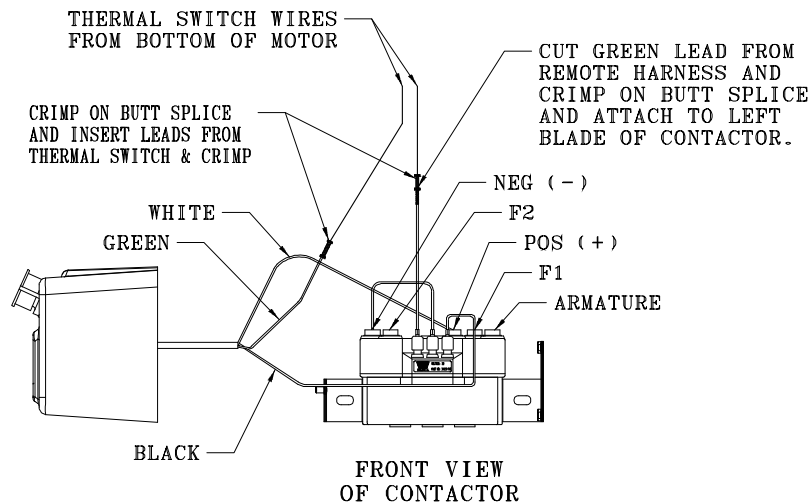

- It is recommended that a power-cut off switch be installed in an easily accessible location. This will provide power shut-off during servicing and act as an added safety feature (use a 300 amp switch)
- It is recommended that a 300 amp circuit breaker be installed in the positive (+) cable near the battery to protect against short circuits.



THE HYDRAULIC SYSTEM

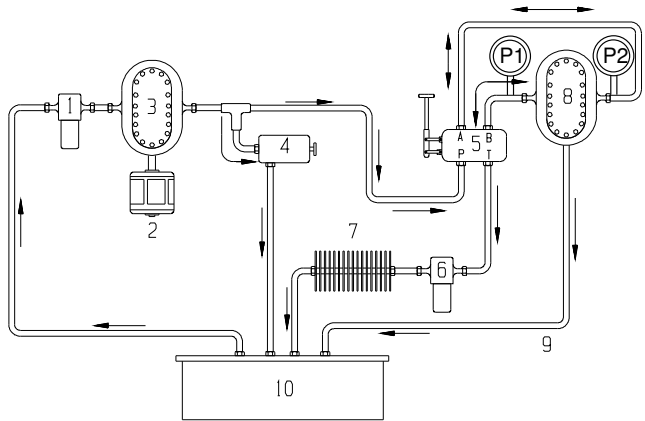

⚠ CAUTION

- Do not exceed the maximum recommended hydraulic pressure or flow of any of the components used.
- The winch control valve must be a tandem center type valve (A & B work ports blocked) to insure proper brake operation. Failure to use proper control valve could cause brake failure resulting in serious injury or property damage.
- The winch works correctly only when hydraulic system components are correct.

NOTE: The pictorial diagram and the following descriptions are intended only as a general guide for reference use. For specific recommendations on component selection, inter-connection, layout, and use, consult a knowledgeable hydraulics representative.

HYDRAULIC FLUID

The hydraulic fluid used with the hoist must be an extreme pressure, anti-wear hydraulic oil with oxidation and corrosion inhibitors. It must contain a foam suppressant, and have a viscosity rating of 100-300 SSU at 15-45 °C.

1. **STRAINER:** This removes larger particles from the hydraulic fluid.
2. **MOTOR:** This is the power source for the hydraulic system. It must be adequately rated to supply the required power. It can be a power take-off (PTO), belt drive from a gasoline or diesel engine, a large electric motor, etc.
3. **HYDRAULIC PUMP:** This converts the mechanical power of the motor into hydraulic fluid power. It must be adequately rated to supply the system with enough power for proper performance. (See *HYD3000 Hydraulic Engineering Data*).
4. **PRESSURE RELIEF VALVE:** This is to limit the system pressure to a safe level (one which will not exceed the maximum pressure rating of any of the components used).
5. **THREE POSITION VALVE:** This is a three-position tandem valve with a center-off position. In the center-off position, the pressure tank ports (labeled "P" and "T") are inter-connected, and the output ports (labeled "A" and "B") are blocked off. The blocked off ports will immediately stop the hydraulic motor rotation. This valve type is required for proper brake operation. This valve is used to control the three basic hoist functions of "Power In", Stop, and "Power out". It may be actuated either manually or electrically. Ensure that the valve is sufficiently rated for pressure and flow rate. **Do not use a standard motor spool valve.**

⚠ CAUTION

Do not use a standard motor valve.

6. **FILTER:** This removes the smaller particles and insoluble contaminants from the hydraulic fluid. Ensure that it is rated for an adequate flow rate. The recommended filtration level is 10 microns nominal or finer.



7. **HEAT EXCHANGER:** This is a device to remove excess heat from the hydraulic fluid. This is an optional device that will be required only if excess heat buildup is a problem due to a small reservoir size, restricted hydraulic fluid flow, extended operating periods, etc.
8. **HYDRAULIC MOTOR:** This supplies power to the hoist. The recommended operating temperature range is 100°F to 150°F (38°C to 66°C). The maximum operating temperature range is -6°F to 180°F (-21°C to 82°C). **DO NOT EXCEED THE FLOW RATING OF THE HYDRAULIC MOTOR.** (See *HYD3000 Hydraulic Engineering Data*).
9. **MOTOR CASE DRAIN LINE:** A motor case drain line will not be required in most cases. Warn's industrial motors supplied with the hoist have internal check valves, and do not require a case drain line unless the motor outlet port (the port connected through the three-position valve back to the reservoir) pressure exceeds 700 psi (50 bar). This will alternately be either port "A" or "B" at the three-position valve depending on the positioning of the valve at either "power in" or "power out". Check outlet port pressure in both positions.
10. **RESERVOIR:** The reservoir is the container for storing the hydraulic fluid. Its functions include storing all the required fluid, helping to moderate fluid temperature, solid contaminant, possibly heating fluid for viscosity control in cold weather, and reducing sloshing with baffles.

The pressure rating of the hoist motor is determined by (a) the maximum allowable pressure at the motor inlet port and (b) the maximum allowable pressure drop across the motor. Pressure drop is defined as the difference between the inlet pressure (P1) and the outlet pressure (P2) at the hoist motor. Exceeding the maximum inlet pressure may damage the motor. Exceeding the maximum pressure drop may cause failure of hoist components. **Maximum allowable values are:**

Maximum pressure at motor inlet	1900 psi (131 bar)
Maximum pressure drop for rated load	1900 psi (131 bar)
Maximum continuous system flow rate	15 gpm (57 l/min)
Maximum system back pressure (w/o case drain line)	700 psi (48 bar)



OPERATING INSTRUCTIONS



WARNING

This hoist can present hazards from the cable, drum pinch points, falling loads, and ropes or rigging under tension. Failure to observe the warnings below could result in personal injury, property damage or loss of life.

SAFE OPERATING PROCEDURES

NEVER:

- **Place any part of your body or clothing near rotating or moving parts:** *Rotating drum with rope under tension can create a pinch point.*
- **Handle ropes or operate hoist without wearing eye protection and heavy gloves**
- **Lift, pull, or otherwise transport people with hoist**
- **Lift, pull, support or otherwise transport loads over people**
- **Attempt to lift loads greater than rated capacity of the hoist:** *(3000 lbs/1363 kg, single line) Excessive loads may cause hoist, rope or structural failure resulting in a dropped load. Excess loads can create undetectable damage, which may cause unit to fail even when lifting loads within its rated capacity. Note: If the load is greater than hoist's rated capacity - use a snatch block with double or multiple line rigging. Any rigging must be adequately rated.*
- **Allow two-blocking to occur:** *Two-blocking can cause the load to exceed the rated load of the hoist. Two blocking is defined as the condition in which the lower load block or hook assembly comes in contact with the upper load block or boom point sheave assembly.*
- **Allow hydraulic system, electric motor or load brake to overheat**
- **Handle rope or rigging while anyone is at controls or while operating hoist**
- **Put rope around an object and hook it back to rope:** *This will damage the rope.*
- **Use hoist with less than five (5) wraps of rope around hoist drum:** *The cable anchor is not designed to hold rated load. The rope may pull free and drop the load with fewer than five wraps of rope on the hoist drum.*
- **Let rope slip through your hands**

ALWAYS:

- **Make sure the rope spools in the right direction:** *Hoists are equipped with an automatic brake and will not function if the rope spools off the drum in the wrong direction. Note: The rope spooling direction will accidentally be reversed if rope is run all the way out and re-spooled in with control switch in power out" direction.*
- **Inspect and carefully rewind rope after each use:** *Cut, kinked, or frayed areas severely reduce original tensile strength of rope. Replace rope if damaged.*
- **Inspect hydraulic system or electrical connections before using hoist.**
- **Stand clear of the rope and load during hoist operation **WARNING!**** *You, as the owner or operator of Warn Industries equipment, have the following responsibility: To train users on the operation of this hoist; to warn them of any potential dangers and hazards; and to ensure that the controller and hoist assembly are installed, operated, adjusted, and serviced only by qualified personnel familiar with its construction and operation.*



CHECKING THE INSTALLATION

- Recheck mounting hardware for loose bolts, etc.
- Be sure all hydraulic system components and connections are correct
- Be sure all connections are tight and secure
- **Check motor rotation:** Hoist should power in and rotate the direction indicated by the drum rotation label on top of the drum support. If hoist rotates in opposite direction, recheck hydraulic or electrical schematic and connections.

INSTALLING THE WIRE ROPE

1. Insert rope through slot in drum as shown below
2. Form a loop and reinsert end into slot: "Live" or load carrying portion of rope must be against drum flange.
3. Insert a 7/16 inch hex nut into loop and pull live end of rope to seat hex nut into slot: End of rope must remain visible in slot as shown. The hex nut acts as a wedge to lock the rope into the slot.
4. With end of rope securely installed, carefully wind length of rope evenly onto drum: Keep rope under tension at all times.
5. Always maintain a minimum of five (5) wraps of rope on drum: Fewer wraps may cause the end of the rope to pull free of the drum and drop the load.

CAUTION

Rope must spool onto drum according to drum rotation label on hoist, or brake will not function. Use only rope specified under "performance features." Rope must be installed as shown in illustration below.

PULL 7/16 HEX NUT AND LIVE PORTION OF ROPE
THRU SLOT TO SEAT THE HEX NUT INTO DRUM

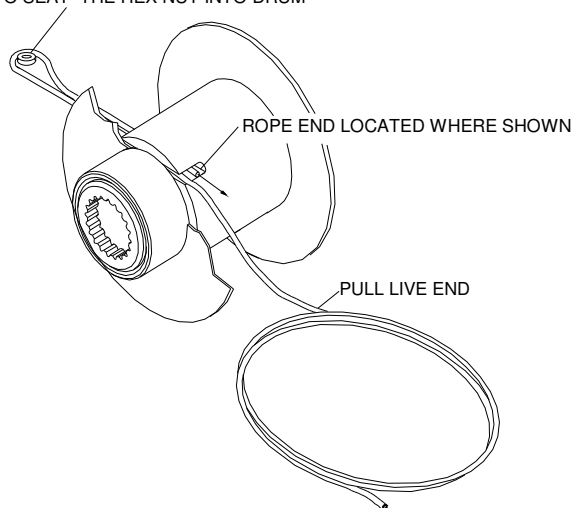

MAINTENANCE & REPAIR

PERIODIC PREVENTATIVE MAINTENANCE

- **Check all mounting bolts and make sure they are tightened to proper torque:** *Replace any damaged fasteners.*
- **Periodically check all connections to be sure they are tight and free of corrosion**
- **Check rope for visible damage every time hoist is operated:** *Examples of damage are: cuts, knots, mashed or frayed portions, and broken strands. Replace rope immediately if damaged. Failure to replace a damaged rope could result in breakage.*
- **Regularly check brake for slippage or drift:** *This is detected visually when hoist is under load. If hoist drum continues to turn after controls are released, brake may need to be replaced.*
- **Keep outside of hoist free of dirt, oil, grease, water and other substances:** *When necessary, clean off built up dirt. Wipe any overflow grease from bearings.*

PREVENTATIVE MAINTENANCE SCHEDULE

MAINTENANCE CHECK OR ACTIVITY	AFTER FIRST OPERATION	BEFORE EACH USE	SEMI-ANNUALLY OR AFTER EACH 25 HOURS OF OPERATION
CHECK FASTENERS	X		X
CHECK HYDRAULIC CONNECTIONS	X		X
SPOOL OUT AND CHECK ROPE		X	
VISUAL CHECK OF HOIST AND CONTROL	X	X	X

CUSTOMER SUPPORT

Should you have any questions about this product or these instructions, please call WARN's customer service through the numbers below, Monday thru Friday between 7:00 AM and 4:00 PM Pacific Time for assistance.

UNITED STATES	INTERNATIONAL
PHONE: 503.722.1200 or (800) 543-9276 (US only)	PHONE: 503.722.3008
FAX: 503.722.3000	FAX: 503.722.3005

Or for e-mail support, visit our web site www.WARN.com and click on customer service section.



TROUBLE SHOOTING

DC3000LF:



WARNING

Personal Injury

Failure to observe these instructions could lead to severe injury or death.

Never lean over battery while making connections
Always disconnect all wires from battery, before beginning work.
Always disconnect negative terminal first and reconnect negative terminal last.
Always remove jewelry and wear eye protection.

PROBLEM	POSSIBLE CAUSE	CORRECTIVE ACTION
If hoist won't operate in either direction -or- Motor doesn't operate	<i>Power is not connected</i> -or- <i>Emergency on/off switch (optional) is in "off" position</i>	A) Check wiring connections. Check for 12 volt at positive (+) terminal on controller. Check for voltage at F1, F2 and A terminals with remote switch in either direction. B) Check position of emergency on/off switch.
	<i>Power to remote pendant has been interrupted</i>	<i>Check for 12 volts at center pin of remote socket on controller. Check continuity of remote lead connector from center pin to either side pin with remote control pendant on/off switch in both positions. Replace remote control pendant if there is no continuity.</i>
If hoist will power-out but not power-in	<i>Failure in remote control pendant switch or wiring</i>	<i>Check for 12 volts at center pin of remote socket on controller. Check continuity of remote lead connector from center pin to either side pin with remote control pendant on/off switch in both positions. Replace remote control pendant if there is no continuity.</i>
	<i>Failure of components or wiring inside controller</i>	<i>Check for 12 volts at center pin of remote socket on controller. Check continuity of remote lead connector from center pin to either side pin with remote control pendant on/off switch in both positions. Replace remote control pendant if there is no continuity. If none of these corrective actions resolves problem, return controller to Warn Industrial for service.</i>
If hoist will power-in but not power-out	<i>Power to remote control pendant has been interrupted</i>	<i>Check for 12 volts at center pin of remote socket on controller. Check continuity of remote lead connector from center pin to either side pin with</i>



		<i>remote control pendant on/off switch in both positions. Replace remote control pendant if there is no continuity</i>
If motor tries to power-out but hoist stalls or locks-up	<i>Load brake failure</i>	<i>Service or replace load brake.</i>

PROBLEM	POSSIBLE CAUSE	CORRECTIVE ACTION
If hoist operates in both directions but will not lift rated load	<i>Low voltage at hoist</i>	<p>A) <i>Be sure wiring cable size guidelines have been met.</i></p> <p>B) <i>Check condition of battery.</i></p> <p>C) <i>Check all power wiring and connections for corrosion. Clean and tighten connections.</i></p>
If hoist slows down and stalls during power-out	<i>Brake needs service</i>	<i>Service or replace load brake.</i>
If hoist vibrates badly or is noisy during lifting or lowering of load	<i>Brake needs servicing</i>	<i>Service or replace load brake.</i>
	<i>Mounting surface is not flat or tie plate is bent</i>	<i>Check to make sure mounting surface is flat to within +/- 0.020 in. (0.50 mm). Replace tie plates if necessary. Check for bent or cracked housings.</i>



HYD3000LF:

 WARNING
Personal Injury
Failure to observe these instructions could lead to severe injury or death.
<p>Never use a relief valve, which exceeds the hydraulic motor pressure rating. Use of this valve overloads the winch</p>

NOTE: Most hydraulic system failures follow the same pattern: a gradual or sudden loss of pressure or flow with a resulting loss of motor power. Any one of the system’s components may be at fault. Refer to Operator’s Manual for specific recommendations and specifications for your hydraulic system. For specific recommendations, consult a knowledgeable hydraulics representative.

General hydraulic pressure recommendations are shown below:

Hoist Model	Motor Type	Maximum Pressure at the Motor Inlet (P1)	Maximum Pressure drop across the Motor (P1-P2)
3000LF	3.0 cu. in. (50 cc)	1900 psi (131 bar)	1900 psi (131 bar)

PROBLEM	POSSIBLE CAUSE	CORRECTIVE ACTION
If hoist won’t operate in either direction	<i>No hydraulic pressure</i>	<i>Check hydraulic system schematic and connections</i>
	<i>Geartrain, brake, or motor failure</i>	<i>Send hoist to authorized Warn Industrial service center for repair</i>
If hoist will power-out but not power-in	<i>Brake assembled incorrectly</i>	<i>Repair or replace brake assembly</i>
If hoist will power-in but not power-out or stalls during power-out	<i>Load brake failure</i>	<i>Service or repair load brake</i>
If hoist operates in both directions but will not lift rated load	<i>Low system pressure or excessive system back pressure</i>	<i>Check system pressure at motor inlet and outlet ports</i>
If hoist vibrates badly or is noisy during lifting or lowering of load	<i>Brake needs servicing.</i>	<i>Service or replace load brake.</i>
	<i>Mounting surface is not flat or tie rod is bent.</i>	<i>Check to make sure mounting surface is flat to within +/- 0.020 in. (0.50 mm). Replace tie plates if necessary. Check for bent or cracked housings.</i>



REPLACEMENT PARTS

REPLACEMENT PARTS DC3000LF

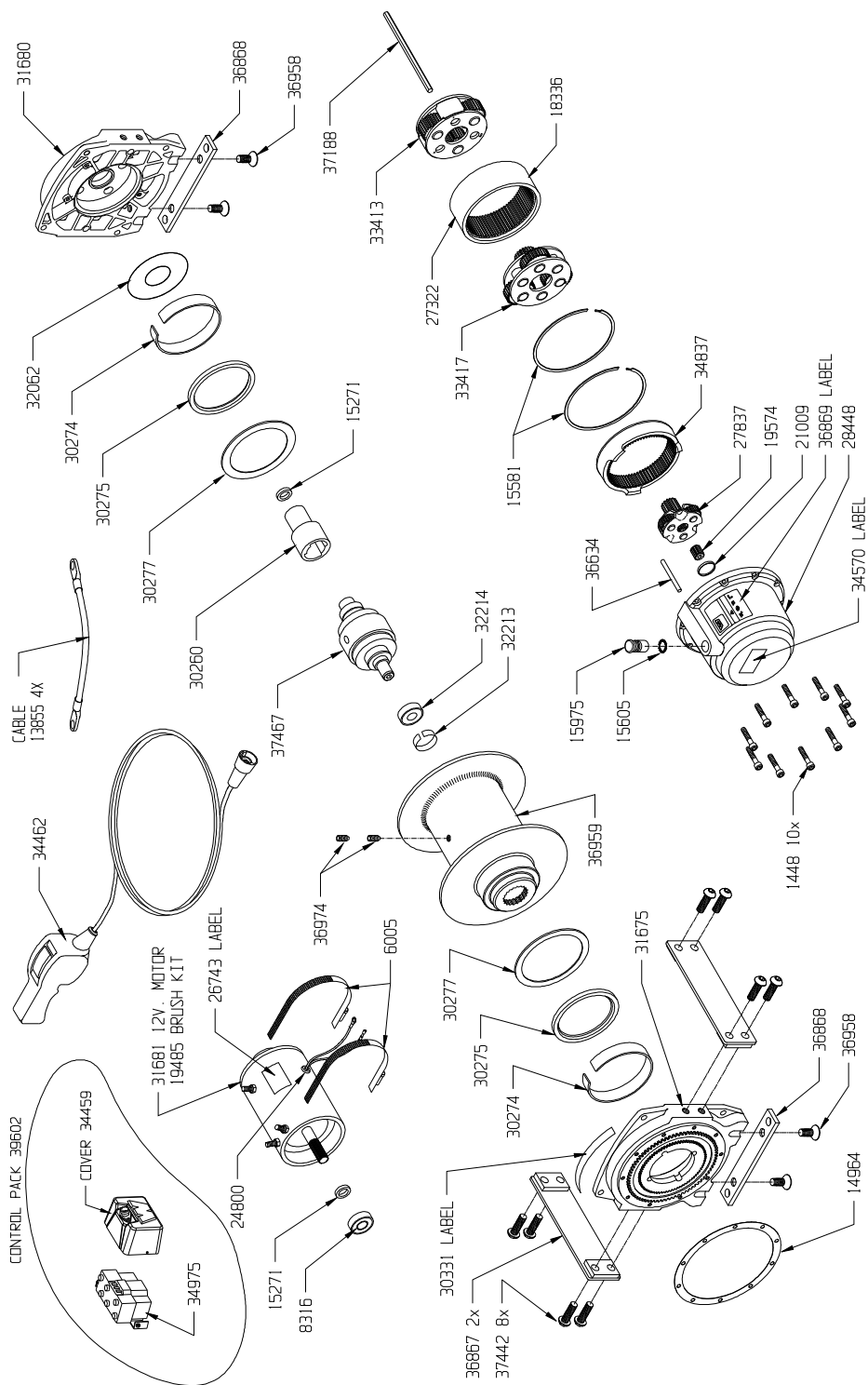

REPLACEMENT PARTS HYD3000LF

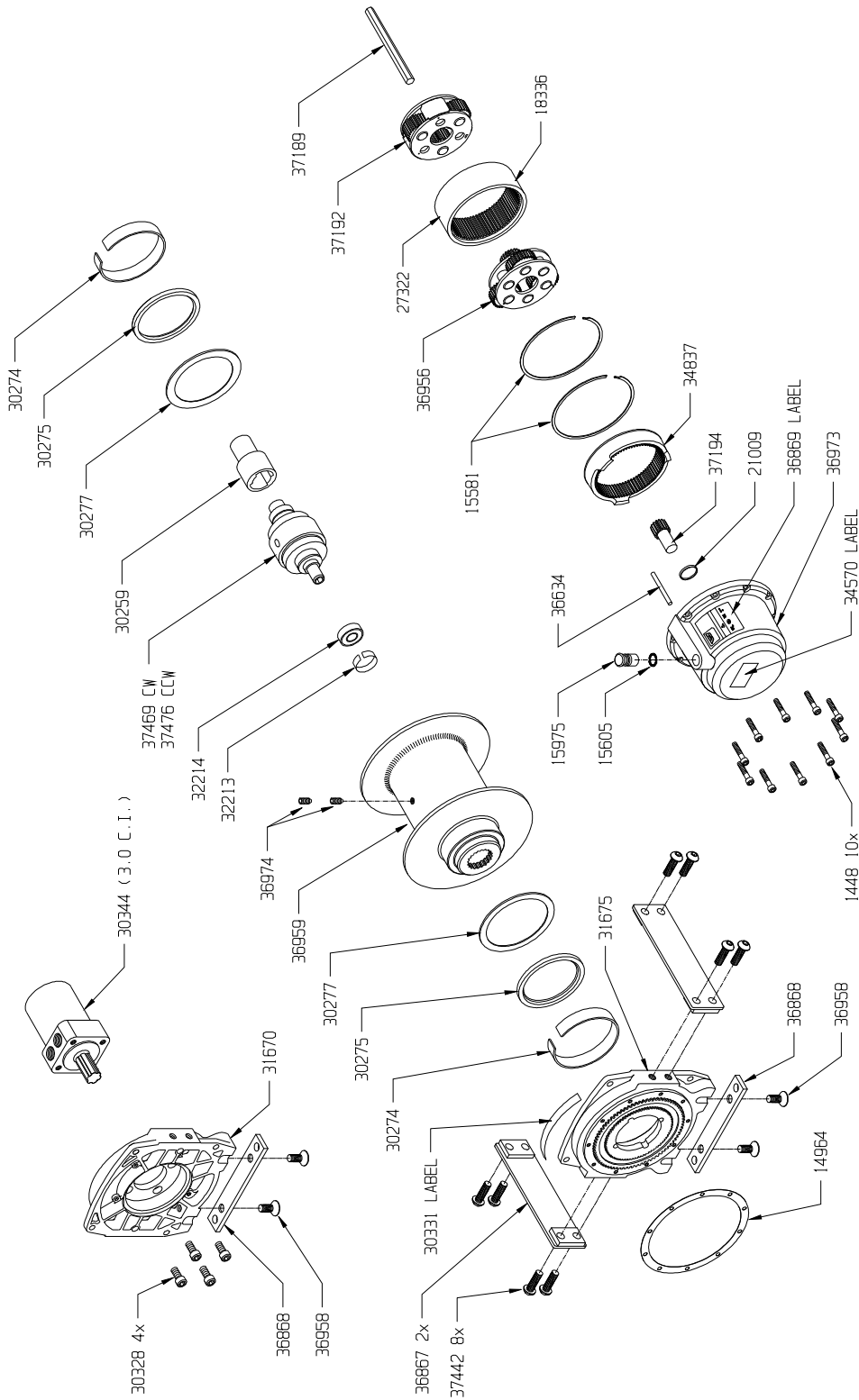



WARN[®] COMMERCIAL PRODUCTS

LIMITED ONE (1) YEAR WARRANTY STATEMENT

Warn Industries, Inc. (WARN) warrants to the original purchaser that the mechanical components and electrical components of the "WARN" Products specified below will be free of defects in material and workmanship for a period of one (1) year from the original date of purchase. This Warranty applies only to the original purchaser of the Products. To obtain any warranty service, you must provide WARN with proof of purchase and date of purchase acceptable to WARN, such as a copy of your purchase receipt. This warranty does not cover the removal or reinstallation of the Product. WARN will, at its option, repair, replace or refund the purchase price of a defective Product or component, provided you return the defective Product or component during the warranty period, transportation charges prepaid, to Warn Industries Service Department or a Factory Authorized Service Center. Attach your name, address, telephone number, a description of the problem, and a copy of your receipt and original bill of sale bearing the WARN serial number of the defective Product and date of purchase.

This warranty does not apply (i) to parts or components excluded below, or (ii) if the Product has been damaged by accident, abuse, misuse, collision, overloading, modification, misapplication, improper installation, or improper service. This warranty is void if any WARN serial number has been removed or defaced.

THE WARRANTY SET FORTH ABOVE IS THE ONLY WARRANTY. THERE ARE NO OTHER WARRANTIES, EXPRESS OR IMPLIED, INCLUDING BUT NOT LIMITED TO IMPLIED WARRANTIES OF MERCHANTABILITY OR FITNESS FOR A PARTICULAR PURPOSE.

ANY IMPLIED WARRANTY WHICH BY LAW MAY NOT BE EXCLUDED IS LIMITED IN DURATION TO ONE (1) YEAR FROM THE DATE OF ORIGINAL RETAIL PURCHASE OF THE PRODUCT.

WARN SHALL NOT BE LIABLE FOR SPECIAL, INDIRECT, INCIDENTAL OR CONSEQUENTIAL DAMAGES (INCLUDING, BUT NOT LIMITED TO, LOST PROFITS, DOWN TIME OR LOSS OF USE) UNDER ANY LEGAL THEORY, EVEN IF WARN WAS ADVISED OF THE POSSIBILITY OF SUCH DAMAGES.

Some states do not allow the exclusion of implied warranties or the exclusion or limitation of liability for incidental or consequential damages, or limitations on how long an implied warranty lasts, so the above limitation or exclusion may not apply to you. This warranty gives you specific legal rights. You may also have other rights that vary from state to state.

WARN reserves the right to change Product design without notice. In situations in which WARN has changed a Product design, WARN shall have no obligation to upgrade or otherwise modify previously manufactured Products.

No WARN dealer, agent or employee is authorized to make any modification, extension or addition to this warranty.

Warranty inquires and Products returned for warranty service should be sent to:

WARN INDUSTRIES, INC

Customer Service Department
12900 SE Capps Road
Clackamas, OR 97015

1-800-543-WARN (1-800-543-9276)

Products covered by this Warranty

Commercial Winch Products
Commercial Hoist Products
Commercial Accessory Products

Products Not Covered by this Warranty

Finish and Wire Rope for Commercial Winches
Finish and Wire Rope for Commercial Hoist Products
Finish and Wire Rope

