

INSTALLATION INSTRUCTIONS

Remove the factory automatic hub parts as described in Warn hub installation instructions P/N #28760, #28761. Proceed to remove the clutch assembly.

1. Compress the brake spring (using needle nose pliers) and line up the gap with one of three screws, be sure **not** to remove the shoe from the drum and be careful not to compress the spring excessively.

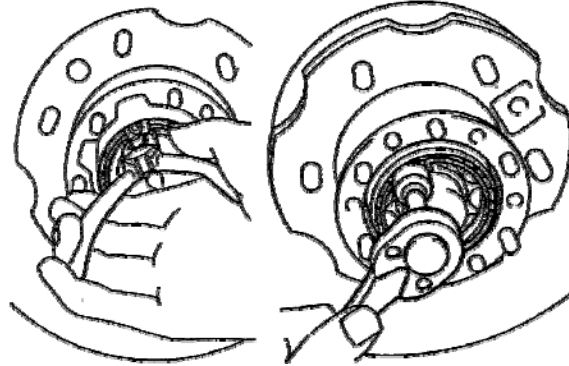

2. To remove the screw use a torx socket. Next align the spring gap with the 2nd screw and remove it. Finally, remove the 3rd screw by the same process and detach the brake. Now the large nut can be removed and discarded.

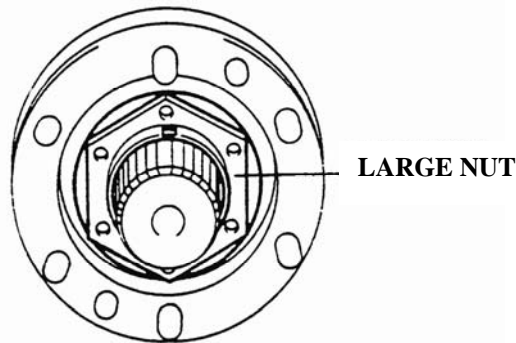

CAUTION: SPINDLE NUTS MUST BE INSTALLED AS DESCRIBED IN THE TOYOTA SERVICE MANUAL USING A LARGE SOCKET AND TORQUE WRENCH. DO NOT USE A PUNCH AND CHISEL TO TIGHTEN.

NORMAL ADJUSTMENT:

3. Slide Claw Washer over spindle until it rests on outer bearing. Install and tighten adjusting nut to 43 ft.lbs.. Loosen adjusting nut 90 degrees or until it can be turned by hand. Re-tighten the adjusting nut to 18 ft. lbs., then install the star washer and lock nut. Tighten the lock nut to 33 ft. lbs.. Make sure the bearing has no play. Secure the lock nut by bending one of the star washer tabs over the adjusting nut and one over the lock nut. Now you are ready to install your Warn locking Hubs.

