



# INSTALLATION INSTRUCTIONS

## For Mounting a Warn Winch on Multi-Mount Kit No. 26370

**NOTE:** This unit is to be used only on vehicles equipped with a Warn Front Receiver or a class 3 receiver trailer hitch.

1. Before bolting down the winch, it is necessary to install the "quick-connect" electrical cable on the winch in place of the long red and black battery cables.
- If the winch is the HS9500i, XD9000i or X8000i, refer to **Figure 1** and remove the solenoid cover by removing the upper screw on each end. Then loosen the two lower screws on one end only. Tilt the cover forward and down and then lift off. Remove the long red cable from the solenoid terminal and install the white (+) lead of the quick-connect. Remove the long black cable from the bottom of the winch motor and install the black (-) lead of the quick-connect. Reinstall the cover. **Proceed directly to step 5.**

**FIGURE 1**

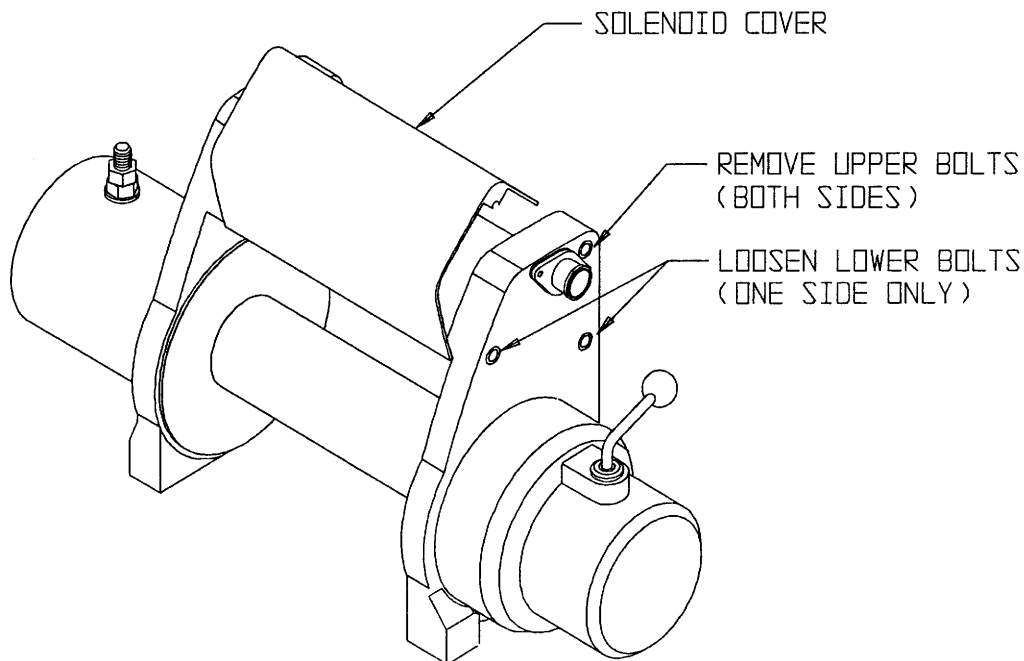

- If the winch has a separate control pack with a black plastic cover similar to **Figure 2**, remove the plastic cover being careful not to strain the internal wiring. Replace the cables as described above. Reinstall the cover and proceed to step 2.
2. Attach the control pack mounting bracket to the bottom of the control pack (**Figure 2.**)

**FIGURE 2**

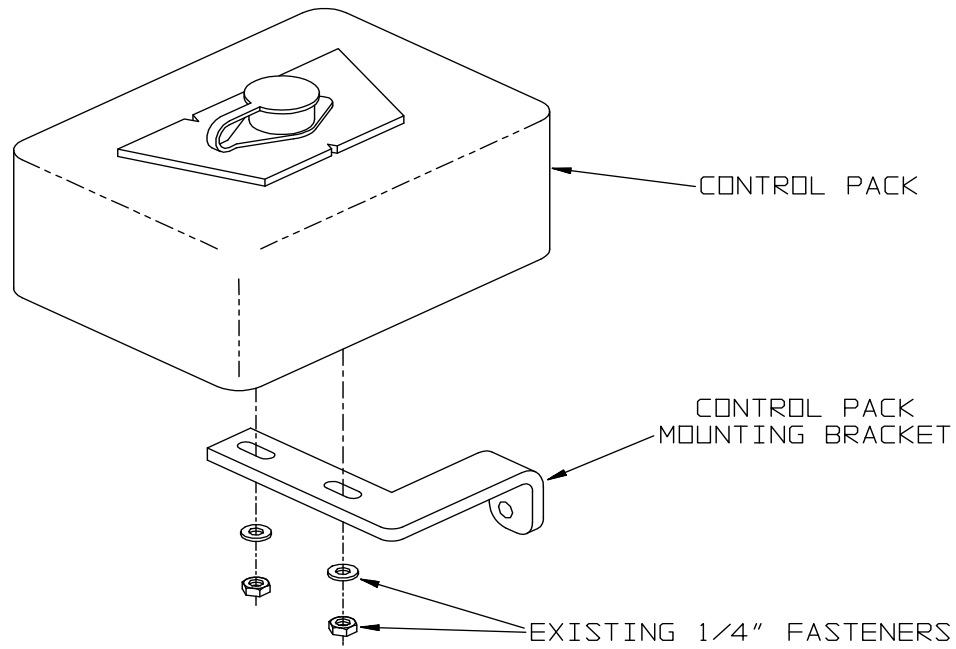

3. Refer to the instructions provided with the winch and complete the electrical connections of the control pack to the winch motor.
4. The control pack assembly is to be mounted over the winch motor (**Figure 3**) with the bracket tab under the tie rod bolt.

**FIGURE 3**

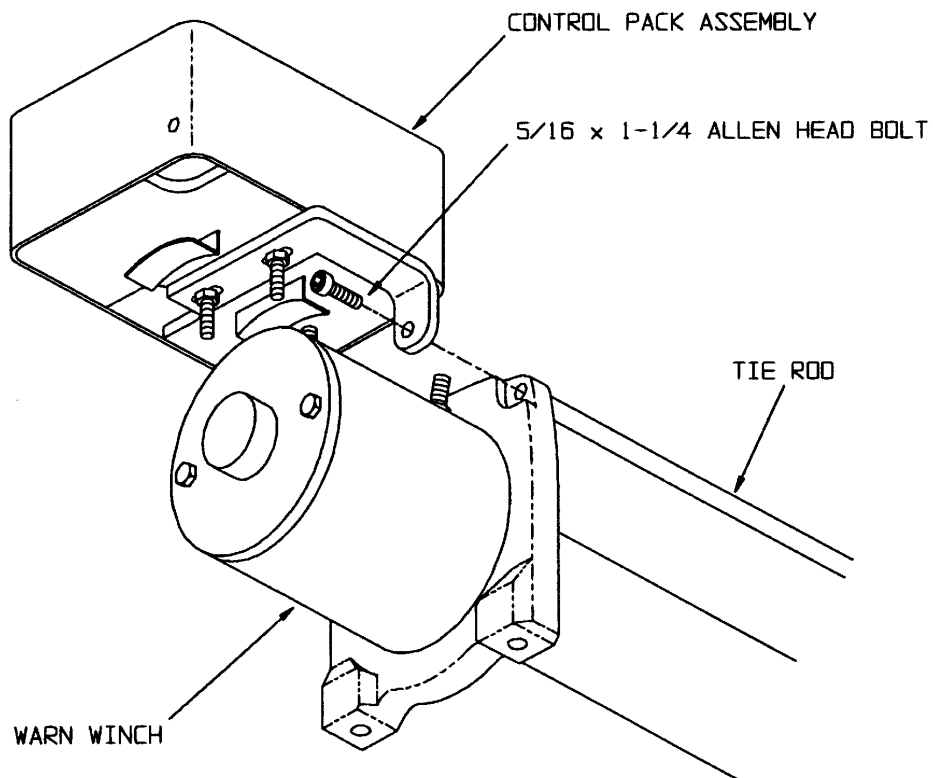

5. Install the fairlead on the front of the winch mounting plate (**Figure 4.**)

**FIGURE 4**

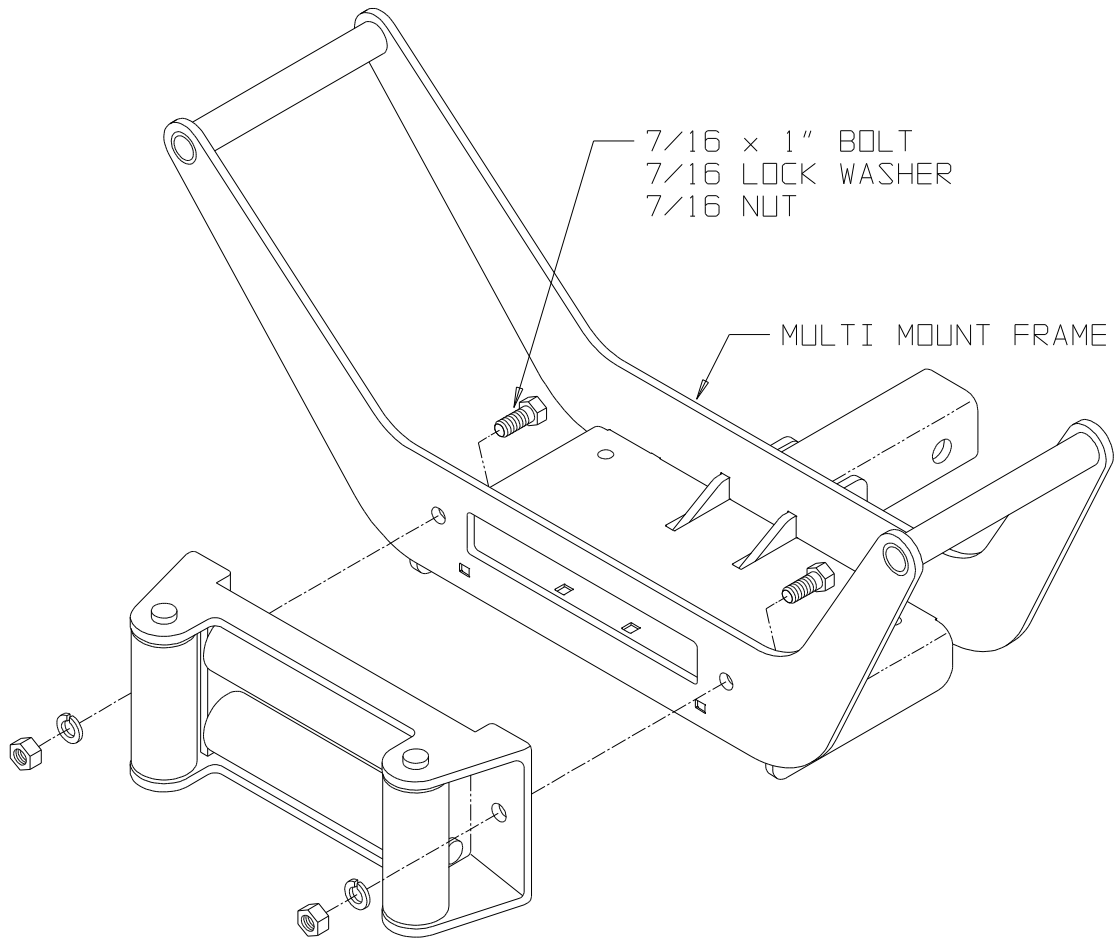

6. Install the winch to the mounting plate using the instructions and fasteners provided with the winch.
7. The 6 foot electrical quick-connect cable furnished is intended for connection to the battery on vehicle front receiver installations. For winch use at the rear of vehicle, longer quick-connect cables are available from Warn dealers. For 20 foot kit, order part number 32963. For 24 foot kit, order part number 32966. Choose a location on the bumper or grille to mount the quick-connect plug as shown in **Figure 5**. Be sure that the plug from the winch will reach when the multi-mount is inserted in the receiver with hitch pin in place. Connect the + and - cable ends to the vehicle battery.

**FIGURE 5**

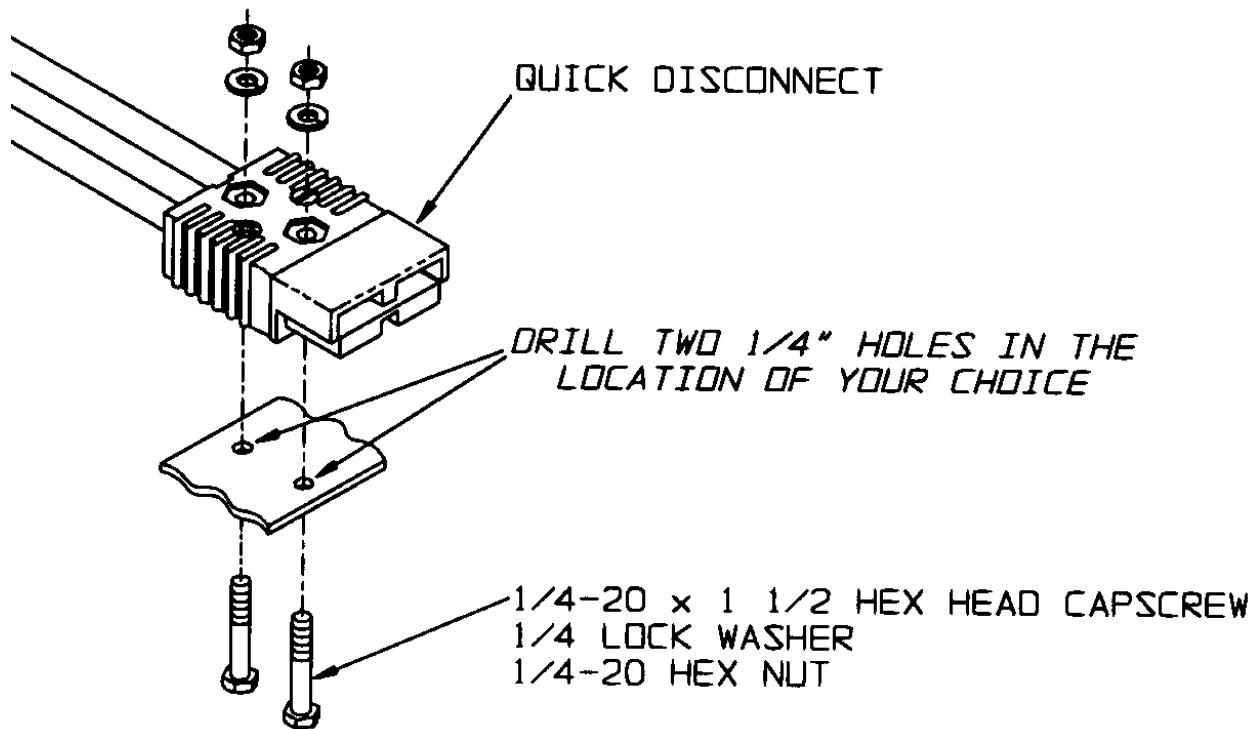

8. Snap the dust cover into the vehicle mounted plug to keep it clean when not in use. The lanyard can be attached to one of the cables or to other locations.

**NOTE:** The quick-connect plug mounted on the vehicle and wired to the battery makes an ideal point to connect booster cables. A heavy duty 16 foot set of boosters made for this purpose is available from Warn dealers under part number 26771.