

Parts List

1	Grille guard
1	Driver / left side frame mounting bracket
1	Passenger / right side frame mounting bracket
1	Driver / left side support bracket, top
1	Passenger / right side support bracket, top
1	LED support flange
2	'Z' bolt plate, M8 - 1.25mm x 25mm
2	Button head bolt, M8 - 1.25mm x 25mm
2	Hex bolt, M8
2	Clip nut, M8
2	Flat washer, M8
6	Flat washer, M8 x 24mm OD x 2mm
6	Lock washer, M8
4	Hex nut, M8
4	Fine thread hex bolt, M12 - 1.25mm x 55mm
6	Hex bolt, M12 - 1.75mm x 35mm
16	Flat washer, M12 x 32mm OD x 3mm
10	Lock washer, M12
6	Hex nut, M12

Tools Required

Wrench

Torque Specifications

METRIC		
M6 bolt		3 ft.-lbs.
M8 bolt		7 ft.-lbs.
M10 bolt		16 ft.-lbs.
M12 bolt		28 ft.-lbs.
SAE		
1/4" bolt		3 ft.-lbs.
5/16" bolt		7 ft.-lbs.
3/8" bolt		16 ft.-lbs.
7/16" bolt		20 ft.-lbs.
1/2" bolt		28 ft.-lbs.

Level of Difficulty

Easy



Scan for helpful install tips

Product Image



Brackets and Hardware

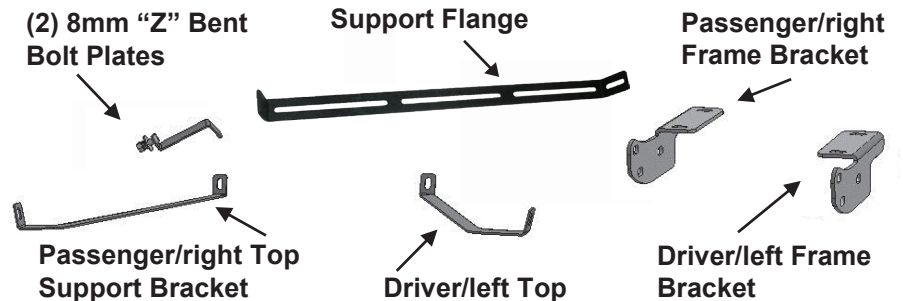

Notes and Maintenance

Before you begin installation, read all instructions thoroughly.

Proper tools will improve the quality of installation and reduce the time required.

Grille guard may interfere with the performance of forward facing cameras and sensors.

For black finishes, mild soap may be used to clean the product.

Refer to the table on the left when securing hardware during the installation process to help prevent damage to the product or vehicle.

PROCEDURE:

1. REMOVE CONTENTS FROM BOX. VERIFY ALL PARTS ARE PRESENT. READ INSTRUCTIONS CAREFULLY. MINOR CUTTING IS REQUIRED. ASSISTANCE IS RECOMMENDED. FOR "XD" GAS AND DIESEL MODELS ONLY, EXCLUDES NON-XD 2017-ON MODELS. INSTALLATION MAY INTERFERE WITH FORWARD FACING FRONT SENSORS.
2. Starting from under the front of the vehicle, remove the factory tow hooks if equipped, (Figures 1 & 2).
NOTE: Tow hooks cannot be reinstalled.
3. Select the passenger/right Frame Mounting Bracket, (Figure 3). Use the included (2) 12-1.25mm x 55mm **SPECIAL Fine Thread** Hex Bolts, (2) 12mm Lock Washers and (2) 12mm Flat Washers to attach the Mounting Bracket to the holes in the bottom of the frame, (Figures 3 & 4). Do not tighten hardware at this time. Repeat to install the driver/left Frame Bracket.
4. Open the hood and remove the plastic cover from the top of the radiator, (Figure 5). Next, remove the clips attaching the top and center of the grille. Leave the bottom of the grille attached at this time.
NOTE: The grille is held in place with several plastic lock clips. Insert a flat blade screwdriver into the slot in the lock clip and rotate approximately 1/4-turn to release lock clips.
5. Select (1) 8mm "Z" Bolt Plate, (Figure 6). Locate the factory hole in the radiator core support, (Figures 7 & 10). Insert the Bolt Plate from the back and out through the front of the core support, (Figure 8). Tilt the grille forward slightly for access. Temporarily hold the Bolt Plate in place with (1) 8mm Flat Washer,
 - a. 8mm Lock Washer and (1) 8mm Hex Nut, (Figure 9). Leave hardware loose at this time. Repeat to install the driver/left Bolt Plate.
6. Push the grille assembly back against the Bolt Plate hardware. Mark the locations where the plastic tabs on the underside/back of the top cover on the grille hit the 8mm hardware, (Figure 9). Temporarily remove the grille assembly and move it to a clean, stable work surface, (Figure 10).
7. Use a sharp knife or hacksaw blade to carefully cut the plastic tabs off of the underside of the cover to clear the hardware, (Figure 9). **IMPORTANT:** The cover must fit tight against the radiator core support. Only remove the plastic material under the cover interfering with the fit of the cover.
8. Reattach the grille assembly at the bottom only, do not reattach the top of the grille at this time.
9. To install an LED light into the light bar cage, select an LED light, mounting hardware and brackets (sold separately). Attach the hardware to the support flange.
10. With the LED light attached to the support flange, place a clip nut on both ends of the support flange. Insert an 8mm hex bolt, lock washer and flat washer into the clip nut. Leave enough space between the flat washer and clip nut to slot the support flange into the light bar cage on the grille guard.
11. Place the grille guard face down on a flat, stable surface. Insert the support flange into the light bar cage on the grille guard and ensure the flat washer, lock washer and head of the hex bolt are on the outside of the center flange.

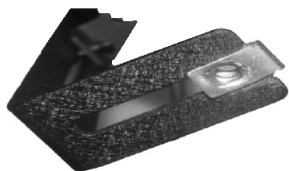
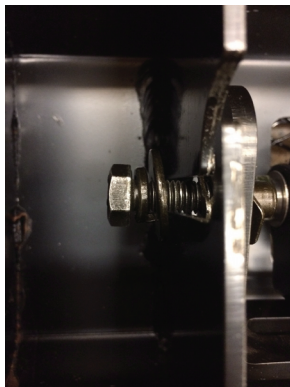

12. With assistance, position the Grille Guard onto the outside of the Frame Mounting Brackets. Attach the Grille Guard to the Brackets with the included (6) 12-1.75mm x 35mm Coarse Thread Hex Bolts, (12) 12mm Flat Washers, (6) 12mm Lock Washers and (6) 12mm Hex Nuts, **(Figures 11 & 12)**. Do not tighten hardware at this time.
13. Select the passenger/right Top Support Bracket, **(Figure 13)**. Insert the Support Bracket through the correct opening in the grille so that the Bracket will properly line up with the factory hole in the radiator core support, (See **Step 6**), and the upright on Grille Guard, **(Figures 14 & 15)**. Reinstall the 8mm Bolt Plate into the factory hole in the passenger side of the radiator core support. Carefully pull the top of the grille forward to access the 8mm Bolt Plate, **(Figure 9)**. Attach the inner end of the Top Support Bracket to the Bolt Plate with (1) 8mm Flat Washer, (1) 8mm Lock Washer and (1) 8mm Hex Nut, **(Figures 14 & 15)**. Attach the outer end of the Top Bracket to the upright with (1) 8mm x 25mm Button Head Bolt, (2) 8mm Flat Washers, (1) 8mm Lock Washer and (1) 8mm Hex Nut, **(Figure 16)**. Do not tighten at this time. Repeat to install the driver/left Top Support Bracket.
14. Level and adjust the Grille Guard and tighten all hardware at this time including all Top Support Bracket hardware.
15. Reattach the grille assembly and the plastic cover on the radiator.
16. Do periodic inspections to the installation to make sure that all hardware is secure and tight.

Passenger/right side installation pictured

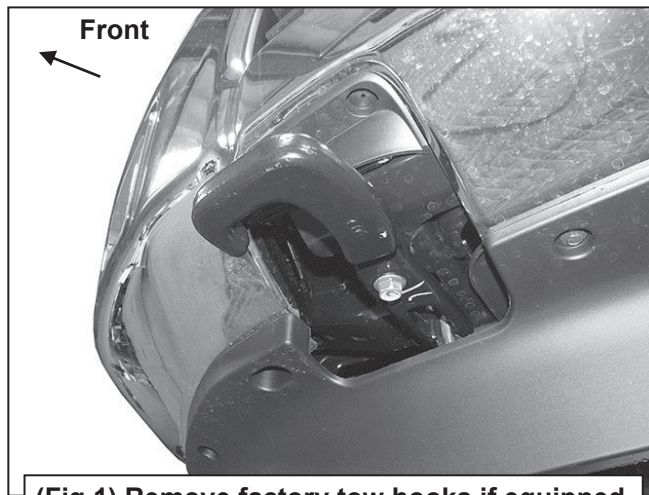

(Fig 1) Remove factory tow hooks if equipped

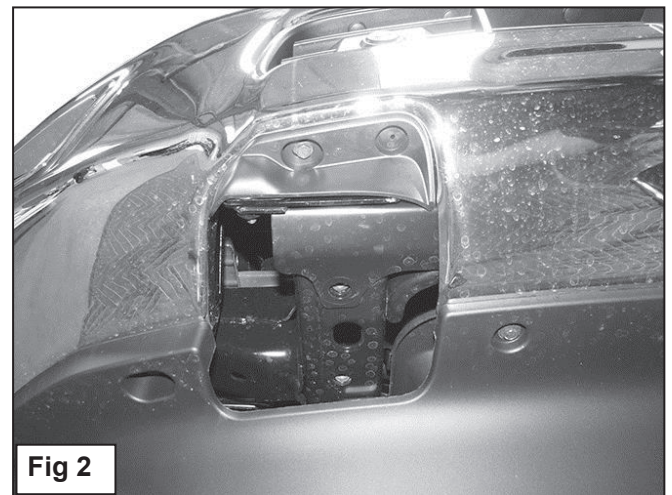
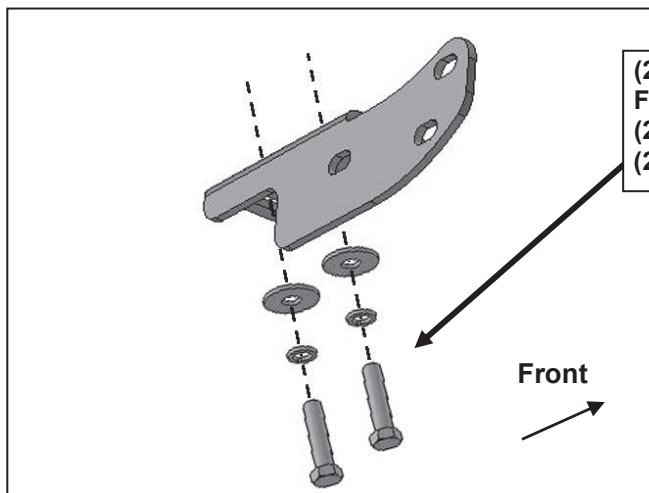

Fig 2



(Fig 3) Passenger/right Frame Bracket

(2) 12-1.25mm x 55mm
Fine Thread Hex Bolts
(2) 12mm Lock Washers
(2) 12mm Flat Washers

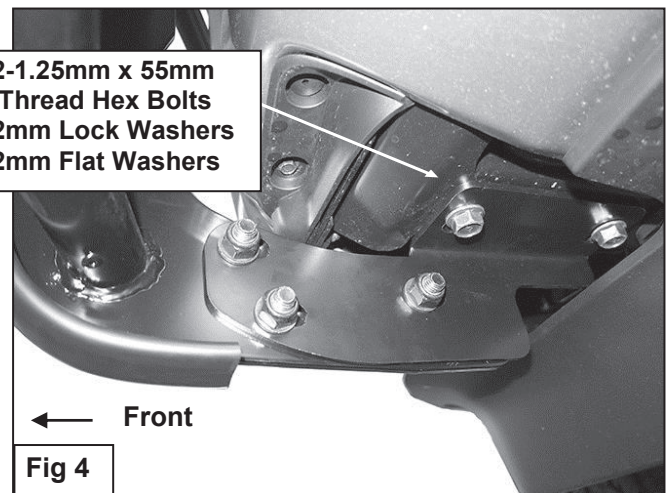
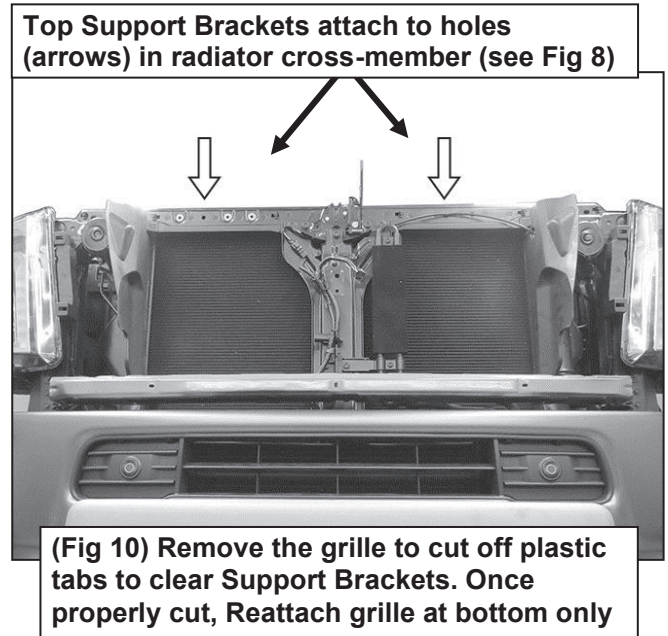
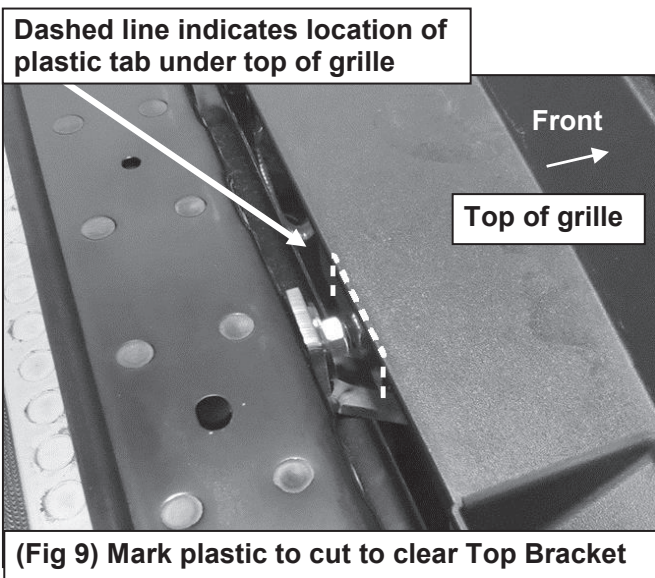
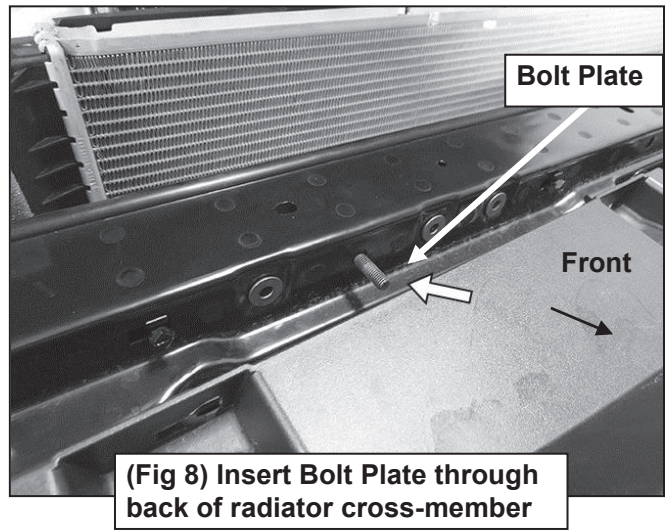
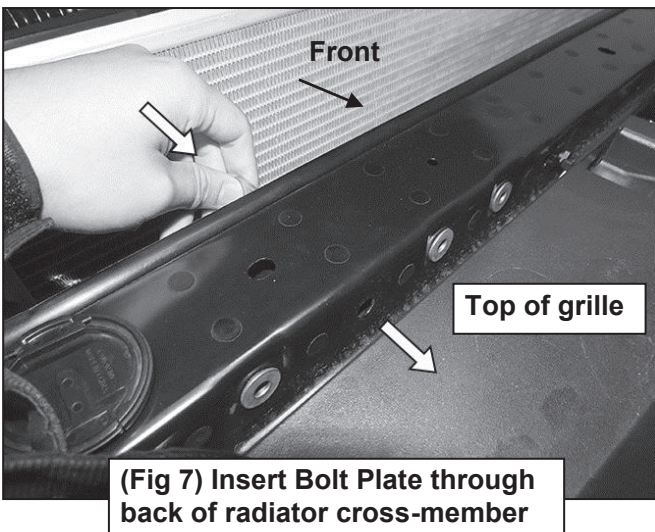
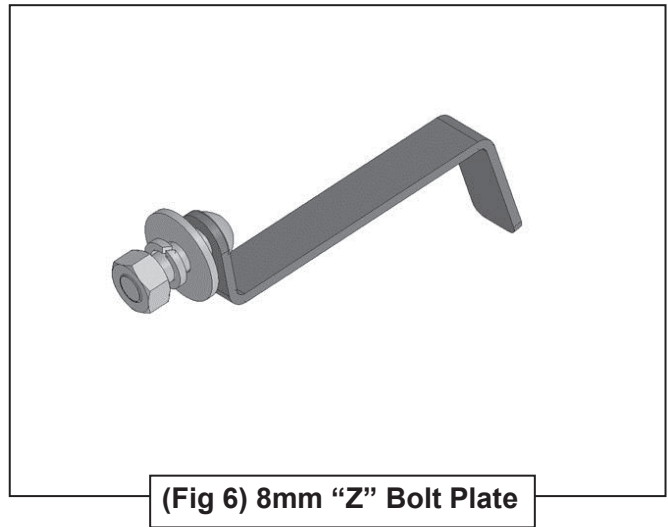
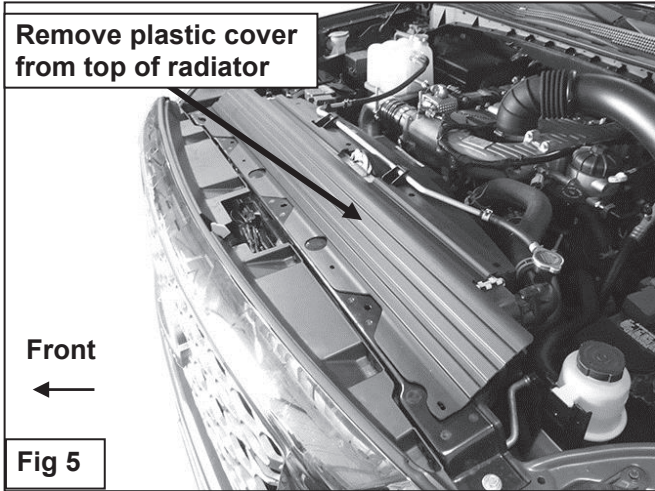
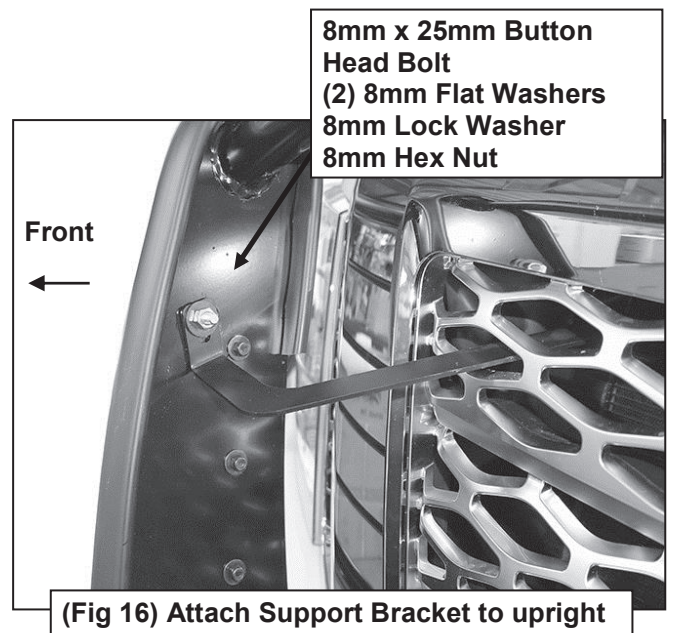
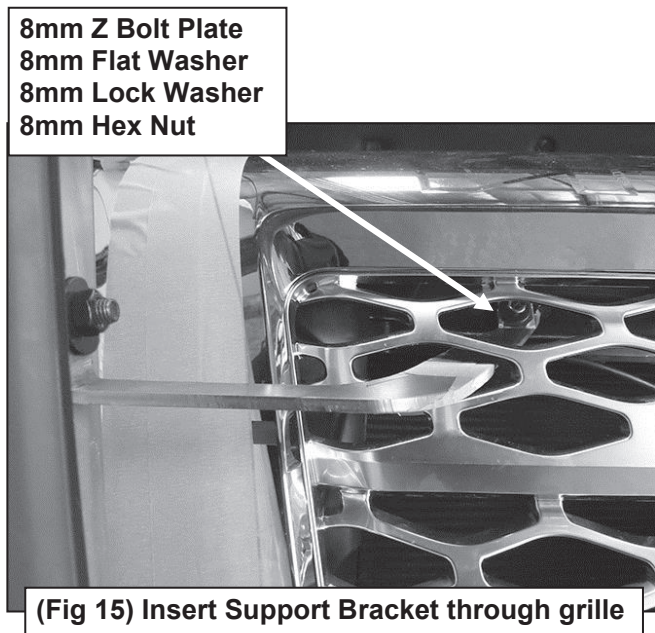
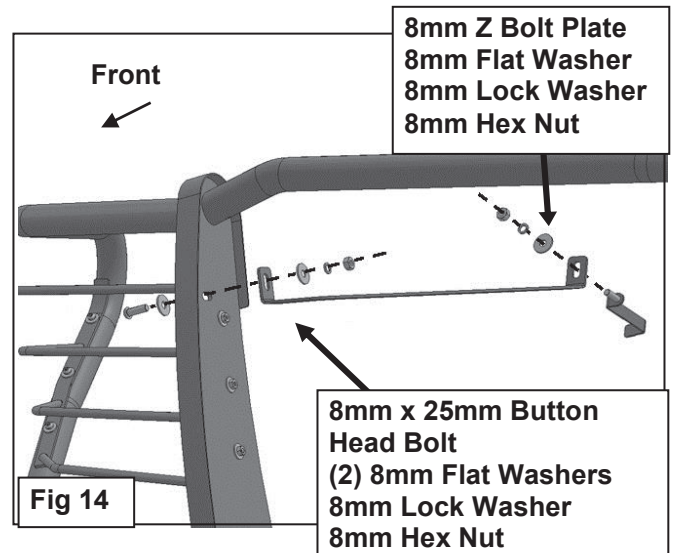
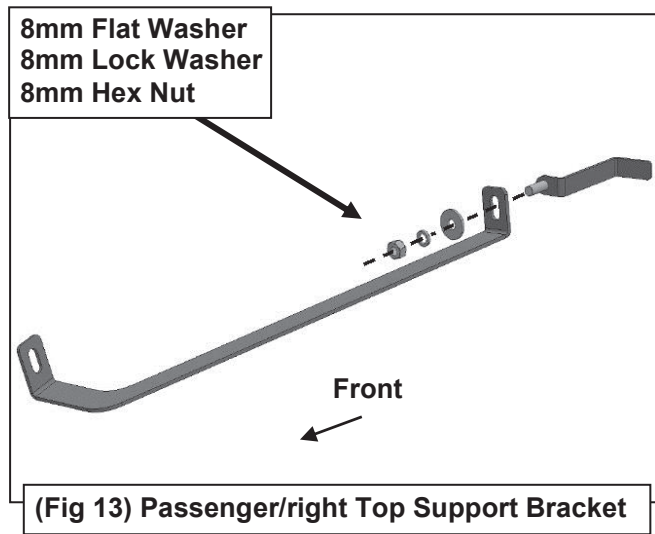
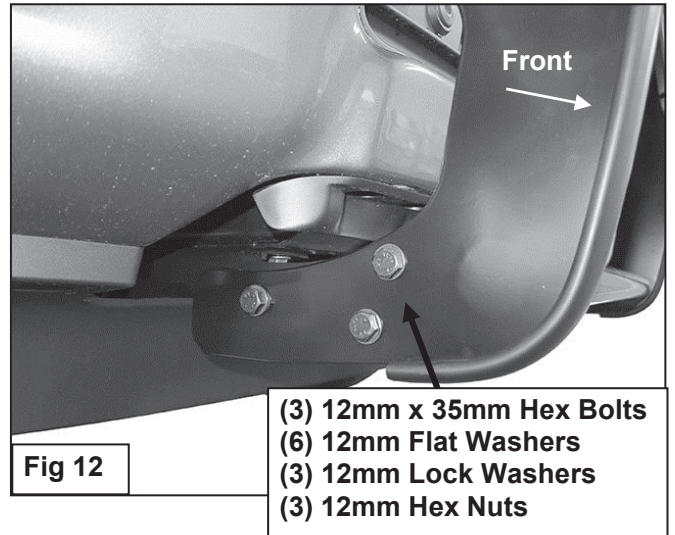
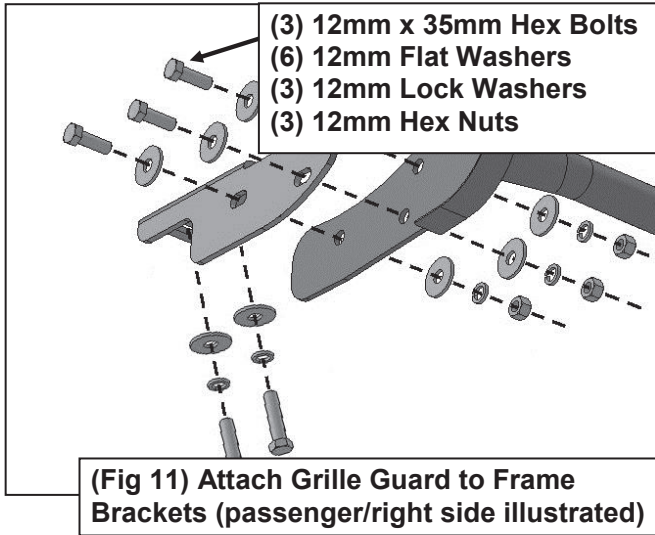

Fig 4

Passenger/right side installation pictured



Passenger/right side installation pictured



Passenger/right side installation pictured



Installation Complete