

### Parts List

1	Grille guard assembly
2	Frame bracket
1	Driver / left mounting bracket
1	Passenger / right mounting bracket
1	Driver / left top bracket, 2014 - 2015
1	Passenger / right, top bracket, 2014 - 2015
1	Driver / left top bracket, 2016 - 2017
1	Passenger / right, top bracket, 2016 - 2017
2	Clip nut, M8
6	Hex bolt, M8 - 1.25mm x 30mm
6	Flat washer, M8 x 16mm OD x 1.6mm
6	Lock washer, M8
6	Hex bolt, M10 - 1.50mm x 30mm
12	Flat washer, M10 x 27mm OD x 3mm
6	Lock washer, M10
6	Hex nut, M10 - 1.50mm
2	Double bolt plate, M12 - 1.75mm x 30mm
2	Single bolt plate, M12 - 1.75mm x 35mm
6	Flat washer, M12 x 24mm OD x 2.5mm
6	Lock washer, M12
6	Hex nut, M12 - 1.75mm

### Tools Required

Ratchet	Wrench, 19mm
Socket, 10mm	Socket, 13mm
Socket, 17mm	Socket, 19mm
Allen Wrench, 6mm	

### Level of Difficulty

Easy



Scan for helpful install tips

### Product Image



### Brackets and Hardware

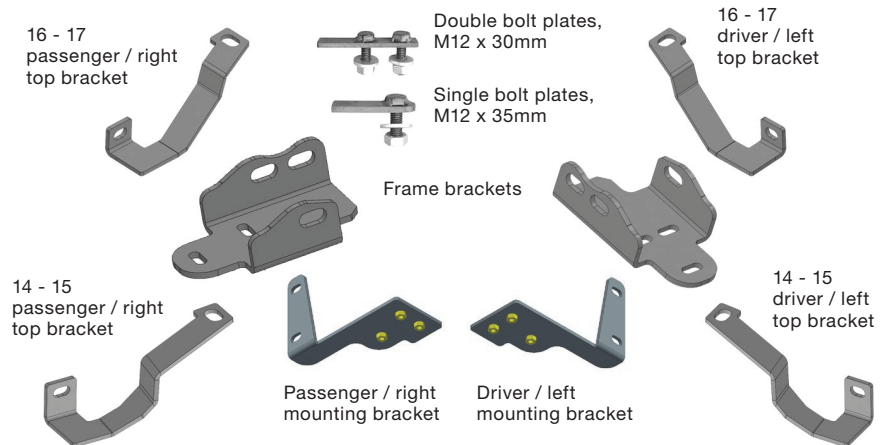

## Torque Specifications

METRIC	M6 bolt	3 ft.-lbs.
	M8 bolt	7 ft.-lbs.
	M10 bolt	16 ft.-lbs.
	M12 bolt	28 ft.-lbs.
SAE	1/4" bolt	3 ft.-lbs.
	5/16" bolt	7 ft.-lbs.
	3/8" bolt	16 ft.-lbs.
	7/16" bolt	20 ft.-lbs.
1/2" bolt	28 ft.-lbs.	

Use above torque setting unless otherwise noted

## Notes and Maintenance

Before you begin installation, read all instructions thoroughly.

Proper tools will improve the quality of installation and reduce the time required.

To protect the product, wax after installing. Regular waxing is recommended to add a protective layer over the finish. Do not use any type of polish or wax that may contain abrasives that could damage the finish.

For polished, gloss and other smooth finishes, polish may be used to clear small scratches and scuffs on the finish.

Mild automotive detergent may be used to clean the product. Do not use dish detergent, abrasive cleaners, abrasive pads, wire brushes or other similar products that may damage the finish.

Refer to the table to the left when securing hardware during the installation process to help prevent damage to the product or vehicle.

### Step 1

Select an LED light, mounting hardware and a set of brackets (sold separately). Attach the hardware to the support flange.

**Note:** The LED manufacturers may have different mounting styles or brackets. Once the mounting option is determined, attach it to the support flange.

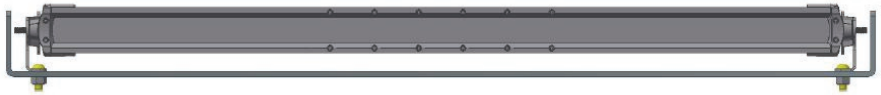

### Step 2

With the LED light attached to the support flange, place a clip nut on both ends of the support flange.

Insert an M8 hex bolt, lock washer and flat washer into the clip nut. Leave enough space between the flat washer and clip nut to slot the support flange into the light bar cage on the grille guard.

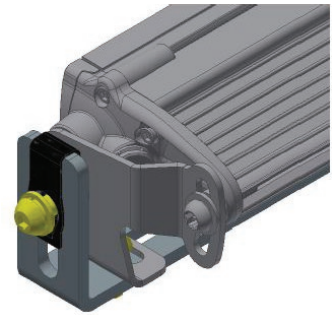
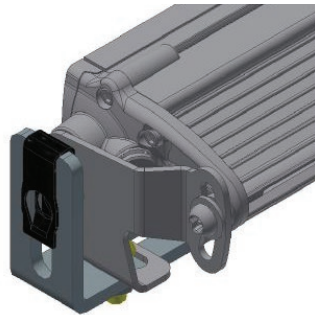

### Step 3

Place the grille guard face down on a flat, stable work surface.

Insert the support flange into the light bar cage on the grille guard and ensure the flat washer, lock washer and head of the hex bolt are on the outside of the center flange.

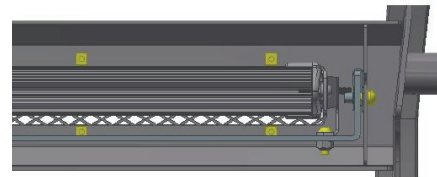
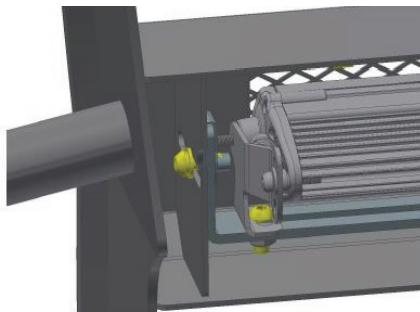

#### Step 4

Open the hood and remove the cover between the top of the radiator and the grille. Remove the hardware attaching the grille at the top and bottom.



#### Step 5

On the 2014 - 15 models, from behind the bumper, release the clips and hardware to remove the plastic body panel (fascia). Release the clips and hardware on top of the bumper, between the bottom of the grille and the top of the bumper.

For all models, carefully remove the grille from the vehicle.

The grille is held in place with screws at the top and with several clips. Remove the screws and firmly pull the grille straight out from the vehicle to release the grille from the clips.

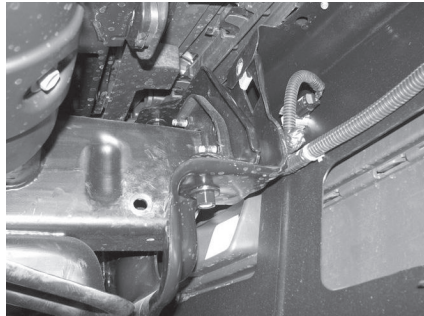

On the 2014 - 15 models, from behind the bumper, remove the clips securing the fascia to the top of the bumper.

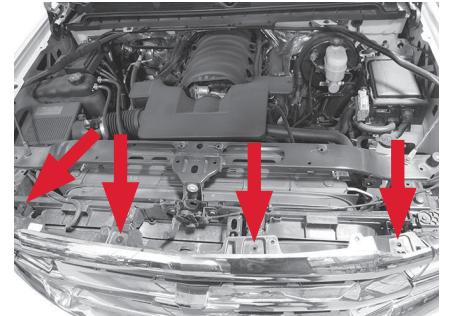

Remove the cover between the radiator and the grille. Remove the screws attaching the top of the grille (arrows).

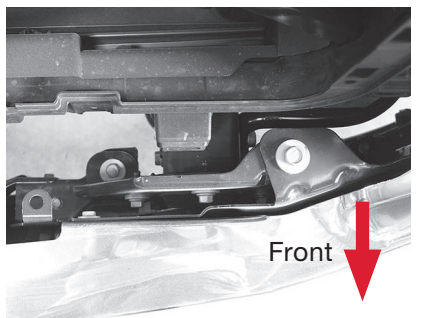
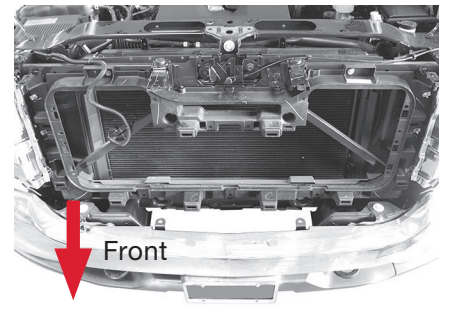
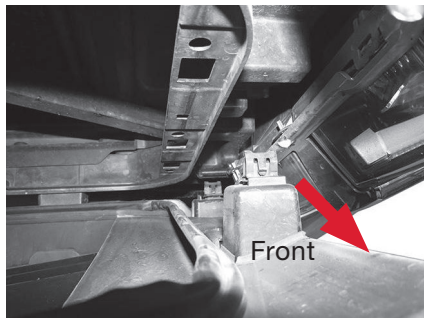

## Step 6

Depending on the year of the vehicle, select either the 2014 - 15 driver / left top bracket or the 2016 - 17 driver / left top bracket.

**IMPORTANT:** To prevent the top brackets from damaging the finish on the vehicle during installation, cover the top of the bumper with masking tape. Re-use the bumper bolt hardware to bolt the top bracket to the upper bumper. Leave the hardware loose at this time.

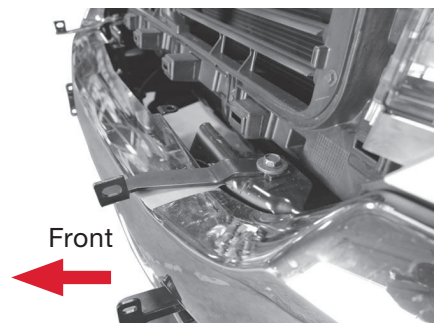
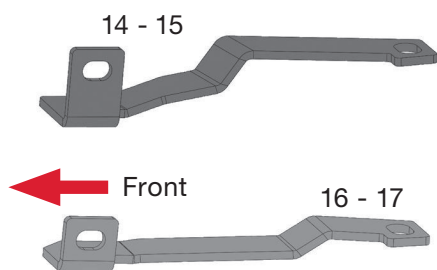

## Step 7A (With factory tow hooks)

Remove the factory tow hooks and hardware if equipped.

**IMPORTANT:** The tow hooks cannot be reinstalled with the grille guard. It is not necessary to remove the bumper. Loosen the hardware enough to rotate the bumper to remove the long hex bolts from the tow hooks.

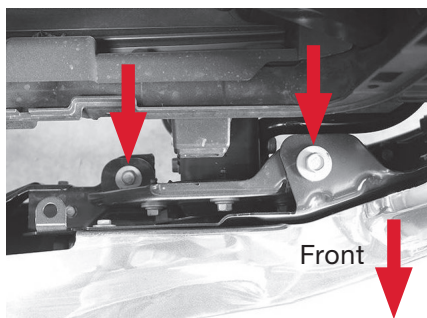

## Step 7B (Without factory tow hooks)

Cut out the indented area on both sides of the plastic bumper insert to clear the brackets as pictured.

**IMPORTANT:** Make several small cuts for the best fit. Do not cut through the top edge of the panel.

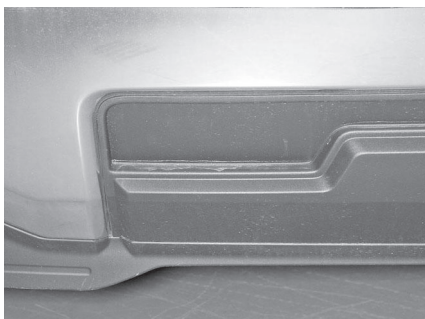

### Step 8

Locate the driver side frame bracket. Insert the frame bracket through the opening in the bumper. Line up the holes on the bracket with the holes on the end of the frame for the tow hook.

Insert one M12 double bolt plate into the end of the frame, through the two holes in the side of the frame and out through the frame bracket. Secure the frame bracket to the bolt plate with two M12 flat washers and two M12 lock washers and two M12 hex nuts.

Snug the hardware, but do not fully tighten.

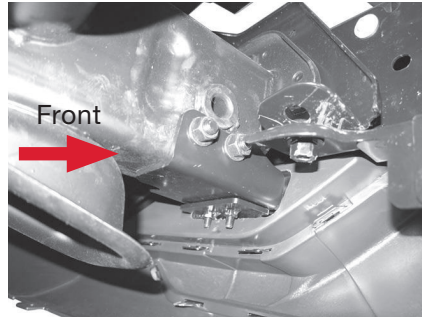
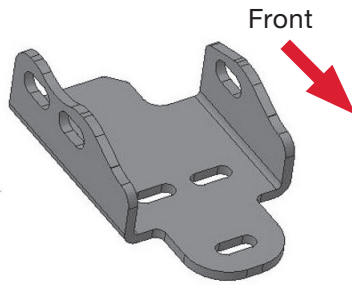

### Step 9

Locate one M12 single bolt plate. Secure the frame bracket to the bolt plate with an M12 flat washer, lock washer and hex nut.

Snug the hardware, but do not fully tighten.



### Step 10

Take the driver side mounting bracket and bolt it to the bottom of the frame bracket with three M8 x 30mm hex bolts, three M8 lock washers and three M8 flat washers.

Snug the hardware, but do not fully tighten.



### Step 11

Repeat steps 4 through 10 to install the passenger-side brackets.



### Step 12

With assistance, hold the grille guard up in position on the outside of the mounting brackets. Bolt the grille guard to the brackets with six M10 hex bolts, (12) M10 flat washers, six M10 lock washers and six M10 hex nuts.

Snug the hardware, but do not fully tighten.



### Step 13

Check the grille guard alignment with the vehicle. Adjust as required and tighten frame bracket hardware.

Level and adjust the grille guard and fully tighten all of the hardware.

Reinstall the grille and the top plastic cover.



### Step 15

Congratulations on the installation of your new ARIES Pro Series™ grill guard.

With the grill guard installed, periodic inspections should be performed to ensure all mounting hardware remains tight.

To protect your investment, see the 'Notes and Maintenance' section on the second page of this instruction manual.

