

INSTALLATION MANUAL

3069

Level of Difficulty

Easy

Parts List

1	Grille guard
1	Driver / left frame bracket
1	Passenger / right frame bracket
1	Driver / left top bracket
1	Passenger / right top bracket
4	Hex bolt, 12-1.75mm x 45mm
4	Large flat washer, 2mm x 44mm x 4mm
4	Lock washer, 12 mm
4	Hex bolt, 10-1.5mm x 35mm
8	Flat washer, 10mm x 27mm OD x 3mm
4	Nylon lock nut, 10-1.5mm
2	Hex bolt, 8-1.25mm x 25mm
4	Flat washer, 8mm x 16mm x 1.6mm
2	Nylon lock nut, 8mm

Tools Required

Socket set	Cutting tool
Box wrench	--

Torque Specifications*

Metric	6 mm bolt	3 ft.-lbs.
	8mm bolt	7 ft.-lbs.
	10mm bolt	16 ft.-lbs.
	12mm bolt	28 ft.-lbs.

Use above torque setting unless otherwise noted

Product Registration and Warranty

CURT Group stands behind our products with industry-leading warranties. Provide feedback and help us to improve our products by registering your purchase at: warranty.curtgroup.com/surveys

Product Photo



Brackets and Hardware

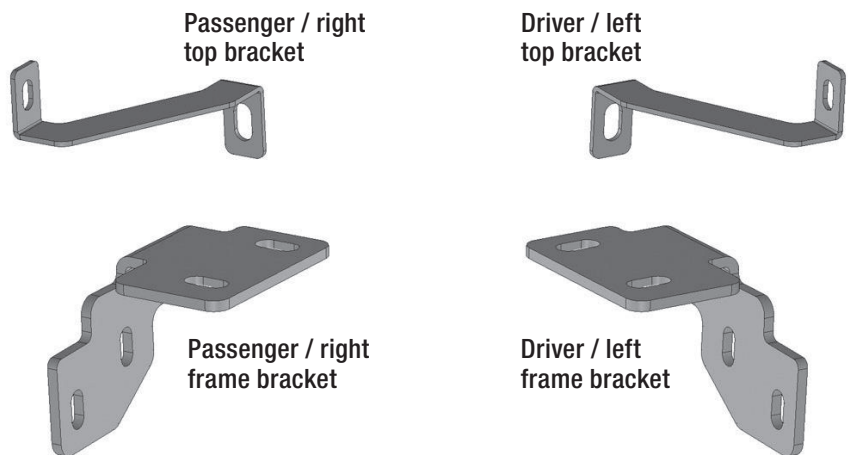

NOTICE

Before you begin installation, read all instructions thoroughly.

Proper tools will improve the quality of installation and reduce the time required.

To help prevent damage to the product or vehicle, refer to the specified torque specifications when securing hardware during the installation process.

Maintenance

To protect the product, wax after installing. Regular waxing is recommended to add a protective layer over the finish. Do not use any type of polish or wax that may contain abrasives that could damage the finish.

For polished, gloss and other smooth finishes, polish may be used to clear small scratches and scuffs on the finish.

Mild automotive detergent may be used to clean the product. Do not use dish detergent, abrasive cleaners, abrasive pads, wire brushes or other similar products that may damage the finish.

PROCEDURE:

REMOVE CONTENTS FROM BOX AND VERIFY ALL PARTS ARE PRESENT. READ INSTRUCTIONS CAREFULLY. CUTTING MAY BE REQUIRED. ASSISTANCE IS RECOMMENDED. INSTALLATION MAY INTERFERE WITH FRONT MOUNTED SENSORS.

1. Start installation from under the front of the vehicle.
2. Determine if the vehicle is equipped with tow hooks, **(Figure 1)**.

Tow Hook equipped vehicles:

- a. Remove the plastic cover attached to the tow hook, **(Figure 1)**. Next, remove the tow hook from the bottom of the frame, **(Figures 2—4)**. On models with steel skid plate, temporarily remove skid plate, **(Figure 3)**.
- b. Proceed to **Step 3**.

Vehicles without tow hooks:

- a. Cut out the lower section of the indented area in both sides of the plastic bumper to clear the Brackets as pictured, **(Figure 5)**. **NOTE:** Hold the Frame Mounting Bracket up to the back of the bumper to determine area to remove to clear Bracket. **IMPORTANT:** Make several small cuts for best fit.
- b. Insert the Mounting Brackets through the openings in the bumper to check for clearance around Brackets and hardware. Trim the plastic as required to clear the Brackets.
3. Select the driver/left Frame Mounting Bracket, **(Figure 6)**. Hold the Bracket up to the bottom of the frame. Line up the holes in the Bracket with the (2) mounting bolt holes for the tow hook.

Models without tow hooks:

- a. Attach the Bracket to the threaded holes in the frame with (2) 12mm x 45mm Hex Bolts, (2) 12mm Lock Washers and (2) 12mm Flat Washers, **(Figures 6 & 7)**.
- b. Repeat to attach the passenger/right Frame Bracket.

Models with tow hooks:

- a. Install the Bracket between the tow hook and the bottom of the frame, **(Figure 7)**.
- b. Attach the Bracket and tow hook to the threaded holes in the frame with (2) 12mm x 45mm Hex Bolts, (2) 12mm Lock Washers and (2) 12mm Flat Washers, **(Figures 6 & 7)**. Leave hardware loose.
- c. Repeat previous **Steps** to attach the passenger/right Frame Bracket and tow hook.
4. Next, from behind/below the driver/left side of the front bumper, locate and remove the top bumper bracket bolt, **(Figures 8 & 9)**. Apply removable tape (masking tape for example) to the top of the bumper in line with the factory bumper bolt, **(Figures 10 & 12)**.
5. Select the driver/left Top Bracket, **(Figures 10 & 11)**. Carefully slide the inner end of the Bracket through the gap between the lower bumper and upper plastic fascia panel. Reuse the factory bumper bolt to attach the Top Bracket to the back of the bumper bracket, **(Figure 12)**.
6. Repeat **Steps 4 & 5** to install the passenger/right Top Bracket.
7. With assistance, hold the Grille Guard up in position on the outside of the Mounting Brackets. Attach the Grille Guard to the Frame Mounting Brackets with the included (4) 10mm x 35mm Hex Bolts, (8) 10mm Flat Washers and (4) 10mm Nylon Lock Nuts, **(Figures 13 & 14)**. Do not tighten hardware at this time.
8. Attach the Grille Guard to the Top Brackets with (2) 8mm x 25mm Hex Bolts, (4) 8mm Flat Washers and (2) 8mm Nylon Lock Nuts, **(Figure 15)**.
9. Check the Grille Guard for alignment with the vehicle and for clearance between the Grille Guard and the bumper. Adjust as required then fully tighten all hardware.
10. Do periodic inspections to the installation to make sure that all hardware is secure and tight.

Driver/left Side Installation Pictured



(Fig 1) Example of Tow hook

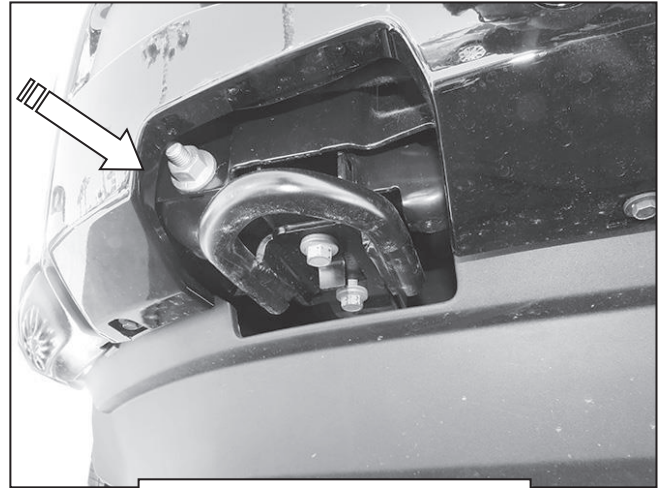

(Fig 2) Remove plastic cover surrounding tow hook

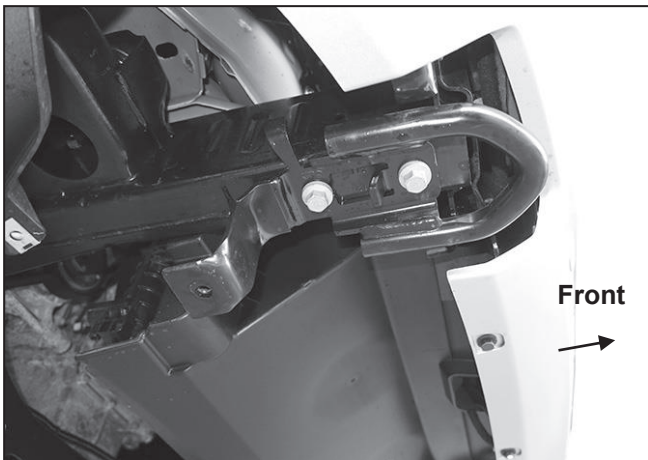

(Fig 3) Models with steel skid plate, temporarily remove skid plate to access tow hooks

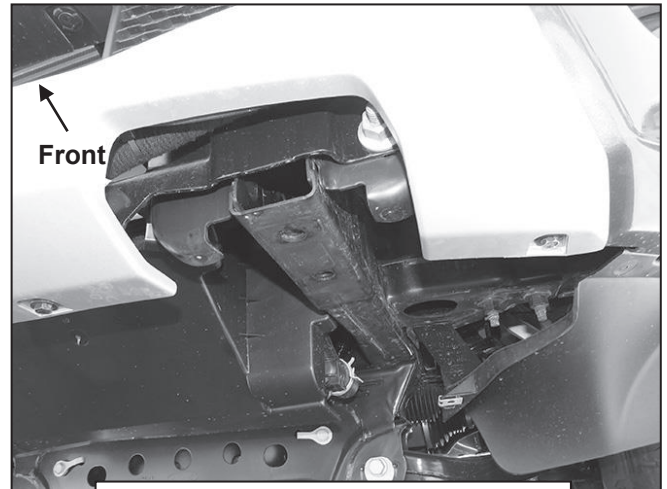

(Fig 4) Driver/left mounting location



(Fig 5) Models without tow hooks, cut openings in lower plastic cover to clear Brackets

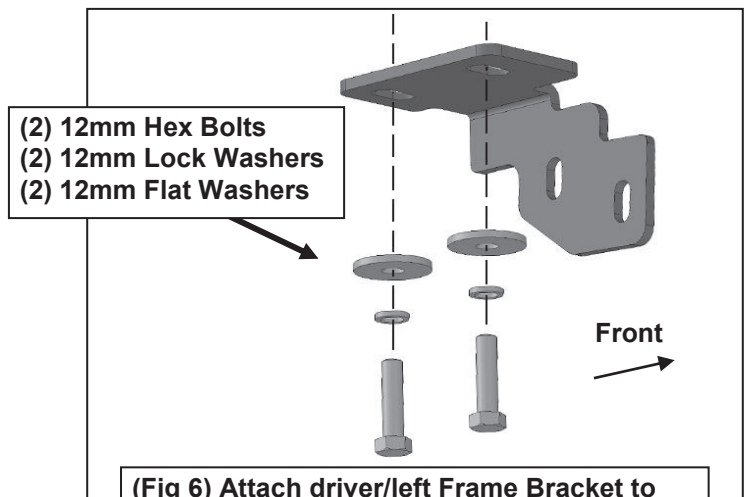

(Fig 6) Attach driver/left Frame Bracket to bottom of frame. Models with tow hooks, install Bracket between tow hook and frame

Driver/left Side Installation Pictured

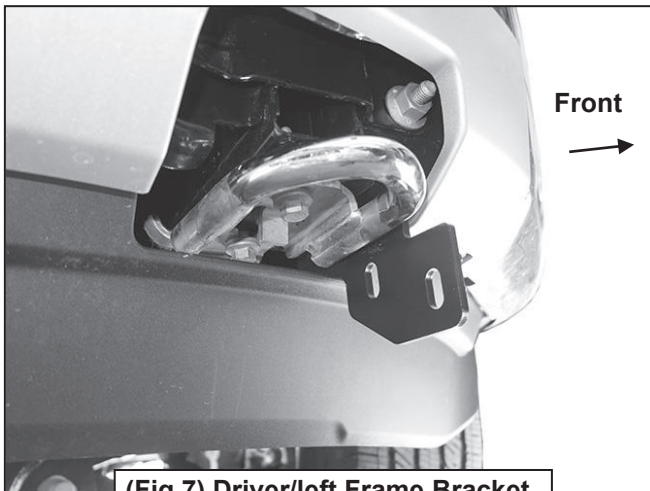

(Fig 7) Driver/left Frame Bracket installed with tow hook

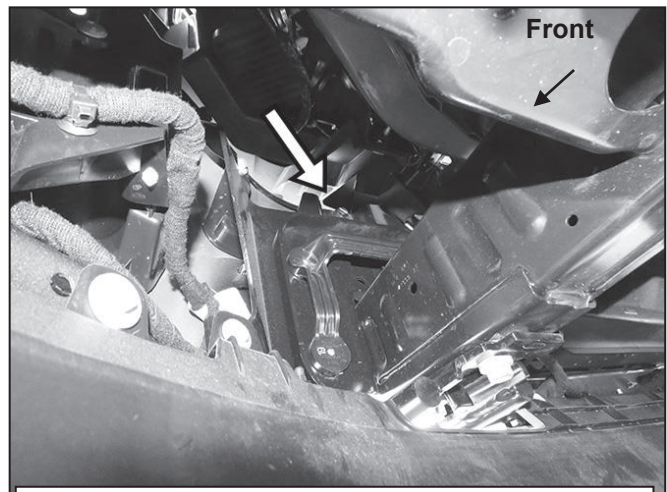

(Fig 8) Remove top bumper bracket bolt (arrow). Driver/left side pictured from below and behind bumper (also see Fig 9)

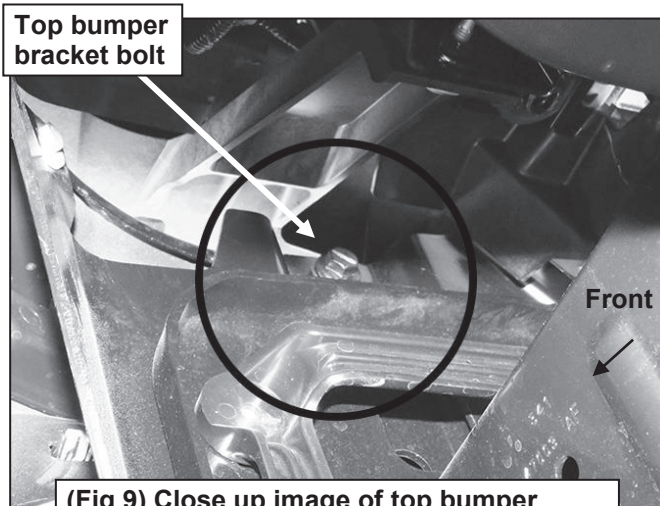

(Fig 9) Close up image of top bumper bracket bolt. Driver/left side pictured from below and behind bumper (also see Fig 8)

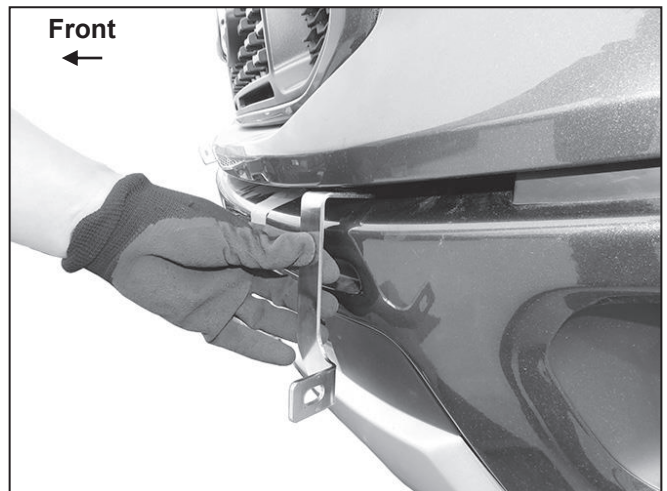

(Fig 10) Carefully insert bent end of driver/left Top Bracket through gap between lower bumper and upper plastic fascia panel. Use removable tape to protect finish on bumper

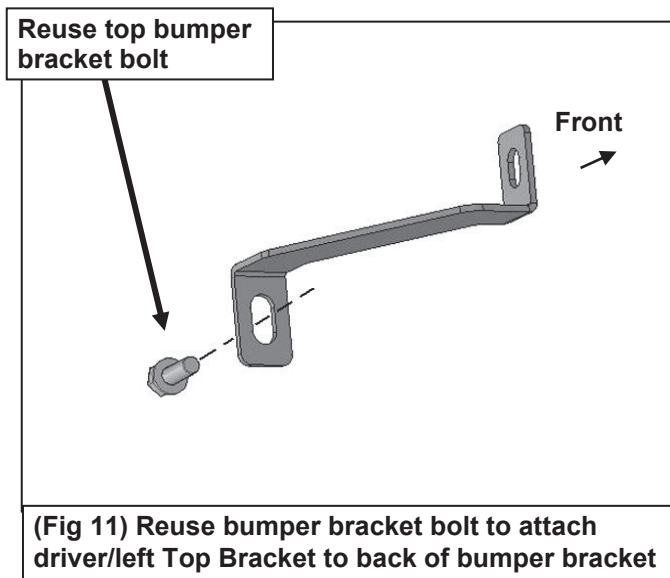

(Fig 11) Reuse bumper bracket bolt to attach driver/left Top Bracket to back of bumper bracket

Driver/left Side Installation Pictured



(Fig 12) Top Brackets installed

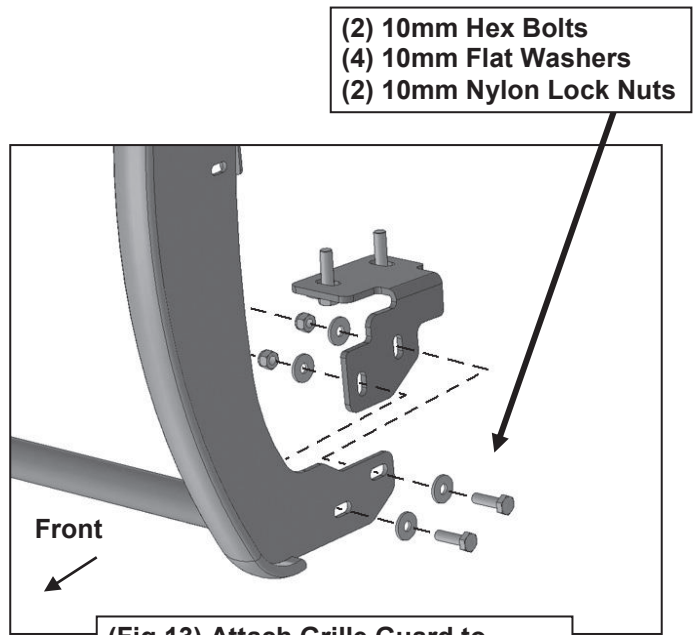

(Fig 13) Attach Grille Guard to outside of driver/left Frame Bracket

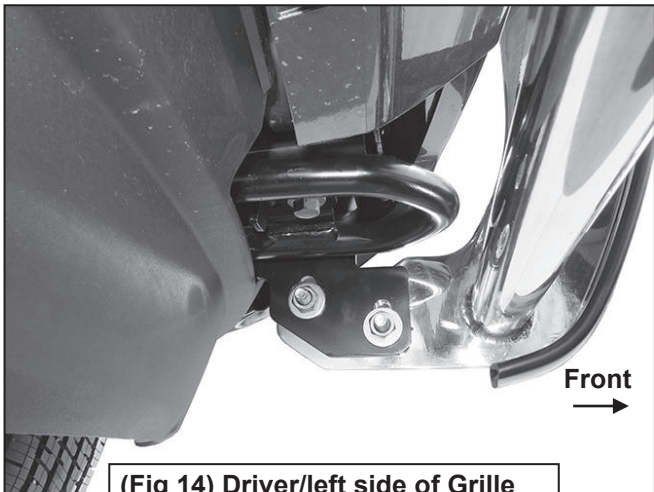

(Fig 14) Driver/left side of Grille Guard attached to Frame Bracket

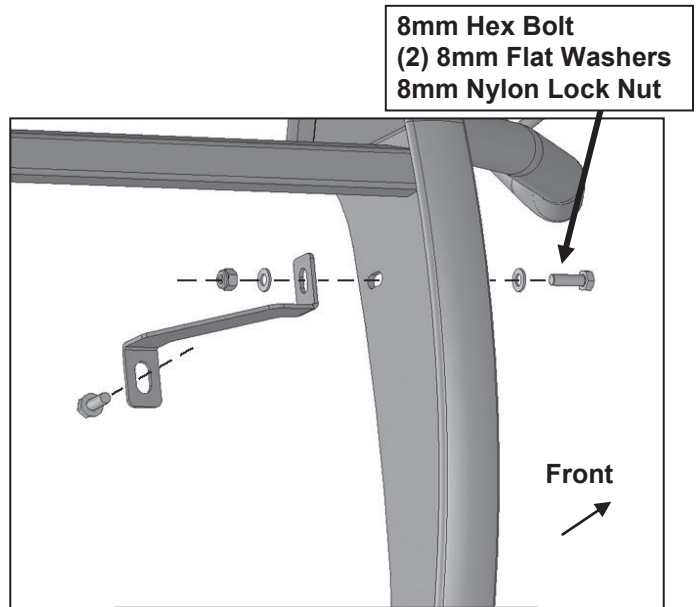

(Fig 15) Driver/left side of Grille Guard attached to Top Bracket

